



DIAPHRAGM PUMPS

SLL series	8
EL-N series	9
EL-S series single system	10
EL-S series twin system	11
OEM assembly pumps	12
Phoe-niX series	14

Applications

Water treatment and environmental technology

- Domestic sewage plants
- Grease trapping
- Air ventilation of waste water
- Biogas production

Aquacultur

- Aeration of Koi and garden ponds
- Filter systems
- Aeration of chemical and biological bath

Medical and health technology

- Scent systems and odor neutralisation
- Tank pressuration
- Airbeds and decubitus mattresses
- Underwater massages and whirlpools
- Compression therapy
- Inhalation devices and nebulizer

Aeration of fuel cell stacks

Aqua-air-lights and design pillars

Advantages

- Long life expectancy
- Low power consumption
- High degree of efficiency
- Low vibration
- Low noise
- Oil-free operation
- Constant air flow
- Simple maintenance

DIAPHRAGM PUMPS

Examples of use

Blowers and vacuum pumps are ideally suited for applications where minimum energy consumption, delivery of absolutely oil-free air, near silent operation and a minimum of simple maintenance are either prerequisites or of great advantage.

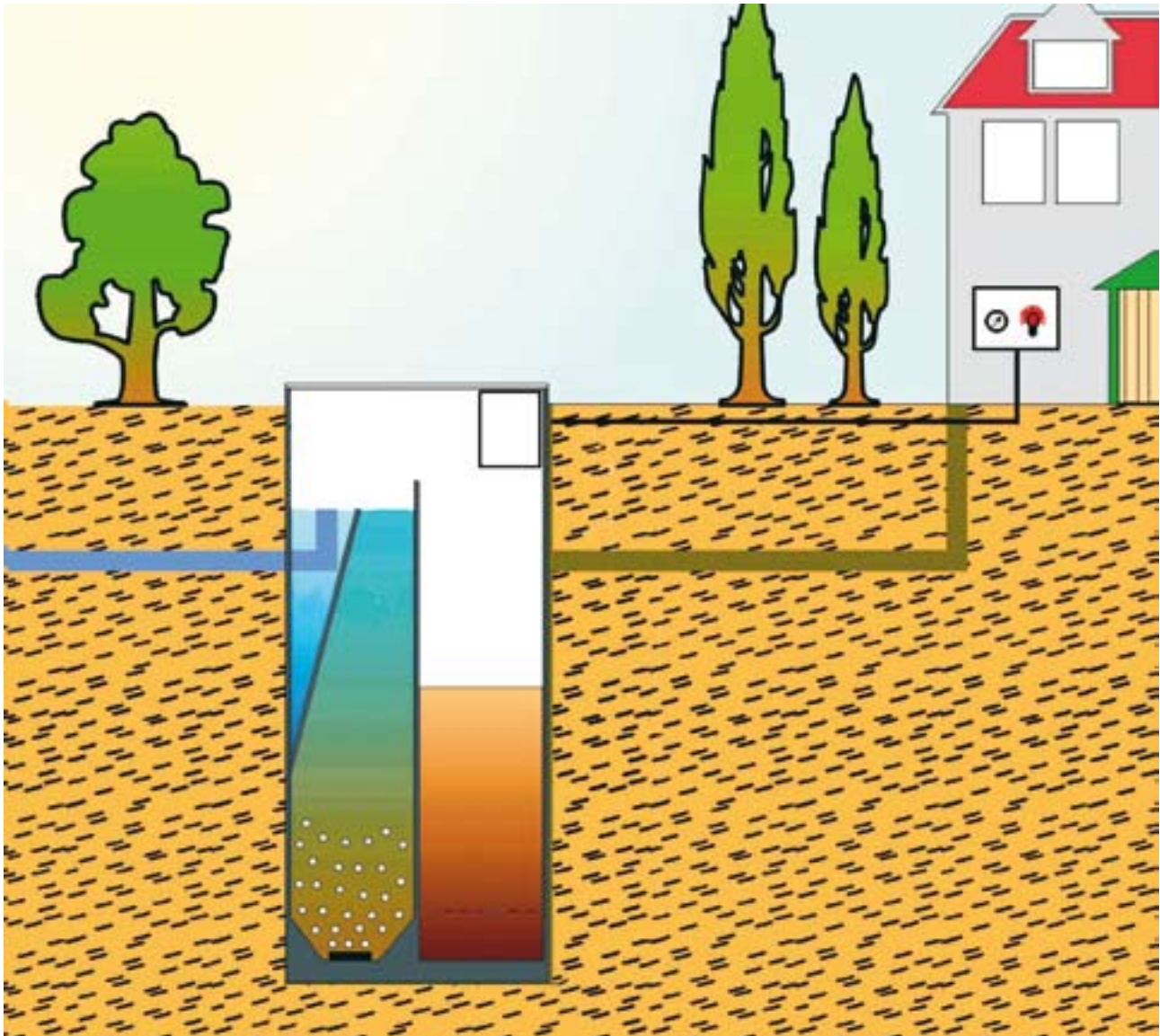

DIAPHRAGM PUMPS

Operating principle

The activated electromagnets put a permanent magnet into oscillation movements. The magnet holder moves now at the same frequency as that of the power supply - normally 50 Hz respectively 60 Hz - back and forth between the electromagnets and sets a diaphragm going on both sides, which then changes the valve box volume. By discharging via the valves, both pressure and vacuum can be realized.

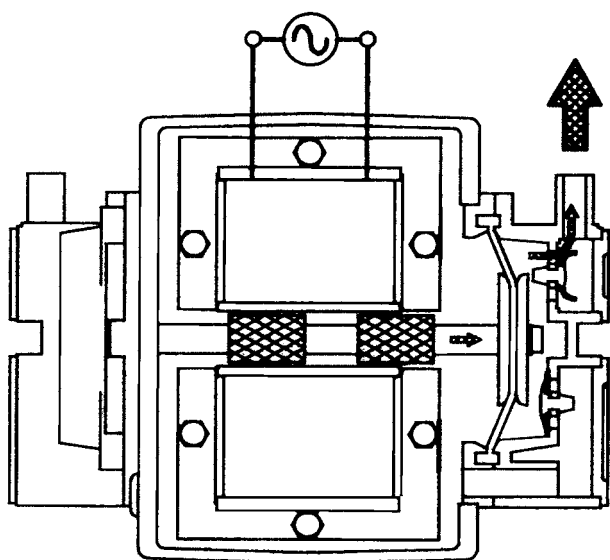

Choose the right pump capacity

The technical specifications from different diaphragm pump manufacturers are based on various reference pressure levels. We therefore recommend that you compare the performance data of the diaphragm pumps exactly.

We are happy to advise you so that you find the correct model for your application.

Your advantages

Long life expectancy

Motor and pump parts are combined in one single construction. The compact and light construction form and the simple mechanism guarantee a long and reliable period of operation.

High degree of efficiency

The principle of electromagnetic oscillation, which practically has no mechanical friction, minimises power consumption and provides a high degree of efficiency.

Low noise level

The soundproof casing and the muffler integrated in the tank base reduce operating noise.

Low vibration

Motor and pump parts are separated by a vibration-isolating rubber, so only low vibration consists.

Completely oil-free

The oil-free operation guarantees a dry and unadulterated air flow.

Pulsation-free air flow

Specially formed pump chambers and the muffler integrated in the tank base provide an air flow, which is practically pulsation-free.

Weatherproof

The SLL and EL series are rainproof and weatherproof. However, they should not be exposed to direct sunlight, rain or snow.

Universal service kits

For each model series service kits are available. They are vacuum-packed in aluminium foil for better and longer life/storage.



SLL series

SLL-20 / SLL-30 / SLL-40 / SLL-50

Product characteristics

- Integrated overload protection
- Connecting hose included in delivery

Dimensions

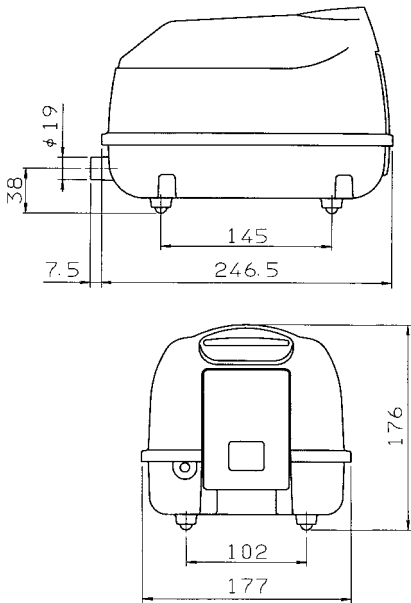

Technical data

Model			SLL-20	SLL-30	SLL-40	SLL-50
Air flow ¹⁾	l/min	0 mbar	52	60	68	75
		50 mbar	44	52	60	68
		100 mbar	36	43	53	61
		150 mbar	28	34	45	53
		200 mbar	18	26	36	44
Voltage ²⁾	VAC		230	230	230	230
Power consumption	W	180 mbar	18	27	41	53
Noise level	dB(A)		30	32	33	37
Dimensions	mm	L x W x H	254 x 177 x 176			
Connection	mm	Ø outside	19	19	19	19
Net weight	kg		4.5	4.5	4.5	4.5

¹⁾ Product performance may vary +/- 10% from performance curves

²⁾ Values at 50 Hz

Performance data

Optimal operating span

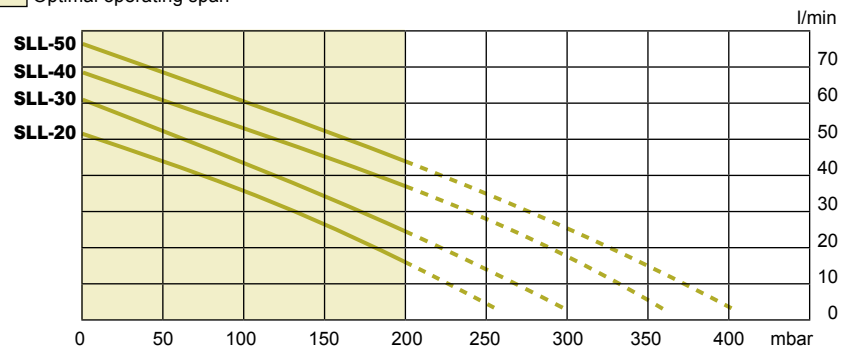



EL-N series

EL-S-60N

Product characteristics

- Integrated overload protection
- Protective switch inclusive
- High quality plastic housing
- Compact design
- Optional with fault alarm lamp and integrated signal cable
- Connecting hose included in delivery

Dimensions

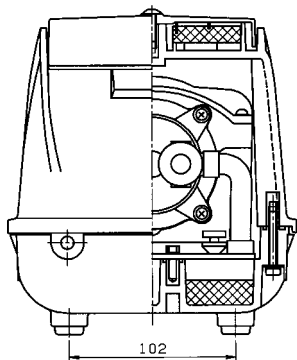
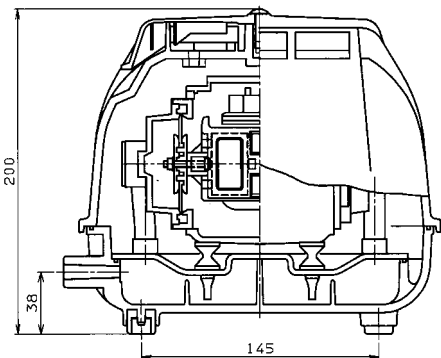

Technical data

Model			EL-S-60N
Air flow ¹⁾	l/min	0 mbar	98
		50 mbar	88
		100 mbar	76
		150 mbar	64
		200 mbar	52
		250 mbar	40
Voltage ²⁾	VAC		230
Power consumption	W	200 mbar	48
Noise level	dB(A)		43
Dimensions	mm	L x W x H	221 x 177 x 200
Connection	mm	Ø outside	19
Net weight	kg		4.4

¹⁾ Product performance may vary +/- 10% from performance curves

²⁾ Values at 50 Hz

Performance data

Optimal operating span

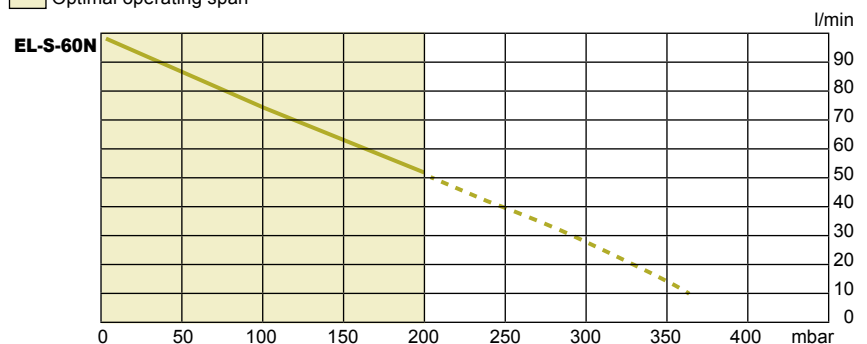



EL-S single system

EL-S-60 / EL-S-80-15 / EL-S-80-17
EL-S-100 / EL-S-120 / EL-S-150

Product characteristics

- Integrated overload protection
- Protective switch inclusive
- Optional with fault alarm lamp or integrated signal cable
- Connecting hose included in delivery

Dimensions

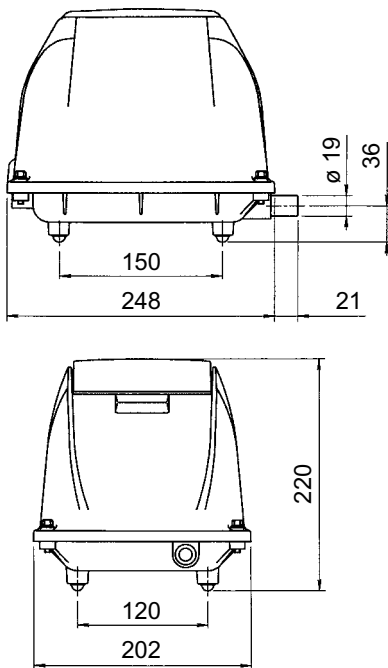

Technical data

Model			EL-S-60	EL-S-80-15	EL-S-80-17	EL-S-100	EL-S-120	EL-S-150
Air flow ¹⁾	l/min	0 mbar	105	127	142	152	190	224
		50 mbar	96	115	131	142	176	205
		100 mbar	83	102	113	130	156	182
		150 mbar	68	87	95	112	138	170
		200 mbar	54	73	77	94	123	148
		250 mbar	40	56	59	77	105	120
Voltage ²⁾	V		230	230	230	230	230	230
Power consumption	W	200 mbar	44	74	71	92	120	150
Noise level	dB(A)		36	40	40	42	55	58
Dimensions	mm	L x W x H	249 x 202 x 220					
Connection	mm	Ø outside	19	19	19	19	19	19
Net weight	kg		8.5	8.5	8.5	8.5	9	9

¹⁾ Product performance may vary +/- 10% from performance curves

²⁾ Values at 50 Hz

Performance data

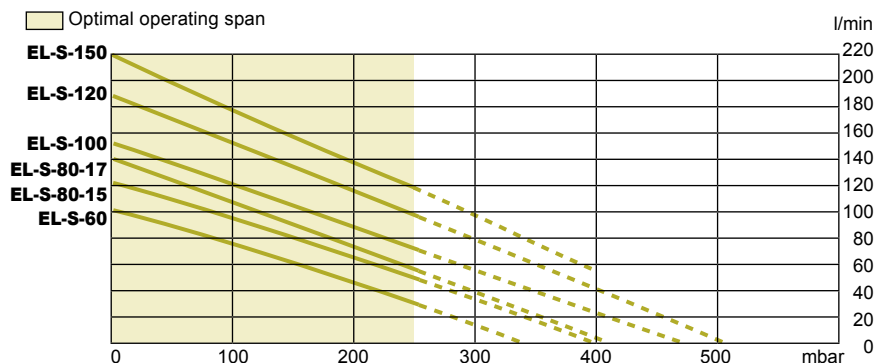



EL-S twin system

EL-S-120W / EL-S-150W
EL-S-200W / EL-S-250W

Product characteristics

- Integrated overload protection
- Protective switch inclusive
- Optional with fault alarm lamp or integrated signal cable
- Twin outlet for alternative port position

Dimensions

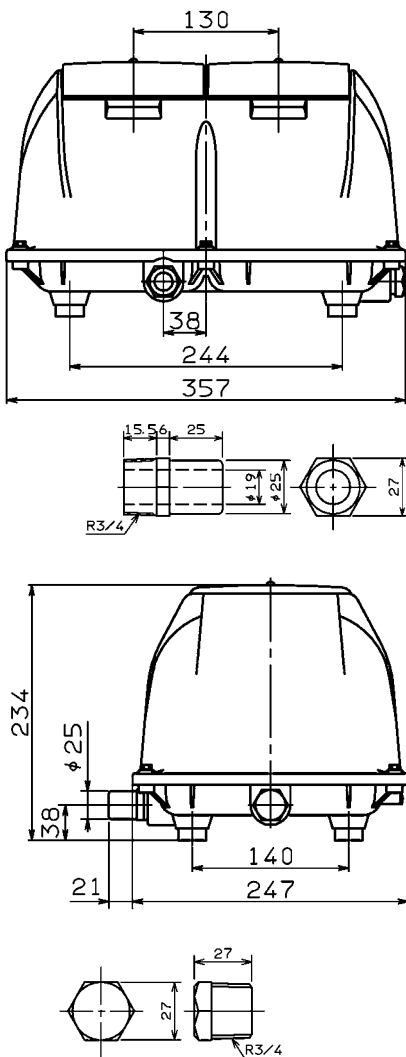

Technical data

Model			EL-S-120W	EL-S-150W	EL-S-200W	EL-S-250W
Air flow ¹⁾	l/min	0 mbar	240	290	330	360
		50 mbar	215	250	270	320
		100 mbar	185	218	250	290
		150 mbar	156	196	225	262
		200 mbar	127	165	196	233
		250 mbar	95	135	170	205
Voltage ²⁾	V		230	230	230	230
Power consumption	W	200 mbar	120	149	210	241
Noise level	dB(A)		43	44	45	55
Dimensions	mm	L x W x H	268.5 x 357 x 234			
Connection	mm	Ø outside	25	25	25	25
Net weight	kg		16	16	16	16

¹⁾ Product performance may vary +/- 10% from performance curves

²⁾ Values at 50 Hz

Performance data

Optimal operating span

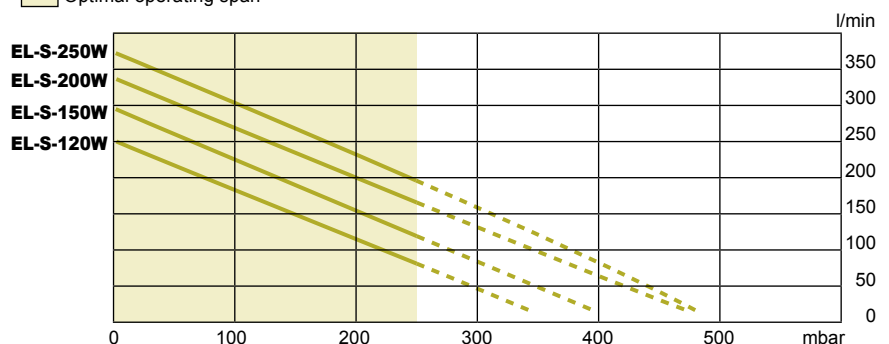



OEM assembly pump

MK-10 / MK-10-12V / MK-10-24V

Product characteristics

- Pressure and vacuum (optional) possible
- Compact design
- OEM assembly pump without overall cover

Dimensions

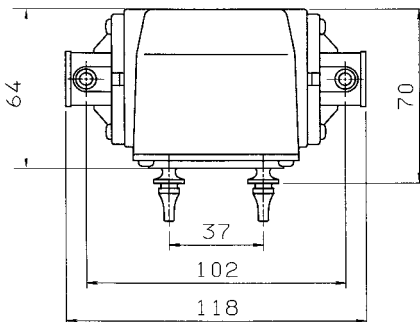
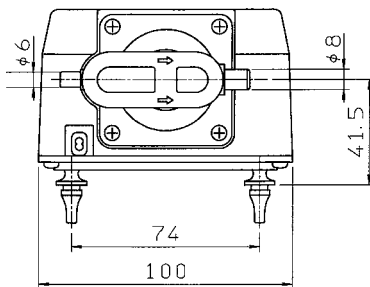

Technical data

Model		Pressure	Vacuum	MK-10	MK-10-12V	MK-10-24V
Air flow ^{1) 2)}	l/min	0 mbar	0 mbar rel	20	20	20
		50 mbar	- 50 mbar rel	15	15	15
		100 mbar	- 100 mbar rel	11	11	11
		150 mbar	- 150 mbar rel	6	6	6
Voltage ⁴⁾	V			230	12 ³⁾	24 ³⁾
Power consumption	W	100 mbar		7-8		
Noise level	dB(A)			38	38	38
Dimensions	mm	L x W x H		118 x 100 x 70		
Connection	mm	Ø outside		6/8	6/8	6/8
Net weight	kg			0.7	0.7	0.7

This model is offered in standard design only as a pressure pump. Please advise when ordering if you would like it as a vacuum version (rebuilding required).

¹⁾ Product performance may vary +/- 10% from performance curves

²⁾ The pneumatic values do not correspond for mixed operation, i. e. with both vacuum on the suction port and pressure on the outlet

³⁾ Please note: voltage of MK-10-12V and MK-10-24V is AC

⁴⁾ Values at 50 Hz

Performance data

Optimal operating span

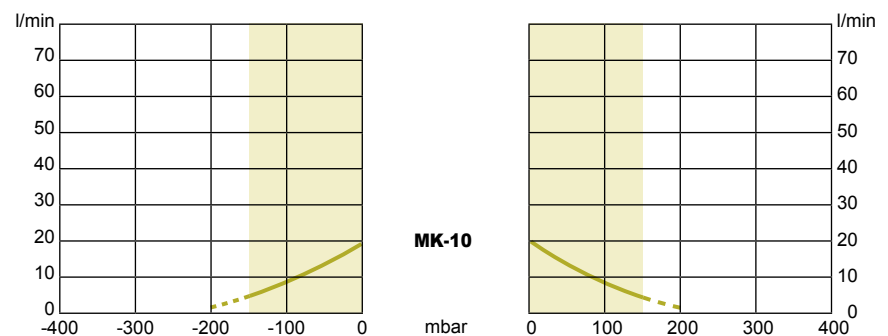



OEM assembly pump

SV-20 / SV-30 / SV-40 / SV-50

Product characteristics

- Pressure and vacuum possible
- Compact design
- OEM assembly pump without overall cover

Dimensions

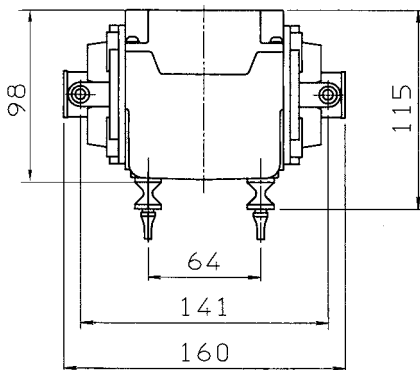
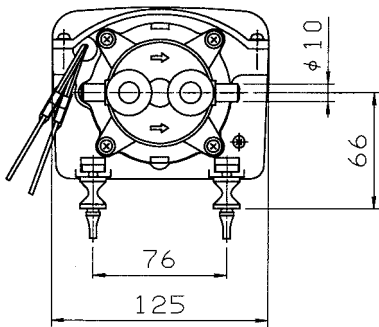

Technical data

Model		Pressure	Vacuum	SV-20	SV-30	SV-40	SV-50
Air flow ^{1) 2)}	l/min	0 mbar	0 mbar rel	50	60	68	75
		50 mbar	- 50 mbar rel	40	50	60	70
		100 mbar	- 100 mbar rel	32	40	52	60
		150 mbar	- 150 mbar rel	23	30	42	50
		200 mbar	- 200 mbar rel	15	20	32	40
Voltage ³⁾	V			230	230	230	230
Power consumption	W		180 mbar	18	27	41	53
Noise level	dB(A)			44	46	47	49
Dimensions	mm		L x W x H	160 x 125 x 115			
Connection	mm		Ø outside	10	10	10	10
Net weight	kg			2.5	2.5	2.5	2.5

¹⁾ Product performance may vary +/- 10% from performance curves

²⁾ The pneumatic values do not correspond for mixed operation, i. e. with both vacuum on the suction port and pressure on the outlet

³⁾ Values at 50 Hz

Performance data

Optimal operating span

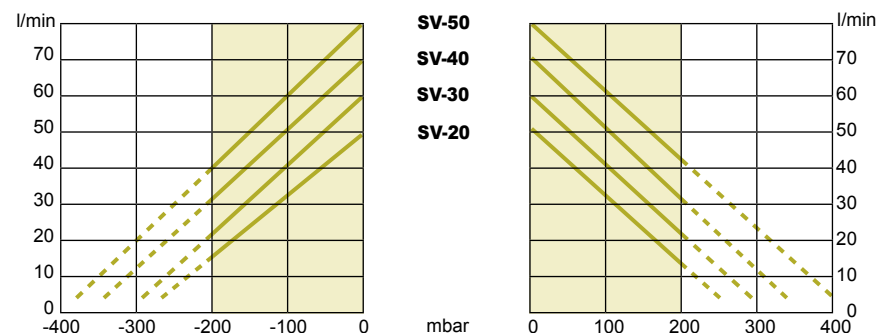



Phoe-niX series

MKC-510V

Product characteristics

- Connecting hose and air distributor included in delivery

Dimensions

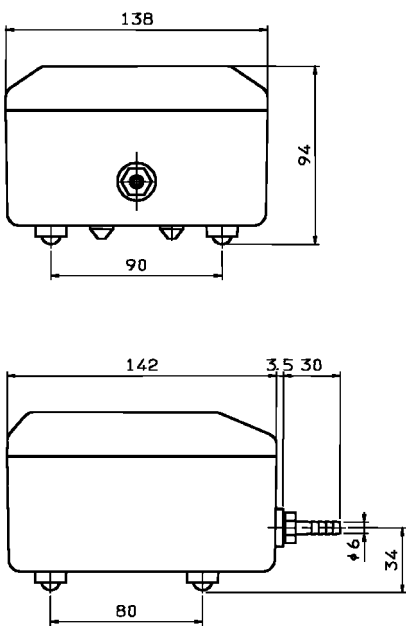

Technical data

Model			MKC-510V
Air flow ¹⁾	l/min	0 mbar	20
		50 mbar	15
		100 mbar	11
		150 mbar	6
Voltage ²⁾	VAC		230
Power consumption	W	100 mbar	9
Noise level	dB(A)		30
Dimensions	mm	L x W x H	175.5 x 138 x 94
Connection	mm	Ø outside	6
Net weight	kg		1.2

¹⁾ Product performance may vary +/- 10% from performance curves
²⁾ Values at 50 Hz

Performance data

Optimal operating span

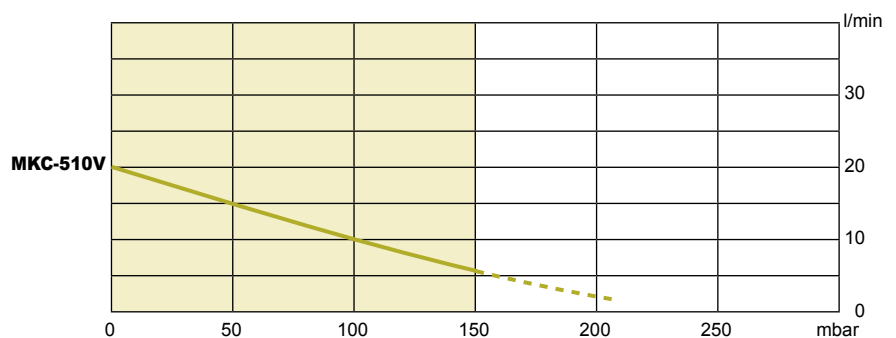

AIR OPERATED DIAPHRAGM PUMPS

Service Kits

With our light- and dust-resistant replacement part sets, you can replace the worn parts of the pumps quickly and inexpensively. The systems can be start-

ed up again within a short time. You do not have to invest in a new diaphragm pump.

Diaphragm and Diaphragm Repair Kits



Magnet Kits



Accessories

To provide your pump with dependable protection against backpressure, we suggest installing a pressure relief valve in the pumps discharge line.

Therefore we provide a back pressure gauge. The pressure relief valve and back pressure gauge are both of compact construction and maintenance free.

This allows the pump to return to a safe working design pressure by venting any excess pressure to the atmosphere.

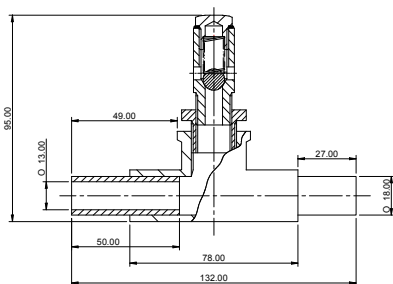

Pressure Relief Valve 3/4"

Pressure Relief Setting	Dimensions (L x W x H)	Connection	Net Weight
0.20 bar	132 x 30 x 95 mm	18 Ø mm	0.5 kg

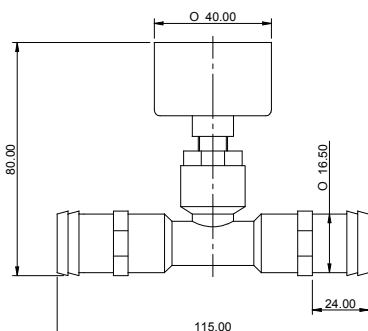

Back Pressure Gauge 3/4"

Pressure Gauge Range	Dimensions (L x W x H)	Connection	Net Weight
0 - 1 bar	115 x 40 x 80 mm	16.5 Ø mm	0.25 kg

DIAPHRAGM PUMPS

Technical References

The following explanations are to help interpret technical data, performance diagrams and dimensioned drawings correctly.

Air flow

Air flow in reference to the corresponding operating pressure

Optimal operating span

Pressure range at which the diaphragm pump can operate continuously.

Special care is necessary, when the pump is operating in the range of maximum working pressure. Please enquire our technical support for special cases.

Power consumption

Input wattage that appears at the stated pressure. The power consumption is at open flow. An exact curve about power consumption is available on request.

Operation mode

Our pumps are designed and produced for permanent operation if the use complies with the operating conditions.

Power supply

All data given refer to an electricity supply of 230VAC / 50Hz, with variations up to +/- 10% are acceptable. All models also run with a frequency of 60 Hz, however with varying performance. Models for other tensions are available on request.

Overload protection

The SLL, SV and EL series are supplied with an integrated thermal overload protection. The contact breaks when the temperature of the windings reaches hazard value of the probe at 130°C until the coil has cooled down below 120°C.

Protection class

Phoe-niX series: IPX4, SLL series: IP45, EL series: IP44

Ambient temperature

The maximum ambient and suction temperature ranges from -10 to +40°C.

Insulation class

All models have the insulation class „E“, which corresponds to a temperature limit of 120°C.

Life expectancy

The working life depends on the operating conditions (duty cycle, operation pressure or vacuum, etc.) and the work environment (ambient temperature, air quality, ventilation, maintenance, etc.).

Protective switch (auto stopper)

Our diaphragm pumps are equipped with an auto-stop function and an LED lamp that signals a possible diaphragm break on the outer enclosure. In addition, the auto-stop function interrupts the power supply to the motor should a diaphragm ever be broken. This prevents further consequential damage, which could be severe, to the diaphragm pumps and the connected systems.

Fault alarm lamp (optional)

To indicate any diaphragm fault optically, every pump of the EL series is provided with a fault alarm lamp. On customer request there is also the possibility to register faults alternatively by an integrated signal cable.

Test conditions

The information presented in this catalogue is based on technical data and test results of nominal units. The measured values refer to a power supply of 230VAC / 50 Hz and an ambient temperature of 15 to 25 °C. The volume flows were measured with air.

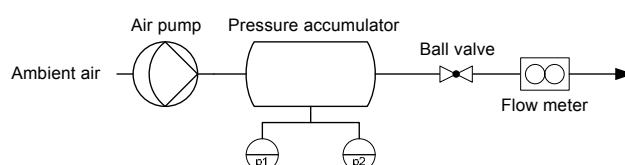

DIAPHRAGM PUMPS

Installation and operation

Installation

The pump must always be installed above the water level. If the pump is set below, the back-flowing water can cause an electrical short circuit.

The pump should be installed at least 10 cm higher than the foundation on a stable platform. If installed on an unstable base, noise from vibrations can result. The pump must be located on a levelled platform to prevent biased strain on the diaphragm that could lead to reduced component life of the blower.

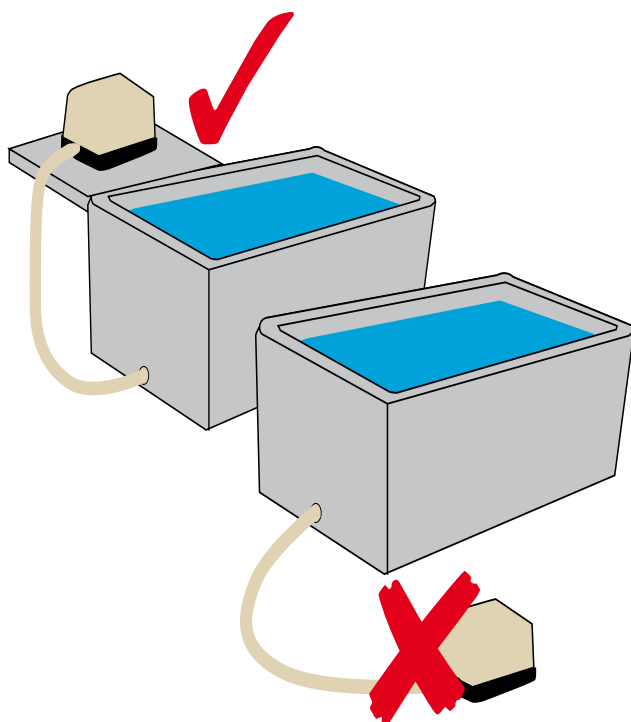

Ambience

Ensure that the unit has good ventilation, especially when subjected to severe operating conditions. If installed in a control cabinet, sufficient ventilation by louvered vents is essential. A cool ambience will ensure longer diaphragm and valve life. The diaphragm blowers are weatherproof. However, they should not be exposed to direct sunlight, rain or snow.

Air quality

The diaphragm pumps are specially developed for transporting air. They should not be operated in a dusty environment. The blocked filter may cause overheating. The atmosphere humidity should not be higher than 90%. Inflammable or aggressive gases and vapours should not enter the pump as the flow path leads to current-carrying parts.

Piping

Select tube size, lengths and accessories to keep pressure loss as small as possible.

Apply:

- straight piping and as short as possible
- tubing, which diameter is bigger than the port of the unit (inside diameter min. 19 mm, respective 25 mm for EL twin system)
- large radius bends and no elbows
- valves of bigger diameter than the blower's connector port
- smooth-running valves that provide the lowest pressure drop
- low air loss diffusers for aeration (also see accessories on page 78)

Maintenance

Clean the filter regularly and replace broken diaphragms immediately. Complete repair kits are available.

Storage

The pumps may not be stored at less than -10°C . The permanent magnet would be weakened in such a case, and the performance would not be as expected. The pump may not be stored in direct sunlight or at high temperatures to maintain the rubber parts flexible.