

MechSpace

734993 Catalog 2006-01-01

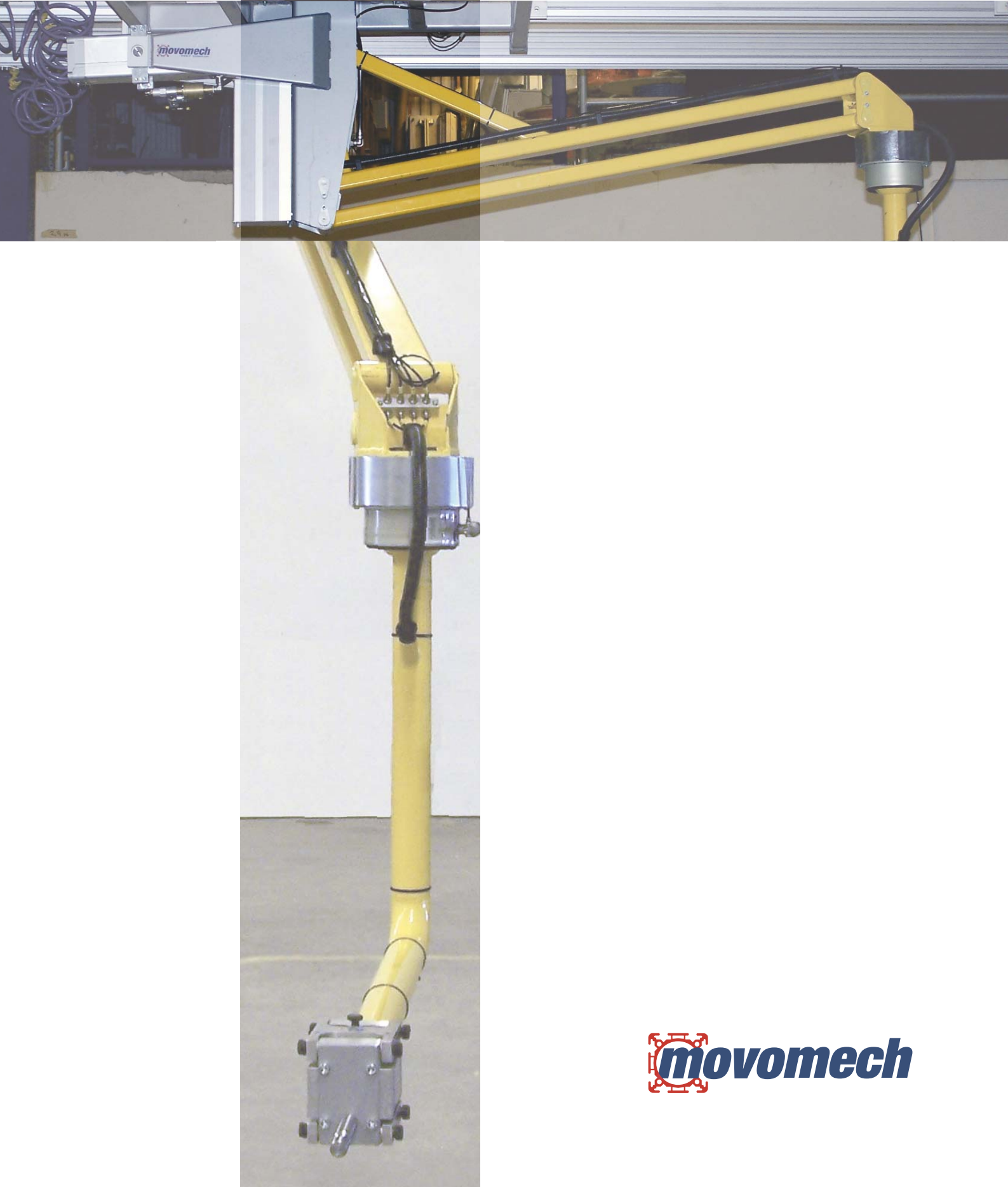

 **movomech**

Contents.....	Page
Basic model.....	4
Suspensions.....	5
Tool adapter.....	6
Pneumatic.....	7
Control unit.....	9
Optional products.....	11

Although the greatest care was taken regarding the information in this catalogue, we assume no responsibility for any errors. We reserve the right to make changes.

ILLUSTRATIONS – The illustrations in the catalogue represent the described products, but the delivered goods may differ in some respects from the illustrations.

SPECIFICATIONS – The right is reserved to make changes in design and dimensions compared with the information in the catalogue in order not to prevent development of designs, material and manufacturing methods.

The customer is reminded that in the purchase of Movomech's products for application on the job or elsewhere, there is supplementary, current information that could not be included in the catalogue in terms of recommendations on each product's suitability regarding different combinations of Movomech's comprehensive product line.

All relevant information must be provided to the persons who are responsible for the application of the product.

How to order...

#1 Basic model

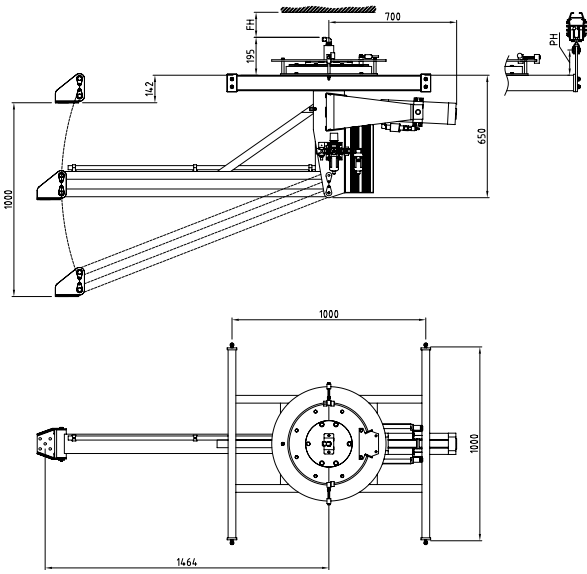

#2 Suspensions

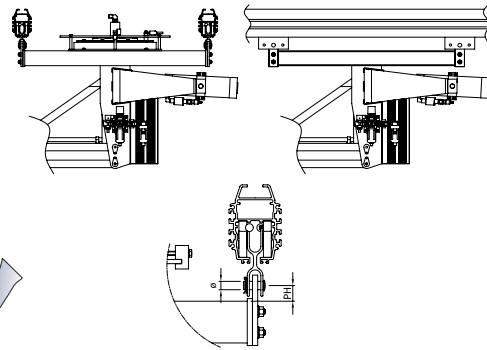

#3 Tool adapter

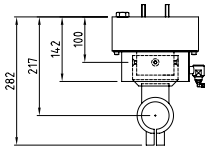

#4 Pneumatic

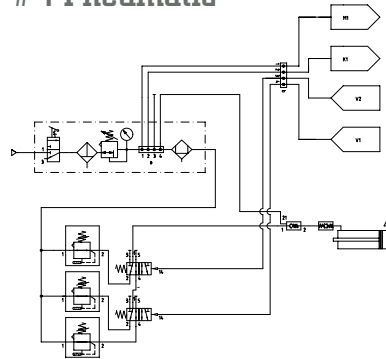

#5 Control unit

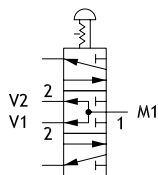

#6 Optional products

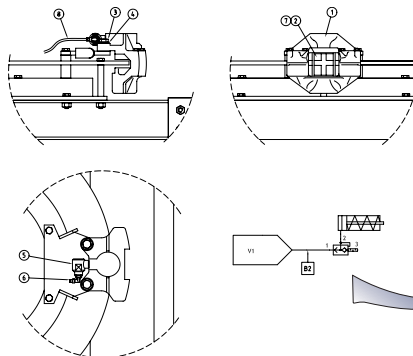

Technical data

Load capacity 70 kg	Noise level < 70 dB (A)	Hoisting speed 0-40 m/min	Rotation 0-310° 0-360° (option)	Maximum tare weight 125 kg
Medium Air Non-lubricated	Working pressure 5,5 bar	Air consumption 600 l _v /min	Working temperature 5-40°C	Maximum torque 500 Nm

Basic model

Article	733284
---------	--------

- FH = Upper clearance, min 50 mm
- PH* = Height of suspension

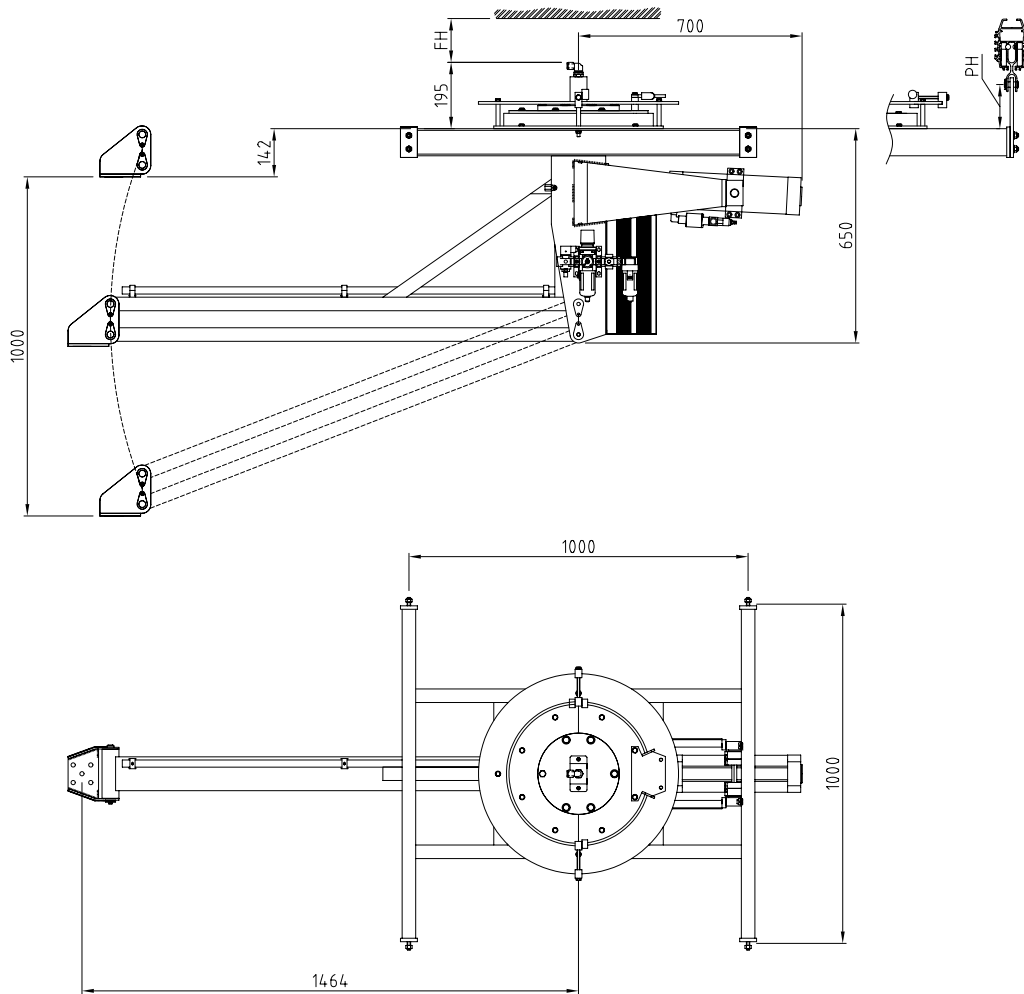

INFORMATION

Add:

- Suspensions page 5
- Tool adapter page 6
- Pneumatic configuration page 7
- Control unit page 9
- Optional products page 11



PH	ø Mounting hole		
	12,5	16,5	20,5
50	733833	733835	733837
>50<500	733834	733836	733838

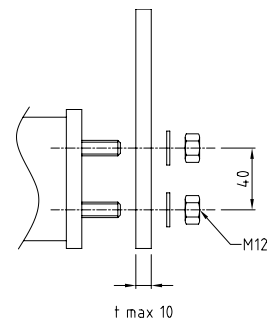
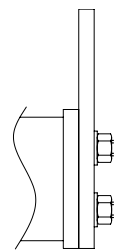
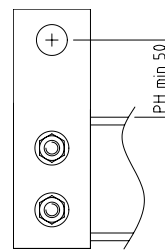
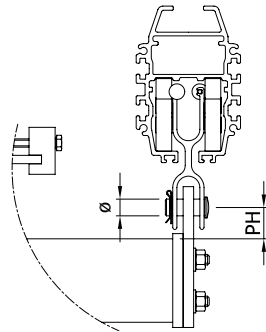
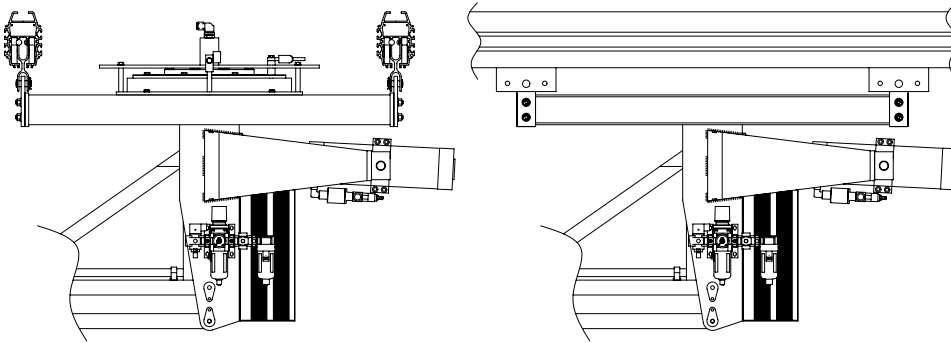

INFORMATION

ø Mounting hole:

12,5 = LHB

16,5 = AHB1-2

20,5 = AHB3

Rotation unit, combined with..

..muff coupling	..mounting bracket	..mounting pipe
732222	732223	732224

732222

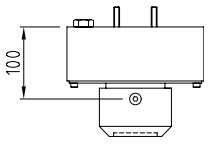

732223

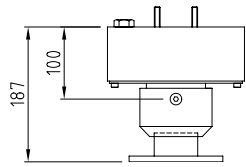

732224

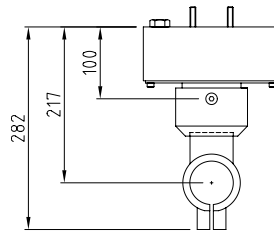

Rotation unit with brake, combined with..

..muff coupling	..mounting bracket	..mounting pipe
732219	732220	732221

732219

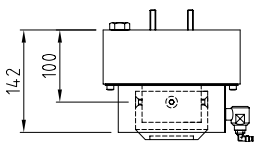

732220

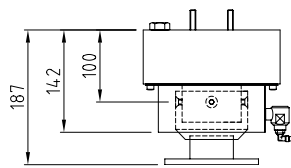

732221

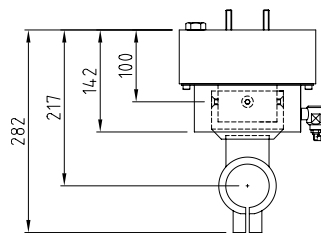

Rotation unit

732067

732067

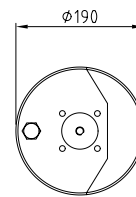
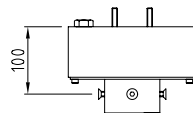

Rotation unit with brake

732068

732068

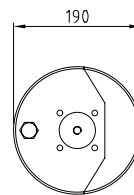
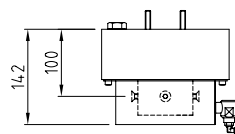

Muff coupling

731497

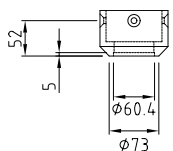

Mounting bracket

731548

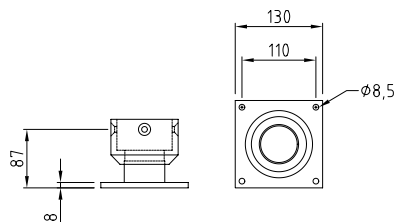

Mounting pipe

734655

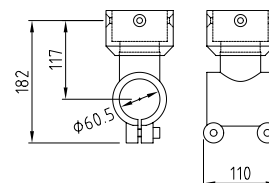

INFORMATION

Braking force: 113 Nm at 0 rpm

1-weight

733812

INFORMATION

0-70 kg
1 load

K1 = connecting pneumatic tool
(5,5 bar => 160 l_n/min)

Connections (available)
a: 1,3
b: 1,3,4

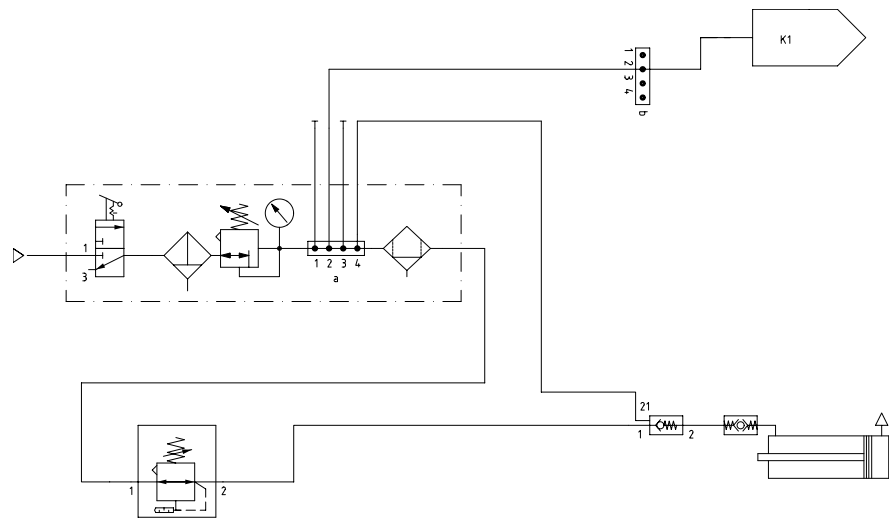

2-weight

733813

INFORMATION

0-70 kg
2 loads

K1 = connecting pneumatic tool
(5,5 bar => 160 l_n/min)

M1 = air supply control unit
V1 = signal from control unit

Connections (available)
a: 3
b: 3

Recommended control unit

733591 Selector switch 2 fixed positions

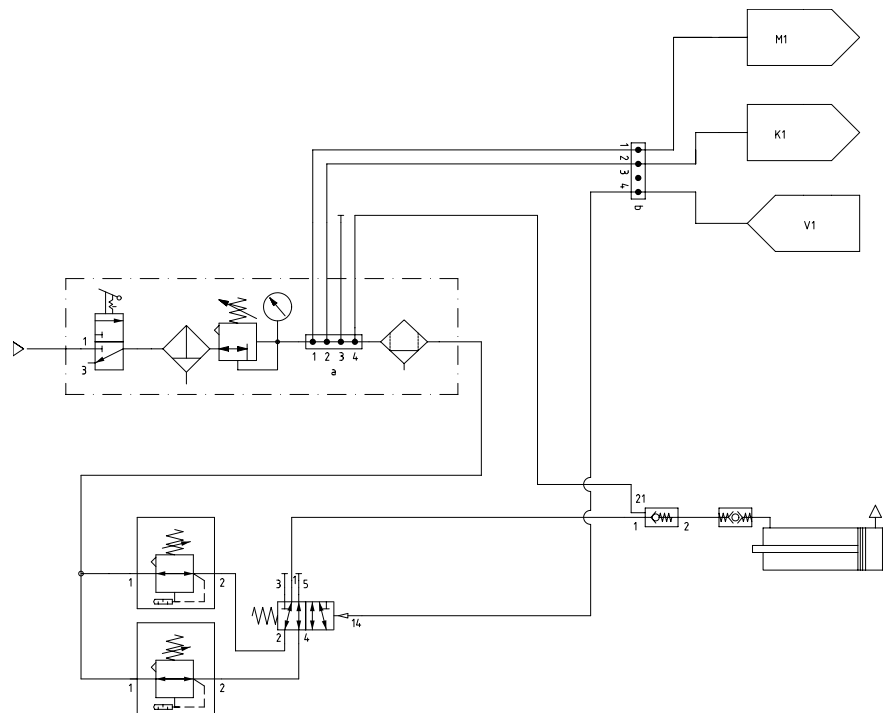

3-weight

733814

INFORMATION

0-70 kg
3 loads

K1 = connecting pneumatic tool
(5,5 bar => 160 l_n/min)
M1 = air supply control unit
V1 = signal from control unit
V2 = signal from control unit

Connections (available)

a: 3
b: -

Recommended control unit

733592 Selector switch 3 fixed positions

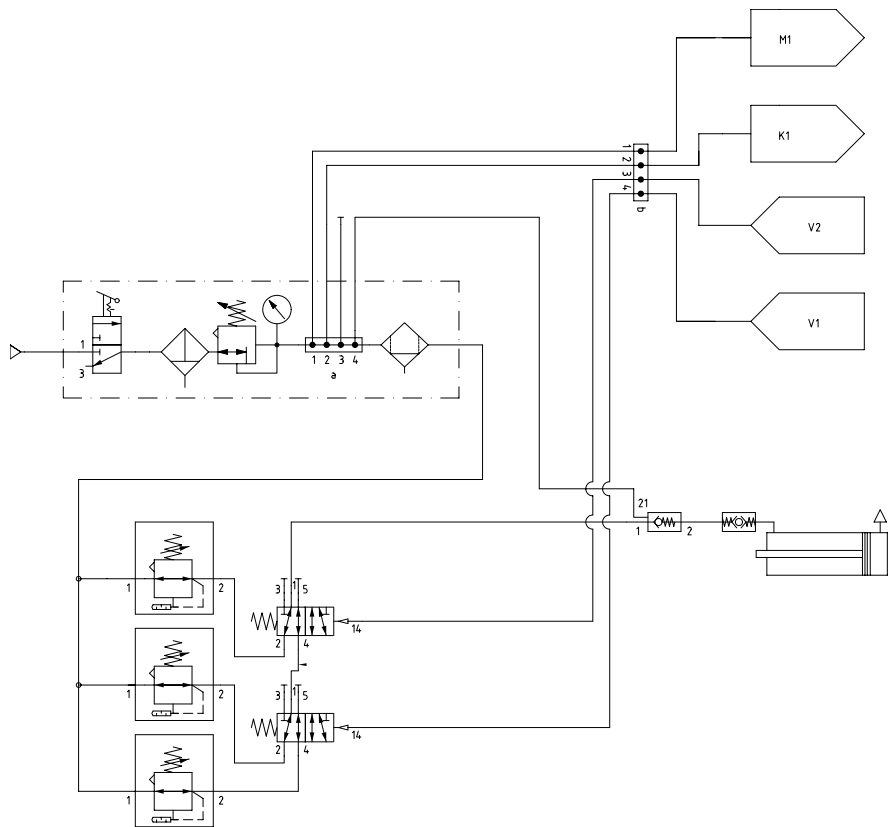

Pilot control

733811

INFORMATION

0-70 kg
Variable load

K1 = connecting pneumatic tool
(5,5 bar => 160 l_n/min)
M1 = air supply control unit
V1 = signal from control unit

Connections (available)

a: 3
b: 3

Recommended control unit

731386 Parallelogram
731853 Throttle 1,7 Bar
731854 Throttle 3.4 Bar

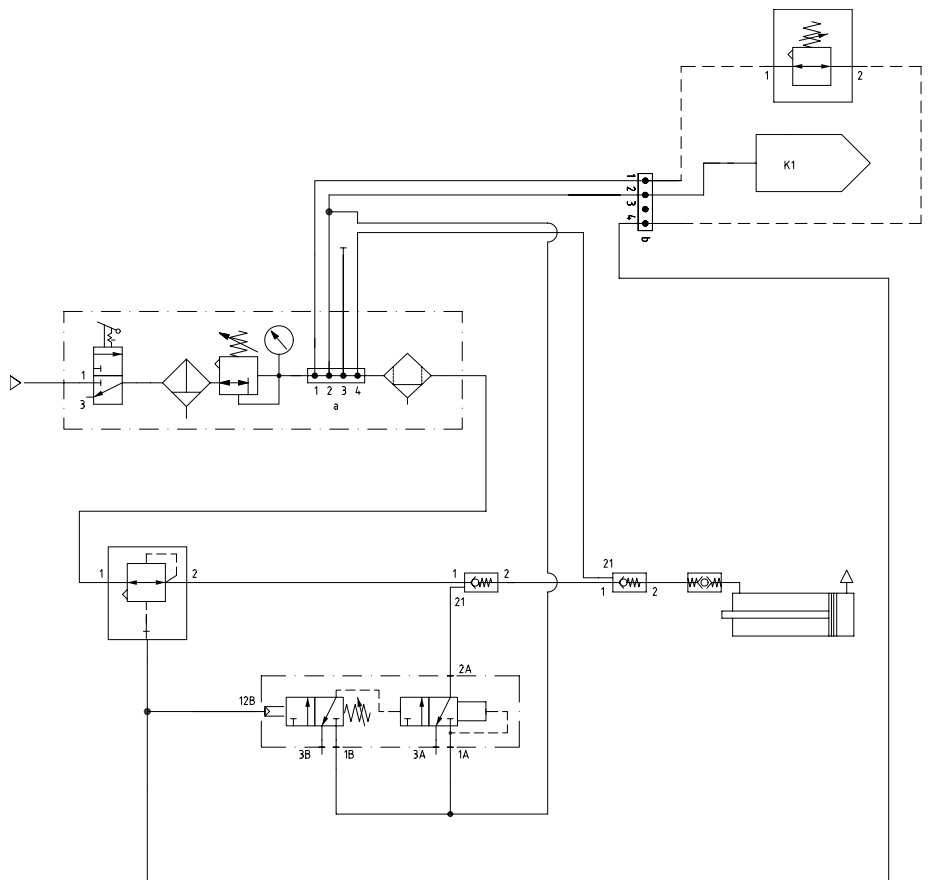

Selector switch

733591

2 fixed positions
NC

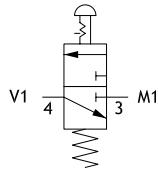

Selector switch

733592

3 fixed positions
NO

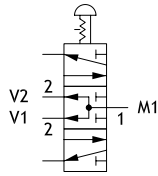

Limit switch with ball actuator

733593

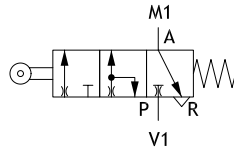

Roller lever valve

733594

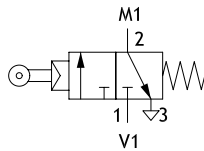

Swivel lever valve

733595

Combine with lever below

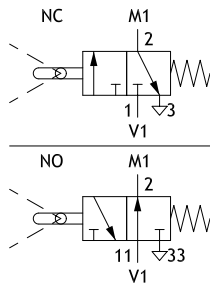

Lever

Type

A	Short swivel lever	733589
B	Long swivel lever	732943
C	Rod swivel lever	733512



Throttle

Bar	
1.7	731853
3.4	731854

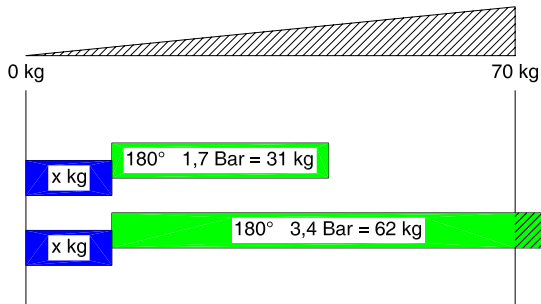
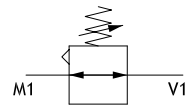

- Tool
- Operating range
- Warning overload!
Mechanical restriction is mandatory.
- + ■ --> max 70 kg

Parallelogram

731386

Max. allowed load in parallelogram is 70 kg!
Operating range variable load: 50 kg (max. 40 kg recommended).

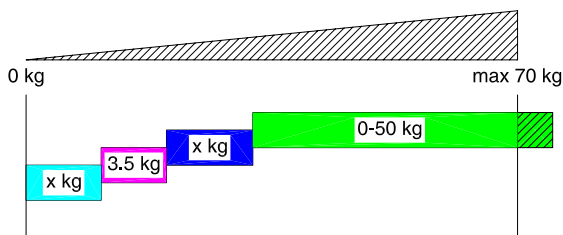
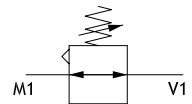

- Parallelogram
- ■ Tool
- Operating range
- Warning overload!
Restrict load.
- + ■ + ■ + ■ --> max 70 kg

INFORMATION

For further information, contact Movomech

Brake unit
Pneumatic

731505



INFORMATION

Components for operation is ordered separate, contact Movomech



Movomech AB

Box 9083
SE-291 09 Kristianstad
SWEDEN

Phone +46 (0)44 28 29 00
Fax +46 (0)44 28 29 28
E-mail info@movomech.com
Web www.movomech.com

Representatives

Sweden
Belgium
Denmark
Finland
France
Germany
Ireland
The Netherlands
Singapore
Spain
UK
USA