



Driven by performance

Dust filter cartridge

328 XZ

Ø 328 mm, high performance cartridge

1. Features

This high-performance dust filter cartridge was developed by MAHLE Filtersysteme for particularly challenging filtration tasks in the pharmaceuticals and chemical industries.

This cartridge design facilitates optimum cleaning of the filter cake in conjunction with the MAHLE rotating wing. Typical dust deposits are virtually eliminated by completely filling the bottom of the end cap, because almost all deposits on the cartridge are drained off during cleaning. The key features here are the MAHLE rotating wing and the special pleats, which are supported in an innovative way.

The unique design of these cartridges permits wet cleaning with the element installed or removed.

Characteristics

- Washable
- Very high differential pressure stability
- Installation on the dirt side
- Improved cleaning properties
- High load capacity
- Worldwide distribution



2. Technical Data

Material

Inner core:	Stainless steel V4A - AISI 316
End caps:	Stainless steel V4A - AISI 316
Seal:	Silicone foam
Filter material:	DRG 5N - Stainless steel wire mesh - AISI 316
	Ti 07 - Electrically conductive polyester fleece with PTFE membrane
	Ti 08 - Electrically conductive polyester fleece
	Ti 18 - Polyphenyl sulphide with PTFE membrane
	Ti 56 - Polyester fleece with PTFE membrane and pleats supported by wire mesh
	1100 µm

Cleaning

Nozzle:	Rotating wing
Cleaning pressure:	3 bar to 4 bar
Differential pressure:	max. 30 mbar
Compressed air consumption per cleaning pulse:	50 l (fad) for L = 600 mm 100 l (fad) for L = 984 mm

Compressed air

reservoir capacity:	approx. 16 l per filter cartridge for L = 600 mm approx. 32 l per filter cartridge for L = 984 mm
----------------------------	--

Technical data is subject to change without notice!

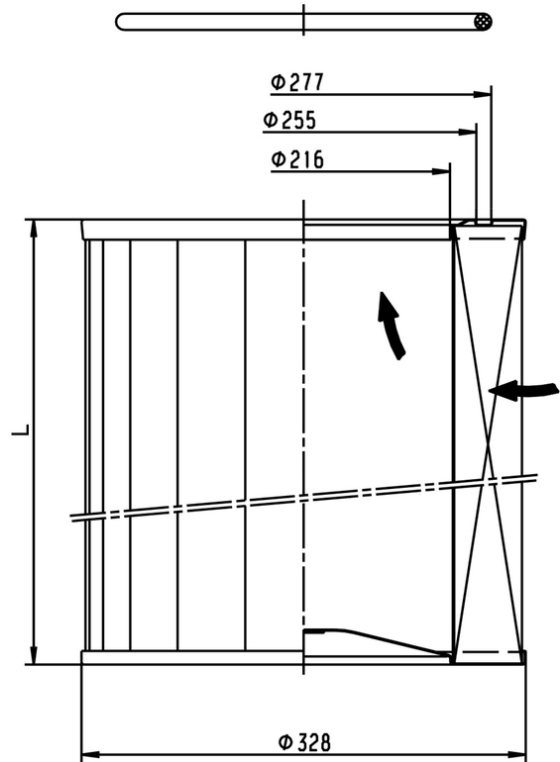

3. Order numbers

Order number	Type designation	Length L [mm]	Filter material	Filter surface [m ²]	Max. vol. flow** [m ³ /h]	Max. operating temperature [°C]	Electr. conductive
79747072	852 844 DRG 5N-3 V4A FRV*	600	DRG 5N	3	650	240	yes
78361370	852 844 Ti 07-3 V4A FRV*		Ti 07		550	130	
78361388	852 844 Ti 07-5 V4A FRV*	600	Ti 07	5	800	130	yes
78215295	852 844 Ti 08-5 V4A FRV*		Ti 08		450		
76105969	852 844 Ti 18-5 V4A FRV*		Ti 18		800	160	no
78221376	852 844 Ti 56-5 V4A FRV*		Ti 56			130	
76355499	852 979 Ti 07-8 V4A FRV*	984	Ti 07	8	1200	130	yes
79749664	852 979 Ti 18-8 V4A FRV*		Ti 18			160	no

* Version made of stainless steel V4A - AISI 316 or equivalent with glued pleat backs

** These values may vary depending on the nature of the dust and the composition of the gas.

4. Installation

The dust filter cartridges 852 844/852 979 are fastened to the filter plate on the dirt side by means of a tie bolt (tightening torque approx. 15 Nm). A hole with a diameter of 214 mm must be drilled in the filter plate. Cartridge mounting is facilitated by a centre ring.

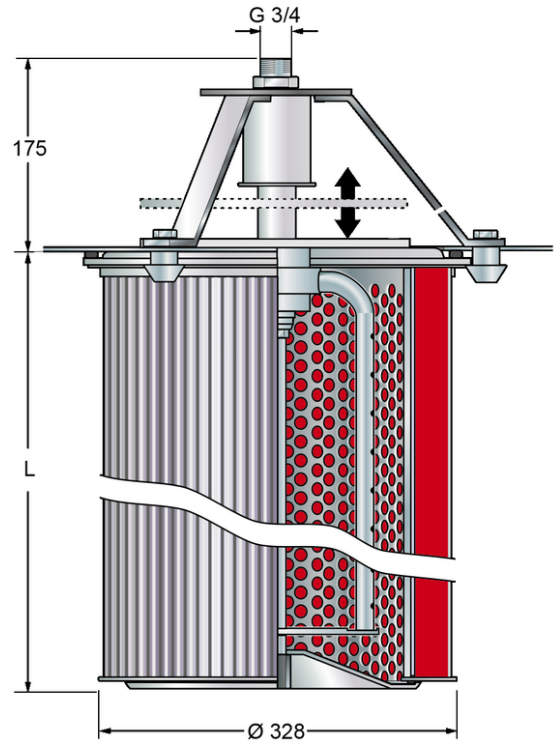

5. Accessories

Order number	Designation
77934326	Centre ring stainless steel V2A - AISI 304
79743709	Centre ring stainless steel V4A - AISI 316
79749631	O-ring silicone 253 mm x 12 mm
79339219	RLD-32 06 ROH V2 - AISI 304
79790064	RLD-32 10 ROH V2 - AISI 304

6. Cleaning

We recommend cleaning the dust filter cartridge with MAHLE rotating wing RLD.

At begin of the cleaning process the baffle plate closes and the wing starts to rotate. Numerous air jets allow for even, gentle cleaning of the complete cartridge length. The cleaning process is significantly more efficient due to the simultaneous vibration movement in the pleats, particularly important with critical dusts. Each pleat is cleaned repeatedly.

By using the rotating wing the optimal service life of the filter cartridge is guaranteed.

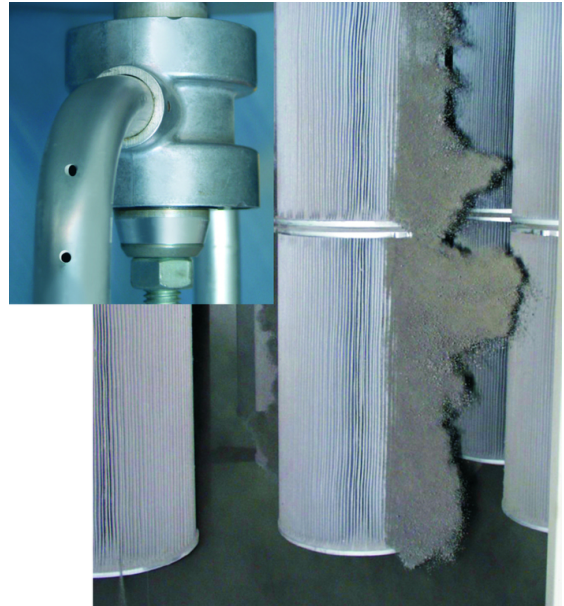

7. Design

Please contact us for detailed technical information, any open questions and for general expert advice. Completion of the relevant questionnaire would facilitate in the coordination of all important parameters.

Comprehensive documentation on our product range, cleaning units and cartridges can be provided.

MAHLE Industriefiltration GmbH
Schleifbachweg 45
D-74613 Öhringen
Phone +49 7941 67-0
Fax +49 7941 67-23429
industriefiltration@mahle.com
www.mahle.com
70342680.04/2015