

MAHLE

Driven by performance

Duplex filter

VS87-1

With smooth-running vessel change-over, rated pressure up to 16 bar (232 psi)

Connection sizes: DN 100 to DN 250, cast design

1. Features

High-performance, continuous filtration

- Used in shipping and industry
- Continuous filtration supports rational production processes
- Filtration efficiency due to interruption free operation
- Mature engineering and robust design
- Compact design
- Elements with high differential pressure stability (up to 5 bar → unrivalled) and dirt holding capacity
- Filter ratings from 25 to 5000 μm absolute, other ratings on request
- Suitable for use with fluids of all types
- Easy to service
- Worldwide distribution



2. Operating principle

- The two bowls of the duplex filter are each fitted with a filter element (smooth or pleated) through which the medium flows from the inside to the outside.
- One filter bowl is pressurised during operation to allow the medium to flow through the filter element in the required direction.
- The filter changes over to the second bowl without interrupting the filtration process when a settable fouling threshold is reached.
- The non-operational bowl can then be opened and the filter element removed for cleaning.
- Duplex filters require no maintenance apart from cleaning the filter elements and inspecting the seals.

3. Technical Data

Connection:	DN 100 to DN 250
Flange Type 1:	DIN 2501 PN 16
Material:	Nodular cast iron
Max. operating pressure Type 1:	6 bar
Max. operating pressure Type 2:	16 bar
Test overpressure Type 1:	9 bar
Test overpressure Type 2:	23 bar
Max. operating temperature:	180 °C
Filter element:	Screen basket, cartridges
Filter rating:	25 to 5000 µm absolute, other ratings on request

4. Dimensions

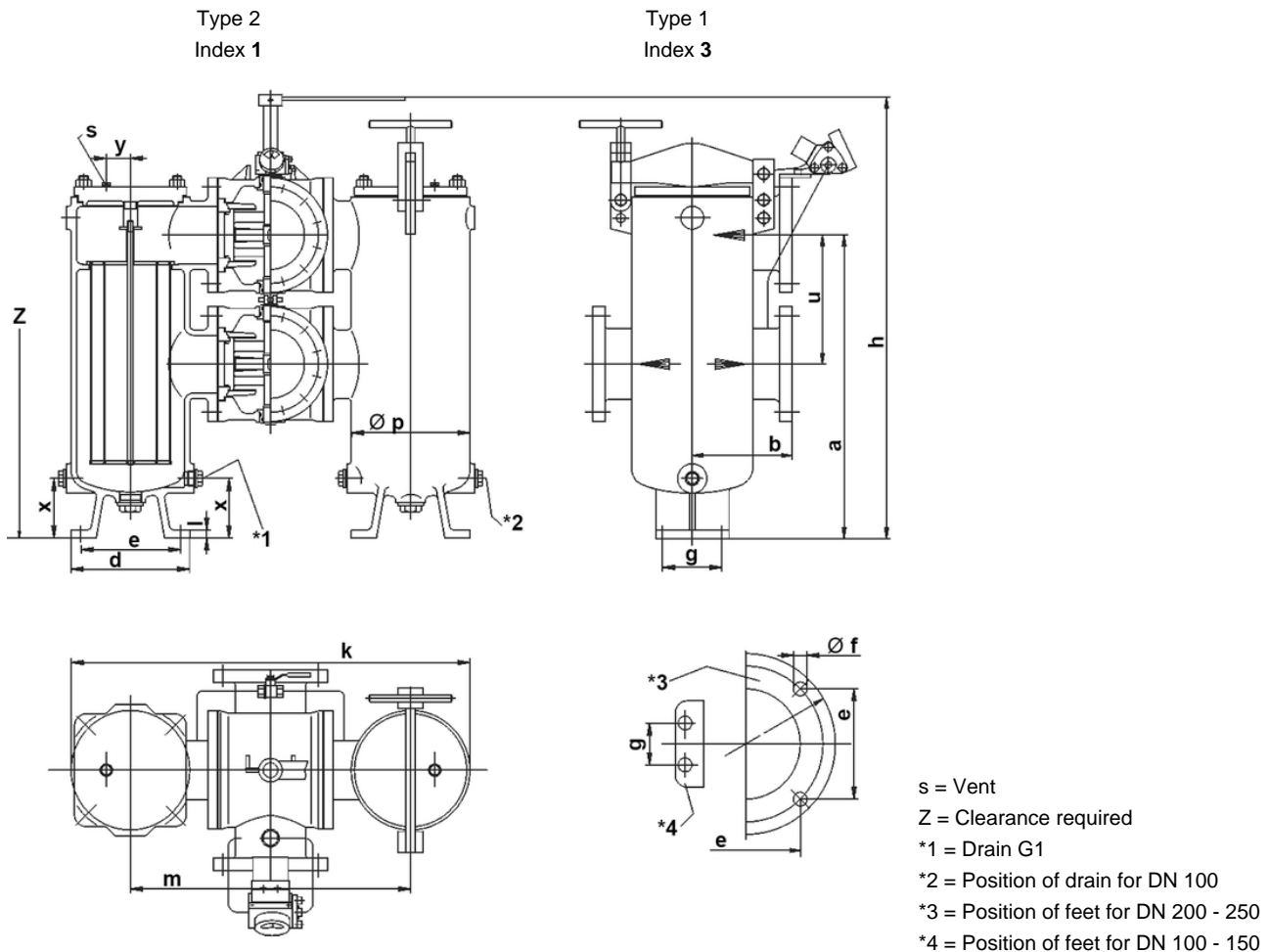

All dimensions except "s" in mm.

Type	DN	a	b	d	e	Ø f	g	h	k	l	s	m	p	u	x	y	Z	Weight [kg]
CE103**0A09	100	480	180	220	180	18	70	720	800	16	G1/4	550	204	250	90	50	980	200
CE113**0A10	125	660	200	260	220	18	170	925	960	18	G3/8	644	260	270	130	80	1320	296
CE123**0A11	150	760	210	320	270	23	200	1035	1090	20	G3/8	724	308	310	135	100	1500	390
CE143**0A13	200	810	240	290	176	23	-	1175	1310	20	G3/8	862	384	350	90	120	1695	645
CE153**0A92	250	1070	270	302	184	23	-	1430	1390	20	G3/8	944	390	405	90	120	2200	787

* first position: insert index "1" for flange position on the same side, insert index "5" for flange position opposite each other

* second position: insert index "3" for type 1, insert index "1" for type 2

5. Design and application

A wide range of filter elements are available for every duplex filter. The material, type of construction and filter surface and rating are expertly adapted to the specific filtration task based on the medium and capacity.

Each duplex filter can be supplied with various options to ensure the optimum performance for each particular application.

Options:

- Heating (steam/thermal oil, electric)
- Magnetic elements
- Differential pressure indicator/switch mounted on the filter
- Automatic switch-over

Duplex filters are not at all complicated to use and they guarantee continuous filtration. The necessary steps are described in the following:

- The filter comprises two bowls with a cover and a parallel unit.
- Each bowl contains a vent port, a drain port and a filter element.
- The filter must be filled and vented before it is put into service. Make sure the liquid flows through the filter in the direction indicated by the arrow, so that it enters the filter element at the top.
- Cylindrical elements are used for the filtration process. Impurities are trapped in the element and removed together with the latter when it is withdrawn from the housing for cleaning. The inside of the housing is permanently dirt-free as a result.
- The filter must be changed over and cleaned when a differential pressure of approx. 7 m/water column is reached. This is done by turning the spanner in the direction of the other bowl. The spanner should be applied according to the marking. The flow direction of the medium in the pressurised bowl is indicated by a marking on the stopcock spanner hub.
- If the filter has a pressure balance pipe, the valve for this pipe must be opened and closed again prior to changing over to the other bowl.
- After the filter has been changed over, the cover of the non-pressurised bowl can be opened and the element lifted out vertically. To clean the filter element, either flush or blow it out or brush it with a soft brush. Carefully insert the cleaned element again vertically. When the cover is closed, the element is pressed against the support ring by means of the cover spring.
- The filter must be mounted without stress on flanges and feet.
- If the medium has a tendency to form deposits, the filter must not be allowed to run dry.

6. Type number key

Type number key with selection example for VS87-1 valve filter DN 100 to DN 250

Main product group

C Duplex filter, cast design

Series

E Duplex filter with valve switch-over

Inlet and outlet connections

10 Flange DN 100

11 Flange DN 125

12 Flange DN 150

14 Flange DN 200

15 Flange DN 250

Filter connection standard + rated pressure

3 EN 1092 PN 16 bar

Position of main connections

5 Opposite each other, offset pattern

Cover fastening

3 Retractable screwtop

Options

0 Standard version

2 Electric cartridge heater

3 Steam/thermal cartridge heater

7 Version without non-ferrous metals

G Rubber coating

Type of inner assembly

A Filter elements for simplex filter

Inner assembly size

XX

Housing version

2 Nodular cast iron

Parallel unit material

2 Nodular cast iron

Number for special types or design features

XX

01

C E 11 3 5 3 0 A 10 2 2 01

MAHLE Industriefiltration GmbH
 Schleifbachweg 45
 D-74613 Öhringen
 Phone +49 7941 67-0
 Fax +49 7941 67-23429
 industrialfiltration@mahle.com
 www.mahle.com
 70381746.04/2015