

MAHLE

Driven by performance

Oil Mist Separator Unit

LGA 600 FUW

Nominal volume flow 600 m³/h

1. Features

High performance oil mist separator unit for separation of coolant from tooling machine exhaust air

- Compact design
- High oil mist load capacity
- Excellent retention rates
- Quality filters, easy to service
- Equipped with high-efficient coalescer elements
- High dirt holding and optimized service life
- Modular design for direct installation of main components onto tooling machines
- Pre-separation system for optimized service life
- Worldwide distribution



2. Fractional collection efficiency

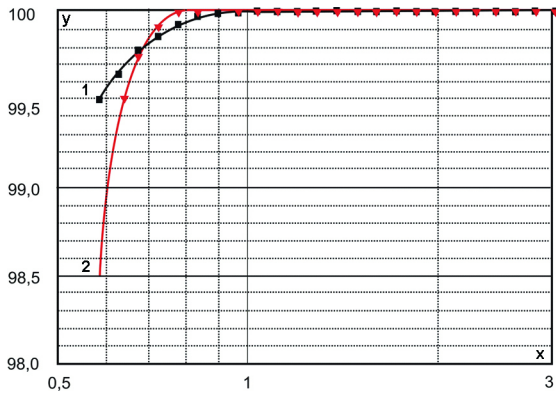

x = Particle size in μm

y = Fractional retention rate in %

Aerosol: Wiolan SH 10

Raw gas concentration: 50 mg/m^3

Volume flow: $600 \text{ m}^3/\text{h}$

1 = Filter cartridge as delivered

2 = Filter cartridge after 100 operating hours

4. Application

Suitable for non-water-miscible cooling lubricants (cutting oil, grinding oil, drilling oil) and oil aerosol exhausted by machine tools and also for water-miscible cooling lubricants.

Operating limits

If oil is used as cooling lubricant for machining processes, air usually has to be sucked away from the working area to prevent the atomized oil from dispersing. The concentrations that often occur in the cooling lubricant jet or in the machine room could result in ignition in case of tool breakage, for example. If the machining process involves flammable cooling lubricants or flammable materials, safe operation must be ensured by providing suitable fire and explosion protection devices in conformance with statutory regulations.

Installation in potentially explosive atmosphere (Zones 0, 1 and 2) is not permitted!

6. Order numbers

Type	Order number
LGA 600 FUW	70384284

3. Operating principle

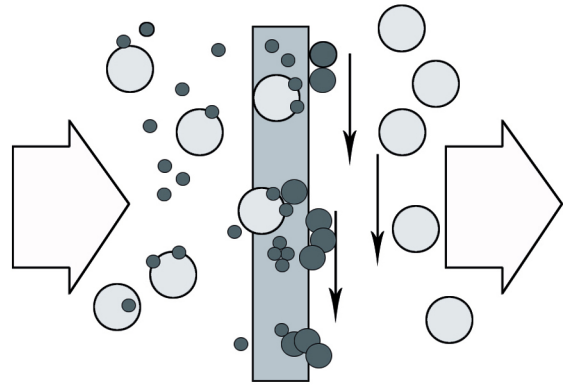

Oil aerosols are sucked away from the machining space of machine tools. The oil-laden air flows outward through the coalescer element from the inside. The oil attaches itself to the fibre media as it passes through the filter. Minute oil droplets "coalesce" to form larger drops. These larger droplets migrate downwards on the coalescer element due to gravity. The oil accumulates at the bottom of the housing and is returned to the cooling lubricant storage reservoir via the oil drain hose and the membrane valve. The vacuum in the filter housing causes external air to be sealed off by the membrane valve. The valve opens automatically when the oil in the drain hose reaches a height of at least 500 mm. The cleaned airflow is sucked away by means of a high-pressure fan and blown out at the top through a silencer.

5. Product information

LGA 600 F

The LGA 600 FUW is a filtering separator with optional pre-separation.

It is driven by a frequency controlled motor. A volumetric flowrate sensor supplies the actual value required to obtain a constant volume flow of $600 \text{ m}^3/\text{h}$. If this value falls below the setpoint, an electrical signal is output at approximately $450 \text{ m}^3/\text{h}$. These signals can be evaluated to enable suitable maintenance action to be taken.

7. Modules/main components

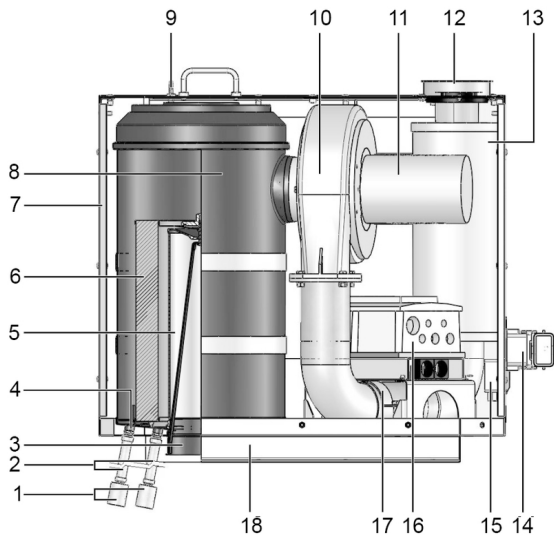

- 1 Membrane valve (2x)
- 2 Oil hose (2x)
- 3 Air inlet nozzle
- 4 Oil drain nozzle (2x)
- 5 Pre-separation element
- 6 Coalescer element
- 7 Housing
- 8 Filter housing
- 9 Eyebolt for transport
- 10 Fan
- 11 Electric motor
- 12 Air outlet nozzle
- 13 Silencer
- 14 Connection port
- 15 Volume flow display
- 16 Frequency converter
- 17 Volumetric flowrate sensor
- 18 Mounting base plate

8. Technical data

Volume flow	600 m ³ /h
Temperature range	+ 10 °C to + 60 °C
Air nozzles (2x Jacob)	150 mmm
Oil hose (2x)	PVC transparent 15x2 mm (3 m)
Filter	1 pre-separation element and 1 coalescer element
Filter surface	4.8 m ²
Dimensions (LxWxH)	930x554x840 mm
Weight	140 kg
Supply voltage	3 AC 400 V/PE, 50-60 Hz
Current consumption	3.3 A
Protection class electrical devices	IP54
Backup fuse	10 A
Connection port	Harting 10B
Motor output	1.5 kW
Motor speed	5920 U/min
Sound level	69 dB (A)

9. Dimensions

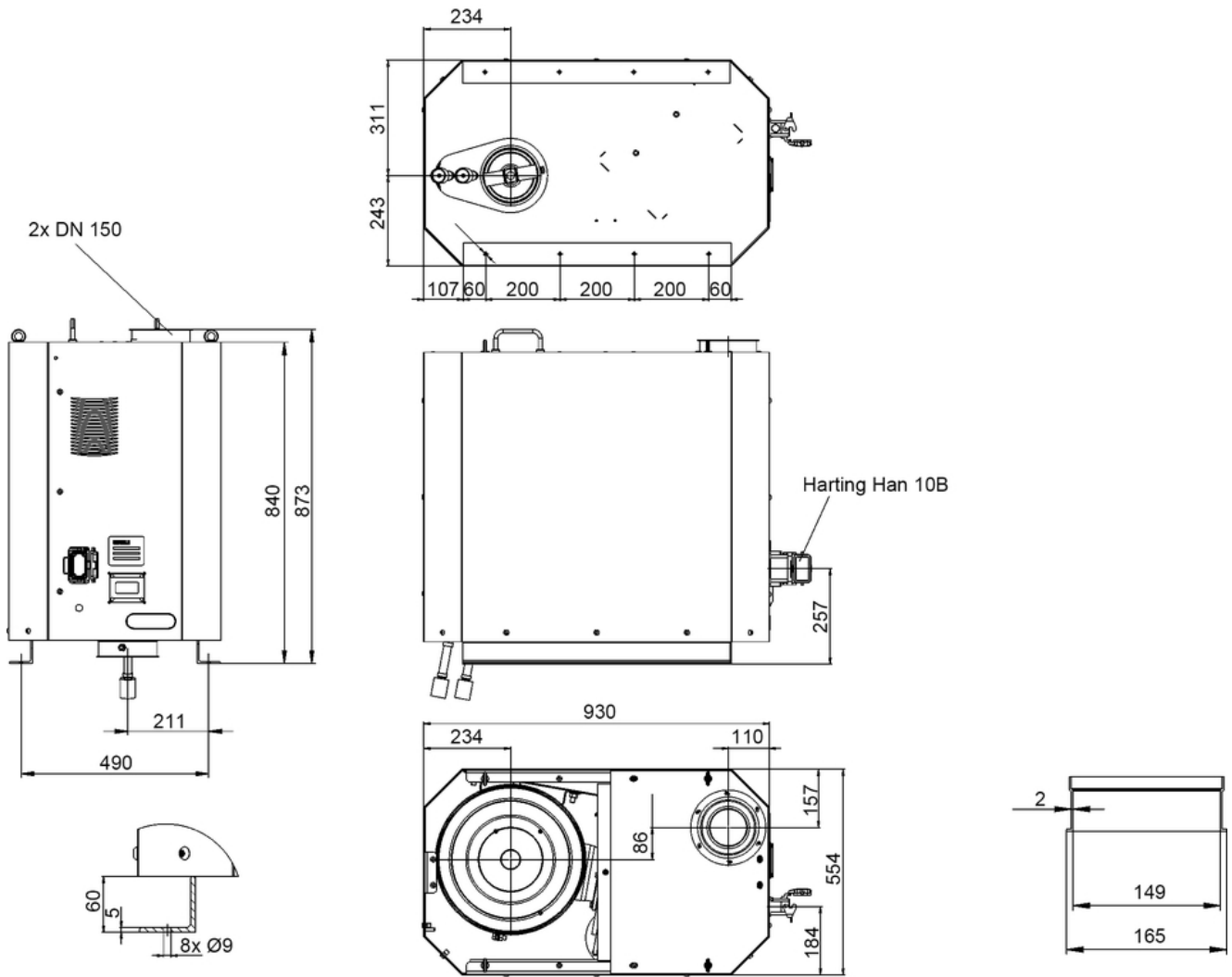

10. Installation

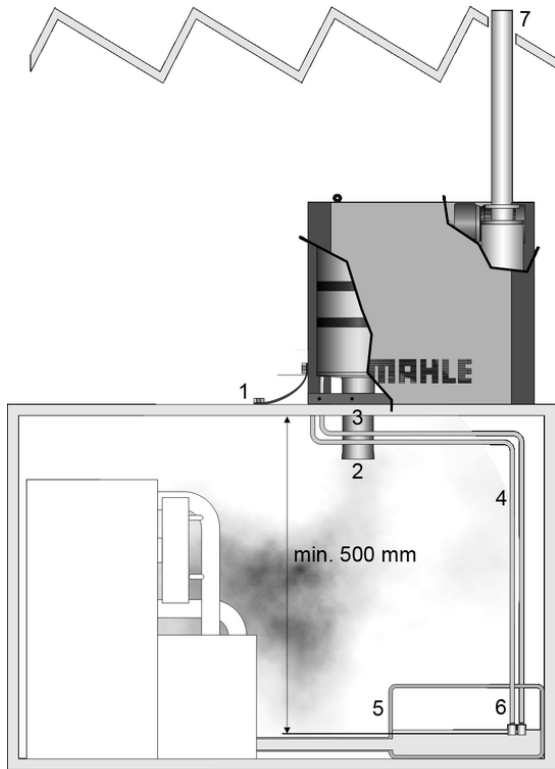

- 1 Equipotential bonding
- 2 Suction pipe
- 3 Air inlet nozzle
- 4 Oil hose (2x)
- 5 Oil storage reservoir
- 6 Membrane valve (2x)
- 7 Exhaust air pipe

Note the minimum clearance of 480 mm is required for element removal!

11. Spare parts and accessories

Order numbers for spare parts and accessories	
Designation	Order number
Pre-separation element	70517413
Coalescer element	79354390
Membrane valve	78769697
Harting easy hood (19 30 010 1540)	70360184
Harting bush insert (09 33 010 2716)	70345233
Jacob pipe nozzle (11151431)	70346551
Jacob clamp ring (12152903)	79389081
Jacob NBR flanged sealing ring (10156951)	76141121
Jacob 90° bend	70365712



Driven by performance

MAHLE Industriefiltration GmbH
Schleifbachweg 45
D-74613 Öhringen
Phone +49 7941 67-0
Fax +49 7941 67-23429
industrialfiltration@mahle.com
www.mahle.com
70517224.04/2015