

Stepper Motor Linear Actuators

Pre-engineered motorized lead screw assemblies and actuators
for precision applications



Stepper Motor Linear Actuator Assemblies

Combining cutting-edge motor and lead screw technologies

Thomson offers three basic configurations – rotating screw (MLS), rotating nut (MLN) and actuator (MLA). The open architecture rotating screw and rotating nut motorized lead screws suit applications where external guidance is present or a high level of design flexibility is required, while the closed assembly of the motorized lead screw actuator is ideal to further simplify the design process and remove requirements for external guidance.

Technology Overview

Rotating screw assemblies (MLS) actuate by having the motor rotate a lead screw and translate a load that is attached to the lead nut. Rotating nut assemblies (MLN) actuate by rotating a nut within the motor body. Motion is achieved by constraining the motor and translating a load attached to the lead screw or constraining the lead screw and translating a load attached to the motor.

Rotating Screw Configuration **MLS**

The rotating screw design, which is ideal for rapid prototyping, features our patented Taper-Lock design to connect the lead screw to the motor shaft. It is best suited for applications where a high level of modularity or customization is required. Users have the freedom to configure an assembly from a range of lead screw, lead nut and motor options as needed for their applications.

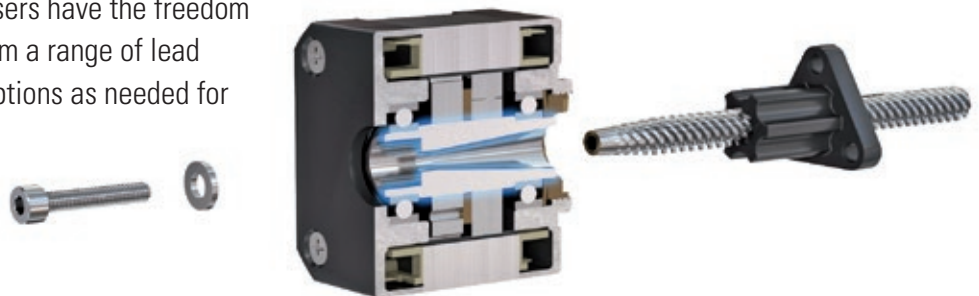

Rotating Nut Configuration **MLN**

The rotating nut design features our patented integration of a lead nut into the motor rotor to maximize screw diameter, which increases load capacity. It is ideally suited for applications where no visible rotation is desired or where it is necessary to translate a load on either side of the motor.

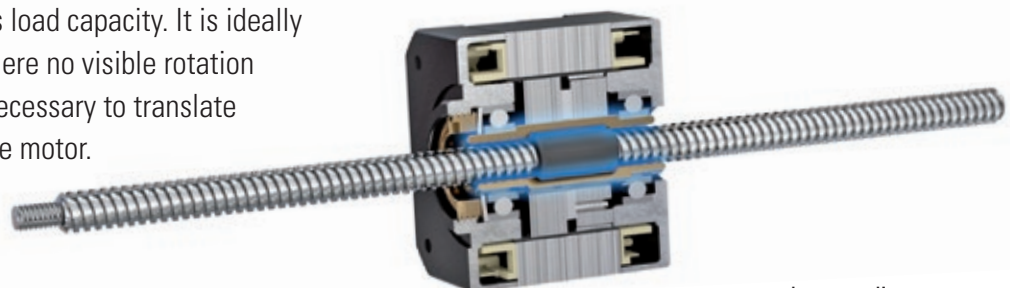

Motorized Lead Screws

Thomson motorized lead screws combine a hybrid stepper motor and a precision lead screw together in one compact envelope. Patented Taper-Lock technology allows quick decoupling and secure, properly aligned connections. This combination offers several advantages over a traditional solution.

Improved Efficiency

Thomson provides a more efficient motorized solution to reduce power consumption, improve operating battery life, and decrease motor footprint. With this improved efficiency, an increase in system load performance or a reduction in power consumption can be expected – all while having a lower cost of ownership.

Increased Torque Density

Thomson motorized lead screws offer increased torque density over alternative solutions. By optimizing the motor performance and matching this with the ideal lead screw and nut design, Thomson has been able to increase the load capacity by up to 30% while maintaining the same motor footprint.

The Taper-Lock Advantage

The robust design of the Taper-Lock provides a secure, self-aligning connection between the lead screw and stepper motor.

Reduced Noise

Thomson can optimize your motor configuration and windings to limit motor harmonics and reduce motor noise at your application operating points.





Motorized Lead Screw Actuators

Thomson motorized lead screws are also available in an actuator configuration (MLA). The actuator is a fully housed solution in which the motion is taken care of for you – simply determine stroke length, linear travel per step or revolution (lead), and precision level to select an appropriate MLA. The actuator configuration offers a complete housing and integrates easily into your assembly with a similar range of end mounting and connection options as the rest of the motorized lead screw family.

Built-in Anti-Rotation

Our actuator configuration includes anti-rotation as standard with every product, eliminating the need for external guidance.



Side Load Capability

Actuator configurations are able to withstand some side and moment loading due to the bushing design included inside the assembly. Depending on load, speed and motion requirements, MLA assemblies can withstand a side load of up to 10% of axial capacity of the motor. For optimal performance, side and moment loads on MLA configurations should be minimized and avoided in the fully extended position.

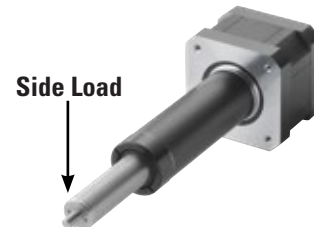

Actuator Configuration MLA

The actuator is a fully housed motorized lead screw with a rotating screw configuration and your choice of end machining. This version simplifies your design process by enabling you to select a product based on linear travel per motor rotation and by including anti-rotation as standard, with no external requirements for guidance.

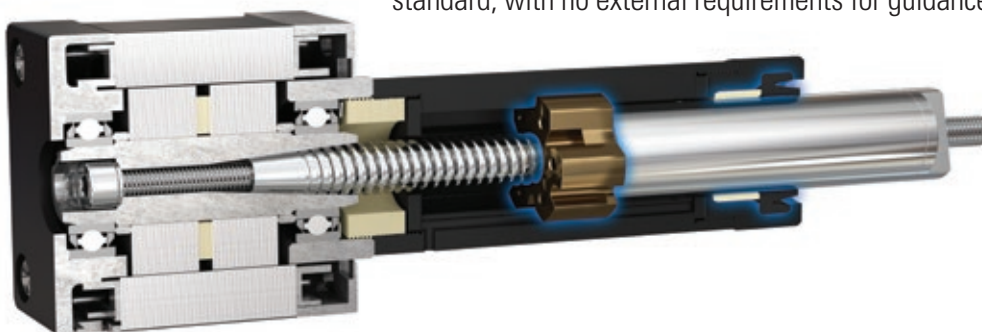

Thomson Advantage

The Thomson Taper-Lock

Fixing the motor to the lead screw usually requires a coupling assembly (A), a counter-bore press fit (B) or a hollow shaft press fit (C). The assembly process may also entail the use of adhesives or welding, but the bottom line is that all these solutions make it difficult or impossible to change lead screws or perform maintenance. Thomson has solved this issue with our patented Taper-Lock coupling (D) that requires only a single retention fastener.

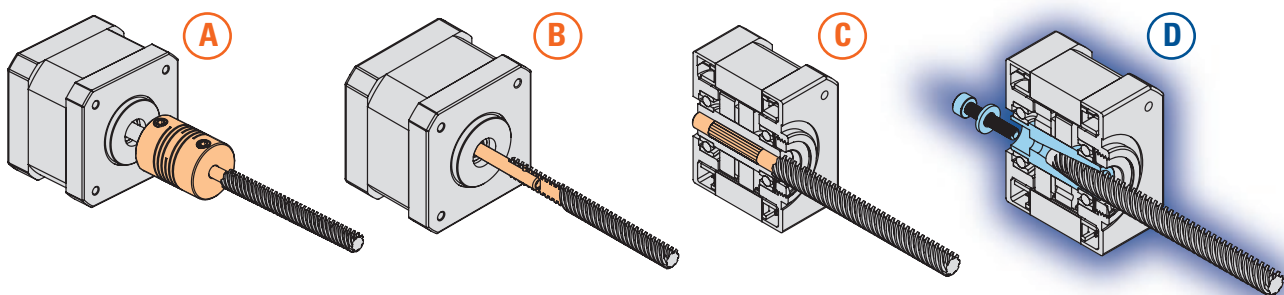

Coupling assembly

- space demanding
- requires more external components
- reduced stroke
- may reduce accuracy

Counter-bore press fit

- poor lead screw alignment
- lead screw prone to slipping and decoupling
- reduced stroke
- difficult to service lead screw

Hollow shaft press fit

- fewer compatible lead screws
- poor lead screw alignment
- lead screw prone to slipping and decoupling
- difficult to service lead screw

Thomson Taper-Lock

- increased lead screw configurability
- precise lead screw alignment
- increased stroke length
- compact form factor

Thrust Force Comparison

Thomson optimized motors will result in up to a 30% increase in thrust over the competition. That means you will get a smaller and more efficient solution with the same power output.

Temperature Rise Comparison

Thomson offers more efficient motors where more torque can be output with less heat loss – meaning that our motors can be operated with higher power input while maintaining lower heat generation.

Load vs. Speed

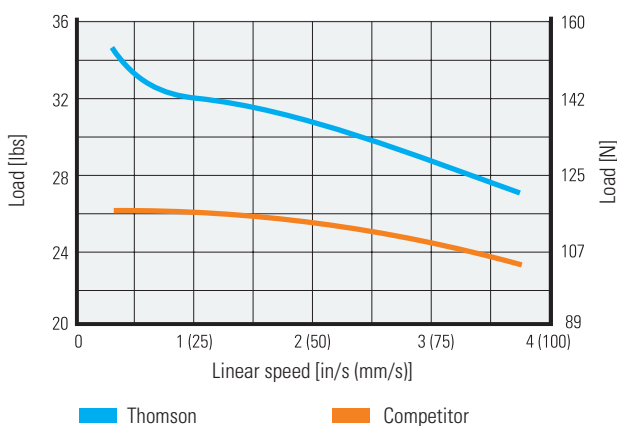

Temperature vs. Operation Time

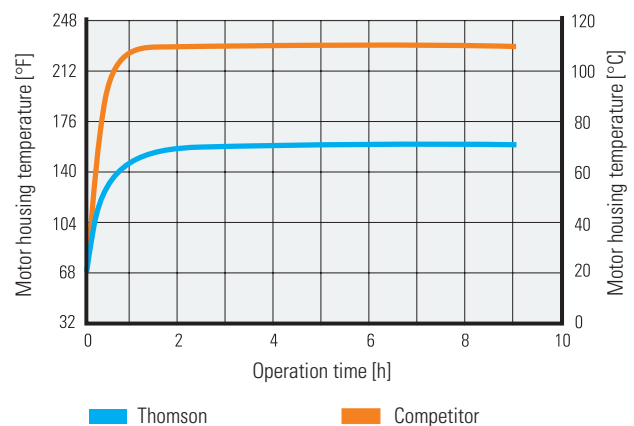

The curves were generated with a 1.5 A / 2.33 V, 1.8° NEMA 17 single stack, rotating screw stepper motor. Test ran with a 0.9°, 24 VDC chopper drive and a 4-2516 lead screw at an ambient temperature of 20 °C.



Application Examples

These common applications show that stepper motor linear actuators reduce the total number of components in your design, while minimizing space requirements, and making assembly and maintenance quicker and easier. Examples are shown for all three configurations - rotating screw (MLS), rotating nut (MLN) and actuator (MLA).

Pipetting MLA MLS

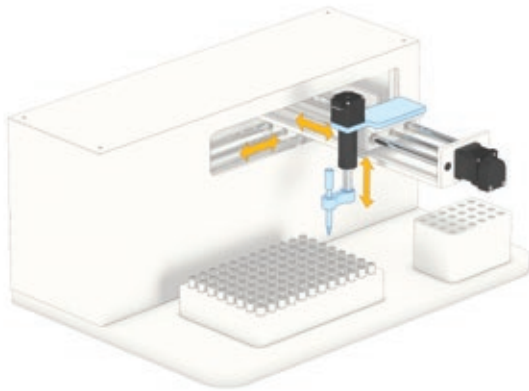

Tiny, precise, repeatable vertical motion is essential for accurate pipetting. Choose MLA to simplify your z-axis and MLS for precise, horizontal motion in pipetting applications.

Fluid Pumps MLN MLS



Regardless of the mounting configuration, a stepper motor linear actuator can increase pump pressure, reduce equipment footprint and more accurately dispense fluid.

Plate Vertical Positioning MLA

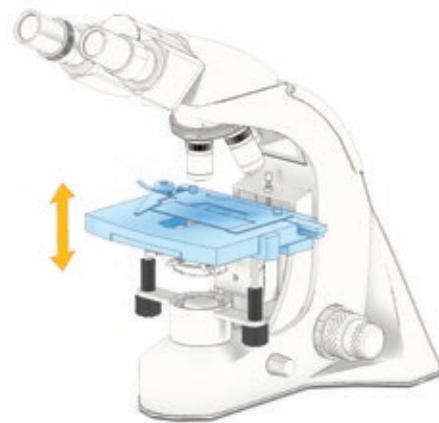

Actuator assemblies are self contained and ideal for simplified, leveling applications where small radial or moment loads may be present.

XY Stages MLS

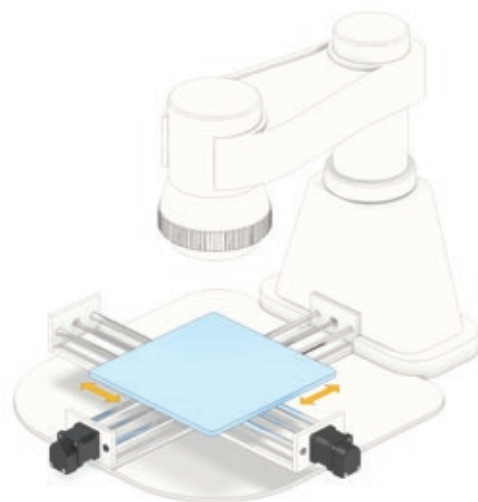

Stepper motor linear actuators optimize XY stage designs with their compactness and power.

Horizontal Positioning MLN

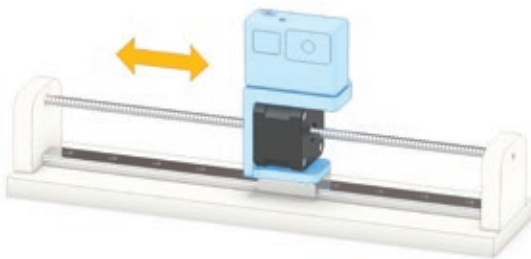

Cameras and other measurement devices need to be in just the right place at just the right time. MLN delivers reliable horizontal positioning and length selections to get your horizontal positioning job done right.

3D Printing MLS

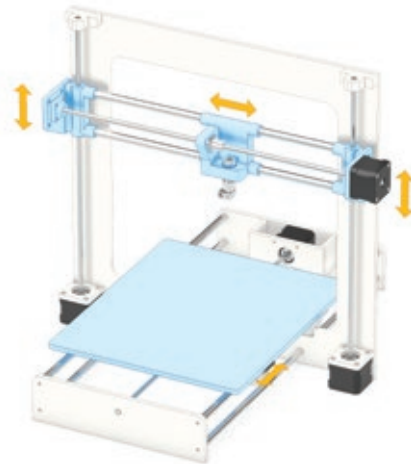

Utilizing a stepper motor linear actuator on a 3D printer can eliminate the need for couplings, bearings and supports while increasing stroke length and print volume.

Robotic Gripper MLN

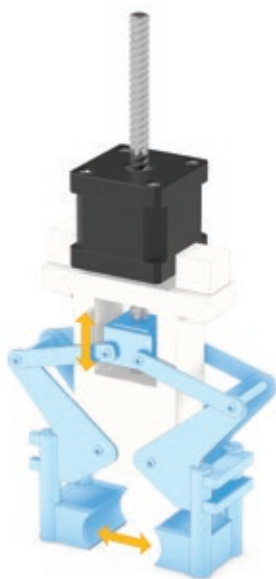

MLN configurations excel in gripping applications, rotating and positioning gripper heads and attachments with ease.

www.thomsonlinear.com

Monitor Tilting MLA

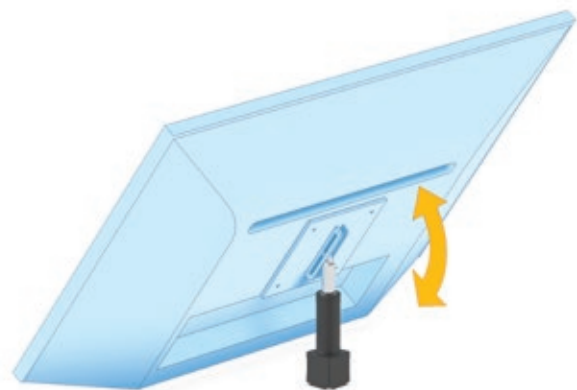

Angle adjustment is made simple when the MLA configuration is applied in monitor and plate tilting applications.



Ordering Keys

MLS/MLN Ordering Key																
1	2	3	4	5	6	7	8	9	10	11	12	13	14			
MLS	17	A	15	-	25	0250	P	06000	N	-	B2	00	-	RS	2	
1. Series MLS = Rotating screw MLN = Rotating nut				6. Linear travel/rev³ 0031 = 0.031 in 0750 = 0.750 in 0040 = 0.040 in 0800 = 0.800 in 0050 = 0.050 in 1000 = 1.000 in 0063 = 0.063 in 1200 = 1.200 in 0079 = 0.079 in 1500 = 1.500 in 0083 = 0.083 in 010 = 1.0 mm 0100 = 0.100 in 020 = 2.0 mm 0118 = 0.118 in 030 = 3.0 mm 0125 = 0.125 in 040 = 4.0 mm 0157 = 0.157 in 050 = 5.0 mm 0167 = 0.167 in 060 = 6.0 mm 0192 = 0.192 in 080 = 8.0 mm 0200 = 0.200 in 100 = 10.0 mm 0250 = 0.250 in 120 = 12.0 mm 0300 = 0.300 in 150 = 15.0 mm 0333 = 0.333 in 160 = 16.0 mm 0375 = 0.375 in 180 = 18.0 mm 0400 = 0.400 in 200 = 20.0 mm 0500 = 0.500 in 250 = 25.0 mm				10. Front-end machining⁵ A0 = No machining Plain journal ends: B1 = Ø 2.50 mm h7 B2 = Ø 4.00 mm h7 B3 = Ø 5.00 mm h7 B4 = Ø 6.00 mm h7 BX = Custom journal end machining ² Male threaded ends: C1 = #4-40 x 0.250 in C2 = #8-32 x 0.250 in C3 = #10-24 x 0.375 in C4 = 1/4-20 x 0.500 in C5 = M2.5x0.45 x 6.35 mm C6 = M4x0.7 x 6.35 mm C7 = M5x0.8 x 9.53 mm C8 = M6x1.0 x 12.70 mm CX = Custom threaded end ¹ Journal with snap ring groove: D1 = Ø 2.50 mm and ring groove D2 = Ø 4.00 mm and ring groove D3 = Ø 5.00 mm and ring groove D4 = Ø 6.00 mm and ring groove DX = Custom journal with snap ring groove ¹								
2. Motor size¹ 08 = NEMA 08 motor used through April 2022 (MLS only) X8 = NEMA 08 motor used after April 2022 (MLS only) 11 = NEMA 11 14 = NEMA 14 17 = NEMA 17 23 = NEMA 23				7. Accuracy grade S = Standard 0.010 in/ft (250 µm/300 mm) P = Precision 0.003 in/ft (75 µm/300 mm)				11. Rear-end machining⁵ MLN same options as front-end MLS is always 00 XX = Other custom end machining ²								
3. Motor stack¹ A = Single B = Double X = Custom single ² Y = Custom double ²				8. Lead screw overall length^{1,2} 0X000 = X.000 in (ex: 06000 = 6.000 in) XXX00 = XXX.00 mm (when metric diameter is selected, ex: 15000 = 150.00 mm)				12. Nut. MLN is always XX⁶ XX = No nut or MLN RS = Flange mount, acetal material (RSF Series nuts) AF = Flange mount, alternative anti-backlash (AFT Series nuts) BN = Threaded mount, bronze material (BN Series nuts) MT = Flange mount, alternative to RS nut (MTS Series nuts) RH = Flange mount, peek material (RSFH Series nuts) SB = Thread mount, alternative anti-backlash (SNAB Series nuts) SN = Threaded mount, acetal material (SN Series nuts) XF = Triangular flange, anti-backlash (XC Series nuts) XT = Threaded mount, anti-backlash (XC Series nuts)								
4. Motor current rating (in 0.1 amps)¹ 05 = 0.5 amps 08 = 0.8 amps 10 = 1.0 amps 13 = 1.3 amps 15 = 1.5 amps 19 = 1.9 amps 30 = 3.0 amps 39 = 3.9 amps				9. Lead screw coating N = No coating on lead screw T = PTFE-coated lead screw ⁴				13. Nut size. MLN is always X⁶ X = No nut or MLN 1 = 0.188 in and 4 mm dia screws ⁷ 2 = 0.250 in and 6 mm dia screws ^{8,9} 3 = 0.313 in, 0.375 in, 8 and 10 mm screws 5 = 0.438 in, 0.50 in and 12 mm screws								
5. Screw diameter³ 18 = 0.188 in M04 = 4.0 mm 25 = 0.250 in M06 = 6.0 mm 31 = 0.313 in M08 = 8.0 mm 37 = 0.375 in M10 = 10.0 mm 43 = 0.438 in M12 = 12.0 mm 50 = 0.500 in				14. Custom designation² (blank) = Standard configuration 001-999 = Custom configuration												

- For available standard motors, see pages 17-32.
- To be assigned by Thomson only.
- For compatible lead screws, see pages 12-13.
- PTFE coating not available for MLN configurations or with RH (RSFH) lead nuts.
- For compatible end-machining options, see page 15.
- RS nut standard on MLS. For optional nut compatibility, see pages 36-37.
- XF1 and XT1 nut also compatible for 0.250 in and 6 mm diameter lead screws
- SN2 nut used for 0.188 in diameter lead screws and SB2 nut used for 0.188 in and 4 mm diameter lead screws
- MT2 nut used for 0.188 in, 4 mm, 0.250 in, 6 mm, 0.313 in, and 8 mm diameter lead screws

MLS Example:

MLS11A05-180100S04000T-A000-RS1

MLS = Rotating screw (S) configuration
 11A05 = NEMA 11 (11), single stack (A), 0.51 amp (05) motor
 180100S04000T = 0.1875 in (18) diameter x 0.100 in (0100) lead screw, standard grade accuracy (S) at 4.000 in overall length (04000) with PTFE screw coating (T)
 A000 = No (A0) and MLS default N/A (00) end-machining on screw
 RS1 = RSF1800 lead nut

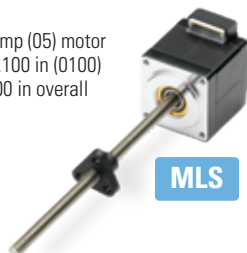

MLN Example:

MLN17B15-M06120P15000N-A0C6-XXX

MLN = Rotating nut (N) configuration
 17B15 = NEMA 17 (17), double stack (B), 1.50 amp (15) motor
 M06120P15000N = 6 mm (M06) diameter x 12.0 mm (120) lead screw, precision grade accuracy (P) at 150 mm overall length (15000) with no screw coating (N)
 A0C6 = No (A0) and M4x0.7 threaded end x 6.35 mm length (C6) end-machining on screw
 XXX = no nut (required for MLN / rotating nut assemblies)

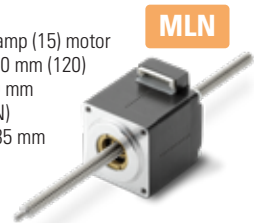

Please visit thomsonlinear.com/smla to access our stepper motor linear actuator selector and part number generator.

MLA Ordering Key											
1	2	3	4	5	6	7	8	9	10		
MLA	17	A	15	–	0250	P	0150	–	C5	–	S02
1. Series MLA = Motorized lead screw actuator			5. Linear travel/rev (lead in 0.001 inch)³ 0031 = 0.031 in 0236 = 0.236 in (6 mm) 0039 = 0.039 in (1 mm) 0250 = 0.250 in 0040 = 0.040 in 0300 = 0.300 in 0050 = 0.050 in 0315 = 0.315 in (8 mm) 0063 = 0.063 in 0333 = 0.333 in 0079 = 0.079 in (2 mm) 0375 = 0.375 in 0083 = 0.083 in 0394 = 0.394 in (10 mm) 0100 = 0.100 in 0400 = 0.400 in 0118 = 0.118 in (3 mm) 0472 = 0.472 in (12 mm) 0125 = 0.125 in 0500 = 0.500 in 0157 = 0.157 in (4 mm) 0709 = 0.709 in (18 mm) 0167 = 0.167 in 0750 = 0.750 in 0192 = 0.192 in 0787 = 0.787 in (20 mm) 0197 = 0.197 in (5 mm) 1000 = 1.000 in 0200 = 0.200 in 1200 = 1.200 in			8. End-mounting⁴ ML08: C1 = #4-40 x 0.236 in male E1 = #4-40 x 0.236 in female C4 = M3x0.5 x 5.99 mm male E4 = M3x0.5 x 5.99 mm female ML1x: C2 = #8-32 x 0.265 in male E2 = #8-32 x 0.265 in female C5 = M4x0.7 x 6.73 mm male E5 = M4x0.7 x 6.73 mm female ML23: C3 = 1/4-20 x 0.500 in male E3 = 1/4-20 x 0.500 in female C6 = M6x1.0 x 12.70 mm male E6 = M6x1.0 x 12.70 mm female					
2. Motor size¹ 08 = NEMA 08 motor used through April 2022 X8 = NEMA 08 motor used after April 2022 11 = NEMA 11 14 = NEMA 14 17 = NEMA 17 23 = NEMA 23			6. Accuracy Grade S = Standard 0.010 in/ft (250 µm/300 mm) P = Precision 0.003 in/ft (75 µm/300 mm)			9. Nut S01 = For ML08 S02 = For ML1x S03 = For ML23					
3. Motor stack¹ A = Single B = Double X = Custom single ² Y = Custom double ²			7. Stroke length (in 0.01 inch) QXXX = X.XX in stroke length (always in inch) (ex: 0150 = 1.50 in stroke. Max stroke length = 1.50 in for MLA08 and 2.50 in for all others)			10. Custom designation² (blank) = Standard configuration 001-999 = Custom configuration					
4. Motor Current Rating (in 0.1 amps)¹ 05 = 0.5 amps 08 = 0.8 amps 10 = 1.0 amps 13 = 1.3 amps 15 = 1.5 amps 19 = 1.9 amps 30 = 3.0 amps 39 = 3.9 amps											
1. For available standard motors, see pages 17-32. 2. To be assigned by Thomson only. 3. For compatible linear travel/rev, see pages 12-13. 4. For more details on mounting options, see page 16.											

MLA Example:

MLA14A08-0472S0175-E5-S02

MLA = Actuator (A) configuration

14A08 = NEMA 14 (14), single stack (A), 0.88 amp (08) motor

0472S0175 = 0.472 in lead (0472), standard grade accuracy (S) at 1.75 in stroke (0175)

E5 = Standard M4x0.7 female threaded end

S02 = Standard nut for size 11, 14, and 17 configurations

Please visit www.thomsonlinear.com/smla to access our stepper motor linear actuator selector and part number generator.

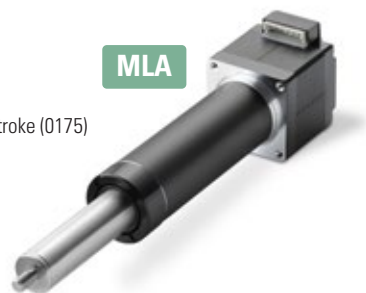



Sizing and Selection Guidelines

How to Select Motor and Lead Screw

For a basic sizing determination, use the motor performance charts throughout the brochure to select the appropriate lead screw based on your load and speed requirements.

Example:

Required Force = 20 lbf (89 N)

Required Speed = 1 in/s (25 mm/s)

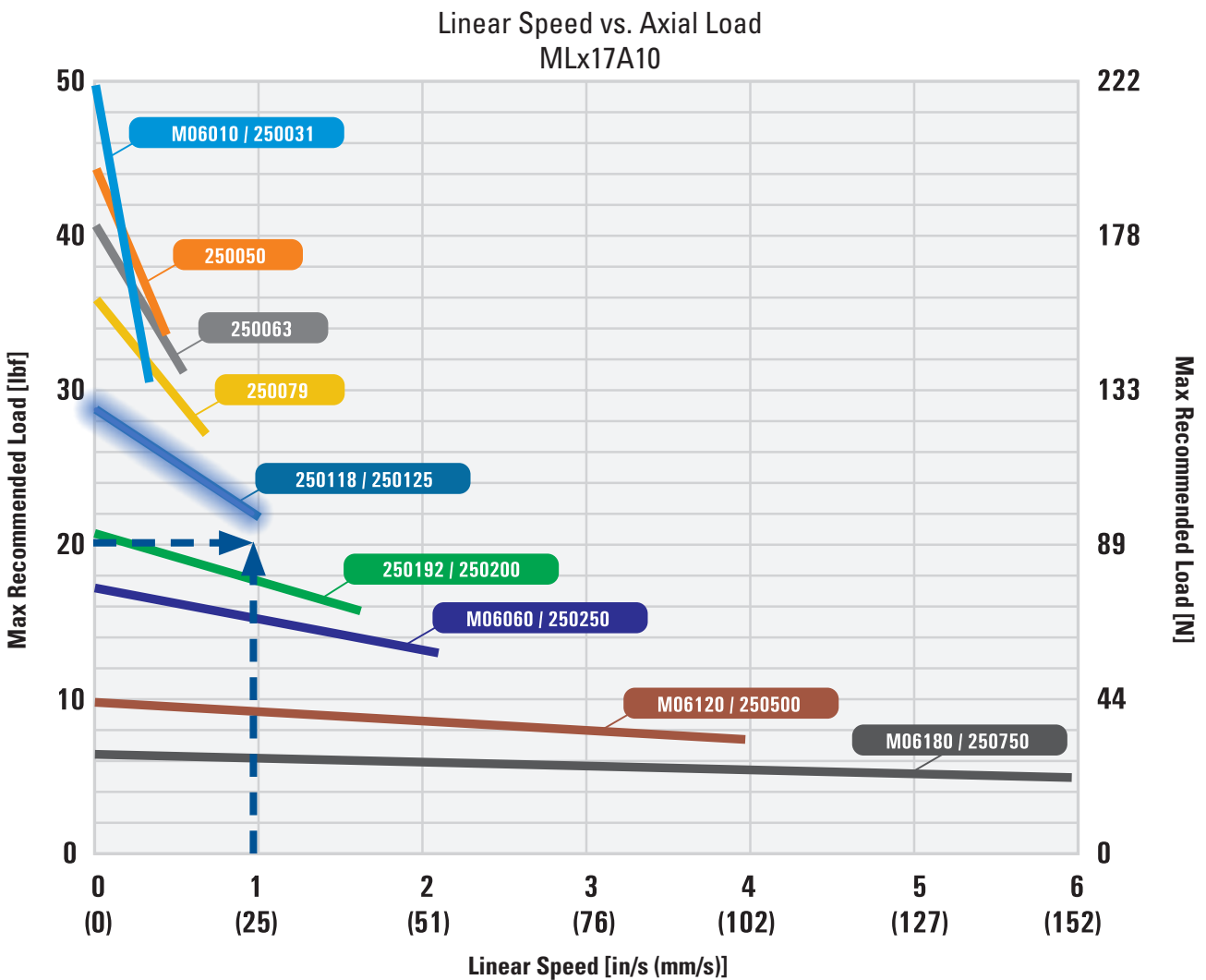

Given the force and speed requirements of 20 lbf and 1 in/s, respectively, the ideal screw is a 250118 or 250125 with this motor.

Note: Simplified performance diagrams are theoretical only and assume ideal conditions with a 24 VDC power supply, standard material lead nut and a moderate length, non-lubricated lead screw. Higher loads and speeds can be achieved. For more detailed performance plots and sizing tools, please visit www.thomsonlinear.com/en/products/motorized-lead-screws.

Sizing and Selection Guidelines

How to Determine Maximum Permissible Screw Length

For MLS and MLN configurations, in order to determine the maximum possible lead screw length for your stepper motor linear actuator assembly, the following charts can be used. These charts take in to consideration the maximum rotational speed and compression load as well as the end fixity of your system.

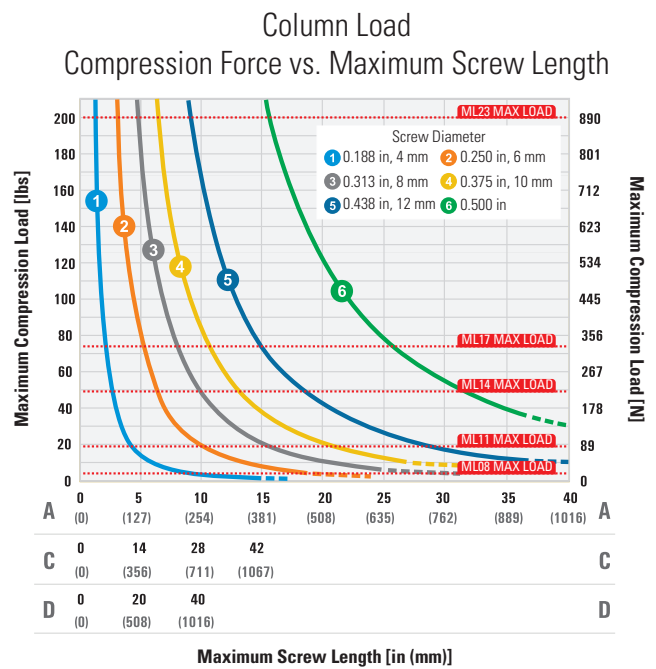
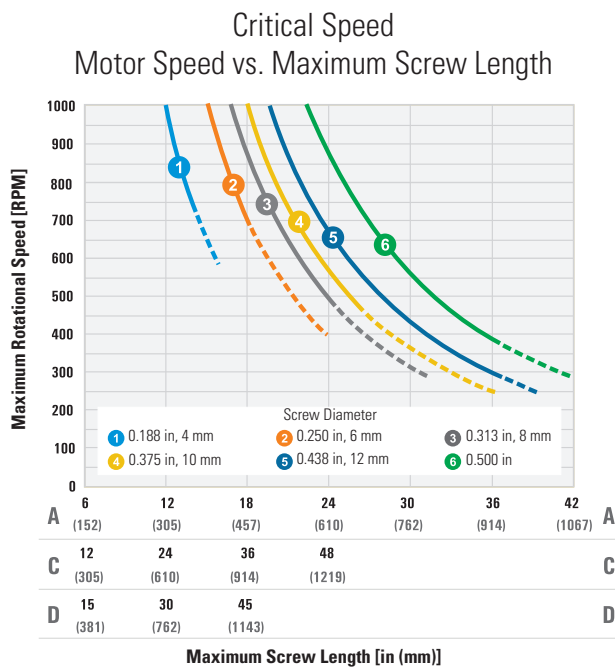

Types of Screw End Fixity

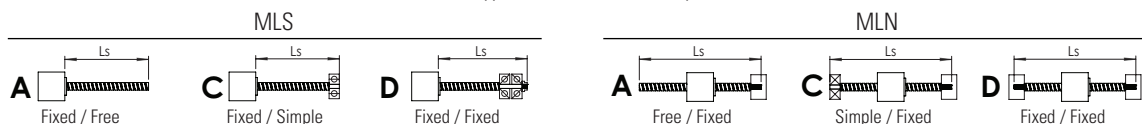

1. Determine Maximum Motor Speed

Calculate what the maximum motor speed will be for your specific application.

2. Decide Type of Screw End Fixity

There are three basic types of end fixity (A, C and D). The maximum screw length (L_s) for a given motor speed, unit size and screw diameter will vary depending on the selection. For rotating screw assemblies, the end of the lead screw attached to the motor is considered fixed.

3. Check Critical Screw Speed

Check Critical Speed diagram for your maximum speed, lead screw diameter and end fixity to determine the maximum permissible screw length for your application.

4. Check Column Loading

Another limiting factor for the screw length is how sensitive it is to column loading and how likely it is to buckle under a compression load. Check the Column Load diagram to see that your load and desired maximum screw length are compatible with regards to the unit size, lead screw diameter and end fixity being used.



Lead Screw Sizes

Inch Lead Screws			S = Rotating Screw (MLS), N = Rotating Nut (MLN), A = Actuator (MLA)									
Linear Travel / Full Step [μ in.]	Lead [in.]	Lead Designator	Motor									
			MLx08, MLx8		MLx11		MLx14, MLx17			MLx23		
			Diameter Designator [hundredths of in. diameter]									
			18	18	25	25	31	37	31	37	43	50
0.063 ²	0.013	0013			S,A ^{1,3}	S,N,A ^{1,3}	S ^{1,3}	S ^{1,3}	S,N ^{1,3}	S,N,A ^{1,3}		S ^{1,3}
0.125 ²	0.025	0025			S,A ^{1,3}	S,N,A ^{1,3}		S ¹		S,N,A ¹		S ^{1,3}
0.157 ²	0.031	0031			S,A	S,N,A		S ¹		S,N,A ¹		
0.165 ²	0.033	0033										S ^{1,3}
0.179 ²	0.036	0036			S,A ^{1,3}	S,N,A ^{1,3}						
0.200 ²	0.040	0040						S ¹		S,N,A ¹		
0.209 ²	0.042	0042			S,A ^{1,3}	S,N,A ^{1,3}	S ^{1,3}	S ^{1,3}	S,N ^{1,3}	S,N,A ^{1,3}		
0.250 ²	0.050	0050	S,A	S,N	S,A ¹	S,N,A ¹		S ¹		S,N,A ¹	S ^{1,3}	S ^{1,3}
0.313 ²	0.063	0063			S,A	S,N,A		S		S,N,A		S ¹
0.394	0.079 ⁴	0079			S,A ¹	S,N,A ¹		S ¹		S,N,A ¹		
0.417 ²	0.083	0083					S	S ¹	S,N	S,N,A ¹		
0.500	0.100	0100	S,A	S,N				S		S,N,A		S ¹
0.591	0.118 ⁴	0118			S,A ¹	S,N,A ¹						
0.625	0.125	0125	S,A ¹	S,N ¹	S,A	S,N,A		S ¹		S,N,A ¹	S ¹	
0.787	0.157 ⁴	0157			S,A ¹	S,N,A ¹						
0.833	0.167	0167					S	S	S,N	S,N,A		
0.960	0.192	0192			S,A ¹	S,N,A ¹						
1.000	0.200	0200	S,A	S,N	S,A ¹	S,N,A ¹		S ¹		S,N,A ¹		S ¹
1.250	0.250	0250			S,A	S,N,A	S	S	S,N	S,N,A	S ¹	S ¹
1.500	0.300	0300						S ¹		S,N,A ¹		
1.665	0.333	0333	S,A ^{1,3}	S,N ^{1,3}								
1.875	0.375	0375	S,A ^{1,3}	S,N ^{1,3}				S ¹		S,N,A ¹		
2.000	0.400	0400	S,A	S,N								
2.500	0.500	0500	S,A ^{1,3}	S ^{1,3}	S,A	S,N,A	S	S	S,N	S,N,A	S ¹	S ¹
3.750	0.750	0750			S,A ^{1,3}	S,N,A ^{1,3}		S ^{1,3}		S,N,A ^{1,3}		
4.000	0.800	0800										S ^{1,3}
5.000	1.000	1000					S ³	S ³	S,N ³	S,N,A ³		S ^{1,3}
6.000	1.200	1200						S ^{1,3}		S,N,A ^{1,3}		
7.500	1.500	1500										S ^{1,3}

1. Some leads may not be available in high-performance nut material or some anti-backlash nuts. Contact Thomson for more detail.
2. Fine-pitched lead screws may have substantially lower load capacities compared to traditional lead screws.
3. Lead screw not available in precision grade accuracy (P).
4. Hybrid threadform consisting of diameter in [in] and lead in [mm] (example: 0.25 in x 2 mm).

Note: Not all available lead screws are shown above. Please contact Thomson for more details.

Metric Lead Screws			S = Rotating Screw (MLS), N = Rotating Nut (MLN), A = Actuator (MLA)									
Linear Travel / Full Step [μm]	Lead [mm]	Lead Designator ²	Motor									
			MLx08, MLx8		MLx11		MLx14, ML17			MLx23		
			Diameter Designator									
			M04	M04	M06	M06	M08	M10	M08	M10	M12	
5	1.0	010 (0039)	S, A	S,N	S,A	S,N,A						
10	2.0	020 (0079)					S	S	S,N	S,N,A	S ¹	
15	3.0	030 (0118)						S		S,N,A	S ¹	
20	4.0	040 (0157)	S, A	S,N			S		S,N		S ¹	
25	5.0	050 (0197)						S		S,N,A		
30	6.0	060 (0236)			S,A	S,N,A		S ¹		S,N,A ¹	S ¹	
40	8.0	080 (0315)	S, A ³	S,N ³			S		S,N			
50	10.0	100 (0394)						S		S,N,A	S ¹	
60	12.0	120 (0472)			S,A	S,N,A	S	S ¹	S,N	S,N,A ¹		
75	15.0	150 (0591)										S ¹
80	16.0	160 (0630)										S ¹
90	18.0	180 (0709)			S,A ^{1,3}	S,N,A ^{1,3}						
100	20.0	200 (0787)					S ³	S	S,N ³	S,N,A		
125	25.0	250 (0984)										S ^{1,3}

1. Some leads may not be available in high-performance nut material or some anti-backlash nuts. Contact Thomson for more detail.

2. Lead designations for MLA are shown in parenthesis.

3. Lead screw not available in precision grade accuracy (P).

Note: Not all available lead screws are shown above. Please contact Thomson for more details.



Specifications

Basic Specifications						
Lead Screw						
Material	300 Series Stainless Steel					
Standard Coating ¹	None					
Standard Lead Accuracy	[in./ft. (µm/300 mm)]	0.010 (250)				
Precision Lead Accuracy	[in./ft. (µm/300 mm)]	0.003 (75)				
Straightness	[in./ft. (µm/300 mm)]	0.005 (125)				
Lead Nut						
Standard Material	Internally lubricated acetal (POM)					
High Performance Material	Internally lubricated PEEK					
Nut Efficiency ²	[%]	Up to 85				
Typical Linear Travel Life	[in. (km)]	5 × 10 ⁶ (125)				
Positional Repeatability with Standard Nut ³	[in. (mm)]	0.005 to 0.010 (0.127 to 0.254)				
Positional Repeatability with Anti-Backlash Nut ⁴	[in. (mm)]	<0.002 (0.051)				
Motor						
Frame Size		NEMA 8	NEMA 11	NEMA 14	NEMA 17	NEMA 23
Step Size	[°]	1.8	1.8	1.8	1.8	1.8
Max. Axial Load ⁵	[lbs. (N)]	5 (22)	20 (89)	50 (222)	75 (334)	200 (890)
Axial Pre-Load ⁶	[lbs. (N)]	5 (22)	20 (89)	30 (133)	40 (178)	40 (178)
Concentricity of Mounting Pilot to Shaft	[in. (mm)]	0.003 (0.08) TIR				
Perpendicularity of Shaft to Mounting Face	[in. (mm)]	0.003 (0.08) TIR				
Max. Case Temperature	[°F (°C)]	140 (60)		176 (80)		
Storage Temperature	[°F (°C)]	-4 to 122 (-20 to 50)				
Ambient Temperature	[°F (°C)]	-4 to 122 (-20 to 50)				
Max. Humidity (non-condensing)	[%]	85				
Magnet Wire Insulation		Class B 130 °C (266 °F)				
Insulation Resistance		100 Mohm @ 500 VDC				
Dielectric Strength		500 VAC for 1 minute				
Assembly						
Max. Backlash with Standard Nut ⁷	[in. (mm)]	0.010 (0.25)				
Max. Backlash with XC Anti-Backlash Nut	[in. (mm)]	0 (0)				
Max Lead Screw Runout ⁸	[in. (mm)]	0.010 (250)				
Operating Temperature	[°F (°C)]	15 to 125 (-10 to 50)				
MLA Max Side Load ⁹	[% of axial load]	10				
MLA Extension Tube Max Total Rotational Play	[+/- degrees]	3				

- Contact Thomson for optional lead screw coatings.
- Depending on lead, nut material and lubrication.
- Depends on nut, load and orientation.
- For best positional repeatability, load should be kept well below design load of nut.
- Max. axial load based on a L10 life of 10000 hours of continuous motion at speeds of 100 to 300 RPM.
- Can be adjusted based on application requirements. If axial load exceeds pre-load of motor, motor shaft may deflect up to 0.003 in. (0.08 mm) for configurations with axial load pulling away from motor face.
- Nut fit can be adjusted depending on backlash requirements.
- Max radial load on MLA assemblies depends on load orientation, speed, stroke and other factors. For optimal performance, side loads should be avoided at end of travel. Contact Thomson for application assistance.
- Assemblies with lead screws exceeding max recommended length may have a higher runout.

Lead Screw Standard End Machining MLS MLN

A0

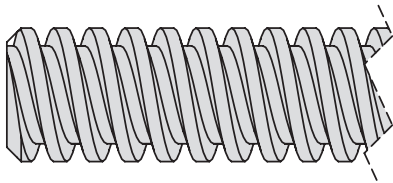

B Type

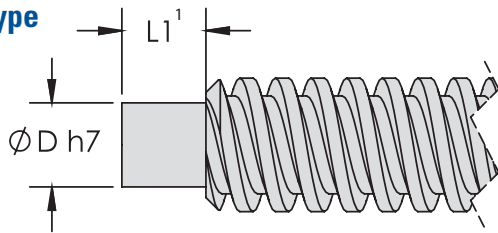

C Type

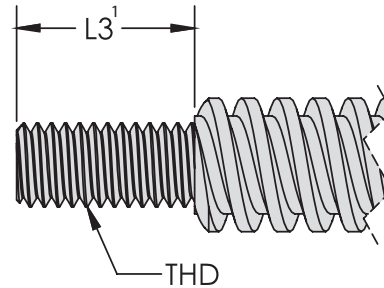

MACH.	in		mm		Compatible Lead Screws
	ØD	L1	ØD	L1	
B1	0.0984	0.098	2.50	2.50	0.188 in, 4 mm, 0.25 in, 6 mm, 0.313 in, 8 mm, 0.375 in, 10 mm
B2	0.1575	0.197	4.00	5.00	0.25 in, 6 mm, 0.313 in, 8 mm, 0.375 in, 10 mm
B3	0.1969	0.197	5.00	5.00	0.313 in, 8 mm, 0.375 in, 10 mm
B4	0.2362	0.236	6.00	6.00	0.375 in, 10 mm

MACH.	in		MACH.	mm		Compatible Lead Screws
	THD	L3		THD	L3	
C1	#4-40	0.250	C5	M2.5X0.45	6.35	0.188 in, 4 mm, 0.25 in, 6 mm, 0.313 in, 8 mm, 0.375 in, 10 mm
C2	#8-32	0.250	C6	M4X0.7	6.35	0.25 in, 6 mm, 0.313 in, 8 mm, 0.375 in, 10 mm
C3	#10-24	0.375	C7	M5X0.8	9.53	0.313 in, 8 mm, 0.375 in, 10 mm
C4	1/4-20	0.500	C8	M6X1.0	12.70	0.375 in, 10 mm

D Type

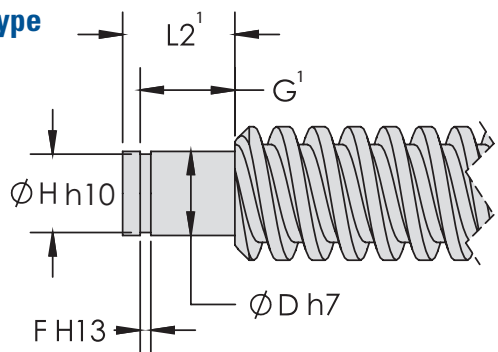

MACH.	in				mm						Compatible Lead Screws
	ØD	L2	G	F	ØH	ØD	L2	G	F	ØH	
D1	0.0984	0.157	0.120	0.022	0.075	2.50	4.00	3.05	0.56	1.91	0.188 in, 4 mm, 0.25 in, 6 mm, 0.313 in, 8 mm, 0.375 in, 10 mm
D2	0.1575	0.256	0.217	0.020	0.150	4.00	6.50	5.51	0.51	3.81	0.25 in, 6 mm, 0.313 in, 8 mm, 0.375 in, 10 mm
D3	0.1969	0.276	0.224	0.028	0.189	5.00	7.00	5.69	0.70	4.80	0.313 in, 8 mm, 0.375 in, 10 mm
D4	0.2362	0.315	0.266	0.030	0.220	6.00	8.00	6.76	0.76	5.59	0.375 in, 10 mm

1. Typical tolerance is +/- 0.005 in (+/- 0.13 mm)

Note: Machining is split into four different categories (A, B, C and D). Within each category are different sizes (X1, X2, X3,...). Please specify exact end machining when configuring part number. Above are examples of the standard end machining offered. Tolerances not specified are typically +/-0.005 in (+/-0.13 mm). Contact Thomson for custom end-machining options.



Standard End Mounting MLA

C Type

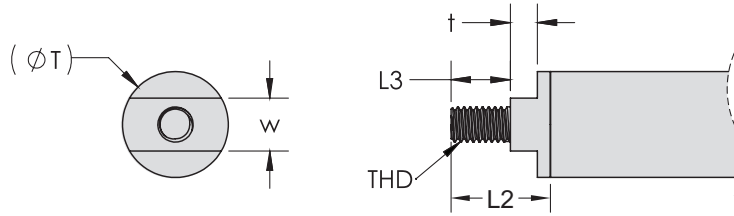

Motor Size	MACH.	in					
		THD	L2	L3	w	t	$\varnothing T$
MLA08, X8	C1	#4-40	0.380	0.236	0.197	0.105	0.354
MLA11, 14, 17	C2	#8-32	0.444	0.265	0.265	0.120	0.472
MLA23	C3	1/4-20	0.714	0.500	0.433	0.135	0.866

Motor Size	MACH.	mm					
		THD	L2	L3	w	t	$\varnothing T$
MLA08, X8	C4	M3X0.5	9.65	5.99	5.00	2.67	9.00
MLA11, 14, 17	C5	M4X0.7	11.28	6.73	6.73	3.05	12.00
MLA23	C6	M6X1.0	18.14	12.70	11.00	3.43	22.00

E Type

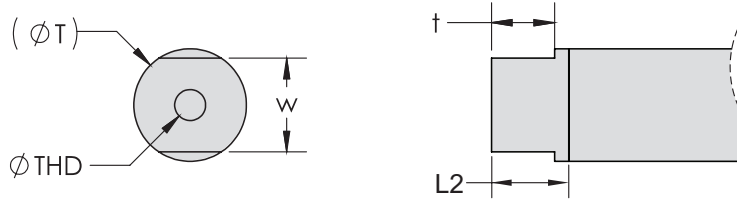

Motor Size	MACH.	in				
		THD	L2	w	t	$\varnothing T$
MLA08, X8	E1	#4-40 \downarrow 0.236	0.276	0.315	0.236	0.354
MLA11, 14, 17	E2	#8-32 \downarrow 0.265	0.324	0.394	0.265	0.472
MLA23	E3	1/4-20 \downarrow 0.500	0.579	0.709	0.500	0.866

Motor Size	MACH.	mm				
		THD	L2	w	t	$\varnothing T$
MLA08, X8	E4	M3X0.5 \downarrow 5.99	7.01	8.00	5.99	9.00
MLA11, 14, 17	E5	M4X0.7 \downarrow 6.73	8.23	10.01	6.73	12.00
MLA23	E6	M6X1.0 \downarrow 12.70	14.71	18.01	12.70	22.00

Note: When attaching load to end mounting, dimension "w" and "t" must be properly restrained in order to prevent damage to actuator. Contact Thomson for custom end-machining options.

Specifications – MLx08, MLxX8 Motor Size

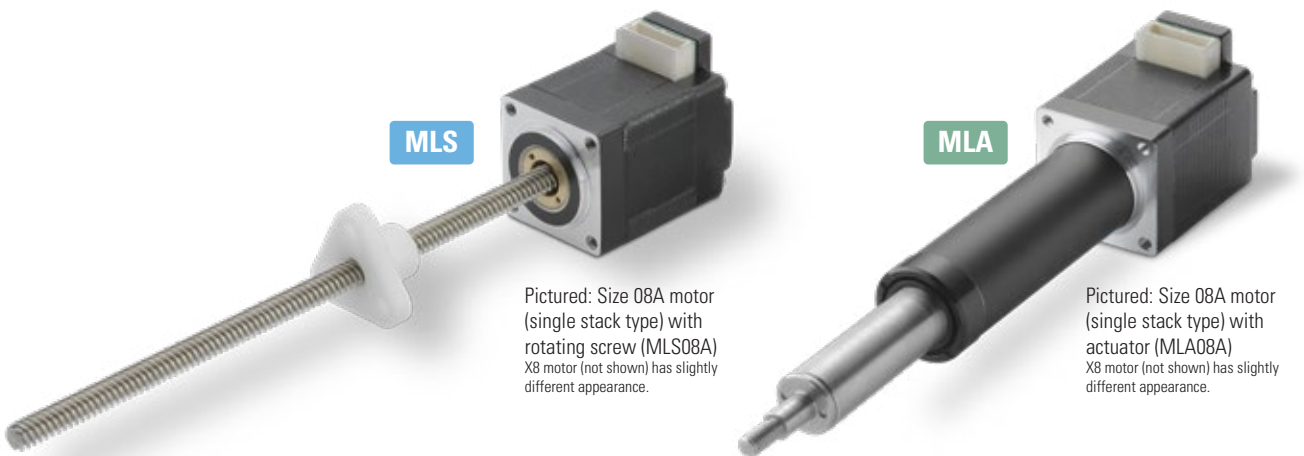

Features and Benefits

- NEMA 8 motor (size 21 mm)
- Available in rotating screw (MLS) and actuator (MLA) configurations
- Choose between a variety of inch and metric leads
- Recommended max. thrust force 5 lbs. (22 N). See performance plots for actual load limits
- Recommended max. lead screw length of 4 in. (102 mm) for MLS and 1.5 in. (38 mm) stroke for MLA.
- Side load capacity of up to 10% of axial load for MLA configurations.¹

Motor Options

Motor Code ²	Holding Torque		Voltage/phase ⁴	Current/phase ⁵	Resistance	Inductance	Power Draw	Step Angle	Motor Length, maximum (Lm)		Rotor Inertia	Motor Weight
	[oz-in]	[mN-m]	[V]	[A]	[Ω]	[mH]	[W]	[°]	[in]	[mm]	[oz-in ²]	[lbs]
MLx08A05 ³	2.2	16	4.5	0.50	9	2	2.3	1.8	1.16	29.5	0.01	0.13
MLxX8A05	2.83	20	3.9	0.50	7.7	2	1.9	1.8	1.16	29.5	0.01	0.13

Inch Lead Screw Options⁶

Diameter	Lead	Travel/step	Screw Code ⁷
[in.]	[in.]	[in.]	
0.188	0.050	0.00025	180050 (0050)
	0.100	0.00050	180100 (0100)
	0.200	0.00100	180200 (0200)
	0.400	0.00200	180400 (0400)

Metric Lead Screw Options⁶

Diameter	Lead	Travel/step	Screw Code ⁷
[mm]	[mm]	[mm]	
4	1	0.00500	M04010 (0039)
	4	0.02000	M04040 (0157)
	8	0.04000	M04080 (0315)

1. Maximum side load on MLA assemblies depends on load orientation, speed, stroke and other factors. For optimal performance, side loads should be avoided at end of travel. Contact Thomson for application assistance.

2. Contact Thomson for additional available motor windings.

3. "x" denotes placeholder for S or A depending upon configuration.

4. Applied voltage can be any value above this number as long as output current is controlled at the rated RMS current.

5. For optimal torque output, motor should be driven at 1.41 x RMS current listed above.

6. See lead screw selection matrix on pages 12-13 for other available lead screw configurations. Contact Thomson for more information about custom lead screw availability.

7. Codes within parentheses are for MLA configurations. Screw code utilized within the full assembly part number.



Dimensions – MLx08, MLxX8

MLS Configuration

Dimensions	Projection
Inch [mm]	

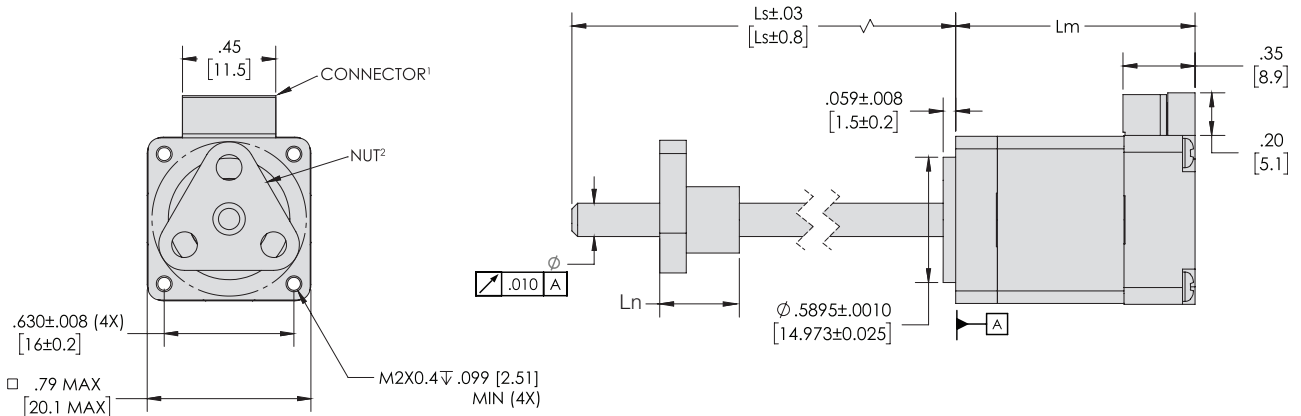

MLA Configuration

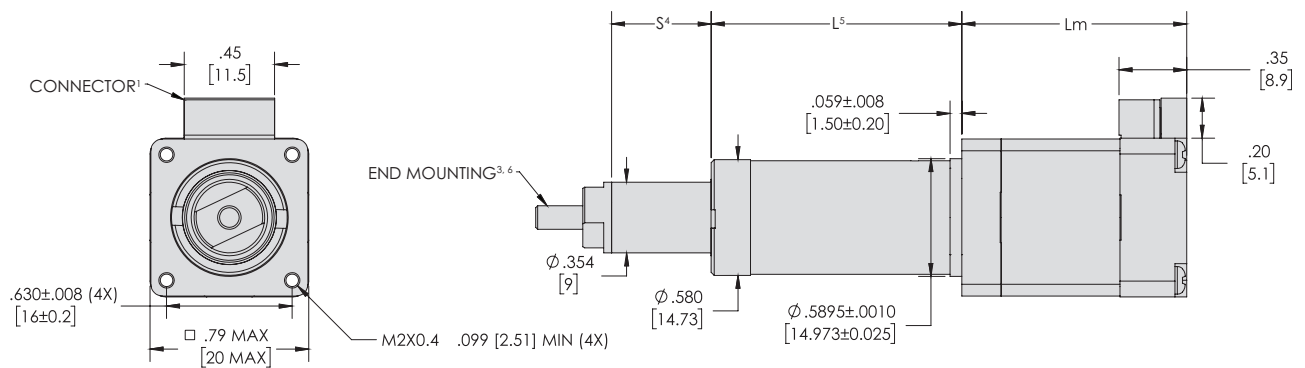

1. S6B-ZR(LF)(SN) connector shown. Wire harness with JST ZHR-6 mating connector and flying leads included with motor. For wiring diagram and connector details, see page 45.
2. RSF1800 (RS1) lead nut shown. For other nut options, see Nut Selection table on pages 36-37.
3. Standard M3x0.5 male end mounting (C4) shown. For other end mount options, see page 16.
4. Max stroke length for MLA08 configurations is 1.5 in. (38 mm). End of travel collisions should be avoided. Contact Thomson for additional stroke lengths.
5. Cover tube length (L) = stroke (S) + 0.76 in. (19.3 mm).
6. Extension tube total max rotational play = +/- 3 degrees. Fit can be modified. Contact Thomson for more details.

MLx08 – Performance Diagrams

MLx08A05

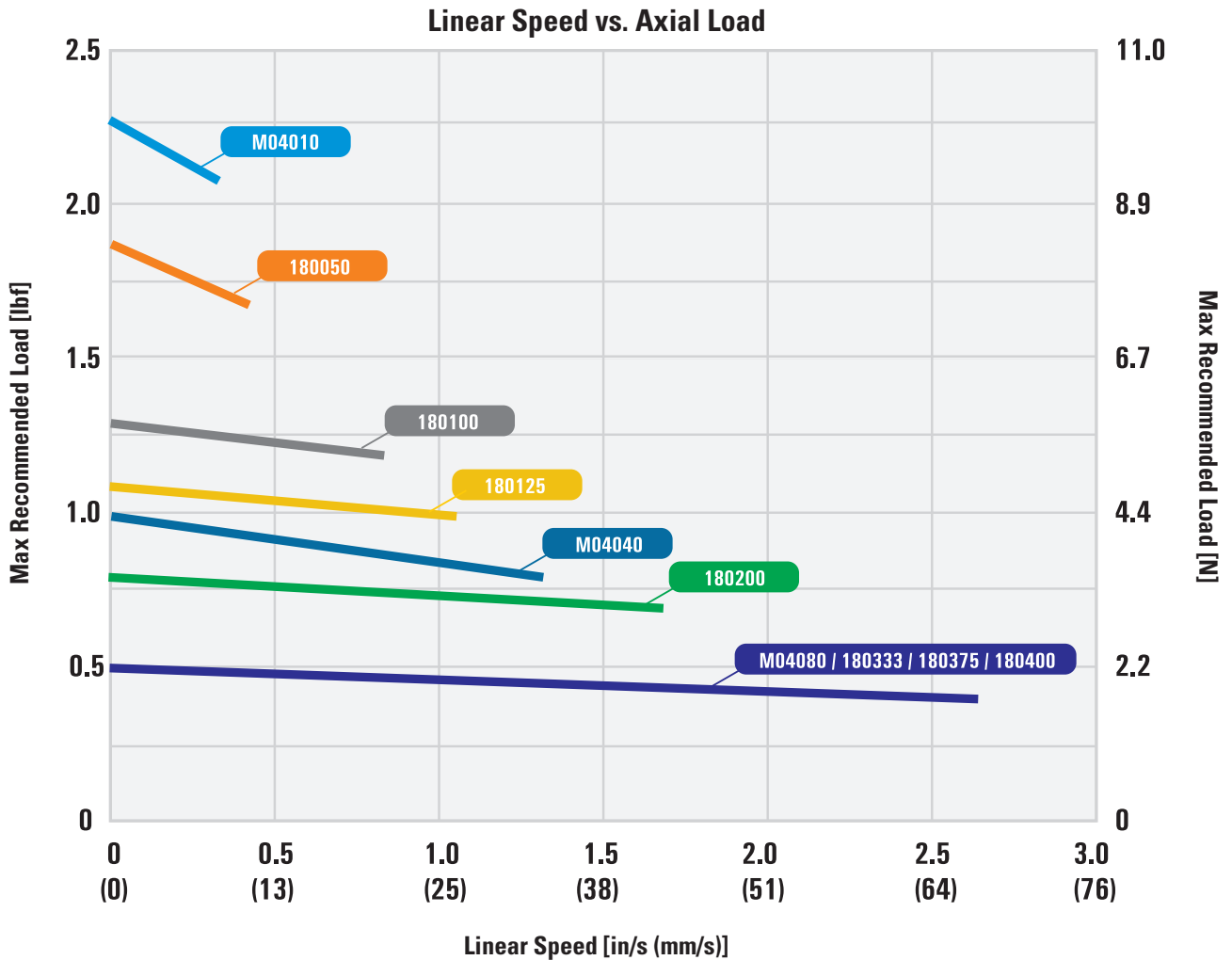

Note: Simplified performance diagrams are theoretical only and assume ideal conditions with a 24 VDC power supply, standard material lead nut and a moderate length, non-lubricated lead screw. Higher loads and speeds can be achieved. For more detailed performance plots and sizing tools, please visit www.thomsonlinear.com/en/products/motorized-lead-screws.



Specifications – MLx11 Motor Size



Features and Benefits

- NEMA 11 motor (size 28 mm).
- Choose between a variety of inch and metric lead screws
- Recommended max. thrust force 20 lbs. (89 N).
- Recommended max. lead screw length of 4 in. (102 mm) for MLS / MLN and 2.5 in. (64 mm) stroke for MLA.
- Side load capacity of up to 10% of axial load for MLA configurations.
- MLS and MLA configurations are encoder ready. See pages 40-41 for more details.

Motor Options

Motor code ¹	Holding torque		Voltage / phase ³ [V]	Current / phase ⁴ [A]	Resistance [Ω]	Inductance [mH]	Power draw [W]	Step angle [°]	Motor length, maximum (Lm)		Rotor inertia [oz-in ²]	Motor weight [lbs]
	[oz-in]	[N-m]							[in]	[mm]		
MLx11A05 ²	9.3	0.066	3.85	0.51	7.54	5.22	1.96	1.8	1.26	32.0	0.06	0.24
MLx11A10 ²	10.1	0.071	2.19	1.00	2.19	1.53	2.19	1.8	1.26	32.0	0.06	0.24

Inch Lead Screw Options⁵

Diameter [in.]	Lead [in]	Travel / step [in]	Screw code ⁶
0.188 ⁷	0.050	0.00025	180050
	0.100	0.00050	180100
	0.200	0.00100	180200
	0.400	0.00200	180400
0.250 ⁸	0.0313	0.00016	250031 (0031)
	0.0625	0.00031	250063 (0063)
	0.1250	0.00063	250125 (0125)
	0.2500	0.00125	250250 (0250)
	0.5000	0.00250	250500 (0500)
	0.7500	0.00375	250750 (0750)

Metric Lead Screw Options⁵

Diameter [mm]	Lead [mm]	Travel / step [mm]	Screw code ⁶
4 ⁷	1	0.00500	M04010
	4	0.02000	M04040
	8	0.04000	M04080
6 ⁸	1	0.00500	M06010 (0039)
	6	0.03000	M06060 (0236)
	12	0.06000	M06120 (0472)

1. Contact Thomson for additional available motor windings.
 2. "x" denotes placeholder for S, N or A depending upon configuration.
 3. Applied voltage can be any value above this number as long as output current is controlled at the rated RMS current.
 4. For optimal torque output, motor should be driven at 1.41 x RMS current listed above.

5. See lead screw selection matrix on pages 12-13 for additional lead screw configurations.
 6. Codes within parentheses are for MLA configurations. Screw code utilized within the full assembly part number
 7. Lead screw diameter not compatible with MLA configurations.
 8. Lead screw diameter not compatible with MLN configurations.

Dimensions – MLx11

MLS Configuration

Dimensions	Projection
Inch [mm]	

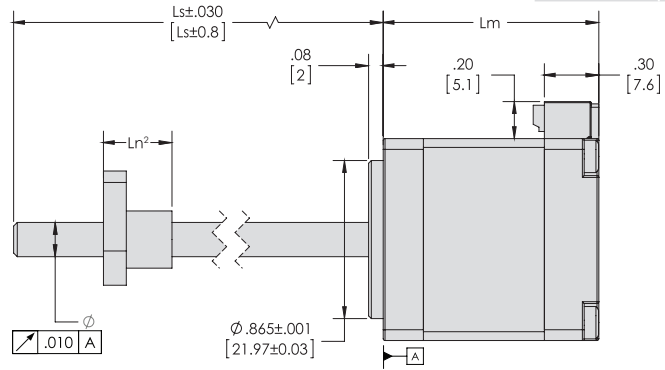
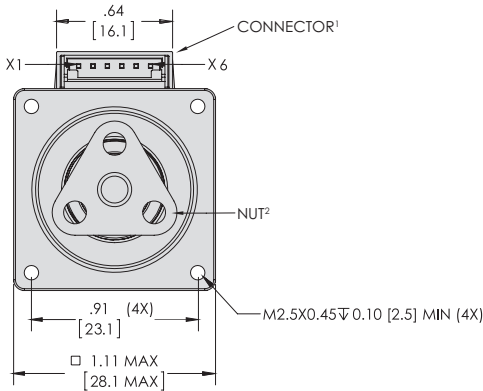

MLN Configuration

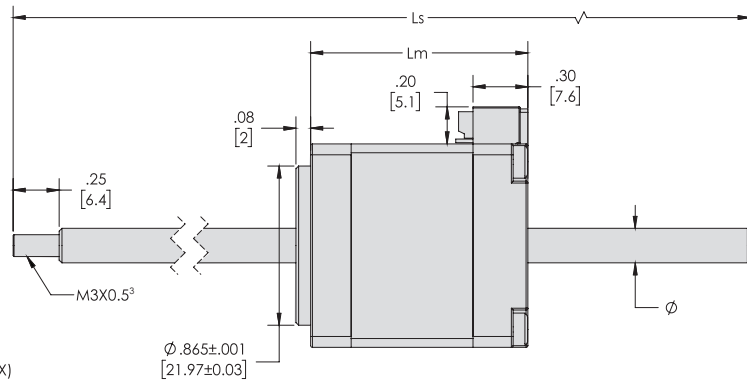
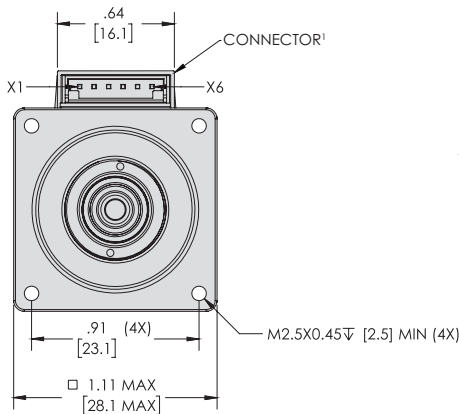

MLA Configuration

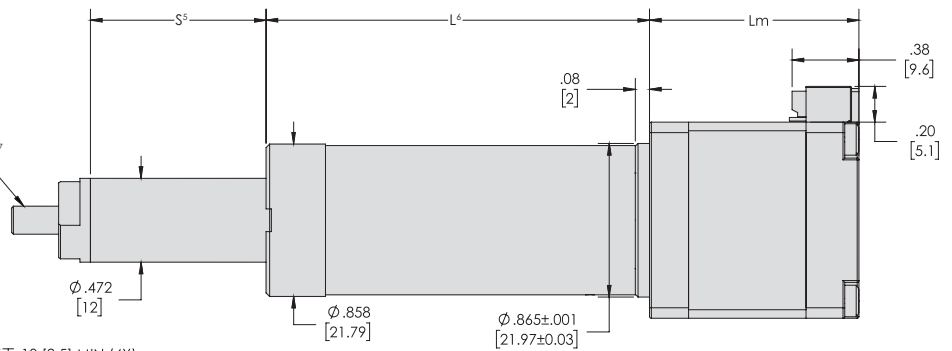
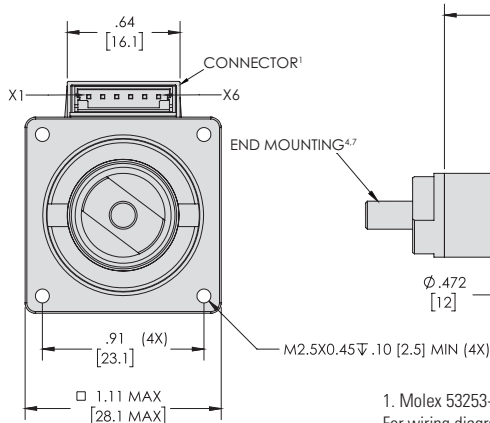

1. Molex 53253-0670 connector shown. Wire harness with Molex 51065-06000 mating connector and flying leads included with motor. For wiring diagram and connector details, see page 45.
2. RSF1800 (RS1) lead nut shown. For additional nut options, see Nut Selection table on pages 36-37.
3. Standard M3x0.5 male threaded end machining shown. For additional end-machining options, see page 15.
4. Standard M4x0.7 male end mounting (C5) shown. For additional end mount options, see page 16.
5. Max stroke length for MLA11 configurations is 2.5 in. (64 mm). End of travel collisions should be avoided. Contact Thomson for additional stroke lengths.
6. Cover tube length (L) = stroke (S) + 1.16 in. (29.5 mm).
7. Extension tube total max rotational play = +/-3 degrees. Fit can be modified. Contact Thomson for more details.



MLx11 – Performance Diagrams

MLx11A05

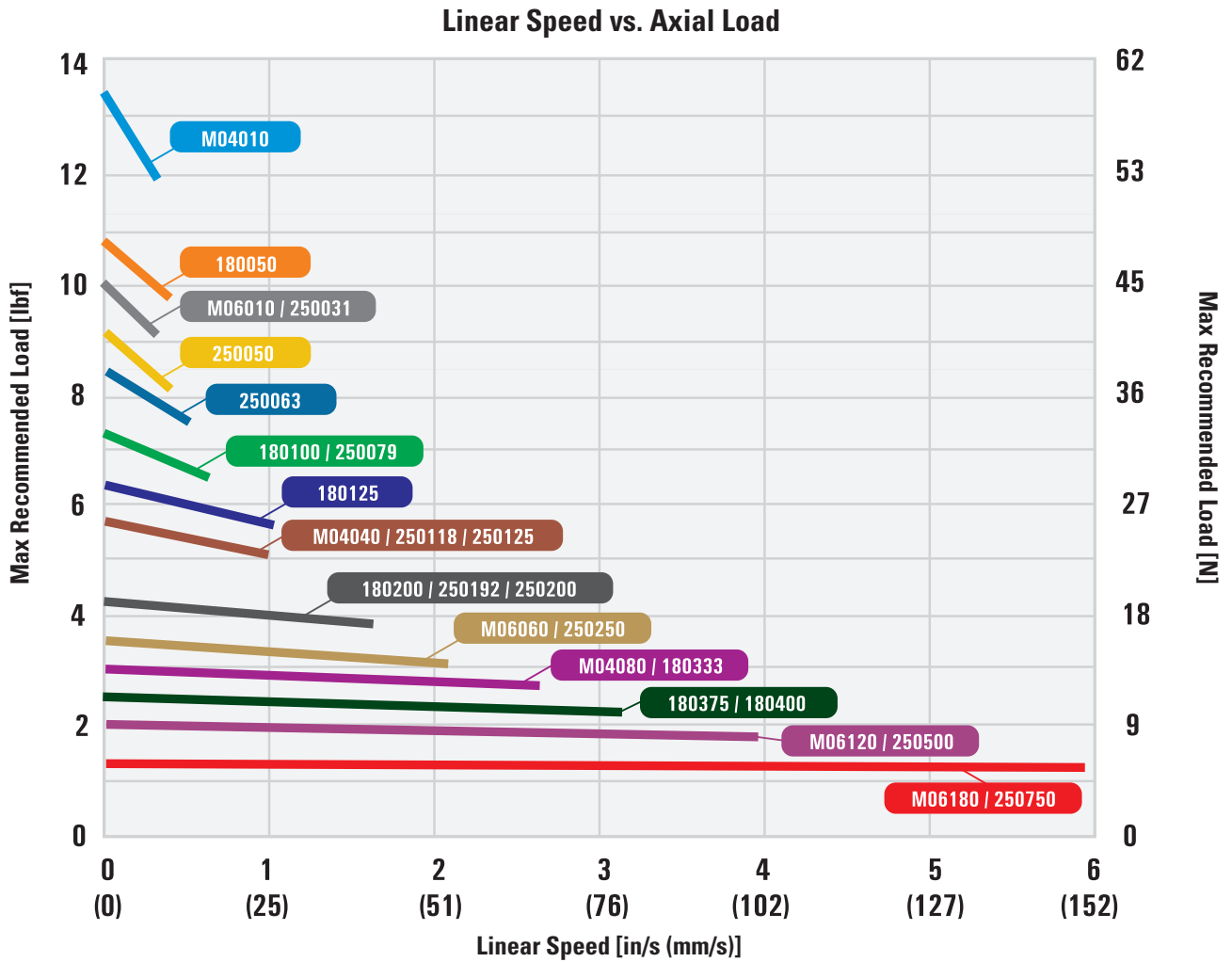

Note: Simplified performance diagrams are theoretical only and assume ideal conditions with a 24 VDC power supply, standard material lead nut and a moderate length, non-lubricated lead screw. Higher loads and speeds can be achieved. For more detailed performance plots and sizing tools, please visit www.thomsonlinear.com/en/products/motorized-lead-screws.

MLx11 – Performance Diagrams

MLx11A10

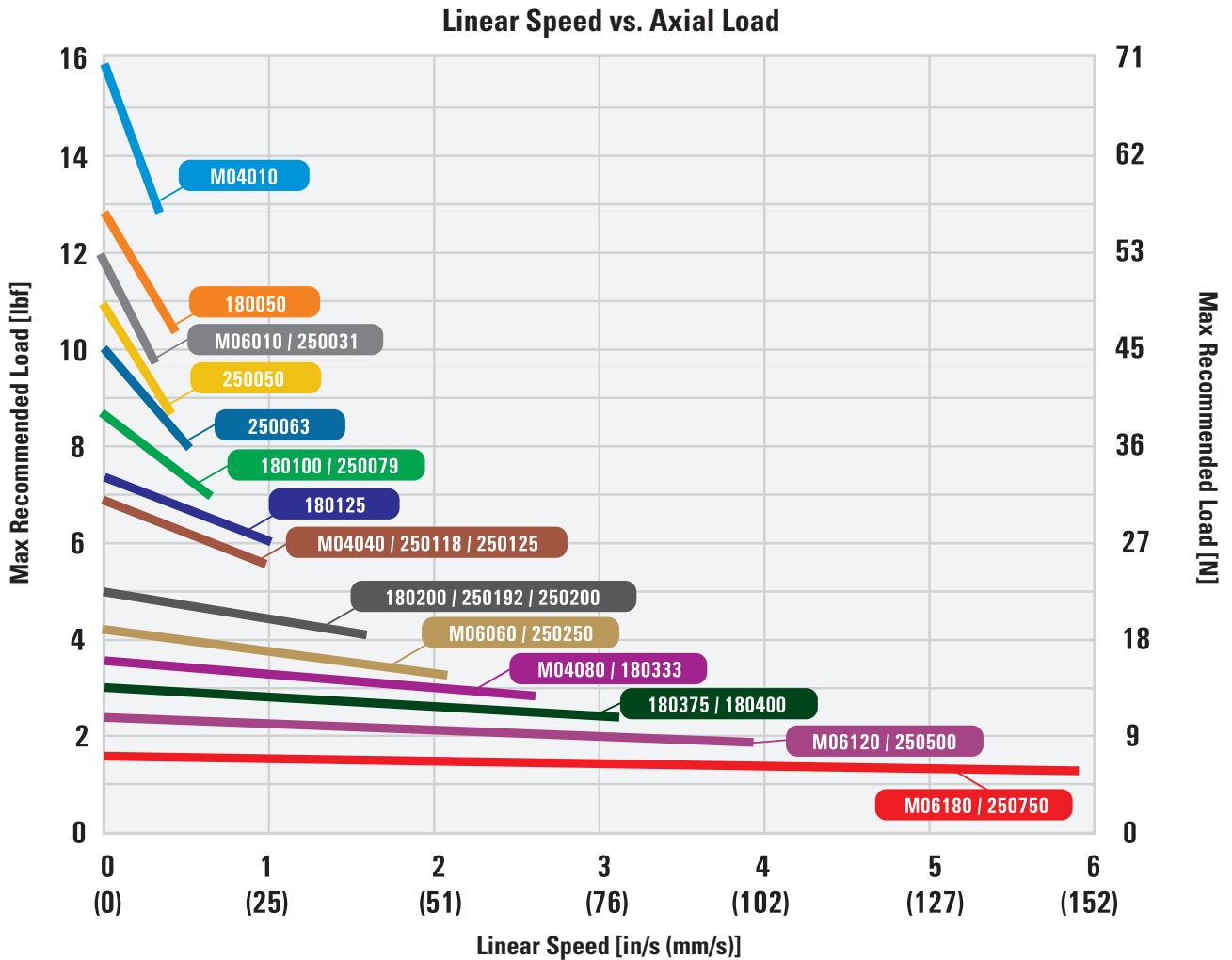

Note: Simplified performance diagrams are theoretical only and assume ideal conditions with a 24 VDC power supply, standard material lead nut and a moderate length, non-lubricated lead screw. Higher loads and speeds can be achieved. For more detailed performance plots and sizing tools, please visit www.thomsonlinear.com/en/products/motorized-lead-screws.



Specifications – MLx14 Motor Size

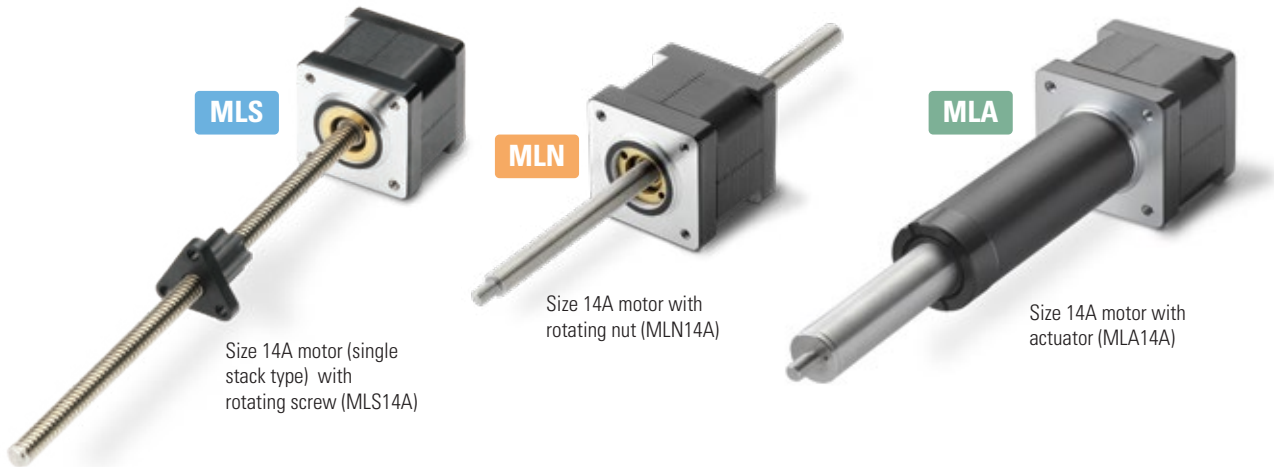

Features and Benefits

- NEMA 14 motor (size 35 mm).
- Choose between a variety of inch and metric lead screws.
- Recommended max. thrust force 50 lbs. (222 N).
- Recommended max. lead screw length of 8 in. (203 mm) for MLS / MLN and 2.5 in (64 mm) stroke for MLA.
- Side load capacity of up to 10% of axial load for MLA configurations.
- MLS and MLA configurations are encoder ready. See pages 40-41 for more details.

Motor Options

Motor code ¹	Holding torque		Voltage / phase ³ [V]	Current / phase ⁴ [A]	Resistance [Ω]	Inductance [mH]	Power draw [W]	Step angle [°]	Motor length, maximum (L _m)		Rotor inertia [oz-in ²]	Motor weight [lbs]
	[oz-in]	[N-m]							[in]	[mm]		
MLx14A08 ²	25.8	0.182	3.42	0.88	3.89	5.51	3.01	1.8	1.34	34.0	0.10	0.41
MLx14A13 ²	23.0	0.162	1.71	1.35	1.27	1.79	2.31	1.8	1.34	34.0	0.10	0.41

Inch Lead Screw Options⁵

Diameter [in.]	Lead [in]	Travel / step [in]	Screw code ⁶
0.250	0.0313	0.00016	250031 (0031)
	0.0625	0.00031	250063 (0063)
	0.1250	0.00063	250125 (0125)
	0.2500	0.00125	250250 (0250)
	0.5000	0.00250	250500 (0500)
	0.7500	0.00375	250750 (0750)

Metric Lead Screw Options⁵

Diameter [mm]	Lead [mm]	Travel / step [mm]	Screw code ⁶
6	1	0.00500	M06010 (0039)
	6	0.03000	M06060 (0236)
	12	0.06000	M06120 (0472)

1. Contact Thomson for additional available motor windings.
2. "x" denotes placeholder for S, N or A depending upon configuration.
3. Applied voltage can be any value above this number as long as output current is controlled at the rated RMS current.
4. For optimal torque output, motor should be driven at 1.41 x RMS current listed above.
5. See lead screw selection matrix on pages 12-13 for additional lead screw configurations.
6. Codes within parentheses are for MLA configurations. Screw code utilized within the full assembly part number.

Dimensions – MLx14

Dimensions	Projection
Inch [mm]	

MLS Configuration

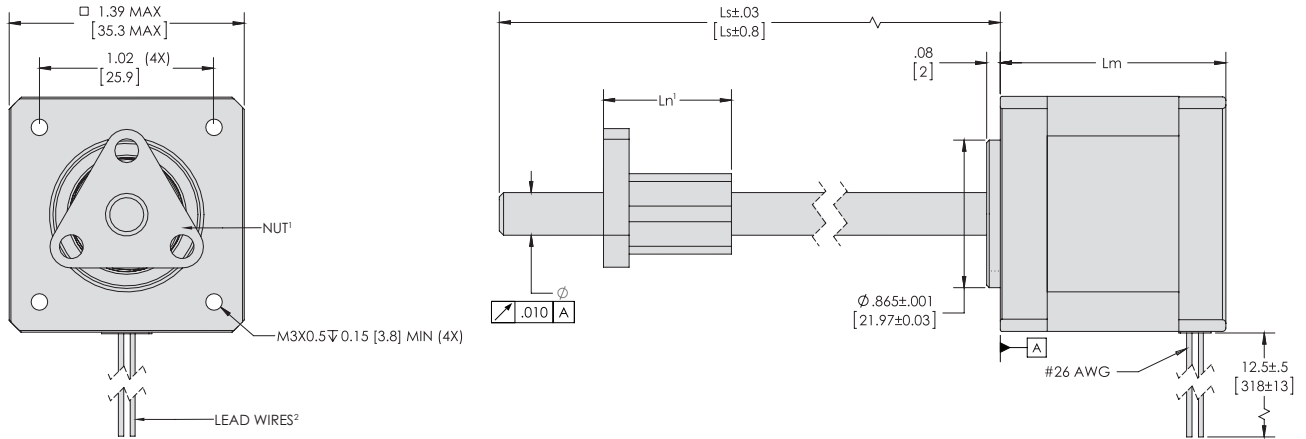

MLN Configuration

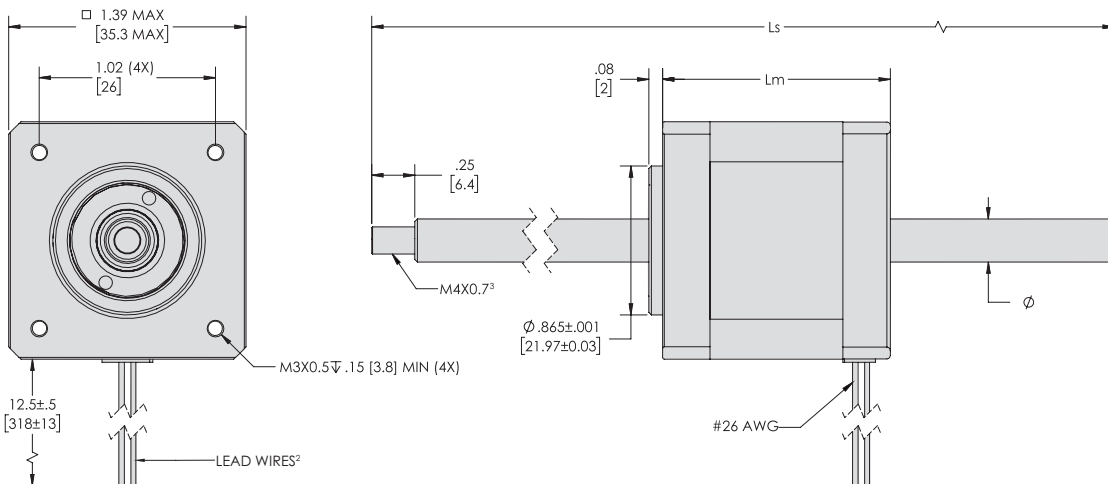

MLA Configuration

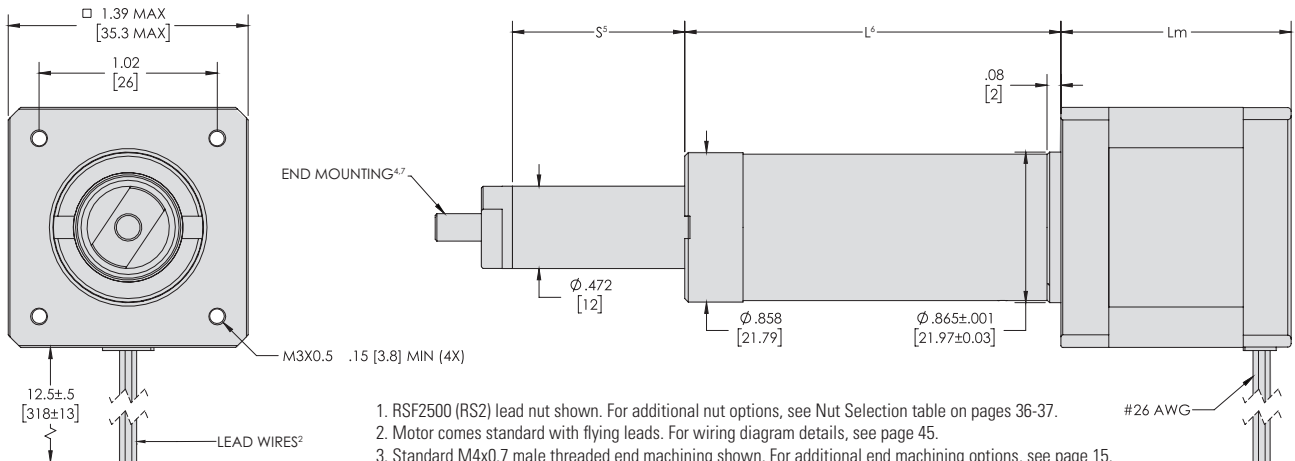

1. RSF2500 (RS2) lead nut shown. For additional nut options, see Nut Selection table on pages 36-37.
2. Motor comes standard with flying leads. For wiring diagram details, see page 45.
3. Standard M4x0.7 male threaded end machining shown. For additional end machining options, see page 15.
4. Standard M4x0.7 male end mounting (C5) shown. For additional end mount options, see page 16.
5. Max stroke length for MLA14 configurations is 2.5 in. (64 mm). End of travel collisions should be avoided. Contact Thomson for additional stroke lengths.
6. Cover tube length (L) = stroke (S) + 1.16 in. (29.5 mm).
7. Extension tube total max rotational play = +/−3 degrees. Fit can be modified. Contact Thomson for more details.



ML14 – Performance Diagrams

MLx14A08

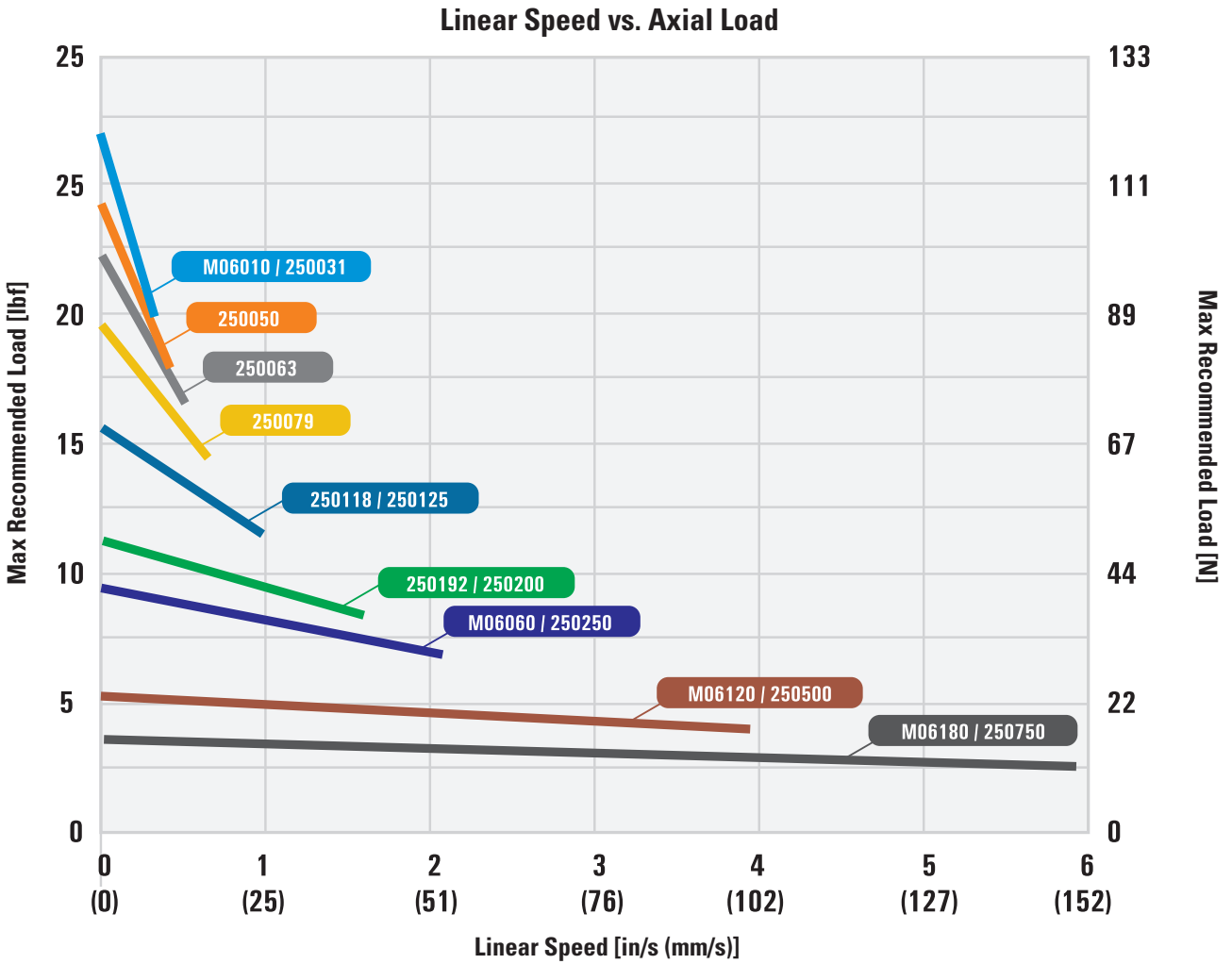

Note: Simplified performance diagrams are theoretical only and assume ideal conditions with a 24 VDC power supply, standard material lead nut and a moderate length, non-lubricated lead screw. Higher loads and speeds can be achieved. For more detailed performance plots and sizing tools, please visit www.thomsonlinear.com/en/products/motorized-lead-screws.

ML14 – Performance Diagrams

MLx14A13

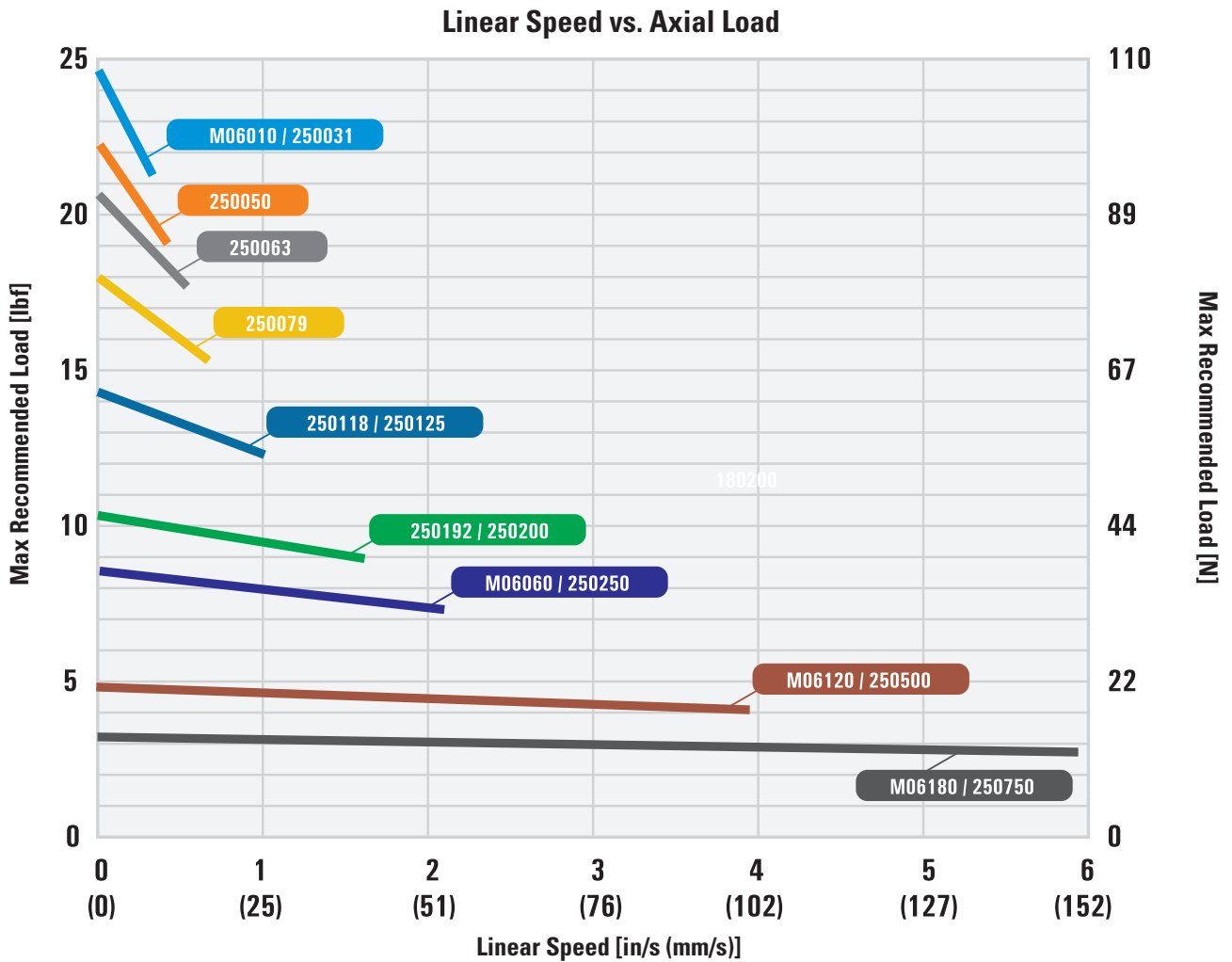

Note: Simplified performance diagrams are theoretical only and assume ideal conditions with a 24 VDC power supply, standard material lead nut and a moderate length, non-lubricated lead screw. Higher loads and speeds can be achieved. For more detailed performance plots and sizing tools, please visit www.thomsonlinear.com/en/products/motorized-lead-screws.



Specifications – MLx17 Motor Size

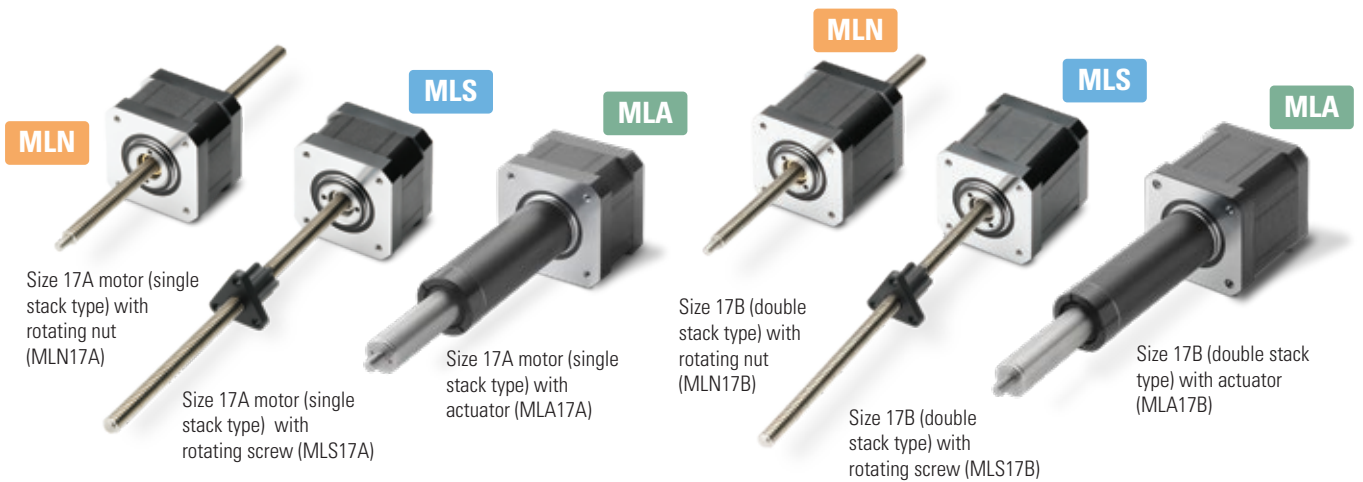

Features and Benefits

- NEMA 17 motor (size 42 mm).
- Choose between a variety of inch and metric lead screws.
- Recommended max. thrust force 75 lbs (334 N).
- Recommended max. lead screw length of 8 in. (203 mm) for MLS / MLN and 2.5 in (64 mm) stroke for MLA.
- Side load capacity of up to 10% of axial load for MLA configurations.
- MLS and MLA configurations are encoder ready. See pages 40-41 for more details.

Motor Options

Motor code ¹	Holding torque		Voltage / phase ³ [V]	Current / phase ⁴ [A]	Resistance [Ω]	Inductance [mH]	Power draw [W]	Step angle [°]	Motor length, maximum (Lm)		Rotor inertia [oz-in ²]	Motor weight [lbs]
	[oz-in]	[N-m]							[in]	[mm]		
MLx17A10 ²	77.0	0.544	2.33	1.00	2.33	5.61	2.33	1.8	1.34	34.0	0.23	0.4
MLx17A15 ²	92.0	0.650	1.76	1.50	1.17	3.26	2.63	1.8	1.34	34.0	0.23	0.4
MLx17B10 ²	107.8	0.761	1.69	1.00	1.69	5.66	1.69	1.8	1.89	48.0	0.47	0.7
MLx17B15 ²	102.8	0.726	1.31	1.50	0.87	2.7	1.96	1.8	1.89	48.0	0.47	0.7

Inch Lead Screw Options⁵

Diameter [in]	Lead [in]	Travel / step [in]	Screw code ⁶
0.250	0.0313	0.00016	250031 (0031)
	0.0625	0.00031	250063 (0063)
	0.1250	0.00063	250125 (0125)
	0.2500	0.00125	250250 (0250)
	0.5000	0.00250	250500 (0500)
	0.7500	0.00375	250750 (0750)

Metric Lead Screw Options⁵

Diameter [mm]	Lead [mm]	Travel / step [mm]	Screw code ⁶
6	1	0.00500	M06010 (0039)
	6	0.03000	M06060 (0236)
	12	0.06000	M06120 (0472)

1. Contact Thomson for additional available motor windings.
 2. "x" denotes placeholder for S, N or A depending upon configuration.
 3. Applied voltage can be any value above this number as long as output current is controlled at the rated RMS current.
 4. For optimal torque output, motor should be driven at 1.41 x RMS current listed above.
 5. See lead screw selection matrix on pages 12-13 for additional lead screw configurations.
 6. Codes within parentheses are for MLA configurations. Screw code utilized within the full assembly part number.

Dimensions – MLx17

MLS Configuration

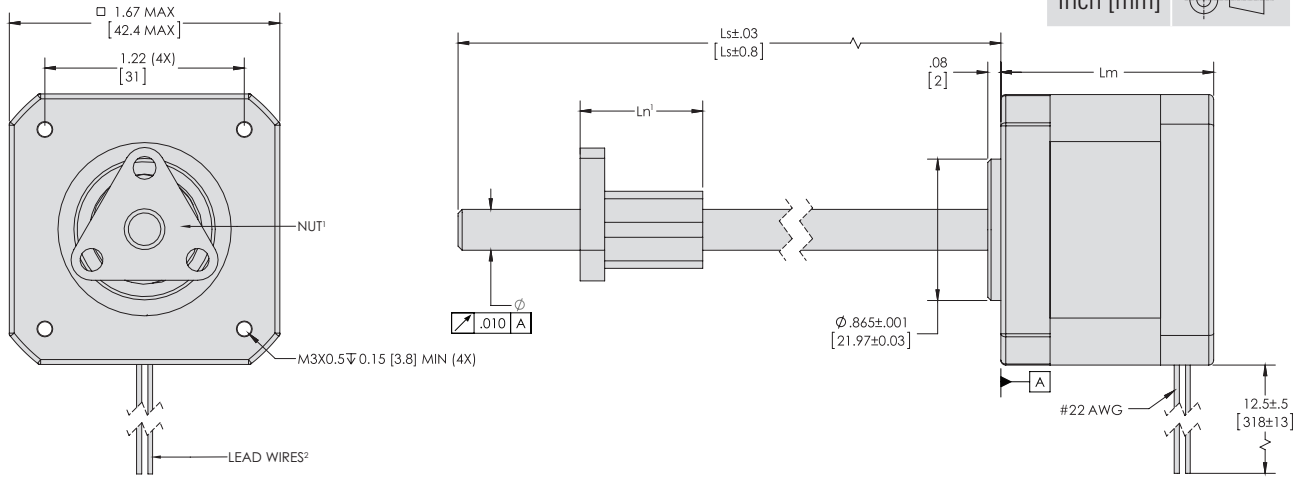

Dimensions	Projection
Inch [mm]	

MLN Configuration

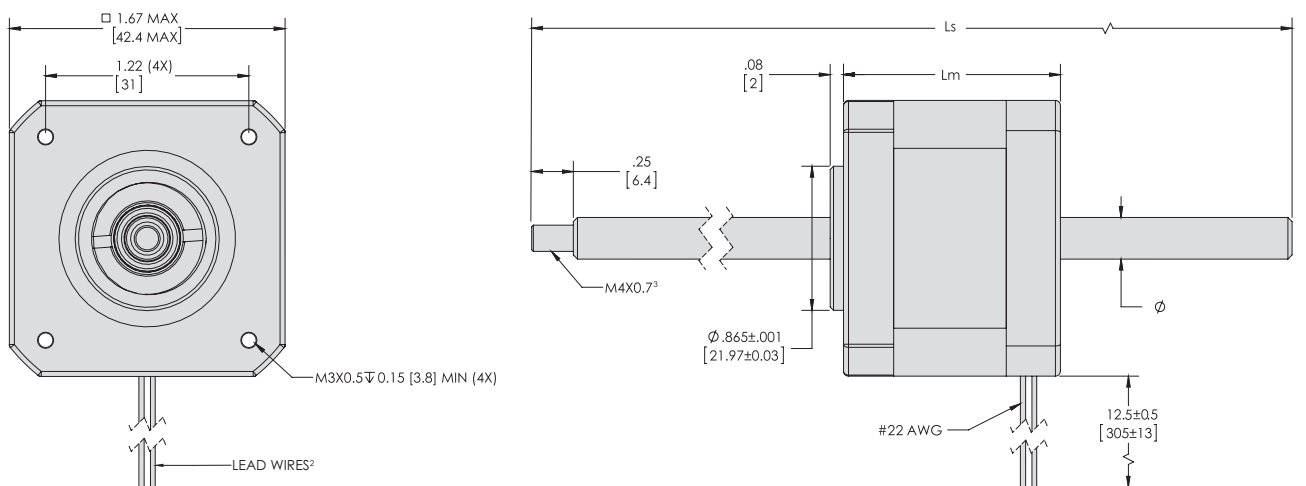

MLA Configuration

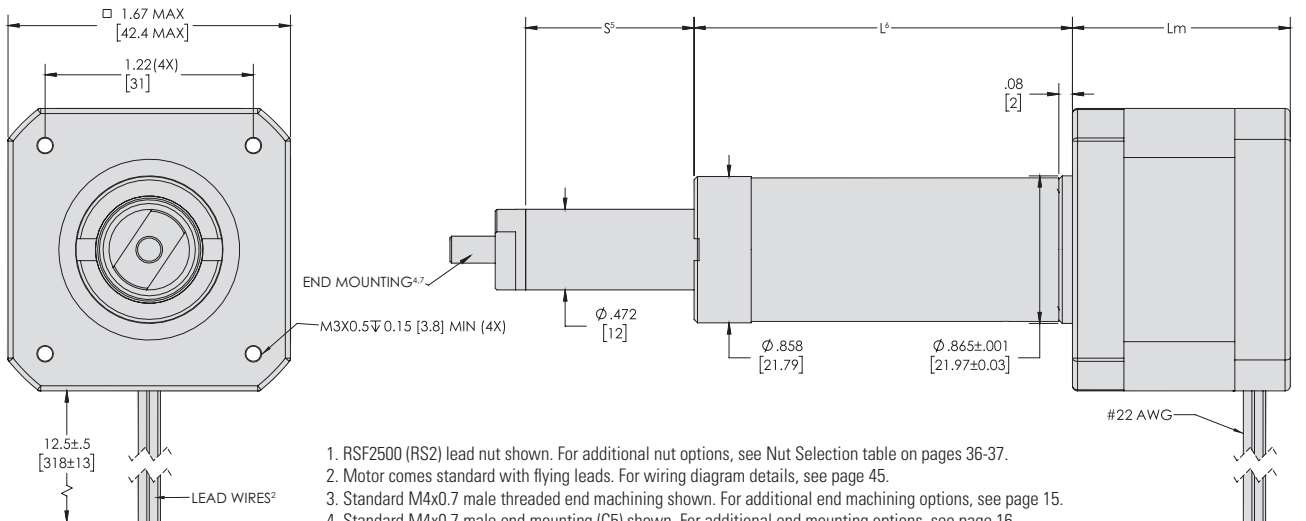

1. RSF2500 (RS2) lead nut shown. For additional nut options, see Nut Selection table on pages 36-37.
2. Motor comes standard with flying leads. For wiring diagram details, see page 45.
3. Standard M4x0.7 male threaded end machining shown. For additional end machining options, see page 15.
4. Standard M4x0.7 male end mounting (C5) shown. For additional end mounting options, see page 16.
5. Max stroke length for MLA17 configurations is 2.5 in. (64 mm). End of travel collisions should be avoided. Contact Thomson for additional stroke lengths.
6. Cover tube length (L) = stroke (S) + 1.16 in. (29.5 mm).
7. Extension tube total max rotational play = \pm 3 degrees. Fit can be modified. Contact Thomson for more details.



ML17 – Performance Diagrams

MLx17A10

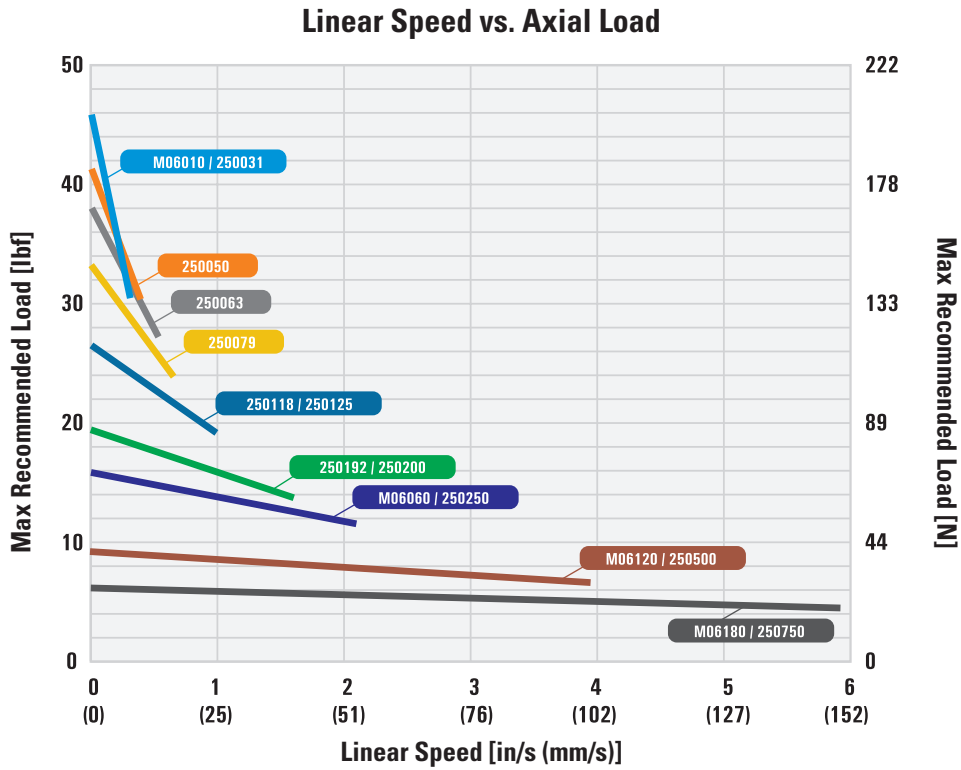

MLx17B10

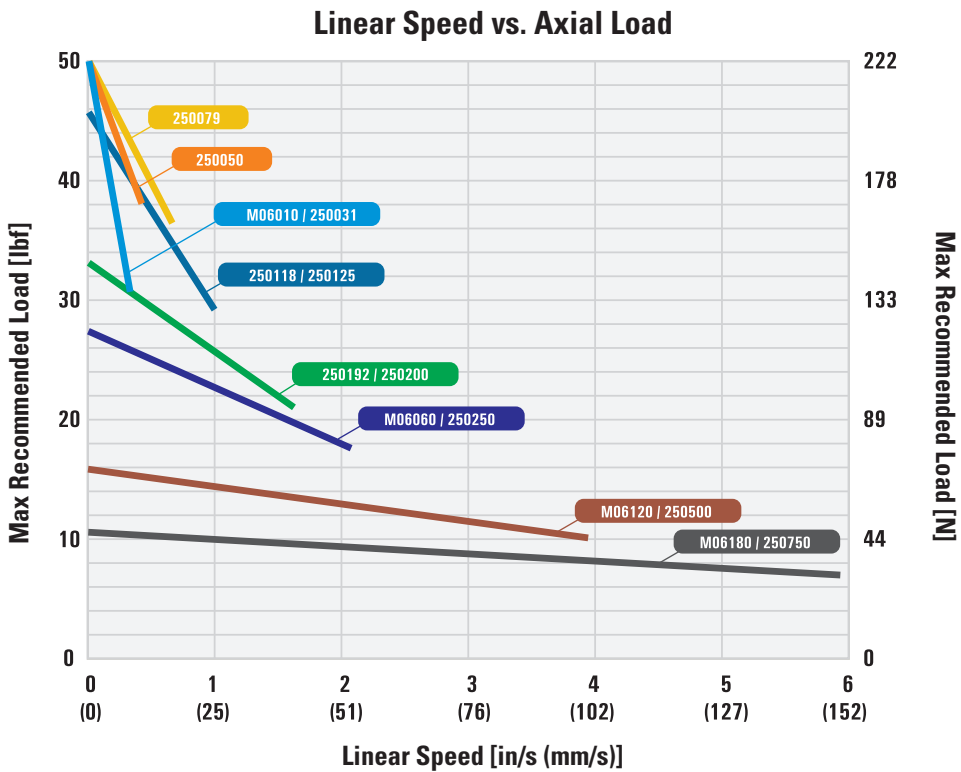

Note: Simplified performance diagrams are theoretical only and assume ideal conditions with a 24 VDC power supply, standard material lead nut and a moderate length, non-lubricated lead screw. Higher loads and speeds can be achieved. For more detailed performance plots and sizing tools, please visit www.thomsonlinear.com/en/products/motorized-lead-screws.

ML17 – Performance Diagrams

MLx17A15

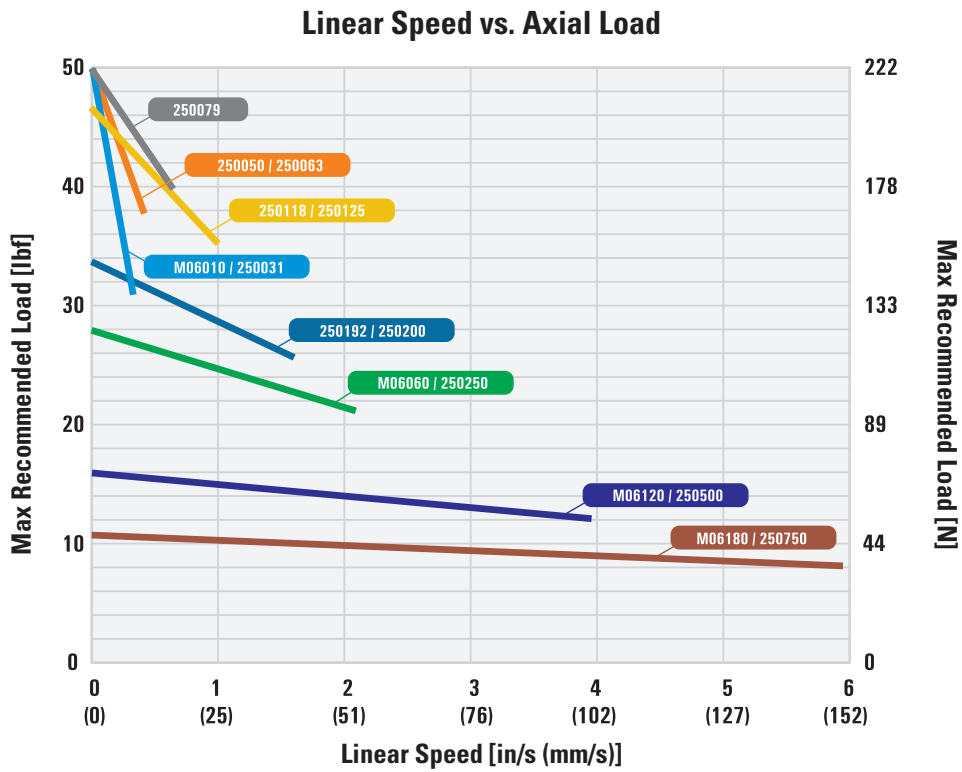

MLx17B15

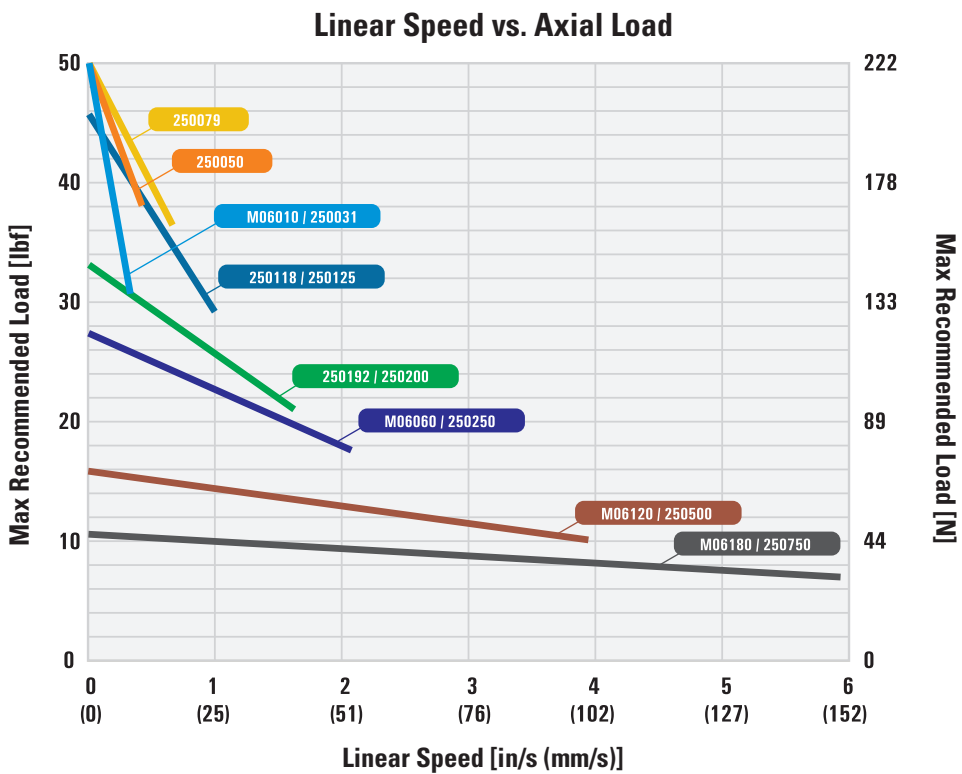

Note: Simplified performance diagrams are theoretical only and assume ideal conditions with a 24 VDC power supply, standard material lead nut and a moderate length, non-lubricated lead screw. Higher loads and speeds can be achieved. For more detailed performance plots and sizing tools, please visit www.thomsonlinear.com/en/products/motorized-lead-screws.



Specifications – MLx23 Motor Size



Features and Benefits

- NEMA 23 motor (size 57 mm).
- Choose between a variety of inch and metric lead screws.
- Recommended max. thrust force 200 lbs. (890 N).
- Recommended max. stroke length for MLA is 2.5 in. (64 mm).
- Side load capacity of up to 10% of axial load for MLA configurations.
- For MLS/MLN, recommended max. lead screw length for 0.313 in. (8 mm) diameter is 12 in. (305 mm) / max. lead screw length for 0.375 in. (10 mm) diameter is 16 in. (406 mm).
- MLS and MLA configurations are encoder ready. See pages 40-41 for more details.

Motor Options

Motor code ¹	Holding torque		Voltage / phase ³ [V]	Current / phase ⁴ [A]	Resistance [Ω]	Inductance [mH]	Power draw [W]	Step angle [°]	Motor length, maximum (Lm)		Rotor inertia [oz-in ²]	Motor weight [lbs]
	[oz-in]	[N-m]							[in]	[mm]		
MLx23A15 ²	121.0	0.854	3.77	1.55	2.43	4.20	5.84	1.8	1.78	45.2	1.04	1.13
MLx23A30 ²	123.8	0.875	1.74	3.00	0.58	1.16	5.22	1.8	1.78	45.2	1.04	1.13
MLx23B19 ²	251.2	1.774	3.80	1.90	2.00	5.84	7.22	1.8	2.59	65.8	2.13	1.70
MLx23B39 ²	260.8	1.842	1.99	3.90	0.51	1.45	7.76	1.8	2.59	65.8	2.13	1.70

Inch Lead Screw Options⁵

Diameter [in]	Lead [in]	Travel / step [in]	Screw code ⁶
0.313 ⁷	0.083	0.00042	310083
	0.167	0.00083	310167
	0.250	0.00125	310250
	0.500	0.00250	310500
	1.000	0.00500	311000
0.375	0.063	0.00031	370063 (0063)
	0.100	0.00050	370100 (0100)
	0.167	0.00083	370167 (0167)
	0.250	0.00125	370250 (0250)
	0.500	0.00250	370500 (0500)
	1.000	0.00500	371000 (1000)

Metric Lead Screw Options⁵

Diameter [mm]	Lead [mm]	Travel / step [mm]	Screw code ⁶
8 ⁷	2	0.01000	M08020
	4	0.02000	M08040
	8	0.04000	M08080
	12	0.06000	M08120
	20	0.10000	M08200
10	2	0.01000	M10020 (0079)
	3	0.01500	M10030 (0118)
	5	0.02500	M10050 (0197)
	10	0.05000	M10100 (0394)
	20	0.10000	M10200 (0787)

1. Contact Thomson for additional available motor windings.

2. "x" denotes placeholder for S, N or A depending upon configuration.

3. Applied voltage can be any value above this number as long as output current is controlled at the rated RMS current.

4. For optimal torque output, motor should be driven at 1.41 x RMS current listed above.

5. See lead screw selection matrix on pages 12-13 for additional lead screw configurations.

6. Codes within parentheses are for MLA configurations. Screw code utilized within the full assembly part number

7. Lead screw diameter not compatible with MLA configurations.

MLx23 – Dimensions

MLS Configuration

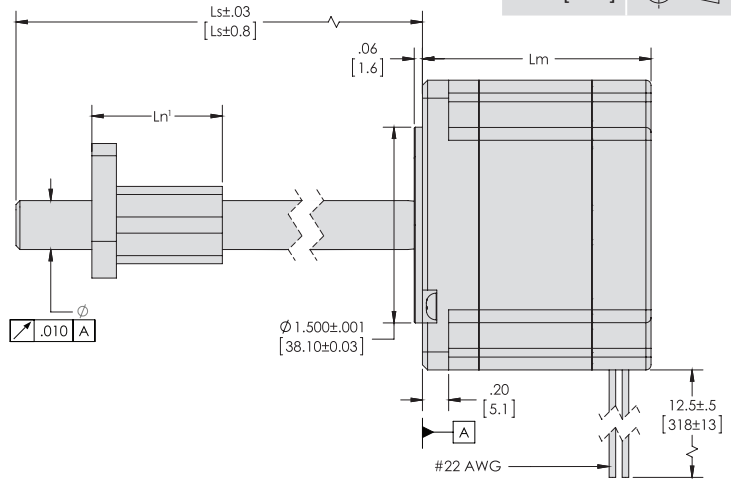
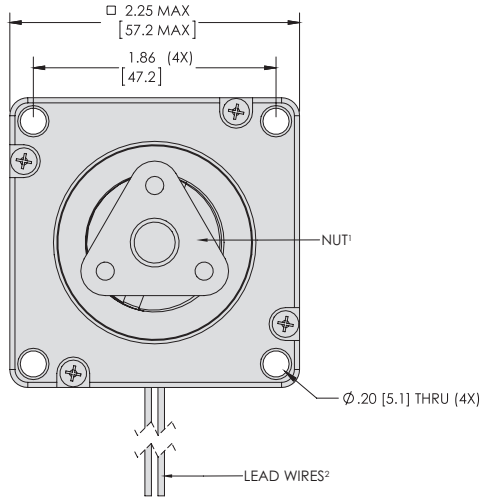

Dimensions	Projection
Inch [mm]	

MLN Configuration

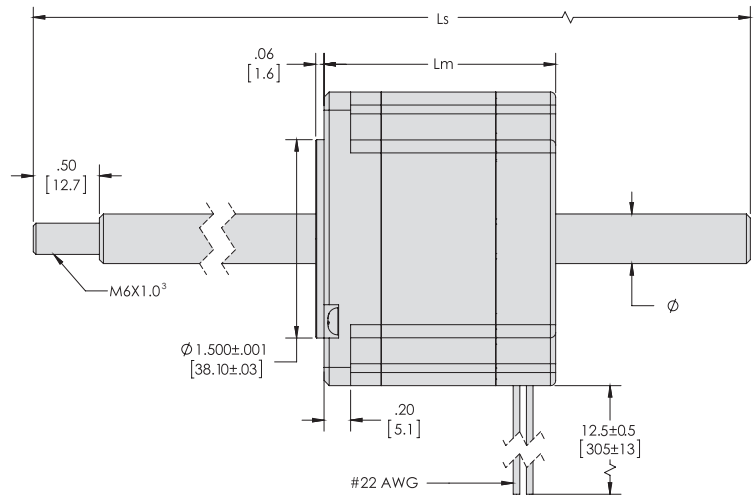
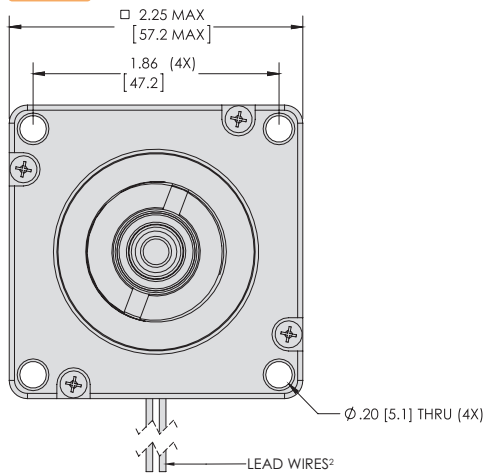

MLA Configuration

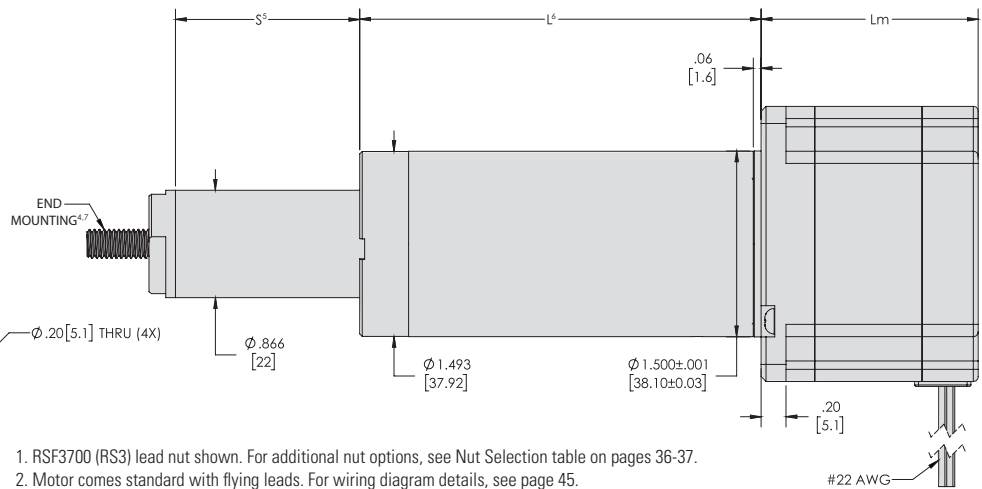
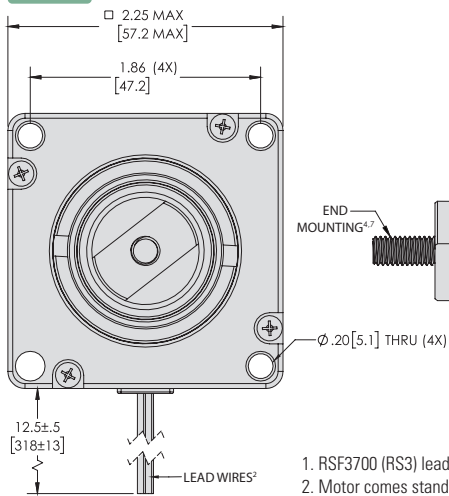

1. RSF3700 (RS3) lead nut shown. For additional nut options, see Nut Selection table on pages 36-37.
2. Motor comes standard with flying leads. For wiring diagram details, see page 45.
3. Standard M6x1.0 male threaded end machining shown. For additional end machining options, see page 15.
4. Standard M6x1.0 male end mounting (C5) shown. For additional end mounting options, see page 16.
5. Max stroke length for MLA23 configurations is 2.5 in. (64 mm). End of travel collisions should be avoided. Contact Thomson for additional stroke lengths.
6. Cover tube length (L) = stroke (S) + 1.74 in. (44.2 mm).
7. Extension tube total max rotational play = +/-2 degrees. Fit can be modified. Contact Thomson for more details.



ML23 – Performance Diagrams

MLx23A15

Linear Speed vs. Axial Load

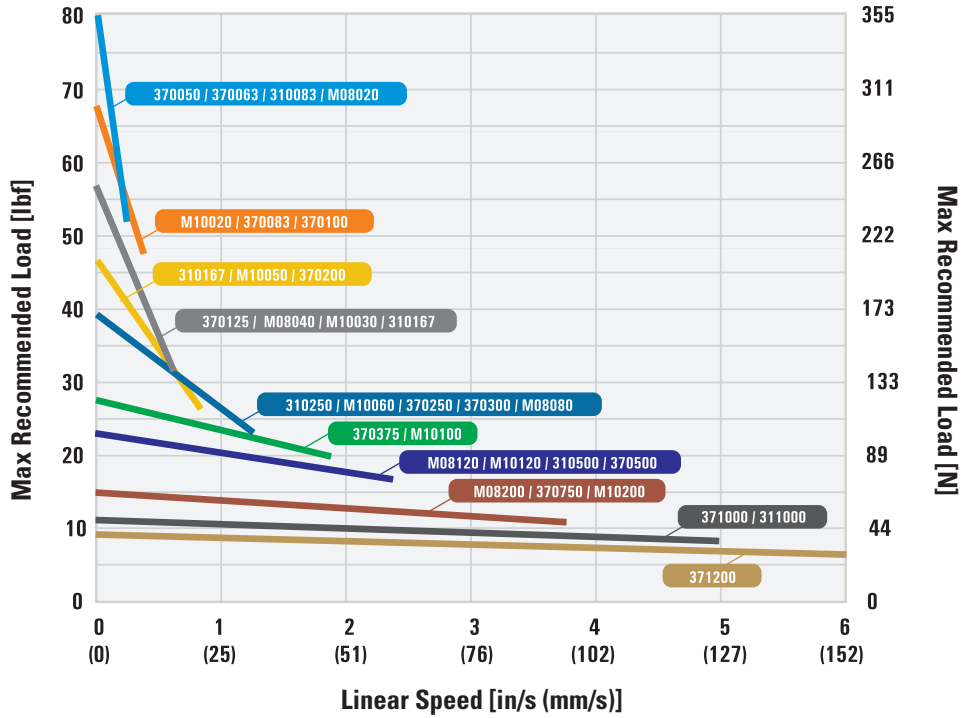

MLx23B19

Linear Speed vs. Axial Load

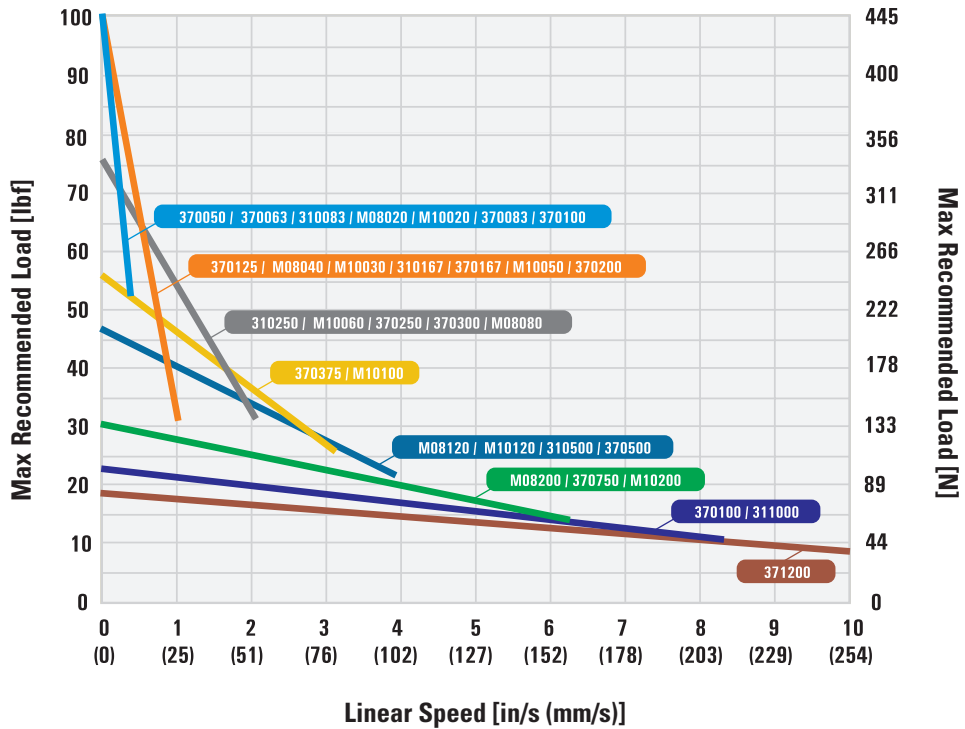

Note: Simplified performance diagrams are theoretical only and assume ideal conditions with a 24 VDC power supply, standard material lead nut and a moderate length, non-lubricated lead screw. Higher loads and speeds can be achieved. For more detailed performance plots and sizing tools, please visit www.thomsonlinear.com/en/products/motorized-lead-screws.

ML23 – Performance Diagrams

ML23A30

Linear Speed vs. Axial Load

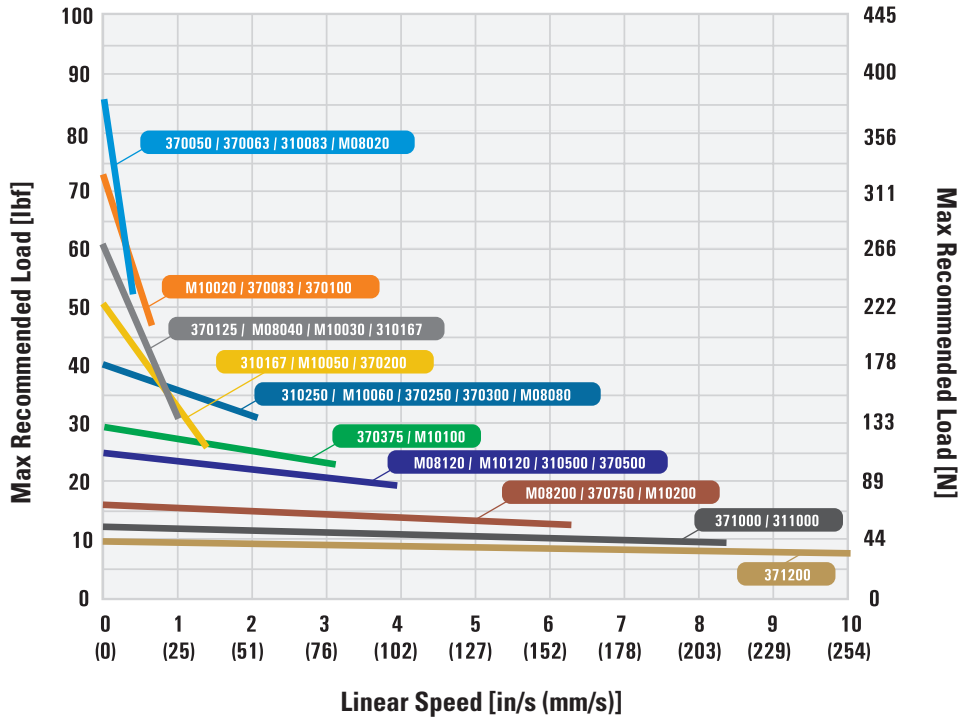

ML23B39



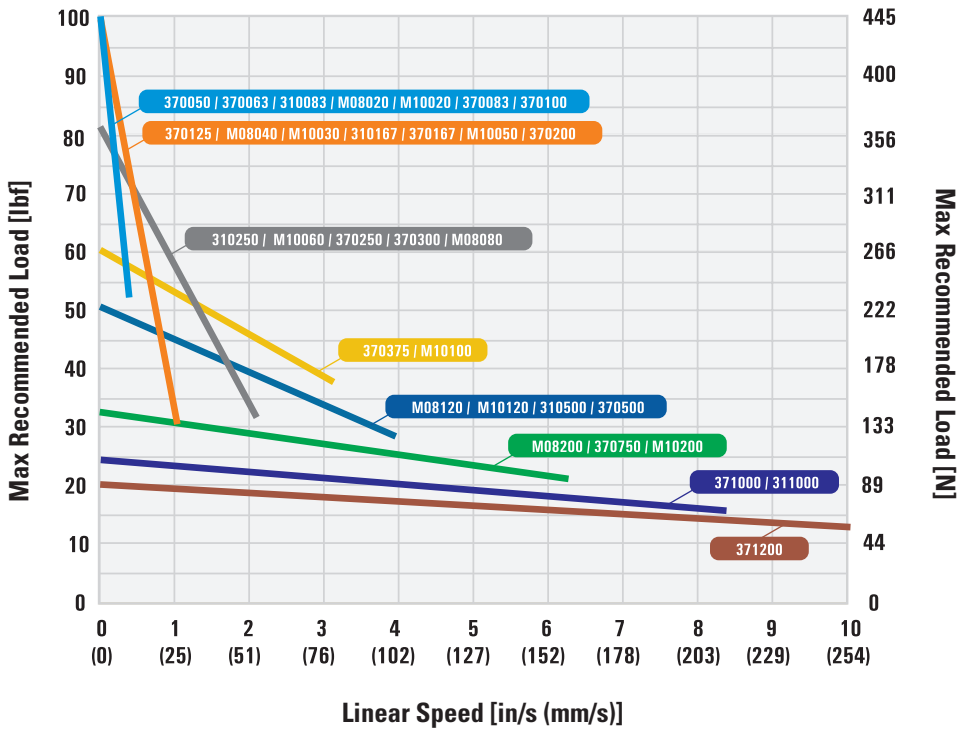



Linear Speed vs. Axial Load



Note: Simplified performance diagrams are theoretical only and assume ideal conditions with a 24 VDC power supply, standard material lead nut and a moderate length, non-lubricated lead screw. Higher loads and speeds can be achieved. For more detailed performance plots and sizing tools, please visit www.thomsonlinear.com/en/products/motorized-lead-screws.



Nut Selection

Lead Nut							
Series	Image	Part Number	P/N Ref. ¹	Compatible Motor(s)	Catalog Design Load ² (lbf)		
RSF		RSF1800	RS1	08, 11	10		
		RSF2500	RS2	11, 14, 17	25		
		RSF3700	RS3	14, 17, 23	60		
RSFH		RSFH1800	RH1	08, 11	20		
		RSFH2500	RH2	11, 14, 17	50		
		RSFH3700	RH3	14, 17, 23	120		
XC ³			XCMF1800	XF1	08, 11	5	
			XCMT1800	XT1	08, 11	5	
			XCMF2500	XF1	11, 14, 17	5	
			XCMT2500	XT1	11, 14, 18	5	
			XCF3700SH	FS3	14, 17, 23	25	
			XCT3700SH	TS3	14, 17, 23	25	
	XCF3700		XF3	14, 17, 23	25		
	XCT3700		XT3	14, 17, 23	25		
	XCF5000		XF5	23	125		
	XCT5000		XT5	23	125		
	XCF2500		XF2	11, 14, 17	10		
	XCT2500		XT2	11, 14, 17	10		
MTS		MTS1800	MT2	08, 11	10		
		MTS2500	MT2	14, 17	10		
		MTS3100	MT2	14, 17, 23	50		
		MTS3700	MT3	14, 17, 23	60		
		MTS4300	MT3	14, 17, 23	60		
		MTS5000	MT5	14, 17, 23	125		
SN		SN1800	SN2	08, 11	30		
		SN2500	SN2	14, 17	45		
		SN3100	SN3	14, 17, 23	70		
		SN3700	SN3	14, 17, 23	70		
		SN5000	SN5	14, 17, 23	100		
AFT		AFT2500	AF2	14, 17	5		
		AFT3700	AF3	14, 17, 23	10		
		AFT5000	AF5	23	25		
SNAB ⁴		SNAB1800	SB2	08, 11	10		
		SNAB2500	SB2	14, 17	25		
		SNAB3100	SB3	14, 17, 23	50		
		SNAB3700	SB3	14, 17, 23	70		
		SNAB5000	SB5	14, 17, 23	150		

1. Three-digit reference to be used within the full MLS part number.

2. Approximate max running load assuming 500 RPM and 50% duty cycle. For more detailed design limitations and sizing, contact Thomson.

3. Some high-lead configurations are not available for the XC nut.

4. Preload force is lower than stated design load. Exceeding preload force will cause spring to fully compress, and nut will lose anti-backlash properties. Preload force values: SNAB1800/SNAB2500 = 1-3 lbs, SNAB3100/3700 = 2-5 lbs, and SNAB5000 = 4-9 lbs.

Lead Screw												About
0.188 in.	4 mm	0.25 in.	6 mm	0.313 in.	8 mm	0.375 in.	10 mm	0.43 in.	0.50 in.	12 mm		
x	x											Standard triangular flange bearing grade acetal nut used on stepper motor linear actuators.
		x	x									
				x	x	x	x					
x	x											Higher performance bearing grade PEEK alternative to standard RSF nut used on stepper motor linear actuators. Capable of withstanding higher loads, speeds and temperature requirements.
		x	x									
				x	x	x	x					
x	x											Standard triangular flange / thread mount XC nuts used for 0.188 in. (4 mm) lead screws.
x	x											
		x	x									Standard triangular flange / thread mount XC nuts used for 0.25 in. (6 mm) lead screws.
		x	x									
				x	x	x	x					Standard triangular flange / thread mount XC nuts used for 0.313 in. (8 mm) and 0.375 in. (10 mm) lead screws with short nut body length.
				x	x	x	x					
				x	x	x	x					
				x	x	x	x					
								x	x	x		Standard round flange / thread mount XC nuts used for 0.5 in. (12 mm) lead screws.
								x	x	x		
		x	x									Flat flange (2-hole) and larger nut body alternative to XCM nut for 0.25 in. (6 mm) lead screws when a higher design load is required.
		x	x									
		x	x									Triangular and round flange alternative to RSF nut. Identical bearing grade material but with overall larger dimensions over RSF nut.
				x	x							
						x	x					
								x				
									x	x		Thread mount bearing grade acetal nut with standard backlash.
										x	x	
		x	x									Triangular flange alternative anti-backlash nut.
				x	x	x	x	x				
									x	x		
x	x											Thread mount alternative anti-backlash nut.
		x	x									
				x	x							
						x	x					
								x	x	x		



General Nut Dimensions

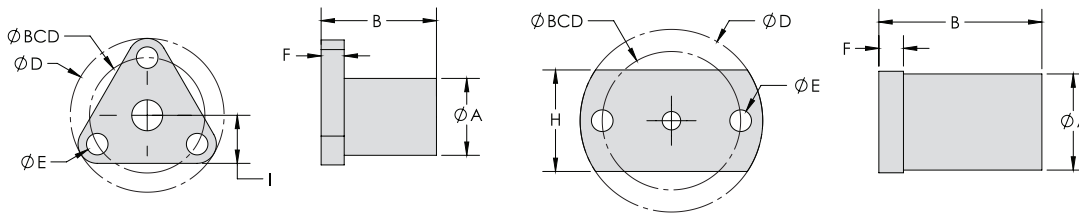

RSF, MTS3700, XCF3700, XCMF, AFT2500 and AFT5000

XCF2500

Lead Nut	Series	RSF/RSFH			XC							
	P/N	RSF1800 / RSFH1800 (RS1 / RH1)	RSF2500 / RSFH2500 (RS2 / RH2)	RSF3700 / RSFH3700 (RS3 / RH3)	XCMF1800 / XCMF2500 (XF1 / XF1)	XCF3700SH (FS3)	XCF5000 (XF5)	XCF2500 (XF2)	XCMT1800 / XCMT2500 (XT1 / XT1)	XCT3700SH (TS3)	XCT5000 (XT5)	XCT2500 (XT2)
A	0.313 (7.95)	0.5 (12.7)	0.63 (16)	0.5 (12.7)	0.81 (20.57)	1.12 (28.44)	0.64 (16.25)	0.5 (12.7)	0.81 (20.57)	1.12 (28.44)	0.64 (16.25)	
B ¹	0.375 (9.52)	0.75 (19.05)	1 (25.4)	0.9 (22.86)	1.34 (34.03)	2.25 (57.15)	1.18 (29.97)	0.9 (22.86)	1.34 (34.03)	2.25 (57.15)	1.18 (29.97)	
C	-	-	-	-	-	-	-	0.2 (5.08)	0.25 (6.35)	0.375 (9.52)	0.187 (4.74)	
D	0.75 (19.05)	1 (25.4)	1.25 (31.75)	1 (25.4)	1.53 (38.86)	1.75 (44.45)	1.19 (30.22)	-	-	-	-	
E	0.13 (3.3)	0.14 (3.55)	0.14 (3.55)	0.14 (3.55)	0.197 (5)	0.2 (5.08)	0.141 (3.58)	-	-	-	-	
F	0.13 (3.3)	0.15 (3.81)	0.19 (4.82)	0.18 (4.57)	0.2 (5.08)	0.3 (7.62)	0.16 (4.06)	-	-	-	-	
G	-	-	-	-	-	-	-	-	-	-	-	
H	-	-	-	-	-	-	0.66 (16.76)	-	-	-	-	
I	0.25 (6.35)	0.31 (7.87)	0.41 (10.41)	0.31 (7.87)	0.48 (20.32)	-	-	-	-	-	-	
J	-	-	-	-	-	-	-	-	-	-	-	
BCD	0.5 (12.7)	0.75 (19.05)	0.875 (22.22)	0.75 (19.05)	1.125 (28.57)	1.406 (35.71)	0.9 (22.86)	-	-	-	-	
THD ²	-	-	-	-	-	-	-	7/16-20	5/8-18	15/16-16	9/16-18	

1. Dimension B shown is max length.
2. Metric mounting thread available. Contact Thomson for more information.

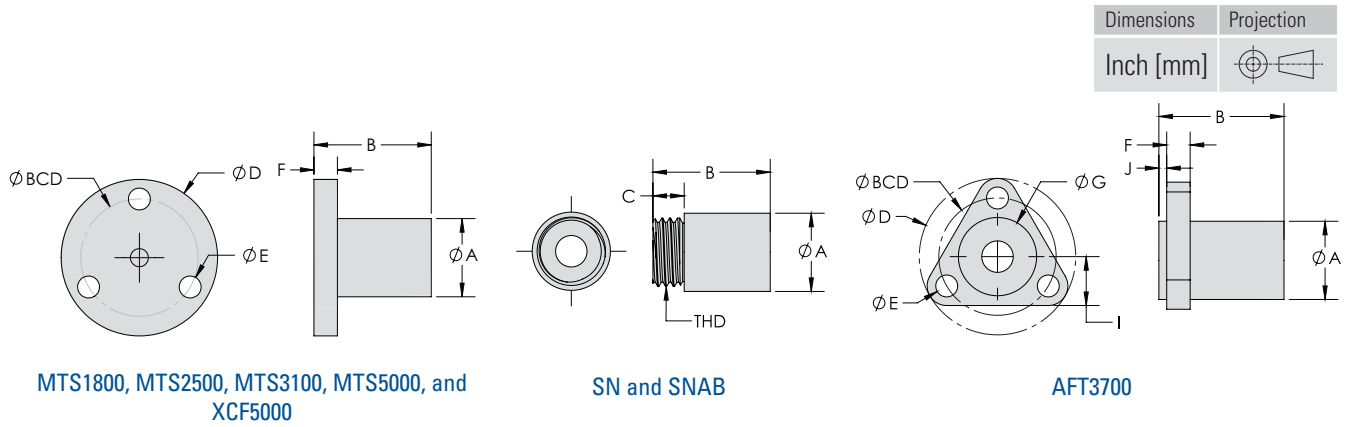

Dimensions	Projection
Inch [mm]	

	Lead Nut	Series	MTS			SN			AFT			SNAB		
		P/N	MTS1800 / MTS2500 / MTS3100 (MT2 / MT2 / MT2)	MTS3700 / MTS4300 (MT3 / MT3)	MTS5000 (MT5)	SN1800 / SN2500 (SN2 / SN2)	SN3100 / SN3700 (SN3 / SN3)	SN5000 (SN5)	AFT2500 (AF2)	AFT3700 (AF3)	AFT5000 (AF5)	SNAB1800 / SNAB2500 (SB2 / SB2)	SNAB3100 / SNAB3700 (SB3 / SB3)	SNAB500 (SB5)
		A	0.5 (12.7)	0.71 (18.03)	0.75 (19.05)	0.625 (15.87)	0.75 (19.05)	1 (25.4)	0.5 (12.7)	0.77 (19.55)	0.88 (22.35)	0.625 (15.87)	0.75 (19.05)	1 (25.4)
		B ¹	0.75 (19.05)	1.5 (38.1)	1.5 (38.1)	0.5 (12.7)	0.75 (19.05)	1 (25.4)	0.99 (25.14)	2 (50.8)	2.03 (51.56)	1.25 (31.75)	1.34 (34.03)	2 (50.8)
		C	-	-	-	0.187 (4.74)	0.25 (6.35)	0.375 (9.52)	-	-	-	0.187 (4.74)	0.25 (6.35)	0.375 (9.52)
		D	1 (25.4)	1.5 (38.1)	1.5 (38.1)	-	-	-	1 (25.4)	1.5 (38.1)	1.62 (41.14)	-	-	-
		E	0.14 (3.55)	0.2 (5.08)	0.2 (5.08)	-	-	-	0.14 (3.55)	0.2 (5.08)	0.2 (5.08)	-	-	-
		F	0.15 (3.81)	0.2 (5.08)	0.25 (6.35)	-	-	-	0.18 (4.57)	0.2 (5.08)	0.25 (6.35)	-	-	-
		G	-	-	-	-	-	-	-	0.71 (18.03)	-	-	-	-
		H	-	-	-	-	-	-	-	-	-	-	-	-
		I	-	0.469 (11.91)	-	-	-	-	0.313 (7.95)	0.469 (11.91)	0.5 (12.7)	-	-	-
		J	-	-	-	-	-	-	-	0.06 (1.5)	-	-	-	-
		BCD	0.75 (19.05)	1.125 (28.57)	1.125 (28.57)	-	-	-	0.75 (19.05)	1.125 (28.57)	1.25 (31.75)	-	-	-
		THD ²	-	-	-	9/16-18	5/8-18	15/16-16	-	-	-	9/16-18	5/8-18	15/16-16



Specifications – Encoders



Pictured: MLS23B motor with E3 encoder



Features and Benefits

- All MLS and MLA configurations are available with rear-mounted optical encoders (except for size 8)
- Two channel quadrature square wave outputs with optional third channel index output
- Various cycles per revolution (CPR) or pulses per revolution (PPR) available – from 32 to 10,000 CPR or 128 to 40,000 PPR

Available Encoder Configurations

Encoder Model	CPR	Index	Output	Compatible Motors
E2	32 ¹ , 50, 96, 100, 120 ¹ , 192, 200, 250, 256, 360, 400, 500, 512, 540, 720, 900, 1000, 1024, 1250, 2000 ² , 2048 ² , 2500 ² , 4000 ² , 4096 ² , 5000 ²	Index or Non-Index	Single-Ended	11, 14, 17
E3	64 ¹ , 100, 200, 400, 500, 512, 1000, 1024, 1800, 2000, 2048, 2500, 3600 ² , 4000 ² , 4096 ² , 5000 ² , 7200 ² , 8000 ² , 8192 ² , 10000 ²	Index or Non-Index	Single-Ended	17, 23
E4T	100, 108, 120, 125, 128, 144, 200, 248, 250, 256, 296, 300, 360, 400, 500, 512, 720, 800, 1000	Non-Index	Single-Ended or Differential	8
E5	32 ¹ , 50, 96, 100, 192, 200, 250, 256, 360, 400, 500, 512, 540, 720, 900, 1000, 1024, 1250, 2000 ² , 2048 ² , 2500 ² , 4000 ² , 4096 ² , 5000 ²	Index or Non-Index	Single-Ended or Differential	11, 14, 17
E6	64 ¹ , 100, 200, 400, 500, 512, 800 ² , 1000, 1024, 1800, 2000, 2048, 2500, 3600 ² , 4000 ² , 4096 ² , 5000 ² , 7200 ² , 8000 ² , 8192 ² , 10000 ²	Index or Non-Index	Single-Ended or Differential	17, 23

1. CPR available with Non-Index only

2. CPR available with Index only

Note: Please specify encoder model, CPR, Index and Output (if applicable)

Dimensions – Encoders

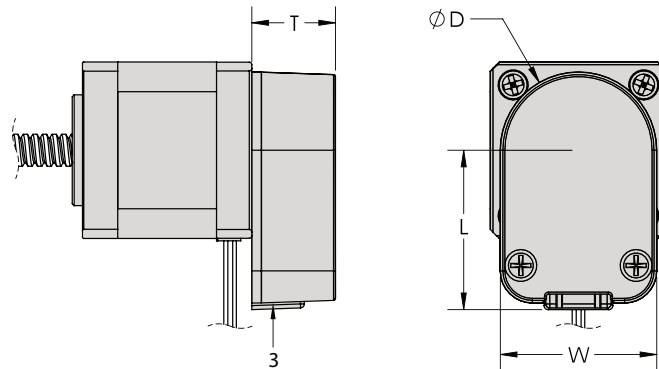

Encoder Specifications

Encoder	Dimensions (inch [mm])				Mating Connector ^{2,3}	Supply Voltage ⁴ (VDC)			Operating Temperature (°F [°C])		Max Acceleration (rad/sec ²)	
	T ¹	L	D	W		US Digital	Min	Typ	Max	Min		Max
E2	0.62 [15.7]	0.82 [20.8]	1.19 [30.2]	1.19 [30.2]	CON-C5 CON-LC5	4.5	5.0	5.5	-40 [-40]		212 [100]	250,000
E3		0.57 [14.4]	2.2 [55.9]	1.62 [41.1]								
E4T	0.45 [11.3]	0.51 [12.8]	0.87 [22]	0.58 [14.6]	CON-MIC4				-4 [-20]			
E5	0.65 [16.6]	1.24 [31.6]	1.22 [31.1]	1.22 [31.1]	CON-FC5 (5 PIN) CON-FC10 (10 PIN)				-40 [-40] (CPR<2000) -25 [-13] (CPR≥2000)			
E6		1.42 [36]	2.22 [56.4]	1.39 [35.2]					-40 [-40] (CPR<3600) -25 [-13] (CPR≥3600)			

1. MLx17 motor requires mounting plate, which increases dimension T by approximately 0.15 in [3.8 mm].
 2. All single-ended encoders are 4- or 5-pin connections. All differential encoders are 10-pin connections.
 3. Encoder connectors and cables not provided.
 4. For more detailed electrical specifications, visit www.usdigital.com.

Pinouts

Pin	E2, E3	E4T		E5, E6	
		Single-Ended	Differential	Single-Ended	Differential
1	Ground	+5 VDC Power	Ground	Ground	Ground
2	Index	A Channel	A+ Channel	Index	Ground
3	A Channel	Ground	A- Channel	A Channel	Index-
4	+5 VDC Power	B Channel	+5 VDC Power	+5 VDC Power	Index+
5	B Channel	-	B+ Channel	B Channel	A- Channel
6	-	-	B- Channel	-	A+ Channel
7	-	-	-	-	+5 VDC Power
8	-	-	-	-	+5 VDC Power
9	-	-	-	-	B- Channel
10	-	-	-	-	B+ Channel

OUTPUT WAVEFORMS

SINGLE-ENDED

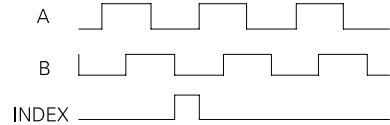

DIFFERENTIAL

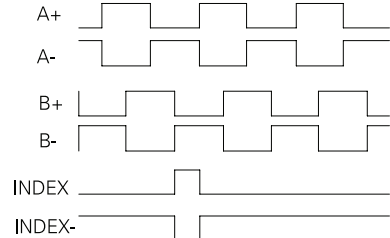

SINGLE-ENDED

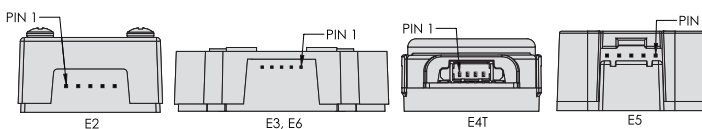

DIFFERENTIAL

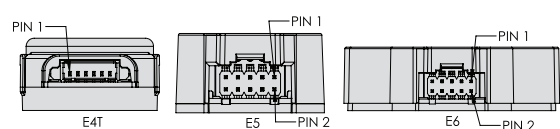



Make it Yours By Customizing a Stepper Motor Linear Actuator

Thomson routinely collaborates with original equipment manufacturers globally to solve problems, boost efficiency and enhance the value passed on to their customers. Our technology and application experience can be harnessed to help you go beyond standard products to fit the exact needs on your next product.

Below you'll see an example of some common customizations for stepper motor linear actuator products. See next page for details on each option.

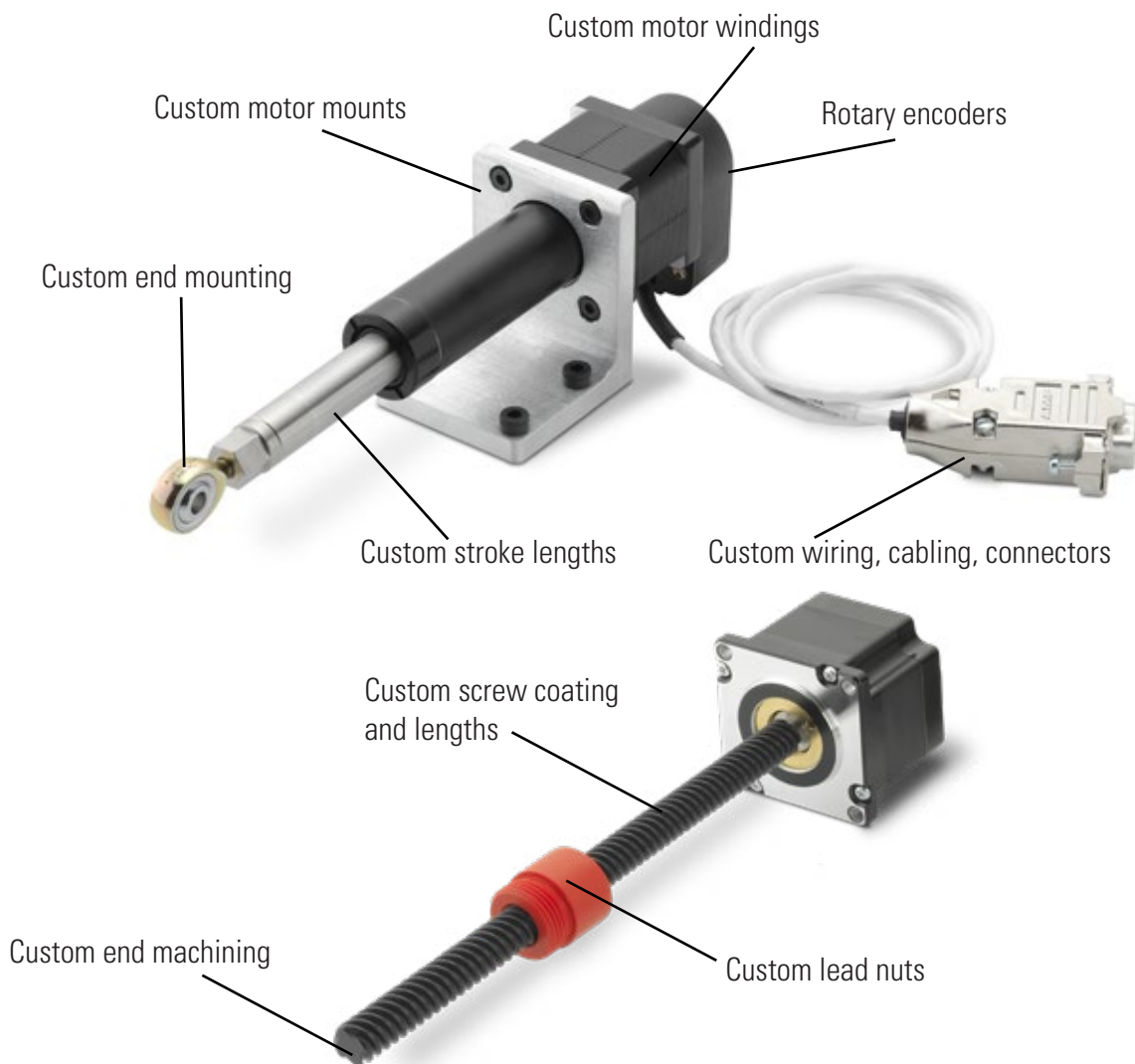

Let's Get Started

Call today and let's talk about how our vast offering of standard, modified standard and custom solutions can deliver the optimal balance of performance, life and installed cost for you. Global contact information is available at www.thomsonlinear.com/cs.

Custom lead screw end machining and MLA end mounting

Thomson standard end machining and end mounting offerings serve a wide variety of needs and applications. We can also accommodate special requests, including:

- Male or female threaded ends to your specified thread and pitch
- Custom-machined journals and ring groove
- Hex or square ends
- Keyways and cross holes
- Most custom end-machining and end-mounting options can be accommodated. Contact Thomson with a drawing to get started.

Custom lead nuts

For MLS configurations, Thomson can create a custom lead nut to your specifications. Simply contact us with a drawing, and we will work to meet your needs.

Custom motor mounts

A custom mount can provide increased design flexibility with regards to motor mounting in your assembly. Contact us if you'd like a special flange solution, and we'll work to create a mount to your exact dimensional requirements.

Rotary encoders

Applications often require extra information in the form of encoder feedback. Thomson has experience integrating encoders into our stepper motor linear actuator assemblies, and our selection delivers real-time information about position, speed and direction. Encoders can be seamlessly pre-assembled onto the backs of motors on Thomson ML products.



Custom wiring, cabling and connectors

To optimize integration of our motors in your assembly, Thomson offers custom connection methods, including:

- Flying wire leads or custom connectors
- Twisting wire leads to your specification
- Heat shrink or expandable tubing
- Custom cable housings
- Contact Thomson with your custom wiring requirements



Custom lead screw and MLA stroke lengths

Depending on the configuration, Thomson can provide a wide variety of lead screw and stroke lengths. For recommend maximums, see individual motor sections. For anything outside of these ranges, contact Thomson.

Screw coating

On MLS configurations requiring dry and maintenance-free lubrication, Thomson can offer PTFE coating.

Less common applications (MLA)

Consult Thomson engineering for assistance in any applications with the following characteristics:

- Motor speeds >500 rpm
- Side loads >10% and/or side loads at fully extended position for MLA configurations
- Vertically oriented configurations with a high load and lead
- Zero tolerance of grease leaking out of front seal in MLA configurations



Product Selection Overview

The successful integration of a stepper motor linear actuator in an application is primarily dependent on the screw alignment and subsequent screw runout. If incorrectly mounted, a lead screw assembly will have significantly reduced system life and may be noisy or inaccurate. Thomson methodically straightens all screws prior to assembly to minimize vibration and runout. The Taper-Lock coupling method also was designed to provide a concentric interface and optimize alignment. Proper alignment, end support configuration and lead nut selection are important factors to achieve a well designed installation that will exceed expectations.

1. Select Stepper Motor Linear Actuator Configuration

Determine which of the configurations – rotating screw (MLS), rotating nut (MLN) or actuator (MLA) – the application requires. See pages 6-7 for application examples.

2. Select Motor Size

Select the appropriate size based on desired performance, motor frame size, etc. Thomson offers five base models (MLx08, MLx11, MLx14, MLx17 and MLx23) in various motor windings, linear travels and load capacities.

3. Select Lead Screw Configuration and End Machining or End Mounting

For MLS or MLN, select the lead screw diameter and length with regard to the required stroke of the application and the type of end machining the screw requires. For MLA, select desired lead or travel per step, stroke length and end mounting.

4. Select Nut

For rotating screw (MLS) configurations, choose between various nut mounting styles, materials, and backlash options. Rotating nut (MLN) configurations as default always come in a high performance material, standard backlash nut. As a default, all MLA configurations come with a standard backlash and performance material nut.

5. Mount the Stepper Motor Linear Actuator

Mount the unit into your assembly. For MLA, use the end mounting installation guidelines shown below.

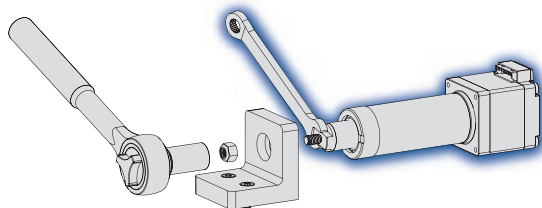

When installing your load to the end mount of an MLA assembly, always use the dedicated flats to prevent over-torquing and damaging the actuator's internal components.

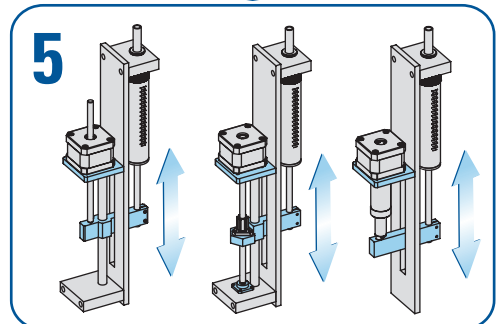
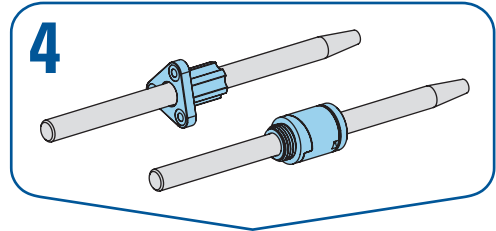
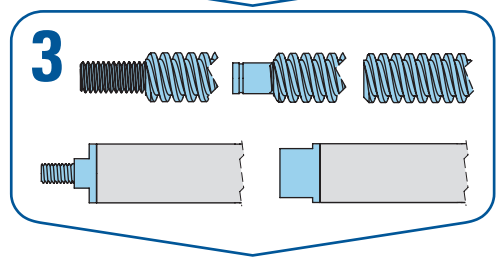
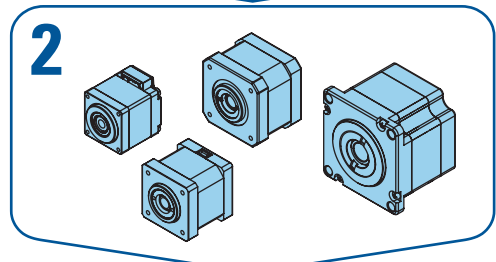
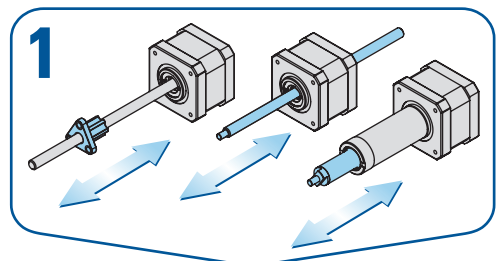

Wiring and Connectors

Thomson offers standard wiring and connector pin-outs (shown below). However, if you have unique application requirements such as a specific mating connector you'd like to easily plug into, we also offer custom wiring and connectors to match your needs. Just contact us with your request, and we'll find a solution.

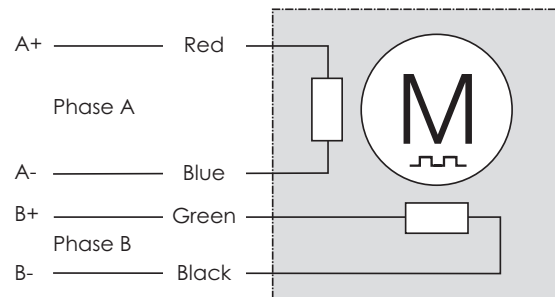

MLx08

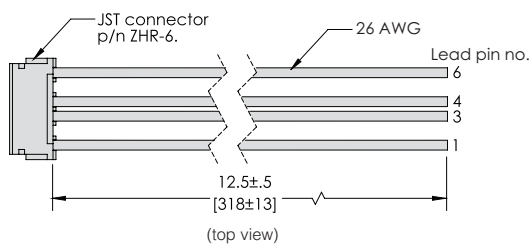

Pin	Phase	Color
1	A+	Red
2	NA	NA
3	A-	Blue
4	B+	Green
5	NA	NA
6	B-	Black

MLx11

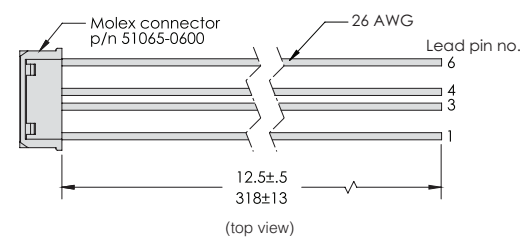

Pin	Phase	Color
1	B-	Black
2	NA	NA
3	B+	Green
4	A-	Blue
5	NA	NA
6	A+	Red

MLx14, MLx17 and MLx23

Lead Color	Phase
Red	A+
Blue	A-
Green	B+
Black	B-

- MLx14, MLx17 and MLx23 motors come standard with flying leads
- 26 AWG lead wires for MLx14
- 22 AWG lead wires for MLx17 and MLx23
- Other lead wire gauges available - contact Thomson for more details



Glossary

Accuracy	A measurement of precision. Perfect accuracy, for example, means advancing a lead nut linearly one inch from any point on a screw will always require the exact same number of revolutions.
Axial Load	A load passing through the center axis of the lead screw.
Backdrive	Application of a force on a lead nut to cause rotation of the screw; in essence, converting linear to rotary motion.
Backlash	The axial or radial free motion between the lead nut and lead screw; a measure of system stiffness and repeatability.
Bipolar Motor	Motor with two phases and a single winding per phase (4 lead wires). All Thomson standard stepper motors are bipolar.
Chopper Drive	A constant current stepper motor drive that operates by quickly cycling power on and off, or “chopping.”
Column Load	Column loading is the compression load on the screw. This load has a tendency to buckle the screw and is dependent on screw diameter, screw length and type of mounting.
Concentricity	Condition where the median points of two or more radially-disposed features are congruent with the axis (or center point).
Critical Speed	The condition where the rotary speed of the assembly sets up harmonic vibrations. These vibrations are the result of shaft diameter, unsupported length, type of bearing support, lead nut mounting method and/or screw rpm. Vibrations may also be caused by a bent screw or faulty installation alignment.
Drag Torque	The amount of torque required to drive the unloaded lead screw.
Driving Torque	The amount of effort required to turn the lead screw and move the load.
Dynamic Load	Load applied to stepper motor linear actuator assembly while in motion.
Efficiency (Lead Screw)	Expressed as a percentage, the ability of a lead screw assembly to convert torque to thrust with minimal mechanical loss. Thomson lead screws range in efficiency from 35 to 85%.
Efficiency (Motor)	Expressed as a percentage, the motor’s ability to turn electrical energy into mechanical energy with minimal thermal loss. Thomson stepper motors range in efficiency from 65 to 90%.
End Fixity or End Bearing Support	How the ends of the lead screw are fixed or supported.
Holding Torque	Torque required to rotate motor shaft while all coils are fully energized with a steady state DC current.
Inertia	The level of rotational resistance of a lead screw or shaft.
Lead	The axial distance a screw travels during one revolution. If thread is 1 start, lead = pitch.
Microstepping	Dividing the motors natural full step by smaller increments. Example: 1.8 ° step motor microstepped at 64x will mean that 1 pulse is now $1.8^\circ/64 = 0.028^\circ$.
Perpendicularity	Condition of a surface, center plane, or axis at a right angle to a plane or axis.
Pitch	Distance measured between adjacent threads of the lead screw - if thread is 1 start, then pitch = lead.
Pulse Rate	The number of pulses per second (pps) applied to the windings of the motor. 1 pulse = 1 step.
Repeatability	A measure of constancy that is directly related to axial backlash. Higher backlash equates to lower repeatability and may be corrected by preloading the lead nut if required.
Resolution	The linear distance the stepper motor linear actuator will actuate the lead nut or screw per input pulse.
Resonance	Vibration occurring when a mechanical system operates within an unstable range.
Runout	Composite tolerance used to control the functional relationship of one or more features of a part to an axis.
Side Load (Radial)	A load applied perpendicular to the lead screw axis. Not recommended for lead screw applications as it will reduce functional life.
Static Load	Static load is the maximum non-operating load capacity above which failure of the motor and/or lead nut occurs.
Straightness	Condition where an element of a surface, or an axis, is in a straight line.
Stroke	The maximum length of extension of a lead nut on the lead screw.
Thrust Force or Thrust Load	Thrust load is loading parallel to and concentric with the centerline of the screw which acts continuously in one direction. Thrust loading is the proper method of attaching the load to the lead screw assembly.
Travel/Step or Travel Rate	The linear translation of a lead nut or screw for one full step of the motor.

Notes

USA, CANADA and MEXICO

Thomson
203A West Rock Road
Radford, VA 24141, USA
Phone: 1-540-633-3549
Fax: 1-540-633-0294
E-mail: thomson@regalrexnord.com
Literature: literature.thomsonlinear.com

EUROPE

United Kingdom
Thomson
Office 9, The Barns
Caddsdow Business Park
Bideford, Devon, EX39 3BT
Phone: +44 1271 334 500
E-mail: thomson.europe@regalrexnord.com

Germany
Thomson
Nürtinger Straße 70
72649 Wolfschlügen
Phone: +49 7022 504 403
Fax: +49 7022 504 405
E-mail: thomson.europe@regalrexnord.com

France
Thomson
Phone: +33 243 50 03 30
E-mail: thomson.europe@regalrexnord.com

Italy
Thomson
Via per Cinisello 95/97
20834 Nova Milanese (MB)
Phone: +39 0362 366406
Fax: +39 0362 276790
E-mail: thomson.italy@regalrexnord.com

Sweden
Thomson
Bredbandsvägen 12
29162 Kristianstad
Phone: +46 44 590 2400
Fax: +46 44 590 2585
E-mail: thomson.europe@regalrexnord.com

ASIA

Asia Pacific
Thomson
E-mail: thomson.apac@regalrexnord.com

China
Thomson
Rm 805, Scitech Tower
22 Jianguomen Wai Street
Beijing 100004
Phone: +86 400 606 1805
Fax: +86 10 6515 0263
E-mail: thomson.china@regalrexnord.com

India
Kollmorgen – Div. of Altra Industrial Motion
India Private Limited
Unit no. 304, Pride Gateway, Opp. D-Mart,
Baner Road, Pune, 411045
Maharashtra
Phone: +91 20 67349500
E-mail: thomson.india@regalrexnord.com

South Korea
Thomson
3033 ASEM Tower (Samsung-dong)
517 Yeongdong-daero
Gangnam-gu, Seoul, South Korea (06164)
Phone: + 82 2 6001 3223 & 3244
E-mail: thomson.korea@regalrexnord.com

SOUTH AMERICA

Brazil
Thomson
Av. João Paulo Ablas, 2970
Jardim da Glória - Cotia SP - CEP: 06711-250
Phone: +55 11 4615 6300
E-mail: thomson.brasil@regalrexnord.com



BIBUS[®]
SUPPORTING YOUR SUCCESS

BIBUS SK, s.r.o
Trnavská 31, SK-94 901 Nitra

Tel.: 037/ 7777 911 Email: sale@bibus.sk
Fax.: 037/ 7777 999 <http://www.bibus.sk>

www.thomsonlinear.com

Motorized_Lead_Screw_BRUK-0012-10 | 20230726SK
Specifications are subject to change without notice. It is the responsibility of the product user to determine the suitability of this product for a specific application. All trademarks property of their respective owners.
©2023 Thomson Industries, Inc.



Linear Motion. Optimized.[™]

A REGAL REYNORD BRAND