

# Stromag Storm Brakes



# Stromag

Founded in 1932, Stromag has grown to become a globally recognized leader in the development and manufacture of innovative power transmission components for industrial drivetrain applications. Stromag engineers utilize the latest design technologies and materials to provide creative, energy-efficient solutions that meet their customer's most challenging requirements.

Stromag's extensive product range includes flexible couplings, disc brakes, limit switches, an array of hydraulically, pneumatically, and electrically actuated brakes, and a complete line of electric, hydraulic and pneumatic clutches.

Stromag engineered solutions improve drivetrain performance in a variety of key markets including energy, off-highway, metals, marine, transportation, printing, textiles, and material handling on applications such as wind turbines, conveyor systems, rolling mills, agriculture and construction machinery, municipal vehicles, forklifts, cranes, presses, deck winches, diesel engines, gensets and stage machinery.



VISIT US ON THE WEB AT **STROMAG.COM**

# Altra Motion

Altra is a leading global designer and producer of a wide range of electromechanical power transmission and motion control components and systems. Providing the essential control of equipment speed, torque, positioning, and other functions, Altra products can be used in nearly any machine, process or application involving motion. From engine braking systems for heavy duty trucks to precision motors embedded in medical robots to brakes used on offshore wind turbines, Altra has been serving customers around the world for decades.

Altra's leading brands include **Ameridrives**, **Bauer** Gear Motor, **Bibby** Turboflex, **Boston** Gear, **Delevan**, **Delroyd** Worm Gear, **Deltran**, **Formsprag** Clutch, **Guardian** Couplings, **Huco**, **Jacobs** Vehicle Systems, **Kilian**, **Kollmorgen**, **Lamiflex** Couplings, **Marland** Clutch, **Matrix**, **Nuttall** Gear, **Portescap**, **Stieber**, **Stromag**, **Svendborg** Brakes, **TB Wood's**, **Thomson**, **Twiflex**, **Warner** Electric, **Warner** Linear and **Wichita** Clutch

VISIT US ON THE WEB AT **ALTRAMOTION.COM**



## CONTENT

---

<b>RBS RAIL CLAMPS</b>	<b>4</b>
<b>RRBS RETRACTABLE RAIL BRAKES</b>	<b>6</b>
<b>RPS RAIL PRESS BRAKES</b>	<b>8</b>
<b>RPS-SA RAIL BRAKES - SELF ADJUSTING</b>	<b>10</b>
<b>WBES WHEEL BRAKE ELECTRICAL</b>	<b>12</b>

### RBS RAIL BRAKES



## RBS Rail Brakes prevent the crane from uncontrolled motion along the rail in case of sudden bursts of wind

RBS rail brakes are designed to apply friction forces on both sides of a rail. They are spring set and hydraulically released.

They ride above the rail with two flangeless rollers which continuously make contact with the rail. Hardened guides, attached to the cylindrical roller frame, protect serrated shoes from hitting the rail. As the clamp mechanism can float laterally with very little friction, guides wear is very low. This increases rail brakes safety and reliability and reduces the maintenance costs.

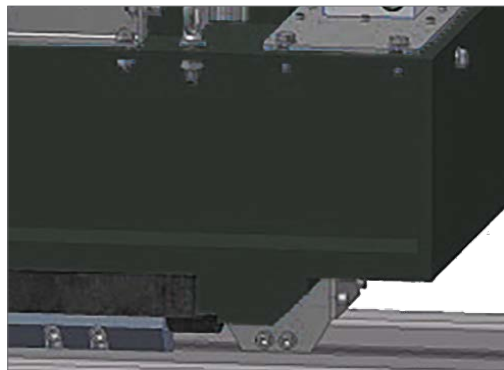

#### Applications

- Ship to shore cranes
- Automated stacking cranes
- Rail-mounted gantry cranes
- Shiploaders
- Rail-mounted material handling equipment

#### Benefits

- Floating mechanism allowing compensation of horizontal  $\pm 30\text{mm}$  and vertical  $\pm 30\text{mm}$
- Roller and guide assembly can be easily lifted out of the clamp body for ease maintenance
- No need for lubrication point for the floating mechanism
- Rail clamp shoes retract beyond the guide frames and are protected from hitting the side of a rail during crane traversing
- Robust levers made from quality structural steel
- Frame painted with marine grade painting system for superior corrosion protection
- Hand pump for manual hydraulic release of the rail brake if power is not available

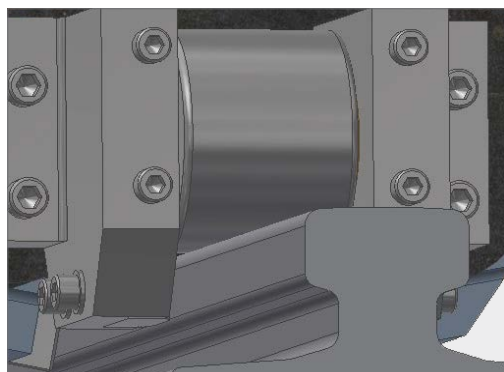

### TECHNICAL DATA

- Springs application
- Hydraulic release
- Integrated Hydraulic Power Unit
- Stainless steel removable cover with inspection doors
- IFM proximity switch for opening monitoring
- Prewired junction box
- Hand pump for manual release
- Adjustable clamp by flow control valve
- Relief valve pressure set at 125% above the operating pressure

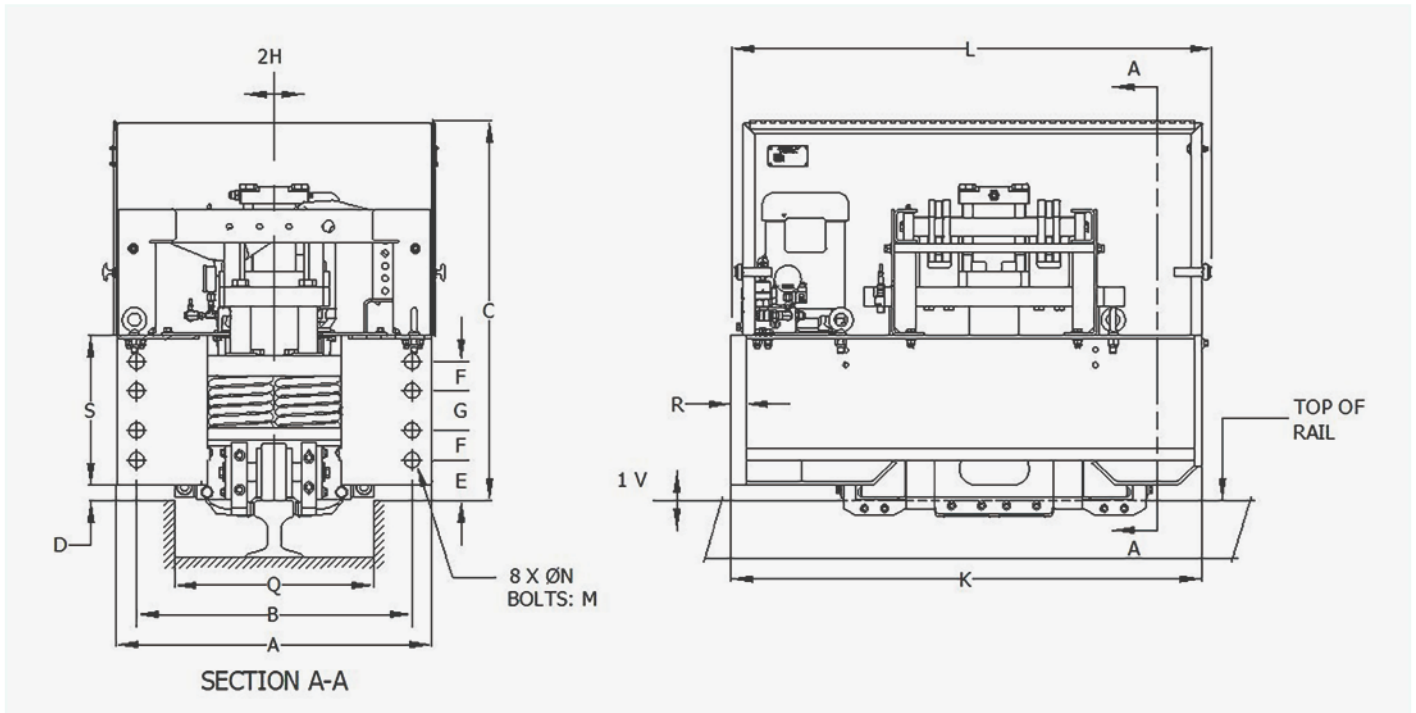

**1V** Vertical Rail Deviation (Float)  $\pm 25\text{mm}$  relative to Rail Clamp enclosure at full rated capacity.  
**2H** Horizontal Rail Position Deviation (Float)  $\pm 25\text{mm}$  relative to Rail Clamp enclosure at full rated capacity.

MODEL	HOLDING CAPACITY (kN)	A	B	C	D	E	F	G	K	L	M	N	Q	R	S
RBS-HS-50-SF	50	578	530	687	40	85	50	65	896	916	M20	22	260	22	254
RBS-HS-100-SF	100														
RBS-HS-150-SF	150														
RBS-HS-200-SF	200	711	635	735		85	65	90	885	909	M27	29	340	25	318
RBS-HS-250-SF	250														
RBS-HS-300-SF	300														
RBS-HS-350-SF	350	800	700	816		105	75	100	1099	1118	M36	39	360	32	380
RBS-HS-400-SF	400														
RBS-HS-450-SF	450														
RBS-HS-500-SF	500	850	730	1050		120	110	170	1200	1230	M42	45	400	46	530
RBS-HS-600-SF	600														
RBS-HS-800-SF	800														
RBS-HS-900-SF	900														
RBS-HS-1000-SF	1000														



# RRBS RETRACTABLE RAIL BRAKES

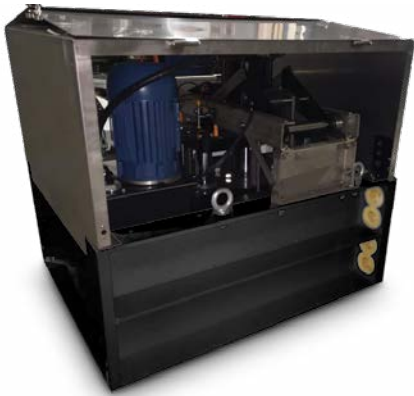

## RRBS Retractable Rail Brakes are the obvious choice especially for high speeds machines

RRBS rail brakes are designed to clamp on both sides of a rail. They are spring set and hydraulically released.

They are designed to release and retract fully from the rail head. This eliminates mechanical guiding means at rail level. So there is no wear and tear to guide means, brake shoes or the rails head itself.

The RRBS rail clamp mechanism is top supported and float laterally with ease. All the features of these brakes allow reliability and low maintenance.

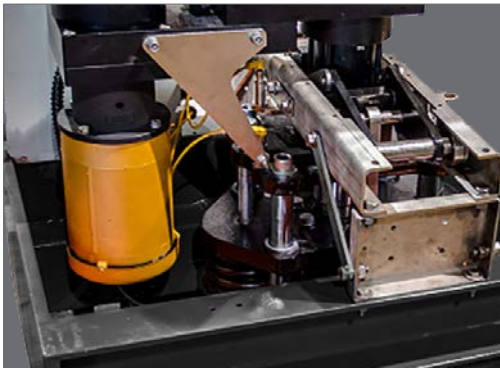

### Applications

- Ship to shore cranes
- Automated stacking cranes
- Rail-mounted gantry cranes
- Shiploaders
- Rail-mounted material handling equipment

### Benefits

- No mechanical guiding means at rail level at any speed: paramount for high speed, modern cranes
- Floating mechanism allowing compensation of horizontal  $\pm 30\text{mm}$  and vertical  $\pm 25\text{mm}$  (up to  $\pm 40\text{mm}$  upon request)
- No need for lubrication point for the floating mechanism
- Serrated shoes protected from hitting the rails sides for less wear
- Hydraulic cylinder easily removable for quick maintenance and replacement
- Clamp release, positioning and reserve stroke monitoring by proximity switches
- Stainless steel removable cover with inspection doors



### TECHNICAL DATA

- Springs application
- Hydraulic release
- Integrated Hydraulic Power Unit
- Stainless steel removable cover with inspection doors
- IFM proximity switch for opening monitoring
- Prewired junction box
- Hand pump for manual release
- Adjustable clamp by flow control valve
- Relief valve pressure set at 125% above the operating pressure

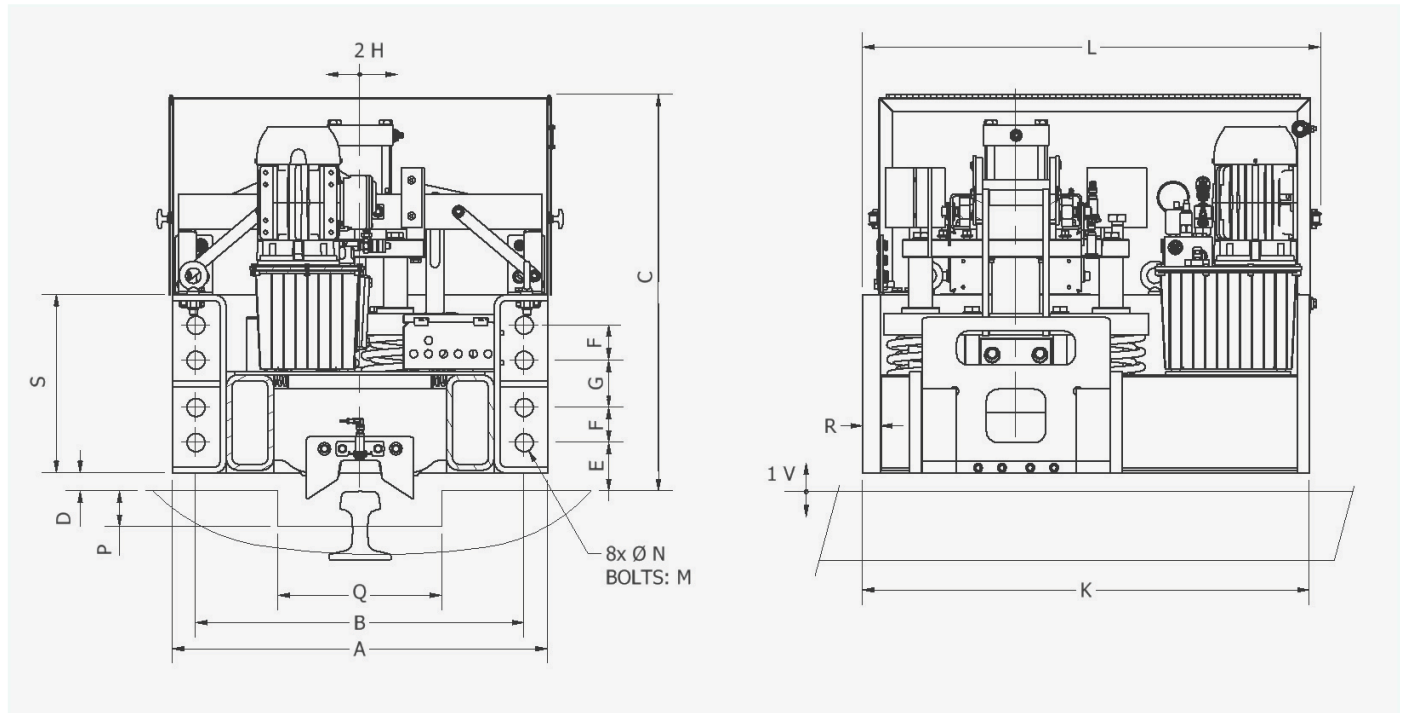

**1V** Vertical Rail Deviation (Float)  $\pm 25\text{mm}$  relative to Rail Clamp enclosure at full rated capacity.

**2H** Horizontal Rail Position Deviation (Float)  $\pm 25\text{mm}$  relative to Rail Clamp enclosure at full rated capacity. Larger floats available upon request.

**P\*** & **Q\*** Dimensions are subject to a specific rail size.

MODEL	HOLDING CAPACITY (kN)	A	B	C	D	E	F	G	K	L	M	N	Q*	P*	R	S
RRBS-HS-50-SF	50	578	530	735	30	75	50	65	710	735	20	22	280	65	22	254
RRBS-HS-100-SF	100															
RRBS-HS-150-SF	150															
RRBS-HS-200-SF	200	705	635	775	40	85	65	90	860	895	27	29	340	75	25	310
RRBS-HS-250-SF	250															
RRBS-HS-300-SF	300															
RRBS-HS-350-SF	350	800	700	860	40	105	75	100	950	976	36	39	360	75	40	380
RRBS-HS-400-SF	400															
RRBS-HS-450-SF	450															
RRBS-HS-500-SF	500	850	730	1050	40	120	110	170	1200	1230	39	42	380	75	46	540
RRBS-HS-600-SF	600															
RRBS-HS-800-SF	800															
RRBS-HS-900-SF	900	900	780	1050	40	115	100	180	1400	1430	42	45	400	75	46	530
RRBS-HS-1000-SF	1000															
RRBS-HS-1200-SF	1200															

# RPS RAIL PRESS BRAKES



## RPS Rail Press Brakes apply spring force on the top of the rail while permitting a large rail deviation

RPS rail brakes use the weight of the crane in the braking process and provide the braking force along the rail. They are spring set and hydraulically released. Once released, the brake hangs above the rail at a pre-designed clearance. Actual braking capacity depends on the applied force and applicable coefficient of friction (different for static and dynamic braking). RPS brakes are parking brakes designed to apply when a crane comes into a full stop position.

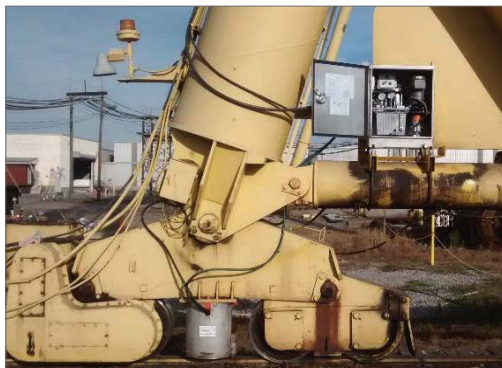

### Applications

- Ship to shore cranes
- Automated stacking cranes
- Rail-mounted gantry cranes
- Shiploaders
- Rail-mounted material handling equipment

### Benefits

- Permit large variations of the rail height by means of a longer spring stroke and provide a balanced braking force / stroke curve
- Serrated shoes fully protected from hitting the top of the rail for less wear and tear
- Longer lasting springs for reduced maintenance
- Ultimate gust wind protection for the operator and the crane
- Flow control valve installed on the brake for controlled setting time
- Proximity switch for release indication
- Brake shoes easily removed and replaced
- Made with high quality structural steel
- Standard frame painting total coat min. 200-275  $\mu\text{m}$





### TECHNICAL DATA

- Springs application
- Hydraulic release
- Proximity switch

- SRPS Static Rail Press: 150 kN, 220 kN, 300 kN
- DRPS Dynamic Rail Press: 120 kN, 180 kN, 240kN

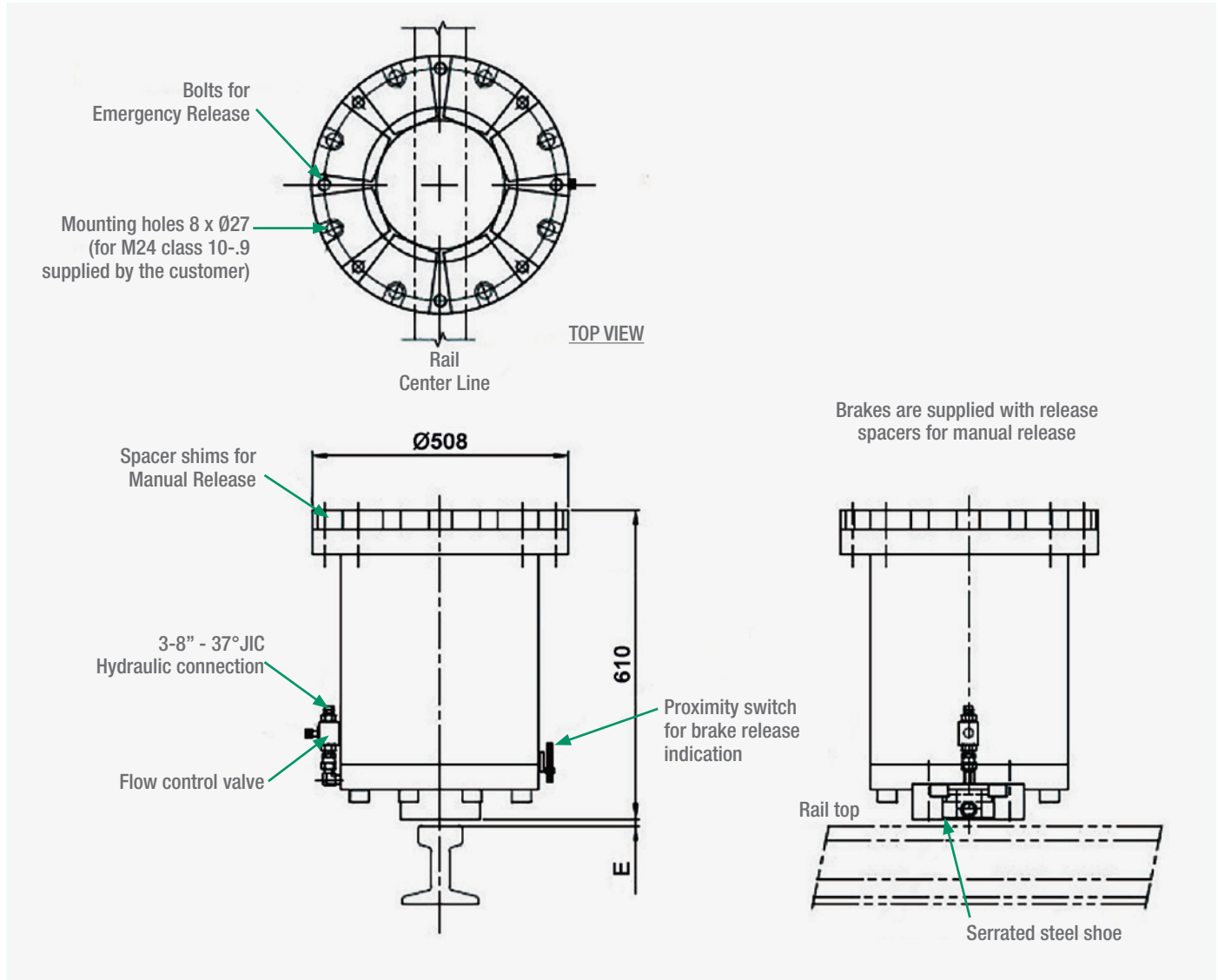

### SRPS -220 BRAKING FORCE at various stroke extensions

Shoe extension: E mm	Applied force kN	Braking force kN
<b>BRAKE RELEASED</b>	0	595
<b>BRAKE APPLIED</b>	10	500
	16	439
	20	396
	30	278
	35	214

Ex.: **Nominal holding force** = 220 kN @ 16mm shoe extension & 0.5 Coeff. of Friction  
 Actual achievable brake force depends on available crane weight. Thus can be affected by brake mounting position and wind loading of crane.

# RPS-SA RAIL BRAKES - SELF ADJUSTING



## RPS-SA Rail Brakes compensate high variations of rail height, they are automatically adjusted before braking

RPS-SA rail brakes are completely spring set brakes.

These brakes apply spring force on the top of the rail, they use the weight of the crane in the braking process and provide the friction force along the rail.

Two step braking ensures that the shoe is in contact with the rail before spring force is applied.

The design of these brakes allows a small and consistent spring stroke for spring durability.



### Applications

- Ship to shore cranes
- Automated stacking cranes
- Rail-mounted gantry cranes
- Shiploaders
- Rail-mounted material handling equipment

### Benefits

- Compensation of  $\pm 19$  mm of rail height variations with full rated capacity
- All components are fully enclosed in a sealed housing
- No release shims, 3 methods for emergency release: HPU hand pump Internal jacking screws & shoe removal - External hand pump & screws
- Serrated shoes protected from hitting the rails sided for less wear
- Compact design: Low height allows retrofitting for adapter flanges
- Proximity switch for release indication
- Brake shoes easily removed and replaced
- Made with high quality structural steel

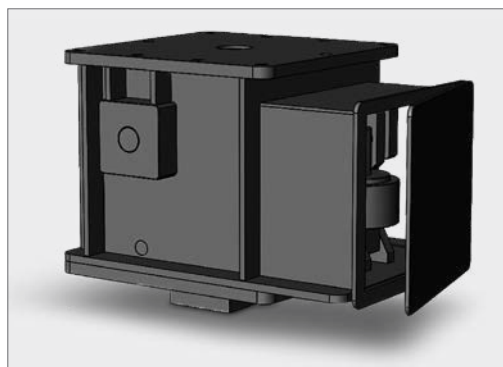

### TECHNICAL DATA

- Springs application
- Hydraulic release
- Proximity switch for release monitoring

- SRPS-SA Static Rail Press: 150 kN & 220 kN
- DRPS-SA Dynamic Rail Press: 120 kN & 180 kN

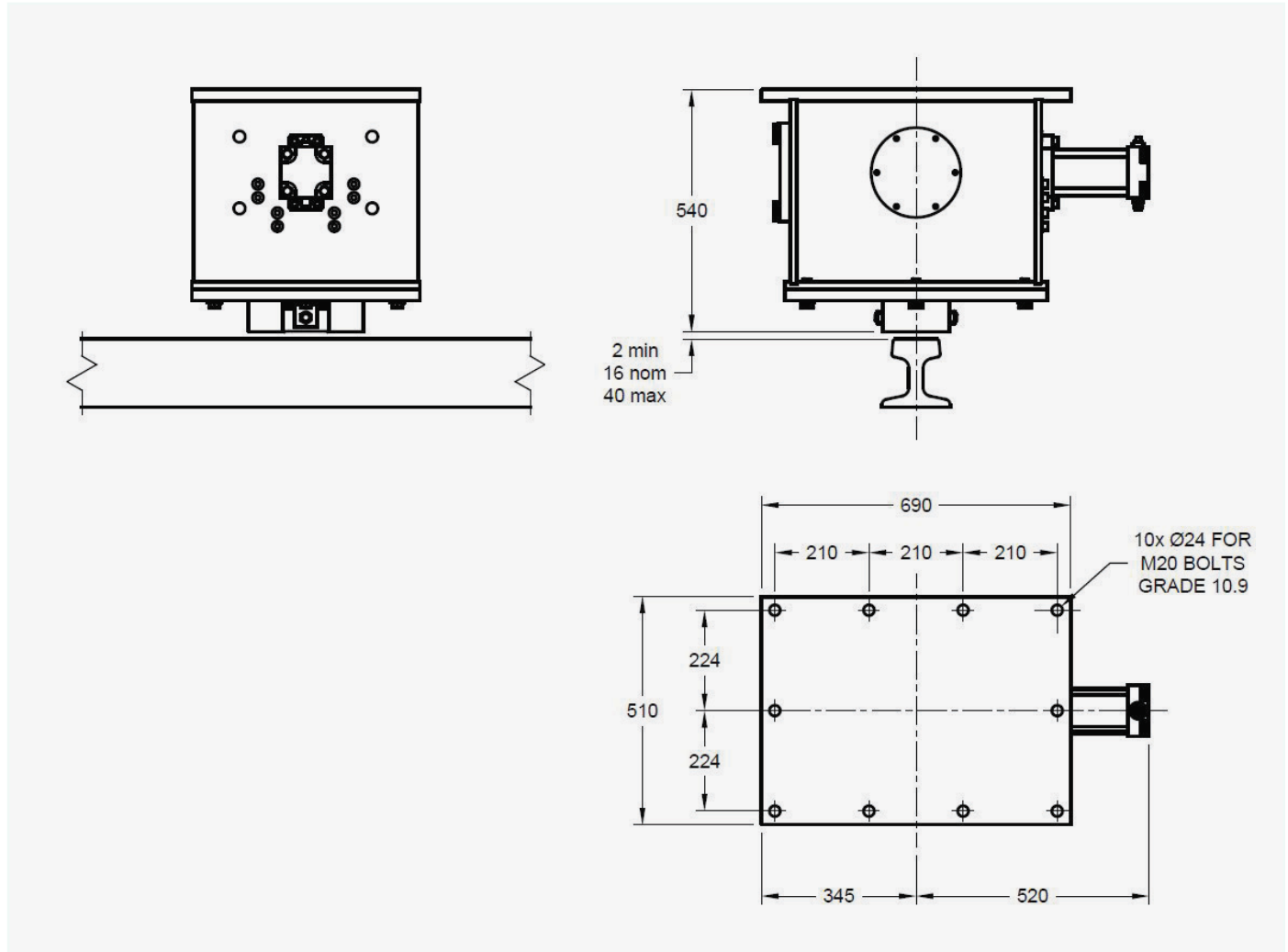

### RPS-SA-220 BRAKING FORCE at various stroke extensions

	Shoe extension: E mm	Applied force kN	Braking force kN
<b>BRAKE RELEASED</b>	0	470	235
<b>BRAKE APPLIED</b>	2	450	225
	8	445	222
	16	440	220
	28	420	210
	40	410	205

Ex.: **Nominal holding force** = 220 kN @ 16mm shoe extension & 0.5 Coeff. of Friction  
 Actual achievable brake force depends on available crane weight. Thus can be affected by brake mounting position and wind loading of crane.

# WBES WHEEL BRAKES ELECTRICAL



## WBES Wheel Brakes are parking and safety devices that can be used as dynamic brakes in case of emergency

WBES Wheel Brakes are spring applied, with braking force generated by the multiplied forces of springs. Mounted on the idler wheels of rail mounted equipment, they work in conjunction with the existing gantry motor brakes to prevent movement in case of wind microbursts. They are electrically released. An electro-mechanical actuator retracts the brake pads off the wheel and an actuator holding brake is engaged to hold the spring load. Electric actuator replaces hydraulic power unit or thruster and eliminates the possibility of hydraulic leakage.



### Applications

- Ship to shore cranes
- Automated stacking cranes
- Rail-mounted gantry cranes
- Shiploaders
- Rail-mounted material handling equipment

### Benefits

- Simple and compact design
- No hydraulic components, so no environmental or fire liabilities
- Equipped with shoe alignment device
- Release nut for mechanical release
- Proximity switch for release monitoring
- Replacement of the brake pad, made from asbestos-free composite, without brake removal from the crane
- Spring pack designed for long life
- On all pivot points: stainless steel pins and self-lubricating bushings
- Means for adjusting the air gap
- Left hand / right hand orientation
- Made from good quality structural steel



### TECHNICAL DATA

- Springs application
- Electrical release
- Parking brake, can be used as dynamic brake in an emergency situation
- Proximity switch for release monitoring
- For wheel diameter from 500 mm to 1200 mm and wheel width from 140 mm to 240 mm
- Available horizontal float:  $\pm 6$ mm
- Shoe to wheel flange clearance: 1 mm per side (must be adjusted for wear on regular basis)
- Maximum pad wear limits: 6 mm per side
- Main power voltage: AC / DC voltage available
- Control voltage: single phase AC or DC available
- Operating temperature: -20 to 70° C

MODEL	BRAKING FORCE kN
WBES-30	30
WBES-60	60
WBES-90	90
WBES-120	120

Braking force calculated using theoretical coefficient of friction  $\mu=0.4$

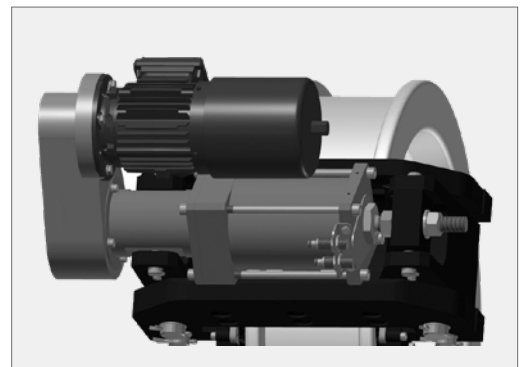
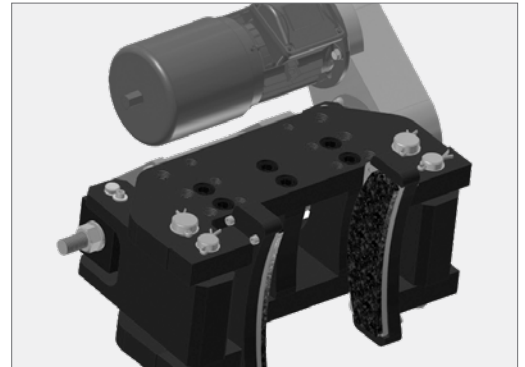





# Premier Industrial Company Leading Brands

## OTHER PRODUCT SOLUTIONS FROM **ALTRA MOTION**

Our comprehensive product offerings include various types of clutches and brakes, overrunning clutches, engineered bearing assemblies, gearing and gear motors along with linear motion products, belted drives, couplings, limit switches, precision motors, drives & controls, miniature motors and engine braking systems. With thousands of product solutions available, Altra provides true single source convenience while meeting specific customer requirements. Many major OEMs and end users prefer Altra products as their No. 1 choice for performance and reliability.

[WWW.ALTRAMOTION.COM](http://WWW.ALTRAMOTION.COM)



### **Electric Clutches & Brakes**

Inertia Dynamics  
Matrix  
Stromag  
Warner Electric



### **Precision Motors & Automation**

Kollmorgen



### **Heavy Duty Clutches & Brakes**

Industrial Clutch  
Stromag  
Svendborg Brakes  
Twiflex  
Wichita Clutch



### **Miniature Motors**

Portescap



### **Overrunning Clutches**

Formsprag Clutch  
Marland Clutch  
Stieber



### **Linear Systems**

Thomson



### **Engineered Couplings & Universal Joints**

Ameridrives  
Bibby Turboflex  
Guardian Couplings  
Huco  
Lamiflex Couplings  
Stromag  
TB Wood's



### **Engine Braking Systems**

Jacobs Vehicle Systems



### **Gear Drives & Gear Motors**

Bauer Gear Motor  
Boston Gear  
Delroyd Worm Gear  
Nuttall Gear



### **Specialty Components**

Kilian  
Stromag  
TB Wood's

## Stromag Facilities

### Europe

#### Germany

Hansastraße 120  
59425 Unna - Germany  
+49 (0) 23 03 102 0

Clutches & Brake Couplings,  
Geared Cam Limit Switches, Discs,  
Wind Brakes

Dessauer Str. 10  
06844 Dessau-Roßlau - Germany  
+49 (0) 340 2190 0

Electromagnetic Clutches & Brakes

#### France

Avenue de l'Europe  
18150 La Guerche sur L'Aubois - France  
+33 (0)2 48 80 72 72

Disc Brakes & Drum Brakes

#### Great Britain

Amphill Road  
Bedford, MK42 9RD - UK  
+44 (0)1234 324347

Electromagnetic Clutches & Brakes,  
Industrial Caliper Brakes

### North America

#### USA

31 Industrial Park Road  
New Hartford, CT 06057 - USA  
860-238-4783

Electromagnetic Clutches & Brakes

300 Indiana Highway 212  
Michigan City, IN 46360 - USA  
219-874-5248

Couplings

2800 Fisher Rd.  
Wichita Falls, TX 76302 - USA  
940-723-3400

Geared Cam Limit Switches,  
Industrial Caliper & Drum Brakes

#### South America

Brasil  
Avenida João Paulo Ablas, 2970  
Jardim da Glória, Cotia - SP,  
06711-250 - Brasil  
+55 (11) 4615-6300

Flexible Couplings, Bearing  
Isolators, and Coupling Guards

### Asia Pacific

#### China

T40B -5, No. 1765 Chuan Qiao Road  
Pudong 201206, Shanghai - China  
Tel +86 21-60580600

Clutches & Brake Couplings, Industrial  
Caliper & Drum Brakes, Discs,  
Cam Limit Switches, Wind Brakes

#### India

Gat No.: 448/14, Shinde Vasti, Nighoje  
Tal Khed, Pune- 410 501  
+91 2135 622100

Clutches & Brake Couplings, Industrial  
Caliper & Drum Brakes, Discs,  
Cam Limit Switches, Wind Brakes



**BIBUS**  
SUPPORTING YOUR SUCCESS

BIBUS SK, s.r.o  
Trnavská 31, SK-94 901 Nitra

Tel.: 037/ 7777 911    Email: sale@bibus.sk  
Fax.: 037/ 7777 999    http://www.bibus.sk

## The Brands of Altra Motion

### Couplings

Ameridrives  
www.ameridrives.com

**Bibby Turboflex**  
www.bibbyturboflex.com

Guardian Couplings  
www.guardiancouplings.com

Huco  
www.huco.com

**Lamiflex Couplings**  
www.lamiflexcouplings.com

Stromag  
www.stromag.com

TB Woods  
www.tbwoods.com

### Linear Systems

Thomson  
www.thomsonlinear.com

### Geared Cam Limit Switches

Stromag  
www.stromag.com

### Engineered Bearing Assemblies

Kilian  
www.kilianbearings.com

### Electric Clutches & Brakes

Matrix  
www.matrix-international.com

Stromag  
www.stromag.com

Warner Electric  
www.warnerelectric.com

Deltran  
www.thomsonlinear.com

### Belted Drives

TB Wood's  
www.tbwoods.com

### Heavy Duty Clutches & Brakes

**Twiflex**  
www.twiflex.com

Stromag  
www.stromag.com

Svendborg Brakes  
www.svendborg-brakes.com

Wichita Clutch  
www.wichitaclutch.com

### Gearing & Specialty Components

Bauer Gear Motor  
www.bauergears.com

Boston Gear  
www.bostongear.com

Delevan  
www.delevan.com

Delroyd Worm Gear  
www.delroyd.com

Nuttall Gear  
www.nuttallgear.com

### Engine Braking Systems

Jacobs Vehicle Systems  
www.jacobsvehiclesystems.com

### Precision Motors & Automation

Kollmorgen  
www.kollmorgen.com

### Miniature Motors

Portescap  
www.portescap.com

### Overrunning Clutches

Formsprag Clutch  
www.formsprag.com

Marland Clutch  
www.marland.com

Stieber  
www.stieberclutch.com

Neither the accuracy nor completeness of the information contained in this publication is guaranteed by the company and may be subject to change in its sole discretion. The operating and performance characteristics of these products may vary depending on the application, installation, operating conditions and environmental factors. The company's terms and conditions of sale can be viewed at <http://www.altramotion.com/terms-and-conditions/sales-terms-and-conditions>. These terms and conditions apply to any person who may buy, acquire or use a product referred to herein, including any person who buys from a licensed distributor of these branded products.

©2019 by Stromag LLC. All rights reserved. All trademarks in this publication are the sole and exclusive property of Stromag LLC or one of its affiliated companies.