



## SINDBY PROFILES 4

## Gummi til industri og autobranchen

Hos A/S H. Sindby & Co. har vi beskæftiget os med gummiprofiler, kantlister, svampegummi og gummimåtter i knap 100 år. Vi har således en solid erfaring på området og besvarer gerne spørgsmål vedr. kemisk modstandsdygtighed, UV belastning, hårdhedsområde, trækstyrke, brudforlængelse, max. temperaturområde, slidstyrke, bestandighed o.s.v.

Alle profiler/gummiplader er lagervarer, hvis ikke andet er opgivet. Specialprofiler leveres efter ordre.

Vi løser alle opgaver - spørg os og få løsningen.

## Note

Tegningerne i dette katalog er ikke målfaste. Visse profiler i dette katalog lagerføres ikke men hjemtages kun på bestilling og ud fra mængde. Afklippede profiler tages ikke retur. Alle mål er i mm, hvis ikke andet er opgivet.

## Rubber for industry and automotive sector

At A/S H. Sindby & Co. we have been working with rubber profiles, edge profiles, sponge rubber and rubber plates for almost 100 years. We therefore have a thorough knowledge in this area and are always at your disposal if you have questions concerning chemical resistance, UV impact, hardness, tractive power, elongation at break, max. temperature range, resistance, constancy etc. All profiles / rubber plates in the catalogue are stock items unless otherwise stated. Special profiles can be supplied to order.

We can offer our assistance in all kinds of projects - ask us and we have the solution.

## Note

The drawings in this catalogue are not fixed. Certain profiles in this catalogue are not in stock and are only stocked on order. Profiles which are cut off cannot be returned. All measures are in mm unless otherwise stated.



**Keld Asp Hansen**

**Adm. direktør**  
Managing Director

## Her finder du SINDBY / Here you will find SINDBY

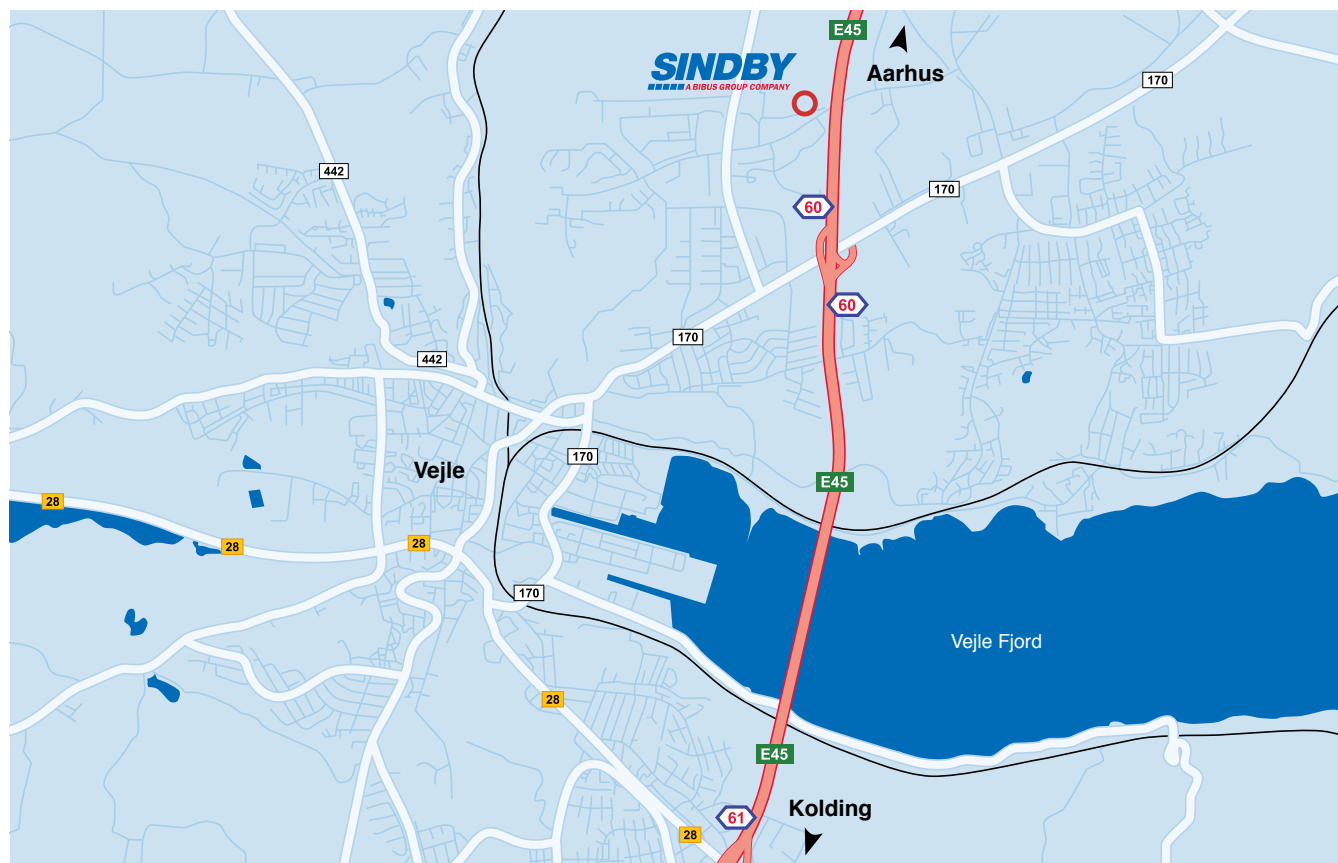

A/S H. Sindby & Co. • Edisonvej 11 • DK-7100 Vejle

<b>Kantlister / Edge trims</b> .....	2
<b>Silikonkantlister / Silicone edge trims</b> .....	14
<b>POM-profiler / POM edge trims</b> .....	16
<b>Gummisnor / Rubber cord profiles</b> .....	18
<b>Specialprofiler / Special profiles</b> .....	19
<b>Co-ekstruderede plastprofiler / Co-extruded plastic profiles</b> .....	30
<b>U-profiler / U-profiles</b> .....	33
<b>P-profiler / P-profiles</b> .....	38
<b>Rudeprofiler / Glazing sections</b> .....	40
<b>Låsekiler / Glazing sections</b> .....	43
<b>Svampegummi / Sponge rubber</b> .....	44
<b>Glasbånd / Window seals</b> .....	51
<b>Cellegummi / Cellular rubber</b> .....	52
<b>Fenderlister / Fender lists</b> .....	53
<b>Sico Trim / Sico Trim</b> .....	56
<b>Gummibuffer / Rubber buffer</b> .....	59
<b>Vibrationsdæmpere / Vibration muffler</b> .....	65
<b>Fendere / Fenders</b> .....	70
<b>Børste- og flock-lister / Brush sections</b> .....	76
<b>Lydisolering / Soundproofing</b> .....	79
<b>Kinagummiplader / Rubber sheets from China</b> .....	82
<b>Øvrige europæiskproducerede måtter / Additional mats produced in Europe</b> .....	87
<b>Gummimåtter / Rubber mats</b> .....	88
<b>Gummistropper / Rubber straps</b> .....	95
<b>Bumpers / Bumpers</b> .....	97
<b>Poliall / Poliall</b> .....	98
<b>Oppustelige tætninger / Inflatable seals</b> .....	99
<b>Portsluser og tilbehør / Dock shelters</b> .....	101
<b>Tilbehør / Equipment</b> .....	105
<b>Varenummerindex / product number index</b> .....	108
<b>Egenskaber / Properties</b> .....	113

**33.306**

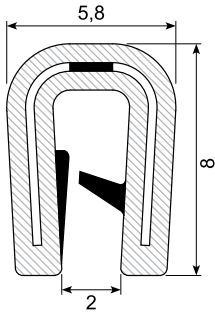

Edge trim: PVC black + bi  
Grip range: 1 - 2 mm  
Hardness: SH 78 / 65  
Insert: 15 x 0,3 mm steel

**33.409F**

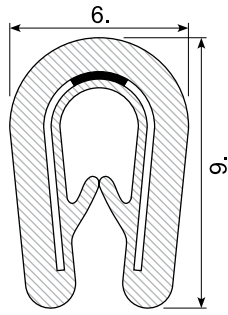

Edge trim: EPDM  
Grip range: 1 - 2 mm  
Hardness: SH 60  
Insert: Steel  
Flame retardent EN 45545

**33.409 / 33.401G**

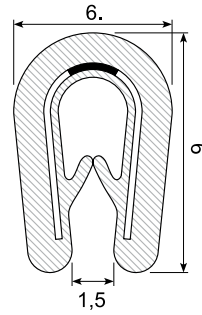

Edge trim: PVC black  
Grip range: 1 - 2 mm  
Hardness: SH 78  
Insert: 16 x 0,3 mm steel  
33.401G (grey)

**33.307A**

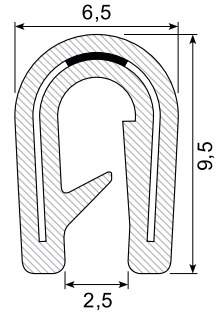

Edge trim: PVC black  
Grip range: 1 - 2 mm  
Hardness: SH 75  
Insert: 17,5 x 0,3 mm steel  
On cardboard coil

**33.410X / 33.410XG**

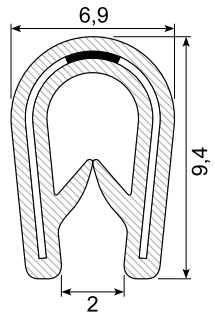

Edge trim: PVC black  
Grip range: 1 - 2 mm  
Hardness: SH 75  
Insert: 17,5 x 0,3 mm steel  
33.410XG (grey)

**33.310X**

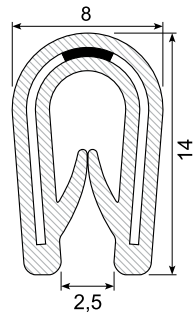

Edge trim: PVC black  
Grip range: 1 - 3 mm  
Hardness: SH 75  
Insert: 26 x 0,47 mm steel

**33.310SS**

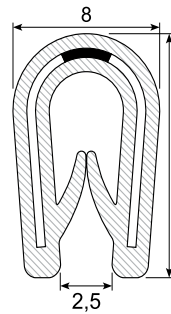

Edge trim: PVC black  
Grip range: 1 - 2,5 mm  
Hardness: SH 70 - 75  
Insert: 26 x 0,5 mm stainless steel SS 304

**33.310SS-316**

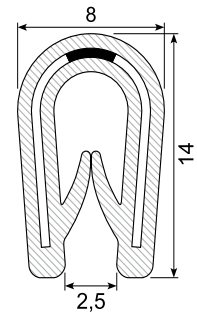

Edge trim: PVC black  
Grip range: 1 - 2,5 mm  
Hardness: SH 70 - 75  
Insert: 26 x 0,5 mm stainless steel SS 316 (acid-proof)

**33.422**

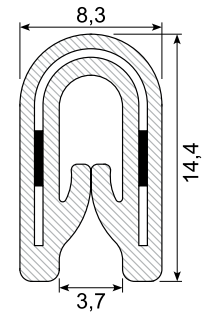

Edge trim: TPE flexible  
Grip range: 1 - 2,5 mm  
Hardness: SH 82  
Insert: 25 x 0,48 mm steel

**33.309XM**

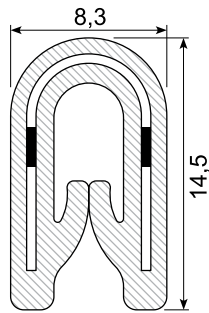

Edge trim: PVC mokka brown  
Grip range: 1 - 2,5 mm  
Hardness: SH 78  
Insert: Steel  
Current stock available

**33.003**

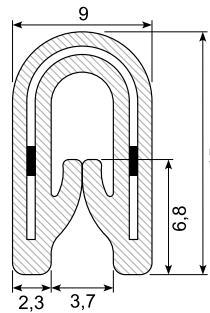

Edge trim: PVC black  
Grip range: 1 - 2,5 mm  
Hardness: SH 78  
Insert: Steel  
Current stock available

**33.418SS**

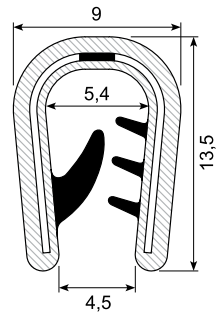

Edge trim: PVC black + bi  
Grip range: 1,5 - 3 mm  
Hardness: SH 78 / 78  
Insert: 26 x 0,5 mm stainless 304 steel

**33.308A**

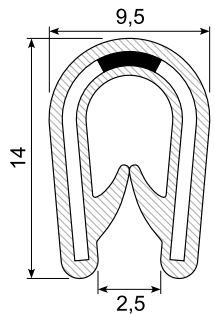

Edge trim: PVC black  
Grip range: 1 - 4 mm  
Hardness: SH 75  
Insert: 26 x 0,47 mm steel  
On cardboard coil

**33.432**

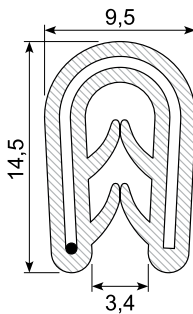

Edge trim: EPDM  
Grip range: 1 - 3 mm  
Hardness: SH 65  
Insert: 27 mm wire

**33.438**

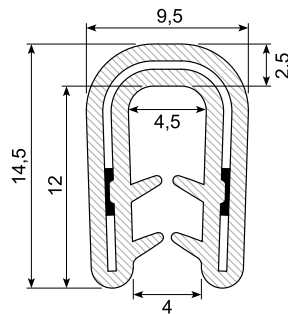

Edge trim: EPDM  
Grip range: 1,5 - 3,5 mm  
Hardness: SH 65  
Insert: 29 x 0,5 mm steel

**33.420X**

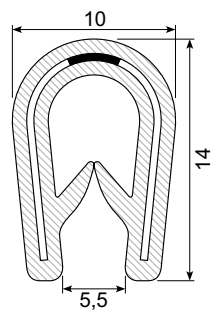

Edge trim: PVC black  
Grip range: 1 - 4 mm  
Hardness: SH 75  
Insert: 27 x 0,47 mm steel

**33.420F**

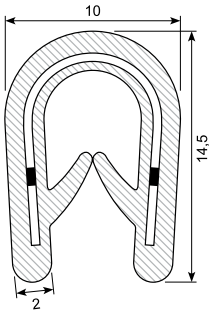

Edge trim: EPDM  
Grip range: 1 - 3 mm  
Hardness: SH 65  
Insert: 26 x 0.5 mm steel  
**Flame retardent NNF 16-101**  
Min. order: 500 m.

**33.419**

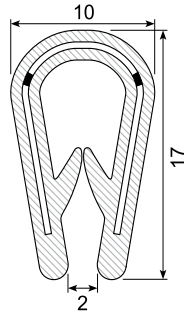

Edge trim: PVC black  
Grip range: 1 - 4 mm  
Hardness: SH 78  
Insert: 31 x 0.5 mm steel

**33.411**

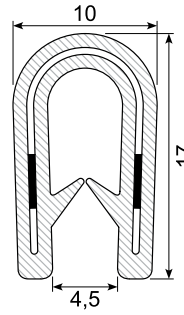

Edge trim: PVC grey  
Grip range: 2.5 - 4 mm  
Hardness: SH 78  
Insert: 29 x 0.48 mm steel

**33.411A \***

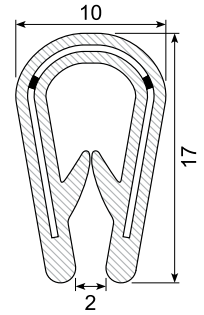

Edge trim: PVC grey  
Grip range: 1 - 4 mm  
Hardness: SH 78  
Insert: 31 x 0.5 mm steel  
Min. order: 2.000 mtr.

**33.418X**

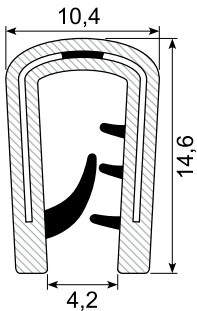

Edge trim: PVC black + bi  
Grip range: 2 - 5 mm  
Hardness: SH 75 / 75  
Insert: 26 x 0.47 mm steel  
White lips

**33.420FX**

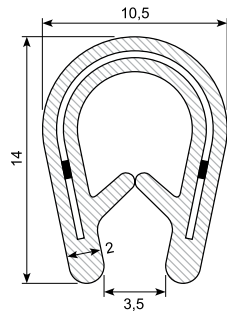

Edge trim: EPDM  
Grip range: 1 - 3 mm  
Hardness: SH 60  
Insert: 26 x 0.5 mm steel  
**Flame retardent EN 45545**

**33.425G**

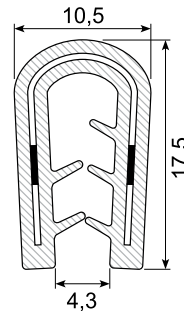

Edge trim: PVC grey  
Grip range: 3 - 4 mm  
Hardness: SH 78  
Insert: 35 x 0.48 mm steel  
Min. order: 2.000 m

**33.434**

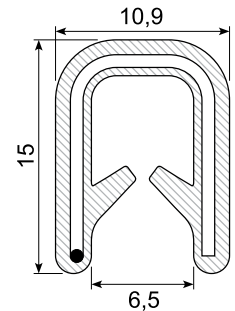

Edge trim: EPDM  
Grip range: 2 - 4 mm  
Hardness: SH 65  
Insert: 30 mm wire

**33.419A \*\***

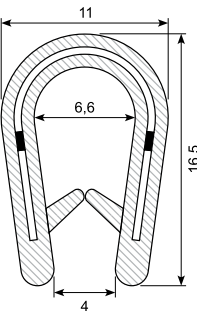

Edge trim: PVC black  
Grip range: 2 - 4 mm  
Hardness: SH 75  
Insert: 30 x 0.5 mm steel

**33.423**

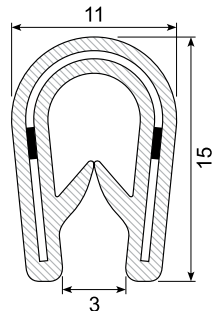

Edge trim: PVC black  
Grip range: 2.5 - 5 mm  
Hardness: SH 78  
Insert: Steel  
**Current stock available**

**33.427X**

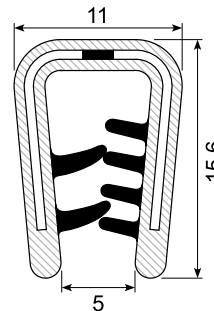

Edge trim: PVC black + bi  
Grip range: 1.5 - 4.5 mm  
Hardness: SH 75 / 75  
Insert: 30 x 0.47 mm steel  
Yellow lips

**33.094X**

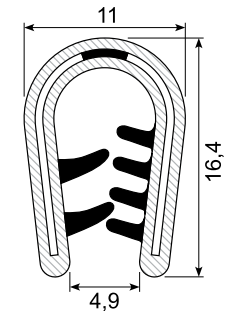

Edge trim: PVC black + bi  
Grip range: 1 - 4 mm  
Hardness: SH 75 / 75  
Insert: 30 x 0.47 mm steel  
Yellow lips

**33.1153A**

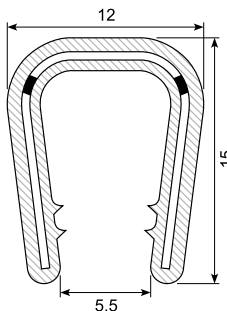

Edge trim: PVC Black  
Grip range: 6 - 8 mm  
Hardness: SH 78  
Insert: 32 mm steel

**33.1153GA**

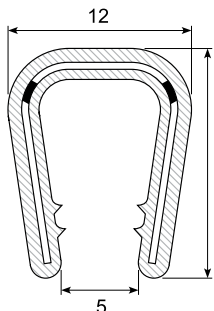

Edge trim: PVC Grey  
Grip range: 6 - 8 mm  
Hardness: SH 78  
Insert: 32 mm steel

**33.415**

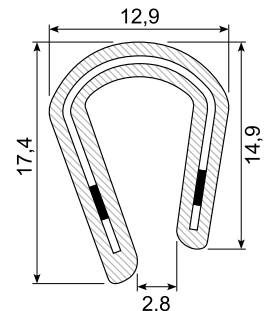

Edge trim: PVC  
Grip range: 5 - 7 mm  
Hardness: SH 78  
Insert: 29 x 0.48 mm steel

# Kantlister / Edge trims

**33.426XA**

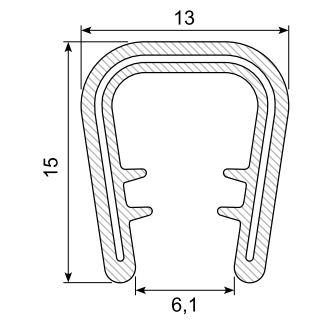

Hardness: SH 78  
Insert: 32 mm  
Min. order: 2.000 m

**33.426A**

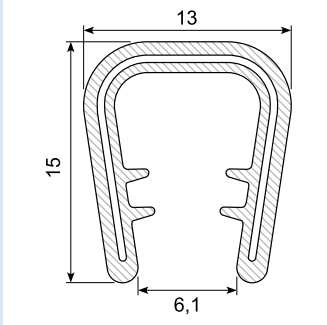

Hardness: SH 78 / 65  
Insert: 32 mm  
Min. order: 3.000 m

**33.426GA**

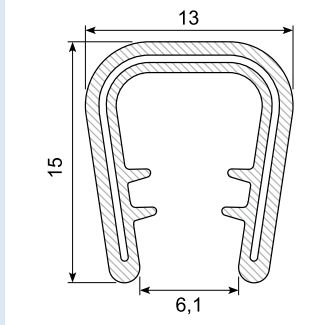

Edge trim: Grey  
Insert: 32 mm  
Min. order: 3.000 m

**33.426X**

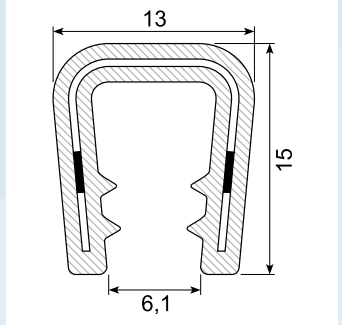

Edge trim: PVC black  
Grip range: 4,5 - 7 mm  
Hardness: SH 75  
Insert: 30 x 0,8 mm steel

**33.426**

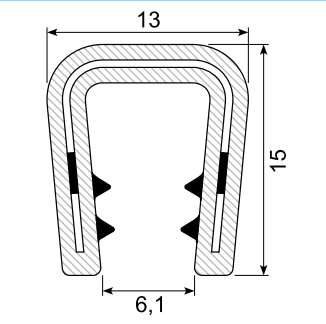

Edge trim: PVC + bi  
Grip range: 4,5 - 7 mm  
Hardness: SH 78 / 65  
Insert: 29 x 0,48 mm steel

**33.426G \***

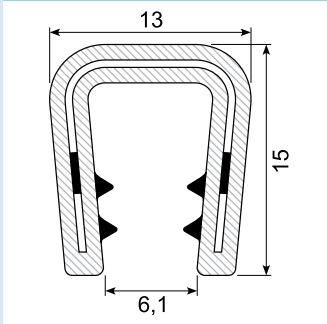

Edge trim: Grey PVC + bi  
Grip range: 4,5 - 7 mm  
Hardness: SH 78 / 65  
Insert: 29 x 0,48 mm steel  
Min. order 1.000 m

**33.433**

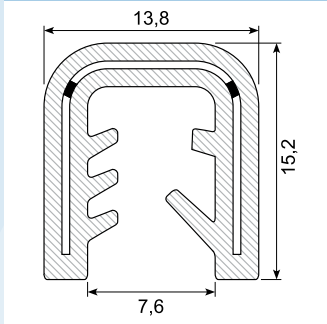

Edge trim: EPDM  
Grip range: 4 - 6 mm  
Hardness: SH 70  
Insert: 33 x 0,47 mm steel  
Flame retardant EPDM DIN5510-2

**33.1154**

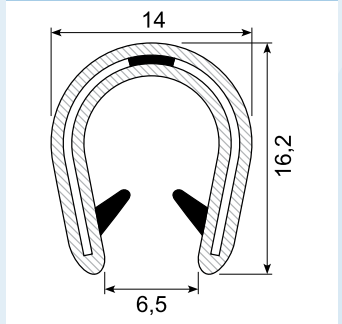

Edge trim: PVC black  
Grip range: 6 - 8 mm mm  
Hardness: SH 75 / 75  
White lips

**33.428 / 33.428G**

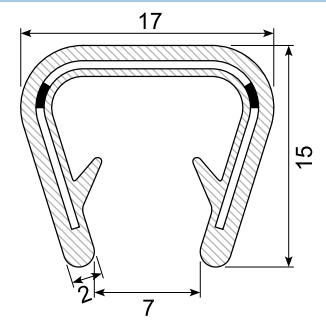

Edge trim: PVC black + bi  
Grip range: 10 - 12 mm  
Hardness: SH 78  
Insert: 36 x 0,5 mm steel  
33.428G (grey)

**33.1155**

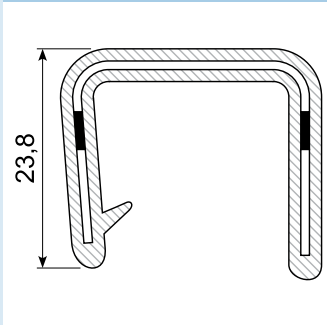

Edge trim: PVC black  
Grip range: 15 - 16 mm  
Hardness: SH 85  
Insert: Steel

**33.1156**

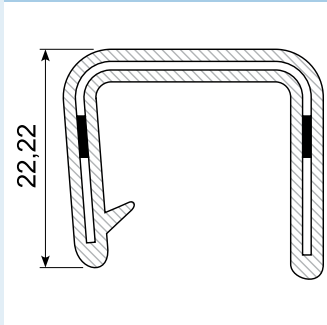

Edge trim: PVC black  
Grip range: 18 - 19 mm  
Hardness: SH 85  
Insert: Steel

**33.354**

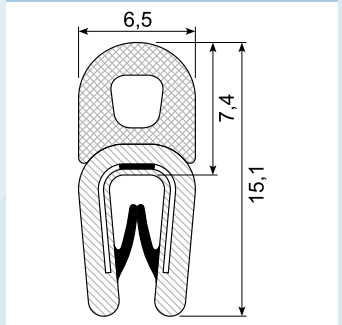

Edge trim: PVC+bi / sponge rubber  
Grip range: 1 - 2 mm  
Hardness: SH 78 / 57 / density 0,55  
Insert: 16 x 0,3 mm steel

**33.368 \* \*\***

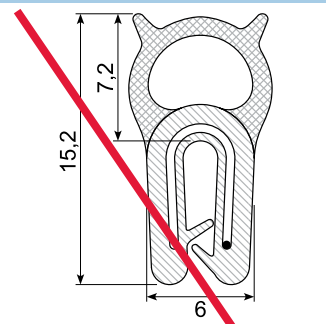

Edge trim: EPDM co-ex  
Grip range: 0,5 - 1,5 mm  
Hardness: SH 60 / density 0,55  
Insert: wire  
Min. order: 6.000 mtr.

**33.468F**

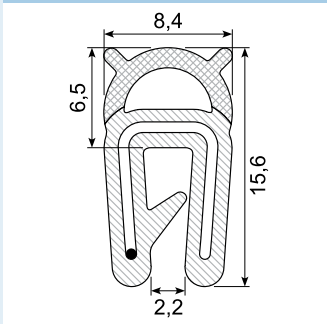

Edge trim: EPDM co-ex  
Grip range: 1 - 2 mm  
Hardness: SH 60 / density 0,8  
Insert: 22 x 0,75 mm wire  
Flame retardant EN 45545

**33.468X**

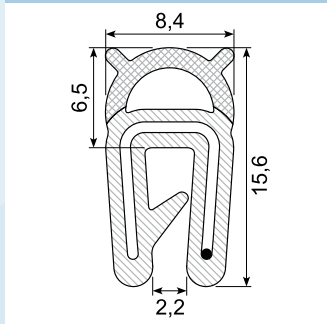

Edge trim: EPDM co-ex  
Grip range: 1 - 2 mm  
Hardness: SH 60 / density 0,55  
Insert: 22 x 0,75 mm wire

**33.468B \***

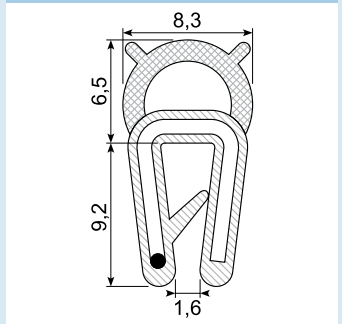

Edge trim: EPDM co-ex  
Grip range: 1 - 2 mm  
Hardness: SH 70 / density 0,55  
Insert: 22 mm wire  
Min. order: 3.000 mtr.

\* Skaffevare / Special order item \*\* Opdateret siden tryk / Updated since print

**33.358C \***

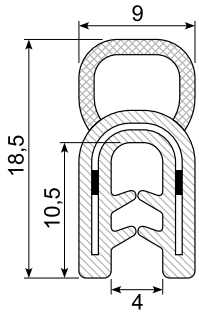

Edge trim: EPDM co-ex  
Grip range: 0,8 - 2,5 mm  
Hardness: SH 65  
Insert: 25 x 0,5 mm steel  
Min. order: 3.000 m

**33.021**

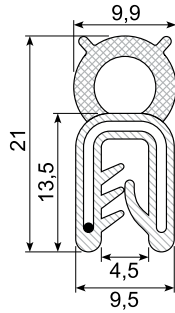

Edge trim: EPDM co-ex  
Grip range: 0,8 - 2 mm  
Hardness: SH 70 / density 0,55  
Insert: 25 mm wire

**33.358X**

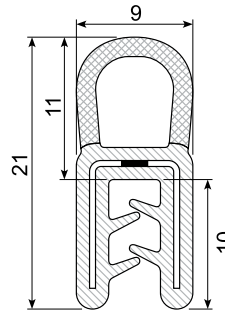

Edge trim: EPDM co-ex  
Grip range: 1 - 3,5 mm (1 - 3 mm)  
Hardness: SH 70 / density 0,55  
Insert: 26 x 0,5 mm  
Unbroken

**33.358B**

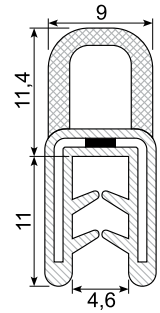

Edge trim: EPDM co-ex  
Grip range: 1 - 3 mm  
Hardness: SH 70 / density 0,55  
Insert: 27 mm

**33.370NBR**

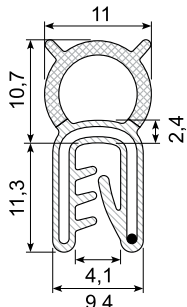

Edge trim: NBR co-ex  
Grip range: 1 - 3 mm  
Hardness: SH 70 / density 0,55  
Insert: Wire  
**Oil resistant**

**33.371A \* \*\***

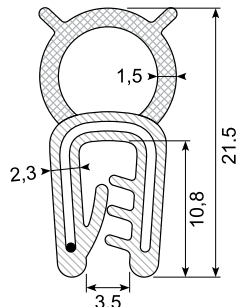

Edge trim: EPDM co-ex  
Grip range: 1 - 3 mm  
Hardness: SH 60 / density 0,55  
Insert: 26 x 0,76 mm wire  
Min. order: 7.000 m

**33.371E EMV - EMC - EMI \***

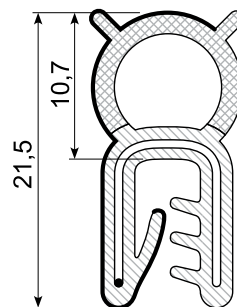

Edge trim: EPDM co-ex  
Grip range: 1 - 3 mm  
Hardness: SH 70 / density 0,55  
Insert: Wire  
**Electromagnetic compatibility. On demand**

**33.371F**

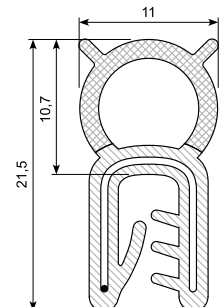

Edge trim: EPDM co-ex  
Grip range: 1 - 3 mm  
Hardness: SH 65 / density 0,6  
Insert: 26 x 0,75 mm wire  
**Flame retardant NFF16-101**  
Min. 4.000 m

**33.469X**

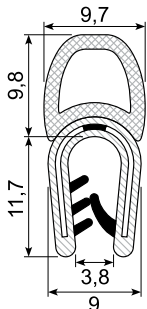

Edge trim: PVC+bi / sponge rubber  
Grip range: 1,5 - 3,5 mm  
Hardness: SH 75 / 63  
density 0,6 - 0,85  
Insert: 26 x 0,47 mm steel

**33.371FX**

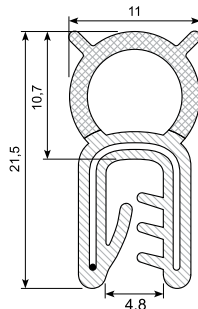

Edge trim: EPDM co-ex  
Grip range: 1 - 3 mm  
Hardness: SH 60 / density 0,8  
Insert: 26 x 0,75 mm wire  
**Flame retardant EN 45545**

**33.371X**

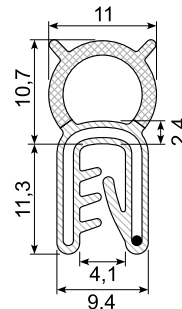

Edge trim: EPDM co-ex  
Grip range: 1 - 3,5 mm (1 - 3 mm)  
Hardness: SH 70 / density 0,55  
Insert: 27 mm wire

**33.369**

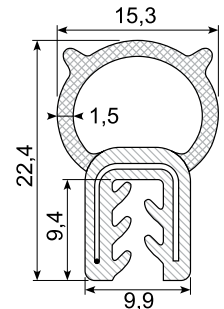

Edge trim: EPDM co-ex  
Grip range: 2 - 4 mm  
Hardness: SH 65 / density 0,6  
Insert: Wire

**33.481**

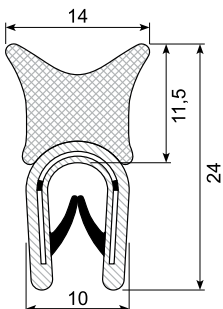

Edge trim: PVC + bi / spongerubber  
Grip range: 1 - 4 mm  
Hardness: SH 57 / 78 / density 0,55  
Insert: Steel

**33.353NBR**

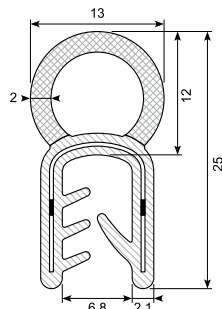

Edge trim: Co-ex  
Grip range: 3 - 4 mm  
Hardness: SH 70 / density 0,55  
Insert: 31 x 0,5 mm  
Min. order: 3.000 m

**33.353S \***

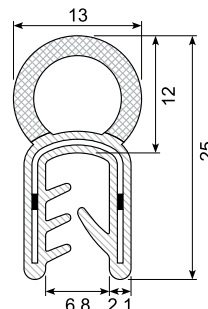

Edge trim: EPDM co-ex  
Grip range: 3 - 4 mm  
Hardness: SH 65 / density 0,6  
Insert: 31 x 0,5 mm steel  
Min. order: 6.000 m

**33.353**

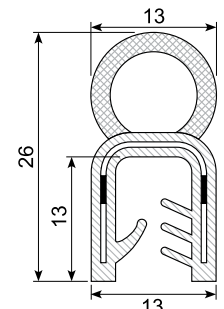

Edge trim: EPDM co-ex  
Grip range: 3 - 5 mm  
Hardness: SH 65 / density 0,6  
Insert: 32 mm steel

**33.352 \***

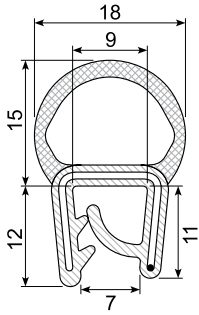

Edge trim: EPDM co-ex  
Grip range: 5 - 6 mm  
Hardness: SH 78 / density 0,6  
Insert: 31 x 0,5 mm  
Min. order: 2.000 m

**33.362FX**

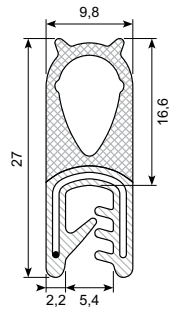

Edge trim: EPDM co-ex  
Grip range: 1 - 3,5 mm  
Hardness: SH 60 / density 0,8  
Insert: 26 x 0,75 mm wire  
**Flame retardent EN 45545**

**33.357X**

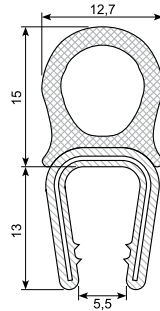

Edge trim: PVC / sponge rubber  
Grip range: 5 - 7 mm  
Hardness: SH 78 / density 0,6  
Insert: 31 x 0,5 mm

**33.359X**

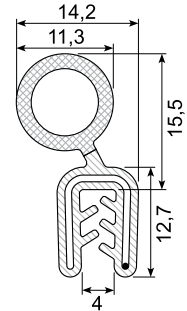

Edge trim: EPDM co-ex  
Grip range: 1,5 - 4 mm  
Hardness: SH 70 / density 0,6 - 0,85  
Insert: 25 wire

~~**33.362B \* \*\***~~

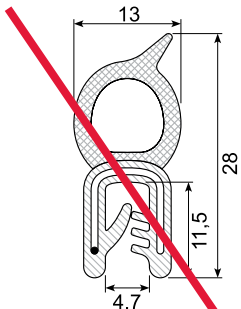

~~Edge trim: EPDM co-ex  
Grip range: 1 - 3,5 mm  
Hardness: SH 70 / density 0,55  
Insert: 26 x 0,76 mm wire  
Min. order: 5.500 m~~

~~**33.362A \* \*\***~~

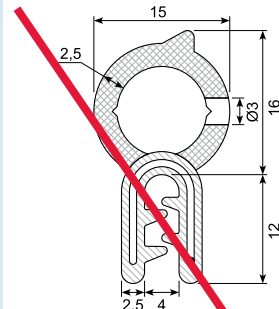

~~Edge trim: EPDM co-ex  
Grip range: 1 - 2,5 mm  
Hardness: SH 70 / density 0,55  
Insert: 26 x 0,76 mm wire  
Min. order: 5.500 m~~

**33.353X**

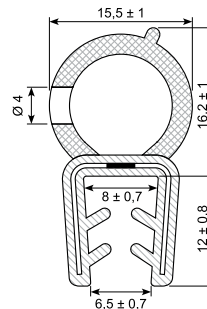

Edge trim: EPDM co-ex  
Grip range: 4 - 6 mm  
Hardness: SH 65 / density 0,6  
Insert: 33 mm steel

**33.376**

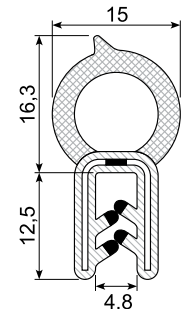

Edge trim: EPDM co-ex  
Grip range: 1 - 3,5 mm  
Hardness: SH 70 / density 0,75  
Insert: 27 mm steel

~~**33.361 \* \*\***~~

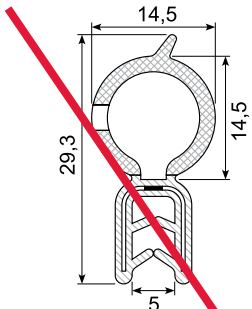

~~Edge trim: EPDM co-ex  
Grip range: 1 - 4 mm  
Hardness: SH 70 / density 0,55  
Insert: 26 x 0,5 mm steel  
Min. order: 5.500 m~~

~~**33.361B \* \*\***~~

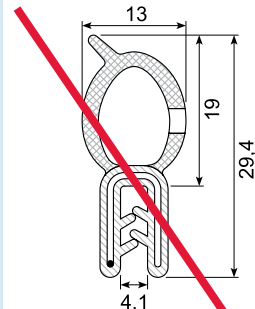

~~Edge trim: EPDM co-ex  
Grip range: 1 - 2,5 mm  
Hardness: SH 65 / density 0,55  
Insert: 26 x 0,76 mm wire  
Min. order: 5.500 m~~

**33.360**

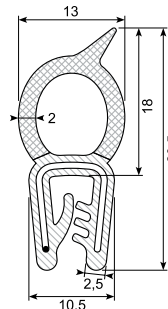

Edge trim: EPDM co-ex  
Grip range: 1 - 2,5 mm  
Hardness: SH 60 / density 0,6  
Insert: 27 x 0,75 mm wire

**33.360NBR \***

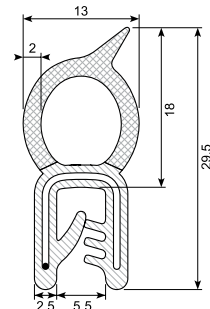

Edge trim: NBR co-ex  
Grip range: 1 - 3 mm  
Hardness: SH 70 / density 0,55  
Insert: 27 x 0,75 wide  
**Oil resistant**  
Min. order: 4.000 m

**33.377**

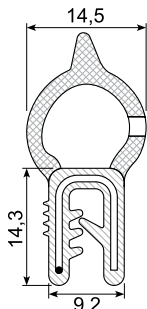

Edge trim: EPDM co-ex  
Grip range: 1 - 3,5 mm  
Hardness: SH 70 / density 0,75  
Insert: 27 mm wire

**33.360F**

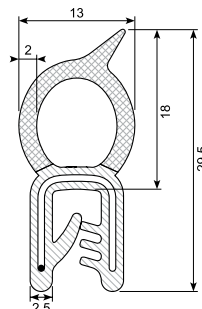

Edge trim: EPDM co-ex  
Grip range: 2 - 4 mm  
Hardness: SH 65 / density 0,6  
Insert: 27 x 0,76 mm wire  
**Flame retardent NFF16-101**  
Min. 3.000 m

**33.360X**

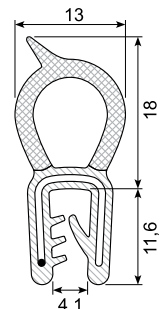

Edge trim: EPDM co-ex  
Grip range: 1 - 3 mm  
Hardness: SH 70 / density 0,6  
Insert: 27 x 0,75 mm wire

**33.365X**

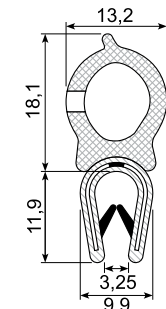

Edge trim: PVC+bi sponge rubber  
Grip range: 1 - 4 mm  
Hardness: SH 75 / 63 / density 0,6 - 0,85  
Insert: 26 x 0,47 mm steel



**33.362F \***

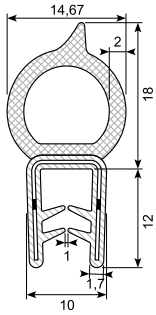

Edge trim: EPDM co-ex  
 Grip range: 2 - 4 mm  
 Hardness: SH 65 / density 0,6  
 Insert: 29 x 0,5 mm steel  
 Min. order: 1.000 m  
 Flame retardant BS6853 and DIN5510

**33.374**

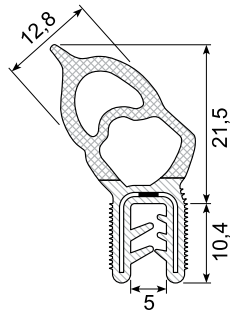

Edge trim: EPDM co-ex  
 Grip range: 1,5 - 4 mm  
 Hardness: SH 70 / density 0,55  
 Insert: 27 x 0,47 mm steel

**33.362D \***

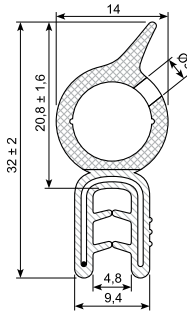

Edge trim: EPDM co-ex  
 Grip range: 2 - 4 mm  
 Hardness: SH 65 / density 0,6  
 Insert: 27 x 0,75 mm wire  
 Min. order: 4.029 m

**33.360R**

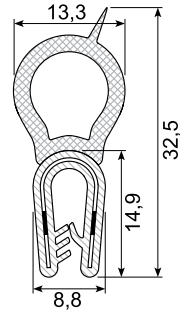

Edge trim: PVC sponge rubber  
 Grip range: 1 - 2,5 mm  
 Hardness: SH 77 / density 0,65 - 0,75  
 Insert: 26 x 0,5 mm stainless 304 steel

**33.362E \***

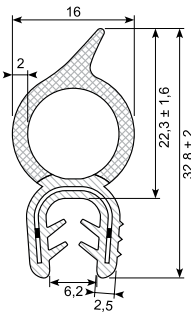

Edge trim: EPDM co-ex  
 Grip range: 3 - 5 mm  
 Hardness: SH 65 / density 0,6  
 Insert: 26 x 0,5 mm steel  
 Min. order: 4.050 m

**33.362**

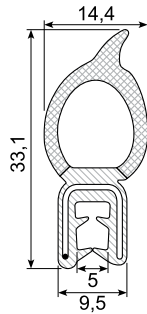

Edge trim: EPDM co-ex  
 Grip range: 1 - 3,5 mm  
 Hardness: SH 70 / density 0,6  
 Insert: 26 x 0,76 mm wire

**33.362C \***

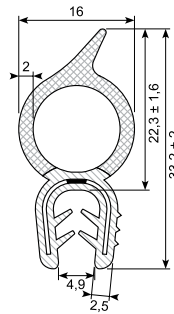

Edge trim: EPDM co-ex  
 Grip range: 1,5 - 3 mm  
 Hardness: SH 65 / density 0,6  
 Insert: 26 x 0,5 mm steel  
 Min. order: 4.050 m

**33.025**

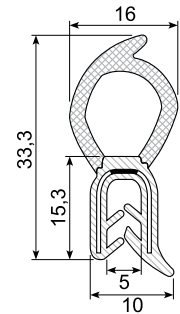

Edge trim: EPDM co-ex  
 Grip range: 1,5 - 3,5 mm  
 Hardness: SH 70 / density 0,55  
 Insert: 27 x 0,47 mm steel

**33.367**

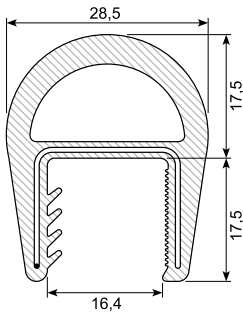

Edge trim: EPDM solid balloon  
 Grip range: 16 mm  
 Hardness: SH 60  
 Insert: 52 x 0,76 mm wire

**33.380**

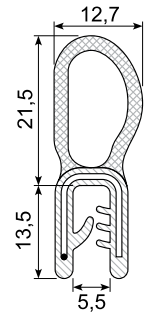

Edge trim: EPDM co-ex  
 Grip range: 2 - 4 mm  
 Hardness: SH 70 / density 0,55  
 Insert: 29 mm wire

**33.379**

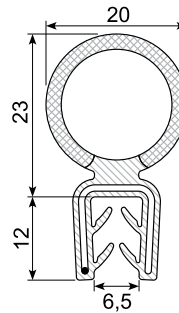

Edge trim: EPDM co-ex  
 Grip range: 2,5 - 5 mm  
 Hardness: SH 70 / density 0,55  
 Insert: 33 mm wire

**33.378**

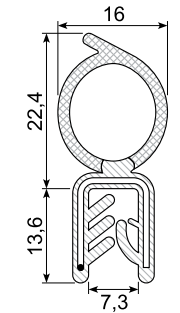

Edge trim: EPDM co-ex  
 Grip range: 1,5 - 5 mm  
 Hardness: SH 70 / density 0,55  
 Insert: 33 mm wire

**33.375**

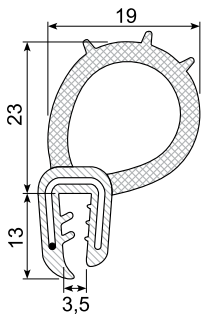

Edge trim: EPDM co-ex  
 Grip range: 4 - 5 mm  
 Hardness: SH70 / density 0,6 - 0,85  
 Insert: 27 mm wire

**33.463**

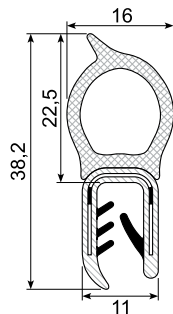

Edge trim: PVC+bi / sponge rubber  
 Grip range: 4 - 6 mm  
 Hardness: SH78/57 density 0,55  
 Insert: 31 x 0,5 mm steel

**33.355B**

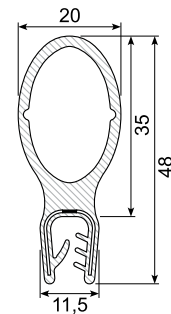

Edge trim: EPDM solid balloon  
 Grip range: 3 - 5 mm  
 Hardness: SH 60  
 Insert: 31 x 0,5 mm steel unbroken

**33.408X**

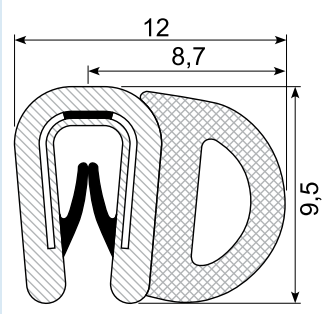

Edge trim: PVC+bi / sponge rubber  
 Grip range: 1 - 2 mm  
 Hardness: SH 78 / 57 density 0,55  
 Insert: 16 x 0,3 mm steel  
 \* Skaffevare / Special order item

**33.404 \* \*\***

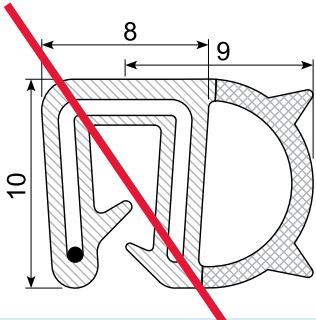

Edge trim: EPDM co-ex  
Grip range: 1 - 2,5 mm  
Hardness: SH 60 / density 0,55  
Insert: 20 x 0,76 mm wire  
Min. order: 5.500 m

**33.407X**

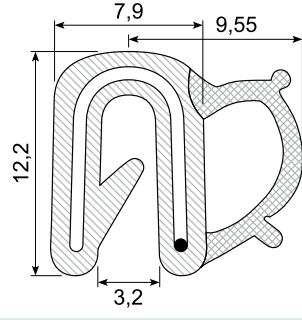

Edge trim: EPDM co-ex  
Grip range: 0,8 - 2,5 mm  
Hardness: SH 60 / density 0,55  
Insert: 22 x 0,75 mm wire

**33.403 \* \*\***

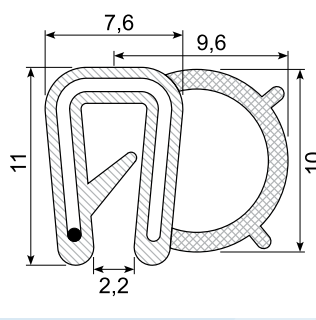

Edge trim: EPDM co-ex  
Grip range: 1 - 2 mm  
Hardness: SH 70 / density 0,55  
Insert: 20 x 0,76 mm wire  
Min. order: 8.000 m

**33.403F**

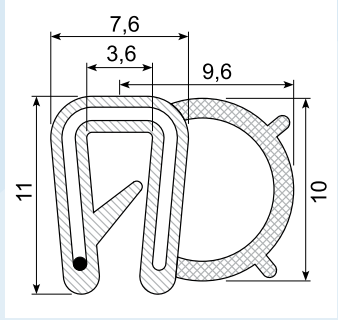

Edge trim: EPDM co-ex  
Grip range: 1 - 2 mm  
Hardness: SH 60 / density 0,8  
Insert: 22 x 0,75 mm wire  
**Flame retardent EN 45545**

**33.405 \* \*\***

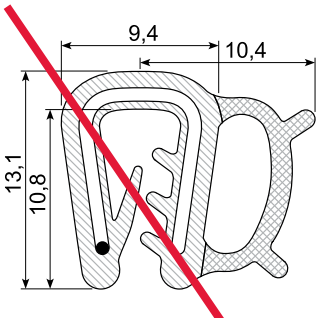

Edge trim: EPDM co-ex  
Grip range: 1 - 2 mm  
Hardness: SH 70 / density 0,55  
Insert: Wire  
Min. order: 5.500 m

**33.9779 \*\***

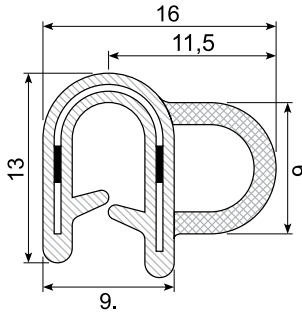

Edge trim: EPDM co-ex  
Grip range: 1,5 - 3 mm (1 - 3 mm)  
Hardness: SH 70 / density 0,65  
Insert: 25 x 0,5 mm steel

**33.395A**

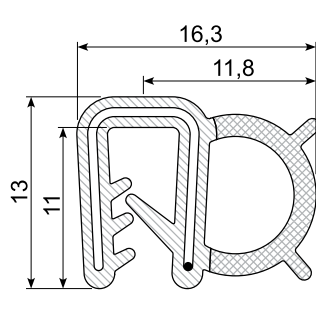

Edge trim: EPDM co-ex  
Grip range: 2 mm  
Hardness: SH 60 / density 0,6  
Insert: 26 x 0,75 mm wire

**33.395F**

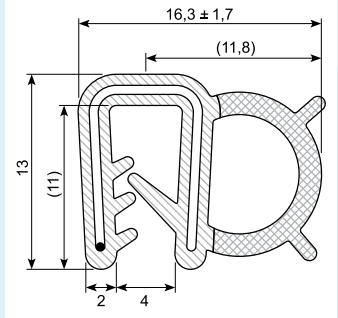

Edge trim: EPDM co-ex  
Grip range: 1 - 3 mm  
Hardness: SH 60 / density 0,8  
Insert: 26 x 0,75 mm wire  
**Flame retardent EN 45545**

**33.395X**

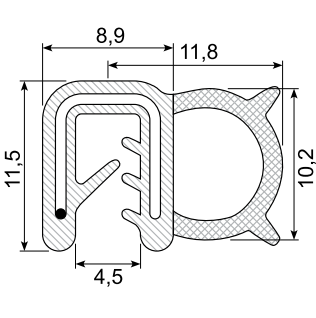

Edge trim: EPDM co-ex  
Grip range: 1 - 3 mm  
Hardness: SH 70 / density 0,55  
Insert: Wire

**33.398**

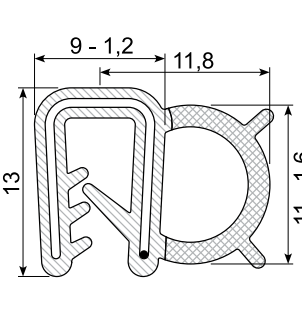

Edge trim: NBR co-ex  
Grip range: 2 mm  
Hardness: SH 60 / density 0,55  
Insert: 27 x 0,76 mm wire  
**Oil resistant**

**33.381**

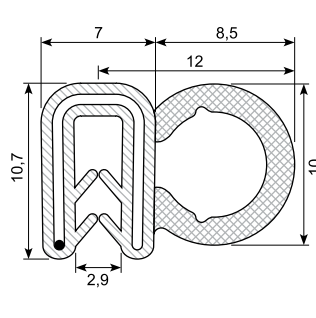

Edge trim: EPDM co-ex  
Grip range: 1 - 2,5 mm  
Hardness: SH 70 density 0,55  
Insert: Wire

**33.444A**

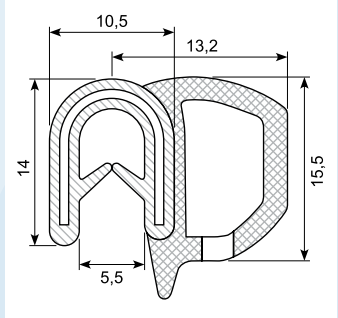

Edge trim: EPDM co-ex  
Grip range: 1,5 - 4 mm  
Hardness: SH 70 / density 0,55  
Insert: Wire  
Min. order: 1.000 m

**33.372X**

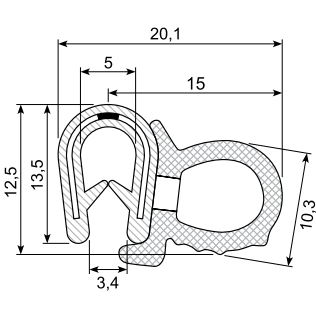

Edge trim: PVC + sponge rubber  
Grip range: 1 - 3,5 mm  
Hardness: SH 75 / 75 / density 0,6 - 0,85  
Insert: 22 x 0,47 mm steel

**33.506 \* \*\***

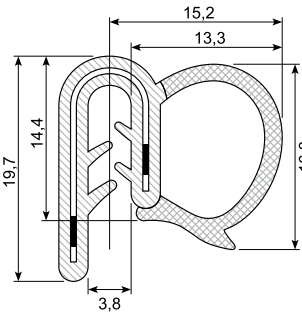

Edge trim: EPDM co-ex  
Grip range: 1 - 2,5 mm  
Hardness: SH 70 / density 0,6  
Insert: 30 x 0,47 mm steel  
On demand min. 4.000 m

**33.480**

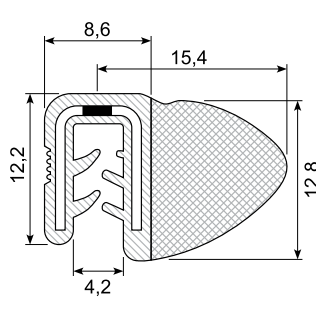

Edge trim: EPDM co-ex  
Grip range: 1 - 3,5 mm  
Hardness: SH 70 / density 0,55  
Insert: Steel

**33.396**

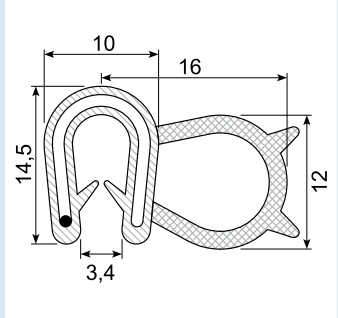

Edge trim: EPDM co-ex  
Grip range: 1 - 3 mm  
Hardness: SH 70 density 0,6 - 0,85  
Insert: 27 mm wire

33.444X

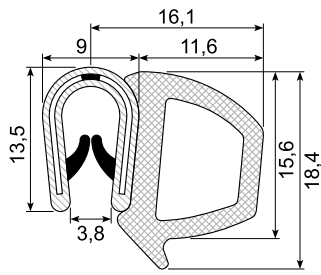

Edge trim: PVC + sponge rubber  
Grip range: 1 - 3,5 mm  
Hardness: SH75/75/density 0,6-0,86  
Insert: 26 x 0,47 mm steel  
Red lips

33.319

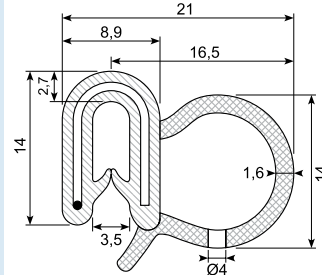

Edge trim: EPDM co-ex  
Grip range: 1 - 3 mm  
Hardness: SH 70 / density 0,6 0,85  
Insert: Wire

33.319F \*

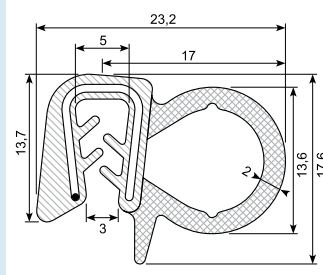

Edge trim: EPDM co-ex  
Grip range: 1 - 2 mm  
Hardness: SH 70 / density 0,6  
Insert: 26 x 0,75 mm wire  
Flame retardant NFF16-101  
Min. order: 3.000 m

33.323

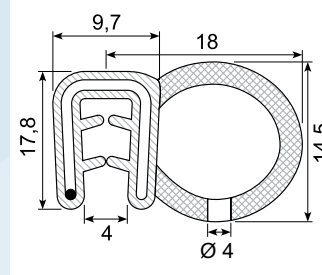

Edge trim: EPDM co-ex  
Grip range: 1,5 - 3,5 mm  
Hardness: SH 70  
density 0,6 - 0,85  
Insert: 27 mm

33.324CR

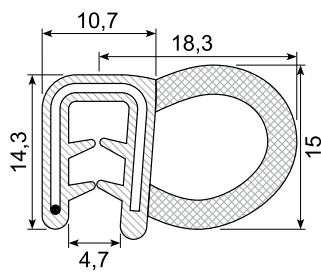

Edge trim: CR co-ex  
Grip range: 1 - 3,5 mm  
Hardness: SH70 / density 0,6 - 0,85  
Insert: 29 mm wire  
Conditional oil resistant

33.338 \* \*\*

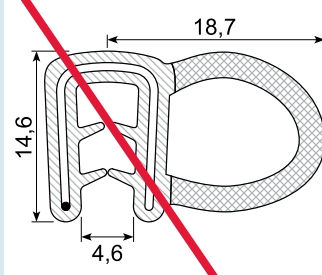

Edge trim: EPDM co-ex  
Grip range: 1,5 - 3 mm  
Hardness: SH 60 / density 0,55  
Insert: 29 x 0,76 mm wire  
Min. order: 5.000 m

33.338F

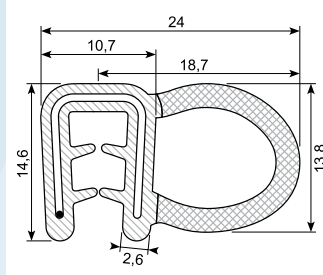

Edge trim: EPDM co-ex  
Grip range: 1,5 - 3 mm  
Hardness: SH 65 / density 0,60  
Insert: 30 x 0,75 mm wire  
Flame retardant EN45545

33.336 \* \*\*

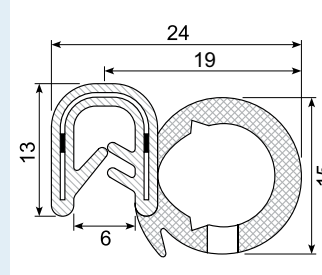

Edge trim: EPDM co-ex  
Grip range: 1,5 - 3,5 mm  
Hardness: SH 70 / density 0,55  
Insert: 26 x 0,5 mm steel  
Min. order: 6.700 m

33.450NBR

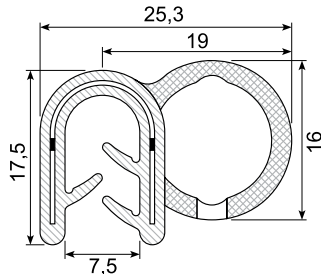

Edge trim: NBR co-ex  
Grip range: 4 - 6 mm (3 - 6 mm)  
Hardness: SH 70 / density 0,55  
Insert: 34 x 0,5 mm steel  
Oil resistant

33.457

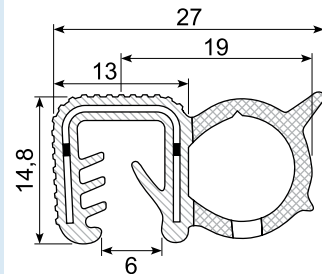

Edge trim: EPDM co-ex  
Grip range: 5 - 6 mm  
Hardness: SH 60 / density 0,6  
Insert: 32 x 0,6 mm steel unbroken

33.457ST

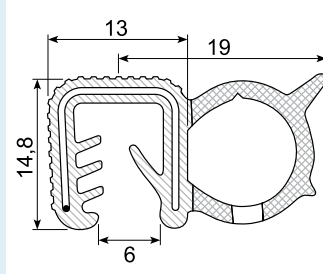

Edge trim: EPDM co-ex  
Grip range: 5 - 6 mm  
Hardness: SH 60 / density 0,55  
Insert: 31 x 0,76 mm wire

33.449

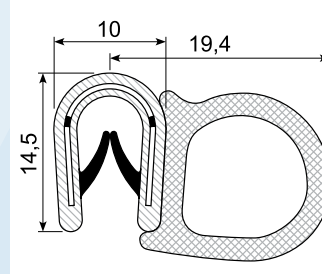

Edge trim: PVC+bi / sponge rubber  
Grip range: 1 - 4 mm  
Hardness: SH78/57 / density 0,55  
Insert: 26 x 0,5 mm steel

33.321

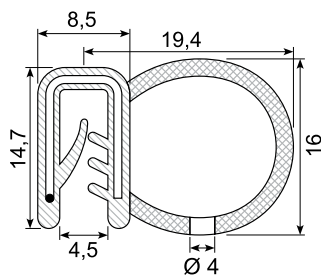

Edge trim: EPDM co-ex  
Grip range: 1 - 3,5 mm  
Hardness: SH 70 / density 0,6 - 0,85  
Insert: 27 mm wire

33.452R

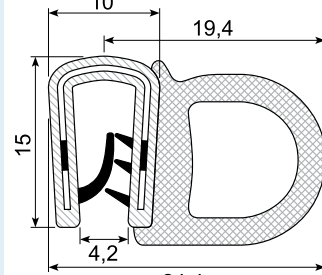

Edge trim: PVC+bi / sponge rubber  
Grip range: 2 - 4 mm  
Hardness: SH 78 / 65  
density 0,65 - 0,75  
Insert: 29 x 0,48 mm stainless steel

33.457S-6

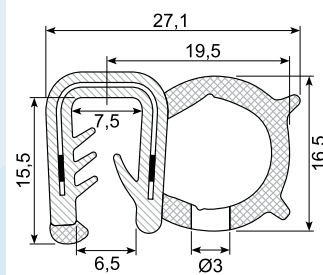

Edge trim: EPDM co-ex  
Grip range: 3 - 6 mm  
Hardness: SH 70 / density 0,6  
Insert: 32 x 0,47 steel

33.024

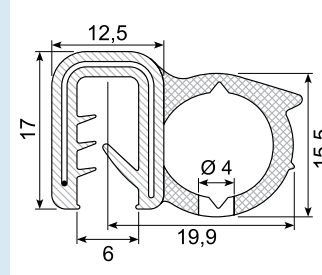

Edge trim: EPDM co-ex  
Grip range: 2 - 4 mm (2 - 5 mm)  
Hardness: SH 70 / density 0,55  
Insert: 33 mm wire

**33.454X**

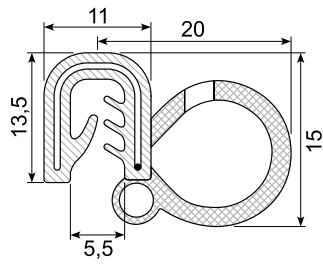

Edge trim: EPDM co-ex  
Grip range: 2 mm  
Hardness: SH 70 / density 0,55  
Insert: 27 x 0,76 mm wire

**33.335**

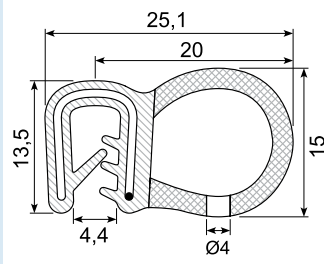

Edge trim: EPDM co-ex  
Grip range: 1,5 - 3,5 mm  
Hardness: SH70/density 0,55-0,85  
Insert: 27 mm wire

**33.457S-4 \***

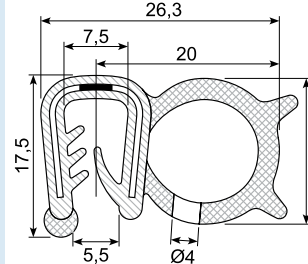

Edge trim: EPDM co-ex  
Grip range: 2 - 4 mm  
Hardness: SH 70 / density 0,6  
Insert: Steel  
Min. order: 3.000 m

**33.333 \***

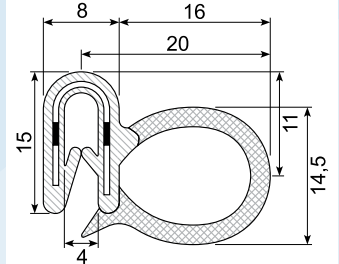

Edge trim: EPDM co-ex  
Grip range: 1 - 3 mm  
Hardness: SH 65 / density 0,6  
Insert: 29 x 0,5 mm steel  
Min. order: 4.000 m

**33.451E**

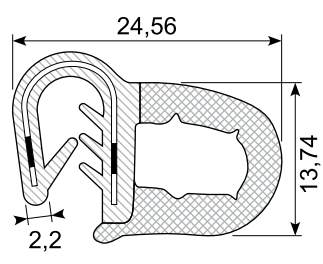

Edge trim: EPDM co-ex

**33.020**

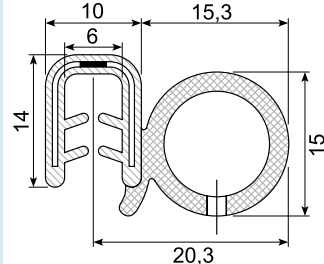

Edge trim: EPDM co-ex  
Grip range: 1,5 - 3 mm  
Hardness: SH 70 / density 0,55  
Insert: 27 x 0,47 mm steel

**33.332X \***

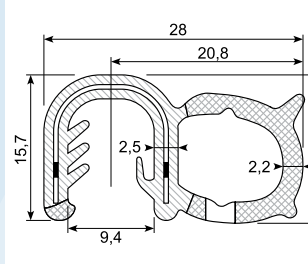

Edge trim: EPDM co-ex  
Grip range: 5 - 6 mm  
Hardness: SH 70 / density 0,6  
Insert: 33 x 0,5 steel  
Min. order: 5.000 m

**33.470**

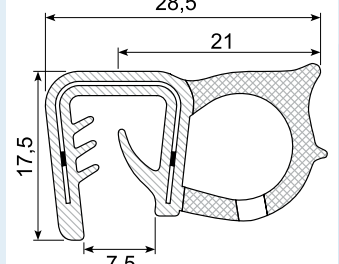

Edge trim: EPDM co-ex  
Grip range: 5 - 8 mm  
Hardness: SH 70 / density 0,6  
Insert: 36 x 0,5 mm steel

**33.339X**

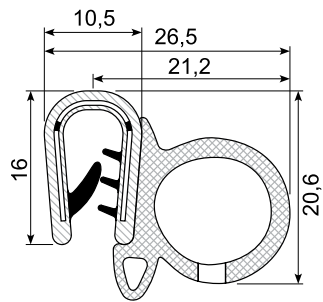

Edge trim: PVC+bi / sponge rubber  
Grip range: 2,5 - 4 mm  
Hardness: SH 78 / 65  
Insert: Steel

**33.456**

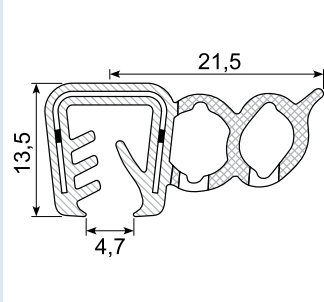

Edge trim: EPDM co-ex  
Grip range: 5 - 6 mm  
Hardness: SH 70 / density 0,6  
Insert: 30 x 0,6 mm steel

**33.12116 \***

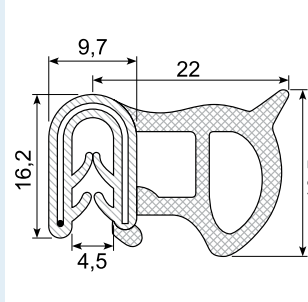

Edge trim: EPDM co-ex  
Grip range: 1 - 4 mm  
Hardness: SH 70 / density 0,6 - 0,85  
Insert: 29 mm wire  
Min. order: 3.000 m

**33.328 \***

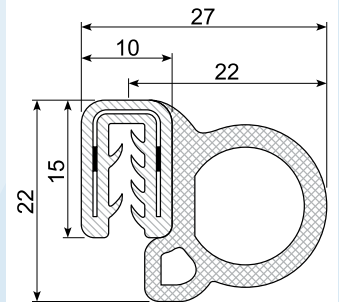

Edge trim: EPDM co-ex  
Grip range: 1,5 - 2,5 mm  
Hardness: SH 65 / density 0,6  
Insert: 29 x 0,5 mm steel  
Min. order: 4.000 m

**33.022**

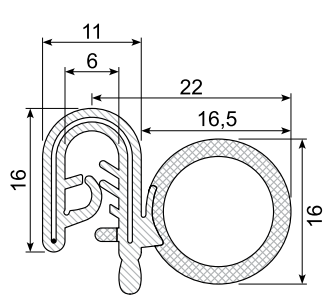

Edge trim: EPDM co-ex  
Grip range: 1,5 - 3 mm (1,5 - 4 mm)  
Hardness: SH 70 / density 0,6  
Insert: 33 mm wire

**33.340**

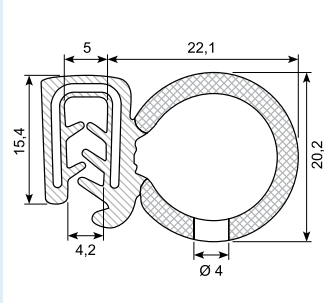

Edge trim: EPDM co-ex  
Grip range: 2 - 4 mm  
Hardness: SH 70  
Insert: 29 x 0,74 mm steel

**33.332B**

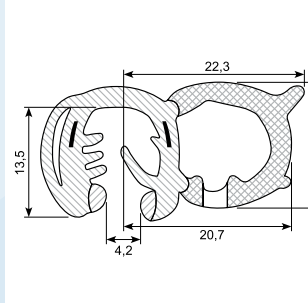

Edge trim: EPDM co-ex  
Grip range: 3 - 6 mm  
Hardness: SH 70 / density 0,55  
Insert: 32 mm Steel

**33.453X**

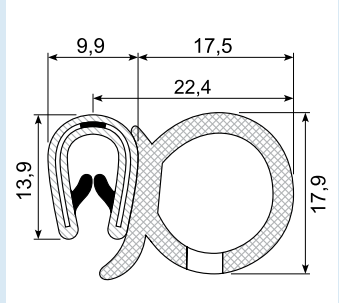

Edge trim: PVC + sponge rubber  
Grip range: 1 - 3,5 mm  
Hardness: SH75/75 density 0,6-0,85  
Insert: 26 x 0,47 mm steel

33.320 \*

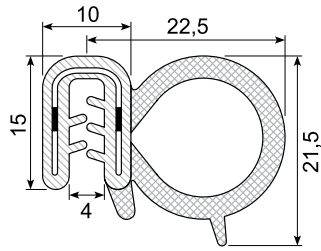

Edge trim: EPDM co-ex  
Grip range: 1 - 2,5 mm  
Hardness: SH 65 / density 0,6  
Insert: 29 x 0,5 mm steel  
Min. order: 4.000 m

33.019

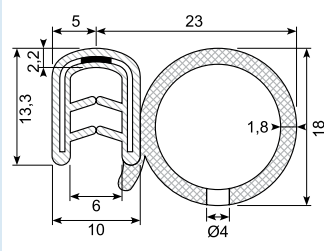

Edge trim: EPDM co-ex  
Grip range: 1 - 4 mm  
Hardness: SH 70 / density 0,6 - 0,85  
Insert: Steel

33.447

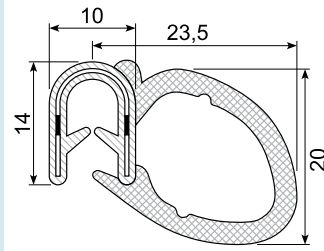

Edge trim: EPDM co-ex  
Grip range: 2,5 - 5 mm  
Hardness: SH 70 / density 0,6  
Insert: Steel

33.455

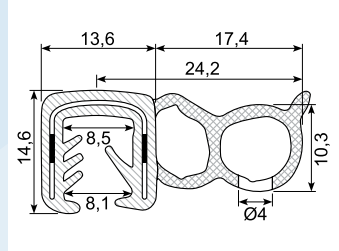

Edge trim: EPDM co-ex  
Grip range: 4 - 6 mm  
Hardness: SH 70 / density 0,6  
Insert: Steel unbroken

33.452X

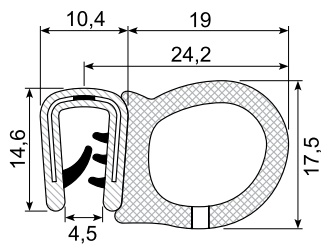

Edge trim: PVC+bi / sponge rubber  
Grip range: 2 - 4 mm  
Hardness: SH 78 / 65  
density 0,65 - 0,75  
Insert: 29 x 0,48 mm

33.326

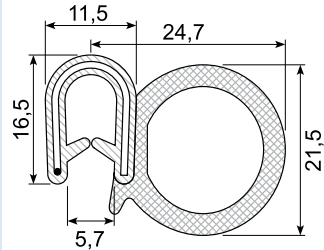

Edge trim: EPDM co-ex  
Grip range: 1,5 - 4 mm  
Hardness: SH70/density 0,55 - 0,85  
Insert: 33 mm wire

33.464

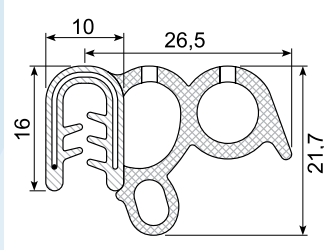

Edge trim: EPDM co-ex  
Grip range: 1,5 - 3,5 mm  
Hardness: SH 70 / density 0,6  
Insert: 31 x 0,75 mm wire

33.331

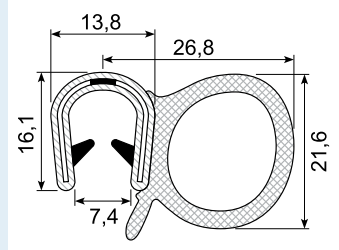

Edge trim: PVC + sponge rubber  
Grip range: 6 - 8 mm  
Hardness: SH75/75 density 0,6-0,85  
Insert: 30 x 0,47 mm steel  
White lips

33.456F

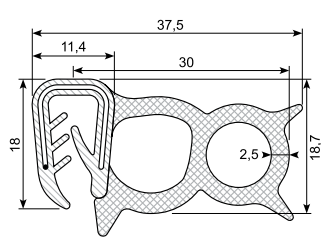

Edge trim: EPDM co-ex  
Grip range: 2 - 4 mm  
Hardness: SH 65 / density 0,6  
Insert: 31 x 0,75 mm wire  
Flame retardent NFF16-101  
Min. order: 3.000 m

33.478

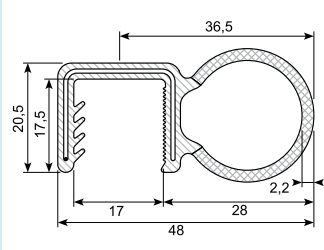

Edge trim: EPDM co-ex  
Grip range: 16 mm  
Hardness: SH 60 / density 0,6  
Insert: 52 x 0,76 mm wire

33.458X

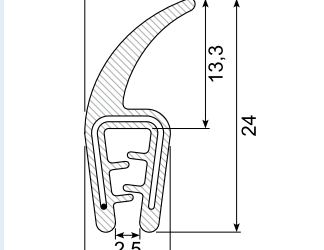

Edge trim: EPDM solid lip  
Grip range: 1 - 2,5 mm  
Hardness: SH 60  
Insert: 26 x 0,76 mm wire

33.458A

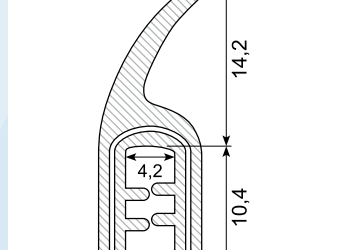

Edge trim: EPDM co-ex  
Grip range: 1 - 3 mm  
Hardness: SH 70  
Insert: Wire

33.465C

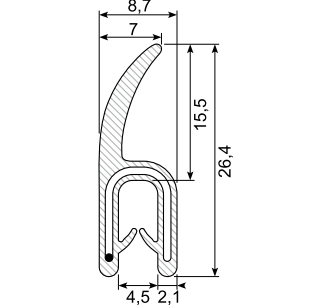

Edge trim: EPDM solid lip  
Grip range: 2 - 4 mm  
Hardness: SH 70  
Insert: 27 x 0,76 mm wire

33.465X

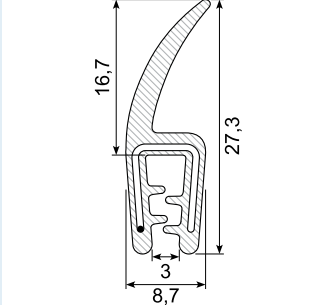

Edge trim: EPDM solid lip  
Grip range: 1 - 3 mm  
Hardness: SH 60  
Insert: 26 x 0,76 mm wire

33.479

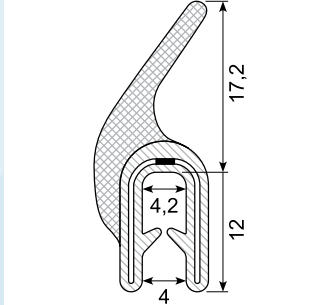

Edge trim: EPDM co-ex  
Grip range: 2 - 4 mm  
Hardness: SH 70 / density 0,6  
Insert: Steel

33.465B \*

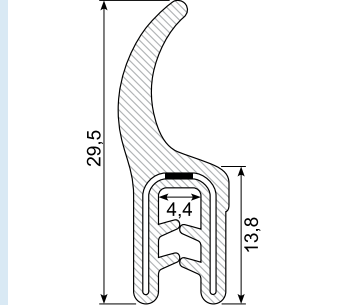

Edge trim: EPDM solid lip  
Grip range: 1 - 3 mm  
Hardness: SH 70  
Insert: 27 x 0,5 mm steel unbroken  
Min. ordre: 3.000 m  
\* Skaffevare / Special order item

**33.459P**

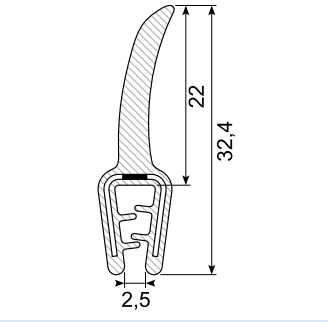

Edge trim: PVC solid lip  
Grip range: 1 - 2,5 mm  
Hardness: SH 57  
Insert: 24 x 0,5 mm steel unbroken

**33.459X**

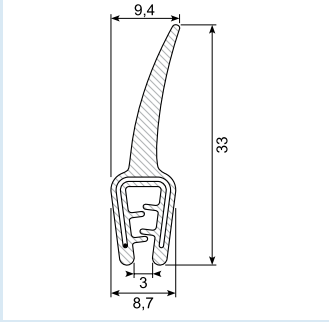

Edge trim: EPDM solid lip  
Grip range: 1 - 2,5 mm  
Hardness: SH 60  
Insert: 26 x 0,76 mm wire

**33.459B**

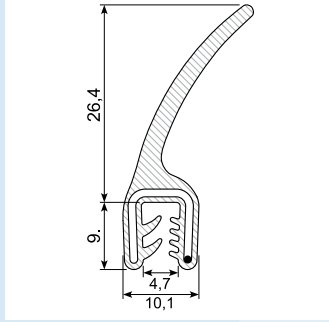

Edge trim: EPDM solid lip  
Grip range: 1,5 - 3 mm  
Hardness: SH 70  
Insert: Wire

**33.475**

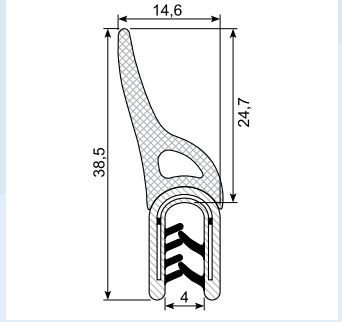

Edge trim: PVC + bi / sponge rubber  
Grip range: 2 - 4 mm  
Hardness: SH 78 / 57 / density 0,55  
Insert: Steel

**33.459C \***

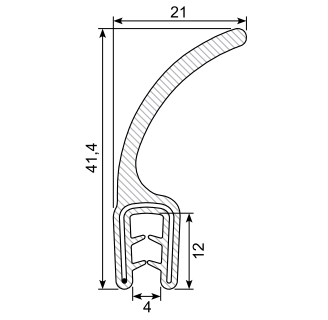

Edge trim: EPDM co-ex, solid lip  
Grip range: 2 - 4 mm  
Hardness: SH 60  
Insert: 29 x 0,76 wire  
Min. order: 6.000 m

**33.382**

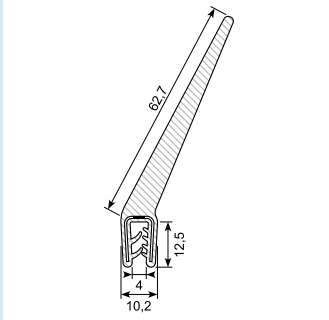

Edge trim: EPDM co-ex, solid lip  
Grip range: 1 - 3,5 mm  
Hardness: SH 70  
Insert: Steel

**33.482**

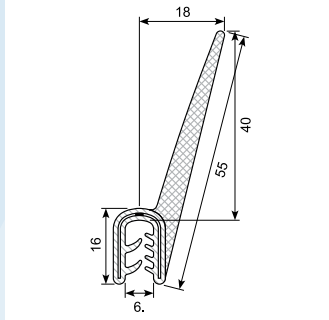

Edge trim: EPDM co-ex, solid lip  
Grip range: 2 - 4,5 mm  
Hardness: SH 70  
Insert: 30 x 0,47 mm steel

**33.483**

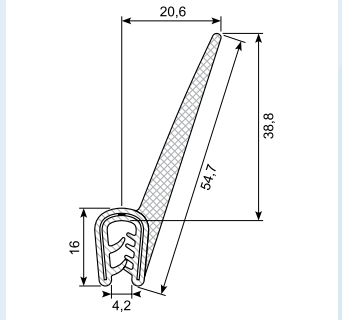

Edge trim: EPDM co-ex, solid lip  
Grip range: 1 - 2,5 mm  
Hardness: SH 70  
Insert: 30 x 0,47 mm steel

**33.460-2C**

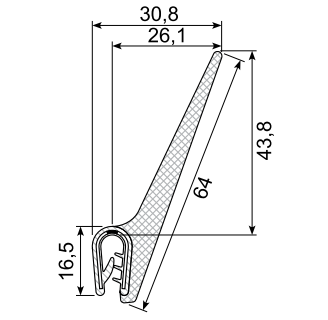

Edge trim: EPDM co-ex  
Grip range: 1 - 2,5 mm  
Hardness: SH 70 / density 0,6  
Insert: 31 x 0,5 mm steel unbroken

**33.460-2F \***

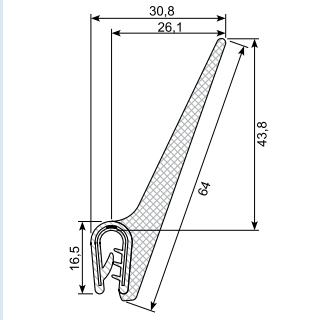

Edge trim: EPDM co-ex  
Grip range: 1 - 2,5 mm  
Hardness: SH 65 / density 0,6  
Insert: 31 x 0,5 mm steel  
**Flame retardant NFF16-101**  
Min. order: 3.000 m

**33.460-2**

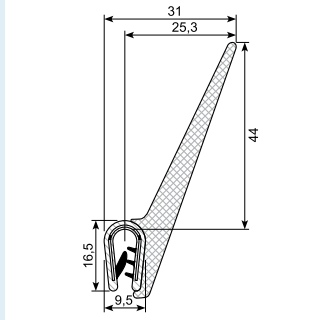

Edge trim: PVC+bi / sponge rubber  
Grip range: 1 - 2,5 mm  
Hardness: SH 78/57 / density 0,6  
Insert: 31 x 0,5 mm steel

**33.460-4**

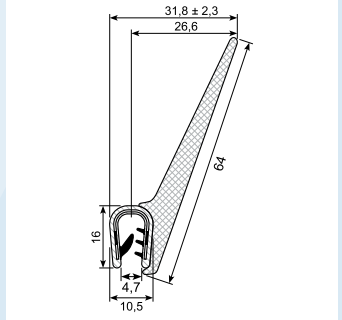

Edge trim: PVC+bi / sponge rubber  
Grip range: 2 - 4 mm  
Hardness: SH 78/57 / density 0,6  
Insert: 31 x 0,5 mm steel

**33.460-6**

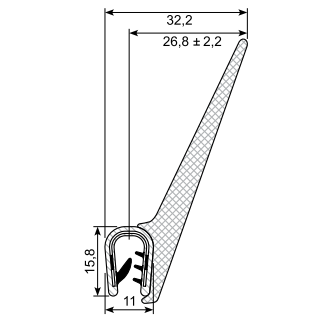

Edge trim: PVC+bi / sponge rubber  
Grip range: 4 - 6 mm 25 m  
Hardness: SH 78/57 / density 0,6  
Insert: 31 x 0,5 mm steel

**33.460-6A**

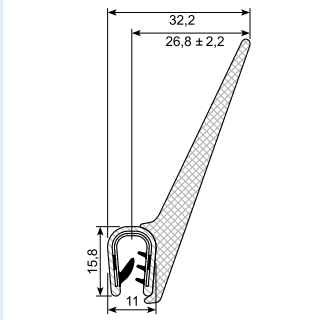

Edge trim: PVC+bi / sponge rubber  
Grip range: 4 - 6 mm 50 m  
Hardness: SH 78/57 / density 0,6  
Insert: 31 x 0,5 mm steel

**33.472**

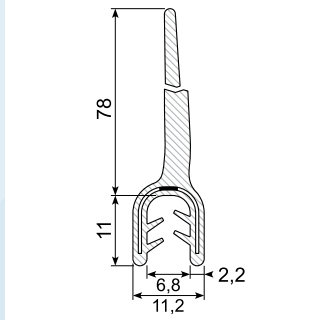

Edge trim: EPDM solid lip  
Grip range: 2 - 4 mm  
Hardness: SH 70  
Insert: 29 x 0,5 mm unbroken

**33.471**

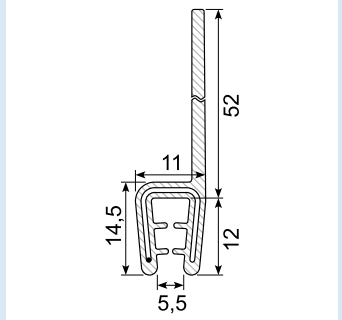

Edge trim: EPDM solid lip  
Grip range: 3 - 4 mm  
Hardness: SH 60 solid lip  
Insert: 29 x 0,76 mm wire

\* Skaffevare / Special order item

33.443 \* \*\*

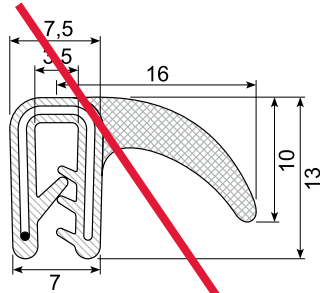

Edge trim: EPDM co-ex  
Grip range: 1 - 2 mm  
Hardness: SH 70 / density 0,55  
Insert: Wire  
Min. order: 5.500 m

33.443X

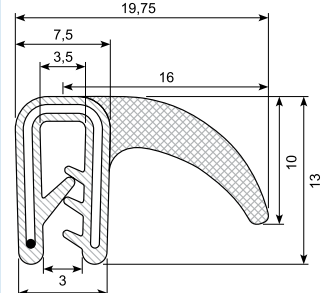

Edge trim: EPDM co-ex  
Grip range: 1 - 2 mm  
Hardness: SH 60 / density 0,6  
Insert: Wire

33.467 \*\*

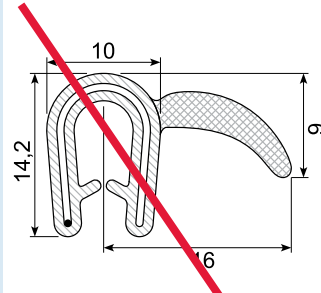

Edge trim: EPDM co-ex  
Grip range: 1,5 - 3,5 mm  
Hardness: SH 70 / density 0,65  
Insert: 29 x 0,76 mm wire  
Min. order: 6.000 m

33.383

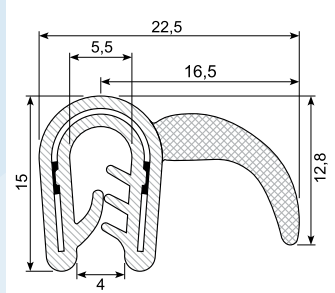

Edge trim: EPDM co-ex  
Grip range: 2 - 4 mm  
Hardness: SH 70 / density 0,6  
Insert: 30 x 0,5 steel

33.385 \* \*\*

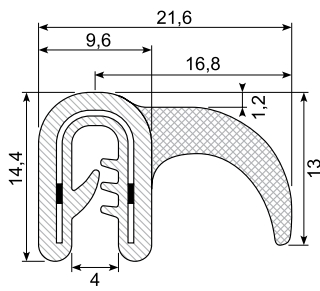

Edge trim: EPDM co-ex  
Grip range: 1 - 2,5 mm  
Hardness: SH 70 / density 0,55  
Insert: 26 x 0,5 steel unbroken  
Min. order: 9.600 m

33.466 \* \*\*

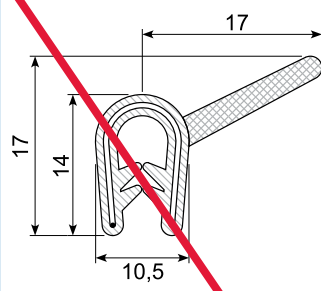

Edge trim: EPDM solid m  
Grip range: 1 - 2,5 mm  
Hardness: SH 60  
Insert: 26 x 0,76 mm wire  
Min. order: 6.000 m

33.474

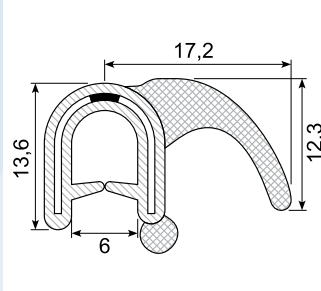

Edge trim: EPDM co-ex  
Grip range: 2 - 5 mm  
Hardness: SH 70 / density 0,6 - 0,85  
Insert: 27 mm steel

33.384 \*

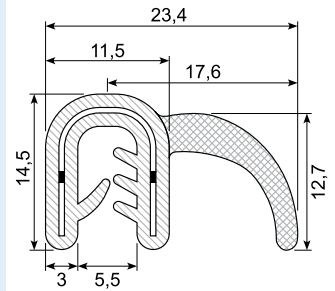

Edge trim: EPDM co-ex  
Grip range: 1,25 - 2 mm  
Hardness: SH 75 / density 0,6  
Insert: 29 x 0,5 mm steel broken  
Min. order: 5.000 m

33.439A

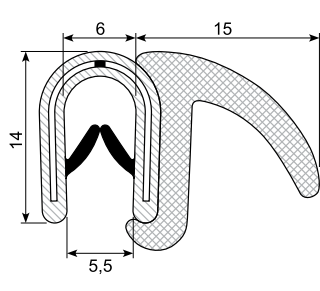

Edge trim: PVC+bi / sponge rubber  
Grip range: 1 - 4 mm  
Hardness: SH 78/57 / density 0,6  
Insert: 26 x 0,5 mm steel  
Yellow lips

33.026

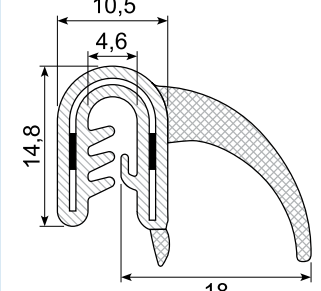

Edge trim: EPDM co-ex  
Grip range: 1,5 - 2 mm (1 - 3,5 mm)  
Hardness: SH 70 / density 0,55  
Insert: 26 x 0,76 mm wire

33.436

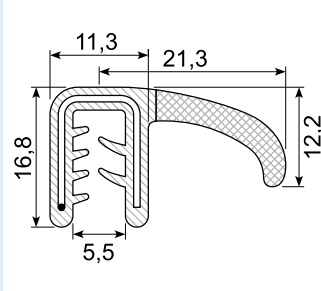

Edge trim: EPDM co-ex  
Grip range: 2 - 4 mm  
Hardness: SH 70 / density 0,6  
Insert: 33 mm wire

33.442

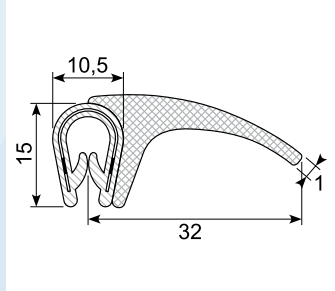

Edge trim: EPDM co-ex  
Grip range: 1 - 3 mm  
Hardness: SH 70 / density 0,65  
Insert: 29 mm steel

33.473

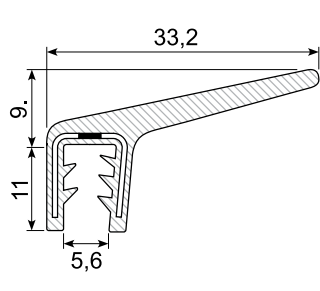

Edge trim: EPDM co-ex  
Grip range: 2 - 5 mm  
Hardness: SH 70  
Insert: 27 x 0,47 mm steel

33.462 \*

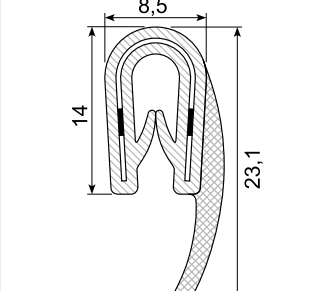

Edge trim: PVC / sponge rubber  
Grip range: 1 - 2,5 mm  
Hardness: SH 78/density 0,65 - 0,75  
Insert: 25 x 0,48 mm steel  
Min. order: 1.000 m

33.462R

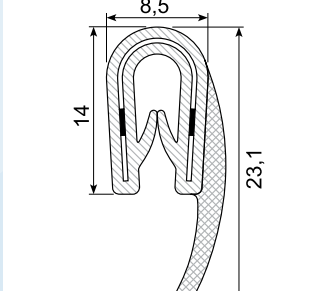

Edge trim: PVC / sponge rubber  
Grip range: 1 - 2,5 mm  
Hardness: SH 78/density 0,65 - 0,75  
Insert: 25 x 0,48 mm stainless steel

33.000

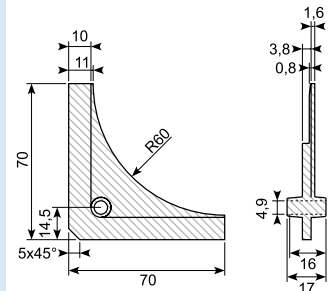

Nylon hjørnestykke  
PA6 + 30% GF  
Sikrer korrekt hjørneradius

**33.311**

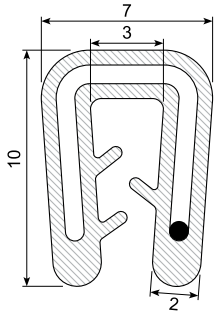

Edge trim: Black silicone  
Grip range: 1 - 2 mm  
Hardness: SH 60  
Insert: Wire 18 x 0,76 mm  
Heat resistant 200° C

**33.510**

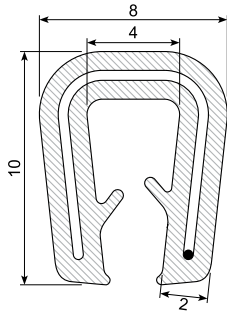

Edge trim: Black silicone  
Grip range: 1 - 3 mm  
Hardness: SH 60  
Insert: Wire 26 x 0,76 mm  
Heat resistant 200° C

**33.312**

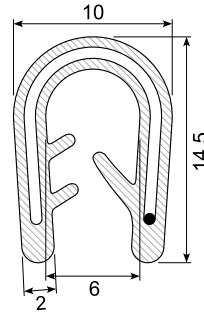

Edge trim: Silicone  
Grip range: 2 - 4 mm  
Hardness: SH 60  
Insert: Wire  
Heat resistant 200° C

**33.429**

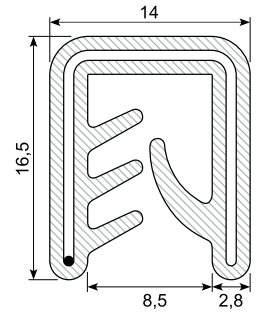

Edge trim: Black silicone  
Grip range: 3 - 6 mm (5 - 7 mm)  
Hardness: SH 60  
Insert: Wire 39 x 0,76 mm  
Heat resistant 200° C

**33.511**

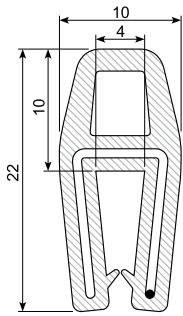

Edge trim: Silicone  
Grip range: 1,5 - 4 mm  
Hardness: SH 50  
Insert: Wire  
Heat resistant 200° C

**33.512**

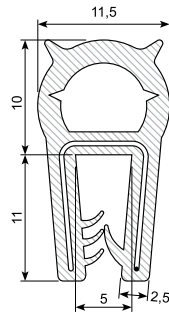

Edge trim: Silicone  
Grip range: 1 - 3,5 mm  
Hardness: SH 50  
Insert: Wire  
Heat resistant 200° C

**33.513**

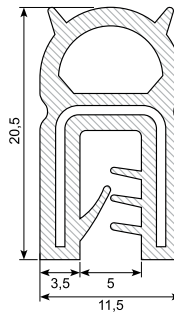

Edge trim: Silicone  
Grip range: 1,5 - 3,5 mm  
Hardness: SH 50  
Insert: Wire  
Heat resistant 200° C

**33.431A**

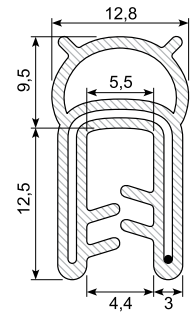

Edge trim: Silicone. Light gray  
RAL 7035  
Grip range: 2 - 4 mm  
Hardness: SH 60/60 Solid balloon  
Insert: Wire  
Heat resistant 200°C. FDA conform

**33.514**

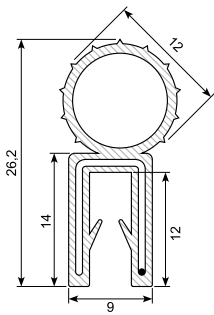

Edge trim: Silicone  
Grip range: 1,5 - 3 mm  
Hardness: SH 75  
Insert: Wire  
Heat resistant 200° C

**33.515**

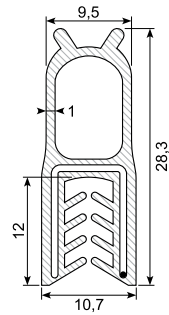

Edge trim: Silicone  
Grip range: 1 - 2,5 mm  
Hardness: SH 75  
Insert: Wire  
Heat resistant 200° C

**33.516**

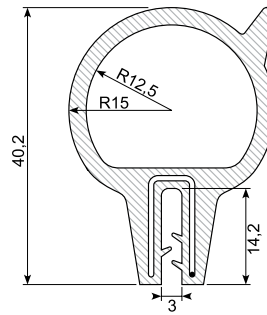

Edge trim: Silicone  
Grip range: 2 - 3 mm  
Hardness: SH 75  
Insert: Wire  
Heat resistant 200° C

**33.517**

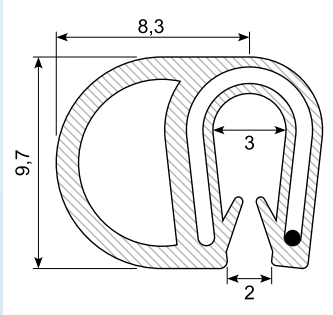

Edge trim: Silicone  
Grip range: 2 - 3 mm  
Hardness: SH 50  
Insert: Wire  
Heat resistant 200° C

**33.518 \***

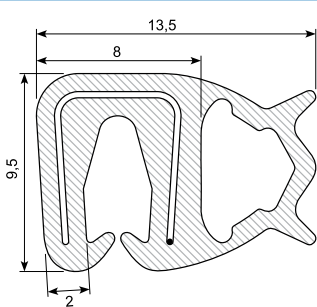

Edge trim: White silicone  
Grip range: 1,5 - 2,5 mm  
Hardness: SH 60  
Insert: Wire  
Min. order: 500 m

**33.519**

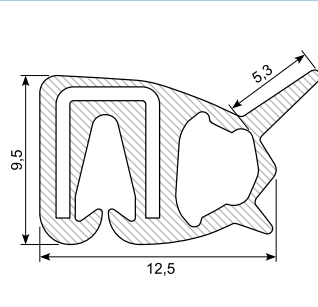

Edge trim: Silicone  
Grip range: 1 - 2 mm  
Hardness: SH 45  
Insert: Wire  
Heat resistant 200° C

**33.520 \***

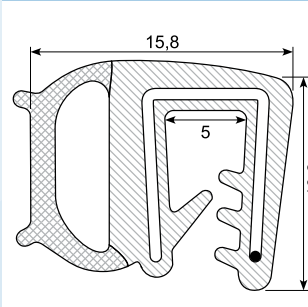

Edge trim: Silicone, co-ex.  
Color: Black and redbrown  
Grip range: 1,5 - 3 mm  
Hardness: SH 60 / density 0,4  
Insert: Wire  
Min. order: 500 m

**33.521**

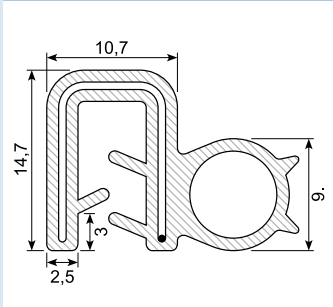

Edge trim: Silicone  
Grip range: 1,5 - 4,5 mm  
Hardness: SH 75  
Insert: Wire  
Heat resistant 200° C

\* Skaffevare / Special order item



**33.522 \***

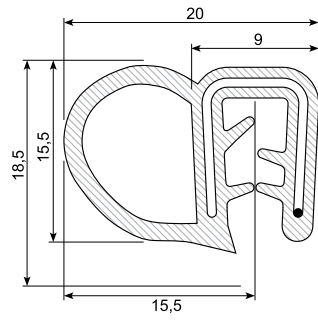

Edge trim: Silicone  
Grip range: 1 - 2,5 mm  
Insert: Wire  
Heat resistant 200° C  
Min. order: 2.000 m

**33.523 \***

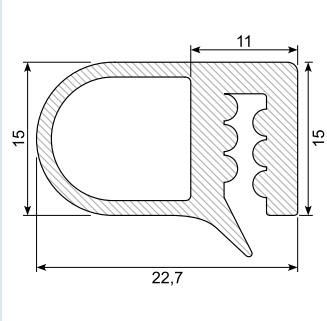

Edge trim: Silicone  
Grip range: 1,5 - 2,5 mm  
Hardness: SH 60  
Insert: Wire  
Heat resistant 200° C  
Min. order: 500 m

**33.524**

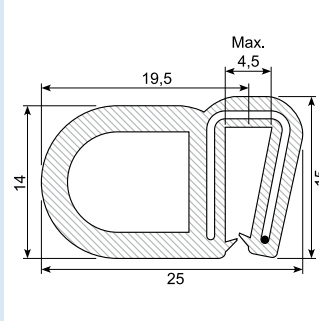

Edge trim: Silicone  
Grip range: 2 - 4 mm  
Hardness: SH 50  
Insert: Wire  
Heat resistant 200° C

**33.525**

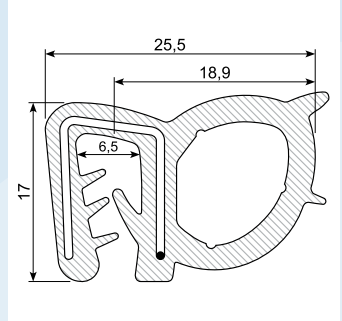

Edge trim: Silicone  
Grip range: 3 - 6 mm  
Hardness: SH 50  
Insert: Wire  
Heat resistant 200° C

**33.526 \***

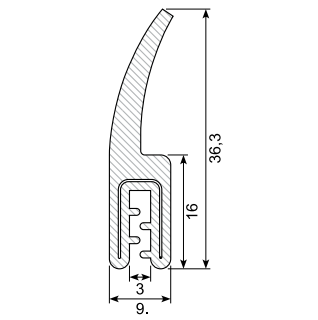

Edge trim: Silicone  
Grip range: 1 - 2,5 mm  
Hardness: SH 65  
Insert: Wire  
Heat resistant 200° C

**33.527 \***

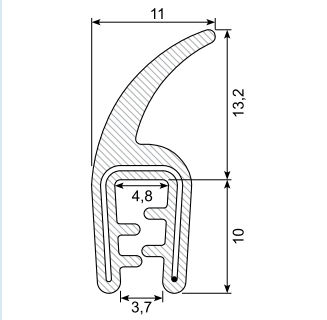

Edge trim: Silicone  
Grip range: 1 - 2,5 mm  
Hardness: SH 65  
Insert: Wire  
Heat resistant 200° C

**33.528 \***

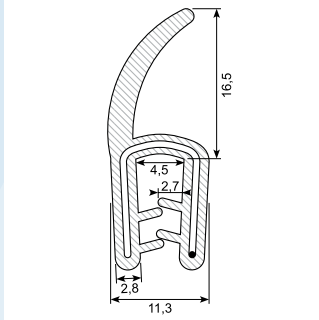

Edge trim: Silicone  
Grip range: 1 - 3 mm  
Hardness: SH 60  
Insert: Wire  
Heat resistant 200° C

**33.529 \***

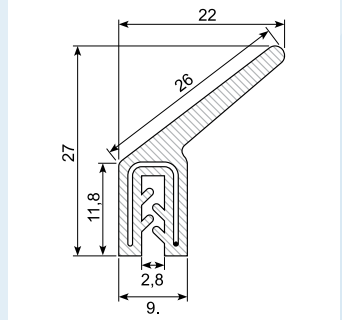

Edge trim: Silicone  
Grip range: 1 - 1,5 mm  
Hardness: SH 80  
Insert: Wire  
Heat resistant 200° C  
Min. order: 500 m

**33.530 \***

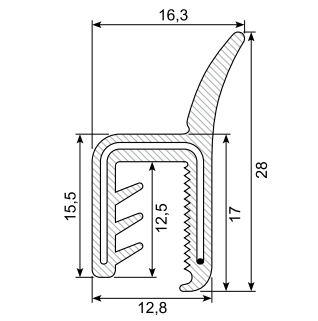

Edge trim: Silicone  
Grip range: 3,5 - 5 mm  
Hardness: SH 70  
Insert: Wire  
Heat resistant 200° C  
DIN 5510-2 S4ST2

**33.531 \***

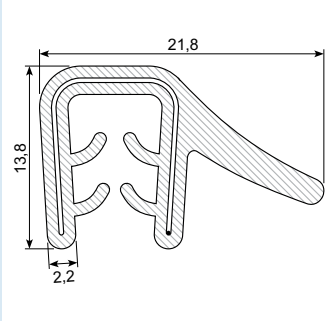

Edge trim: Silicone  
Grip range: 2,5 - 5,5 mm  
Hardness: SH 70  
Insert: Wire  
Heat resistant 200° C  
Min. order: 500 m

**33.532 \***

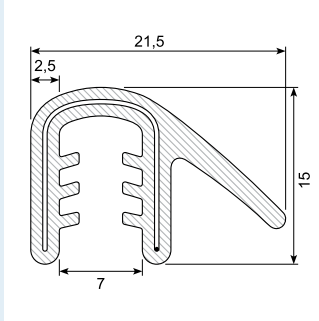

Edge trim: Silicone  
Grip range: 5,5 - 6,5 mm  
Hardness: SH 65  
Insert: Wire  
Heat resistant 200° C

## POM-profiler / POM edge trims

### POM-profiler

- En meget mere fleksibel opbygning med dets hukommelseffekt
- POM-profiler vejer meget mindre end profiler med metal indlæg
- POM-profiler kan ikke ruste eller oxidere
- Fremstillingen af POM-profiler er meget nemmere end profiler med metal indlæg
- Større sikkerhed ved montering. Man undgår rifter fra skarpe metalstykker
- POM-indlæg er ikke ledende som metal og kan derfor anvendes til beskyttelse eller overflade materiale

### POM-profiles

- A much more flexible structure with its memory effect
- POM-supported profiles is much lighter than metal-based profiles
- Over time, no metallic corrosion and oxidize
- Processing of manufacturing for POM-backed profiles is much easier than metal-backed profiles
- During installation does not damage human health such as sinking or cutting
- POM is not conductive support material, such as metal supports therefore wherever used in protection and coating material

33.409POM

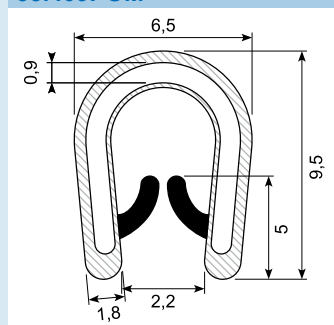

Edge trim: PVC + bi  
Grip range: 0,5 - 2 mm  
Hardness: SH 75 / 65  
Insert: POM plastic  
No rust. Easy cutting.

33.308POM

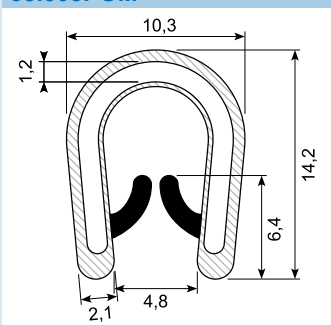

Edge trim: PVC + bi  
Grip range: 2 - 4,5 mm  
Hardness: SH 75 / 65  
Insert: POM plastic  
No rust. Easy cutting.

33.200POM

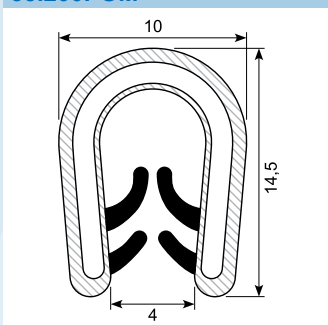

Edge trim: PVC + bi  
Grip range: 1 - 4 mm  
Hardness: SH 75 / 65  
Insert: POM plastic  
No rust. Easy cutting.

33.201POM

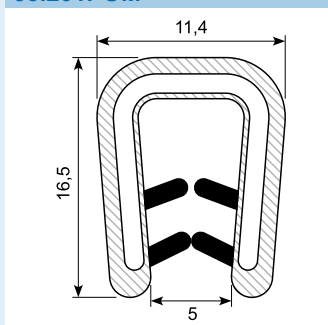

Edge trim: PVC + bi  
Grip range: 2 - 4 mm  
Hardness: SH 75 / 65  
Insert: POM plastic  
No rust. Easy cutting.

33.202POM

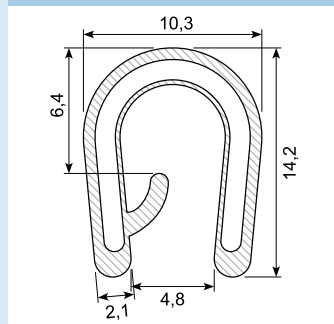

Edge trim: PVC + bi  
Grip range: 4 - 6 mm  
Hardness: SH 75 / 65  
Insert: POM plastic  
No rust. Easy cutting.

33.203POM

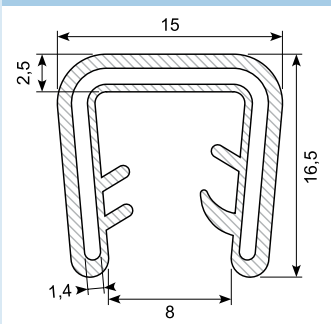

Edge trim: PVC + bi  
Grip range: 6 - 8 mm  
Hardness: SH 75 / 65  
Insert: POM plastic  
No rust. Easy cutting.

33.210POM

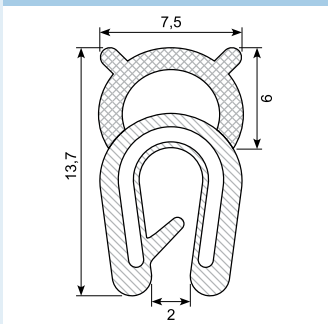

Edge trim: TPE co-ex  
Grip range: 1 - 2 mm  
Hardness: SH 75 / density 0,65  
Insert: POM plastic  
No rust. Easy cutting.

33.211POM

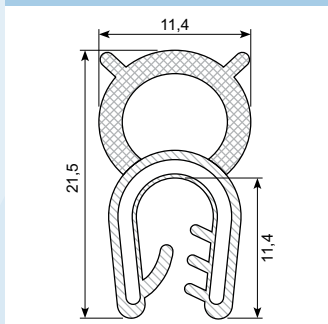

Edge trim: TPE co-ex  
Grip range: 1 - 4 mm  
Hardness: SH 75 / density 0,65  
Insert: POM plastic  
No rust easy cutting

33.212POM

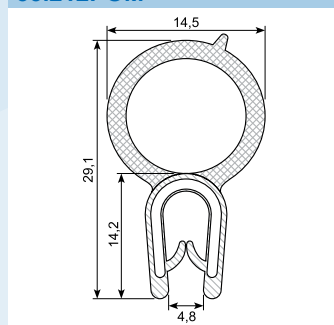

Edge trim: TPE co-ex  
Grip range: 2 - 4 mm  
Hardness: SH 75 / density 0,65  
Insert: POM plastic  
No rust easy cutting

33.218POM

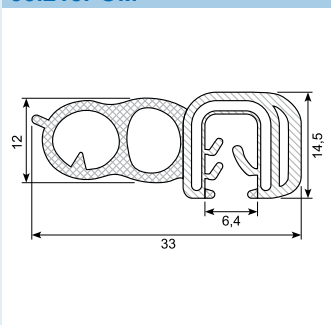

Edge trim: TPE co-ex  
Grip range: 3 - 5 mm  
Hardness: SH 75 / density 0,65  
Insert: POM plastic  
No rust easy cutting

33.216POM

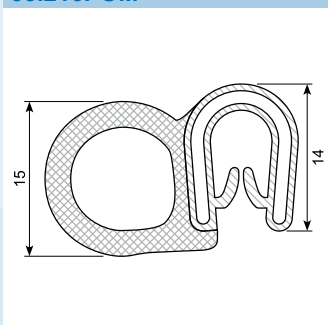

Edge trim: TPE co-ex  
Grip range: 1 - 4 mm  
Hardness: SH 75 / density 0,65  
Insert: POM plastic  
No rust easy cutting

33.217POM

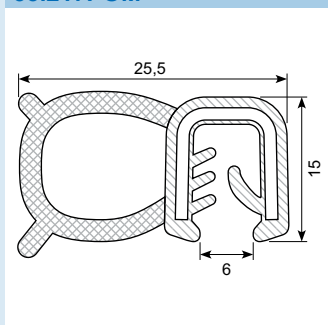

Edge trim: TPE co-ex  
Grip range: 4 - 6 mm  
Hardness: SH 75 / density 0,65  
Insert: POM plastic  
No rust easy cutting

33.213POM

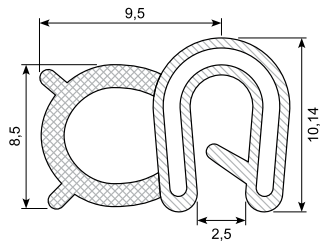

Edge trim: TPE co-ex  
 Grip range: 1 - 2 mm  
 Hardness: SH 75 / density 0,65  
 Insert: POM plastic  
 No rust easy cutting

33.214POM

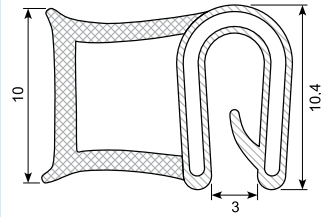

Edge trim: TPE co-ex  
 Grip range: 1 - 2 mm  
 Hardness: SH 75 / density 0,65  
 Insert: POM plastic  
 No rust easy cutting

33.215POM

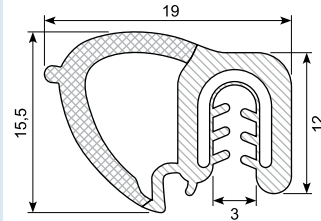

Edge trim: TPE co-ex  
 Grip range: 1 - 2 mm  
 Hardness: SH 75 / density 0,65  
 Insert: POM plastic  
 No rust easy cutting

33.220POM

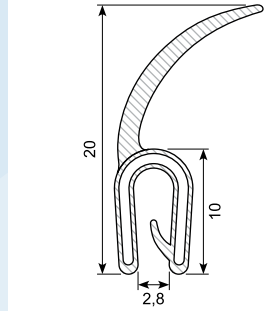

Edge trim: TPE  
 Grip range: 1 - 2 mm  
 Hardness: SH 75 / density 0,65  
 Insert: POM plastic  
 No rust easy cutting

33.221POM

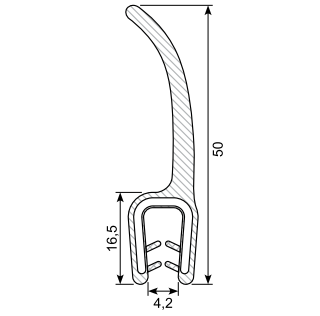

Edge trim: TPE  
 Grip range: 2 - 4 mm  
 Hardness: SH 75 solid  
 Insert: POM plastic  
 No rust easy cutting

33.424 \*

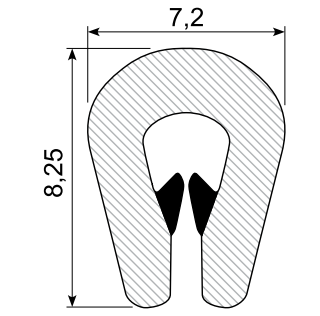

Edge trim: TPE + bi  
 Grip range: 0,8 - 2,5 mm  
 Hardness: SH 87 / 65 - 70  
 Insert: None  
 Alternative 33.424TPE

33.424TPE

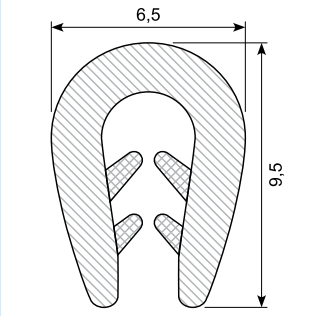

Edge trim: TPE + bi  
 Grip range: 1 - 2 mm  
 Hardness: SH 90 / 50  
 Insert: None

33.417TPE

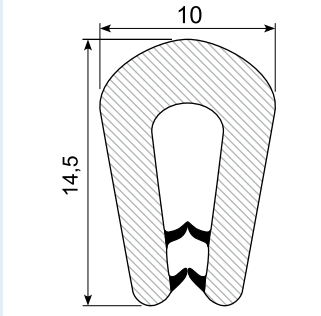

Edge trim: TPE + bi  
 Grip range: 1 - 4 mm  
 Hardness: SH 90 / 50  
 Insert: None

## Gummisnor / Rubber cord profiles

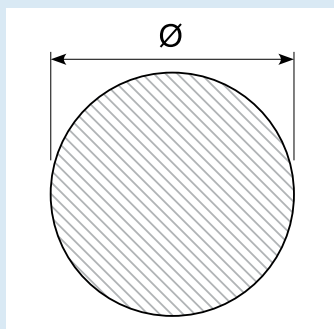

Black EPDM  
Shore A 65 - 70

Art	Ø mm
30.101 *	1
30.101.25 *	1,25
30.101.5	1.5
30.102	2
30.102E	2 (single cord)
30.103E *	3
30.104E *	4
30.104.5E	4,5
30.105E	5
30.106E	6
30.107E *	7
30.108E	8
30.109E	9
30.110E	10
30.112E *	12
30.113E	13
30.114E *	14
30.115E *	15
30.116E *	16
30.117E	17
30.118E	18
30.119E	19
30.120E	20
30.121E	21
30.122E	22
30.124E	24
30.125E *	25
30.135E	35 (SH 75)

Black CR  
Shore A 60

Art	Ø mm
30.103CR *	3
30.103.5CR *	3,5
30.104CR *	4
30.104.5CR *	4,5
30.105CR *	5
30.105.3CR *	5,3
30.105.7CR *	5,7
30.106CR *	6
30.106.5CR *	6,5
30.107CR *	7
30.107.5CR *	7,5
30.108CR *	8
30.108.4CR *	8,4
30.109CR *	9
30.109.5CR *	9,5
30.110CR *	10
30.111CR *	11
30.112CR *	12
30.113CR *	13
30.114CR *	14
30.115CR *	15
30.116CR *	16
30.118CR	18
30.120CR *	20
30.122CR *	22
30.125CR *	25
30.130CR *	30
30.132CR *	32
30.140CR *	40

Black NBR  
Shore A 65

Art	Ø mm
30.103NBR	3
30.103.5NBR *	3,5
30.104NBR *	4
30.104.5NBR *	4,5
30.105NBR	5
30.105.3NBR *	5,3
30.105.7NBR *	5,7
30.106NBR *	6
30.106.5NBR *	6,5
30.107NBR *	7
30.107.5NBR *	7,5
30.108NBR *	8
30.108.4NBR *	8,4
30.109NBR *	9
30.109.5NBR *	9,5
30.110NBR *	10
30.111NBR *	11
30.112NBR *	12
30.113NBR *	13
30.114NBR *	14
30.116NBR *	16
30.118NBR *	18
30.120NBR *	20
30.122NBR *	22
30.125NBR *	25
30.130NBR *	30
30.132NBR *	32
30.140NBR *	40

White SILICONE  
Shore A 60

Art	Ø mm
30.103SIH *	3
30.104SIH *	4
30.106SIH *	6
30.108SIH	8

## Elastiksnor / Rubber cord

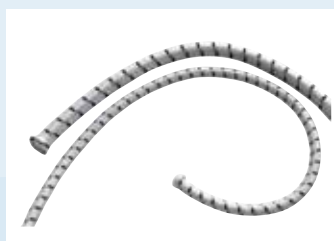

Art.	Ø (mm)
50.260-4	4
50.260-5	5
50.260-6	6
50.260-8	8
50.260-10	10

\* Skaffevare / Special order item

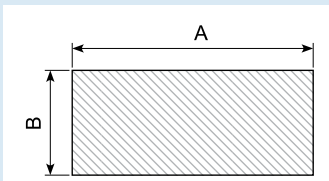

Material: EPDM

Art.	A (mm)	B (mm)	Hardness	Min. order (m)	Adhesive
30.29168	12	1	SH 65	2.000	X
<del>30.A018615</del>	<del>18,6</del>	<del>1,5</del>	<del>SH 65</del>		
30.601 *	65	2,5	SH 65	500	
30.600	30	3	SH 65		
30.602	50	3	SH 65		
30.12932-3 *	50	4	SH 60	600	
30.A02005	20	5	SH 65		
30.A02505	25	5	SH 65		
30.A03305	33	5	SH 65		
30.A05005	50	5	SH 65		
30.A06705	67	5	SH 65		
30.A07505	75	5	SH 65		
30.A10005	100	5	SH 65		
30.23464	150	5	SH 65		X
30.A03006	30	6	SH 65		
30.A05808	58	8	SH 65		
30.12932-4 *	23	10	SH 60	500	
30.A03310	33	10	SH 65		
30.A05010	50	10	SH 65		
30.A06710	67	10	SH 65		
30.A10010	100	10	SH 65		

Other sizes can be obtained on request.

30.262S

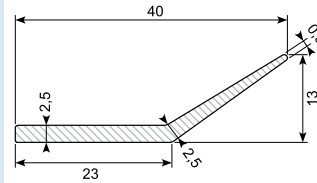

Material: EPDM black  
Hardness: SH 65 - 75

30.WI660

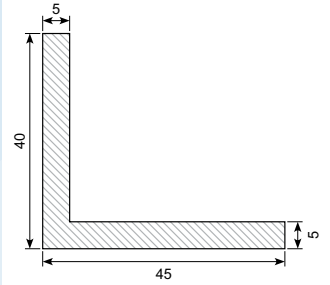

L-profil  
Internal: 35 x 40 x 5 mm  
External: 40 x 45 x 5 mm

30.WI747

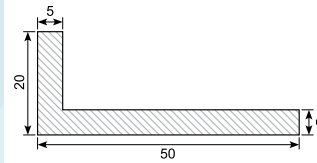

Material: EPDM  
Hardness: SH 60

30.9691-2 \*

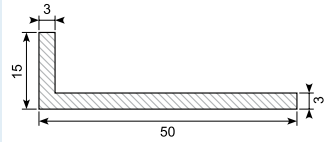

Material: White EPDM  
Min. order: 504 m

30.7367

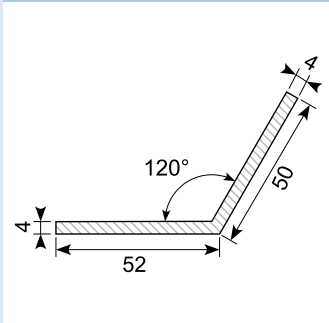

Material: CR black  
Hardness: SH 65  
Conditional oil resistant

30.9691-5 \*

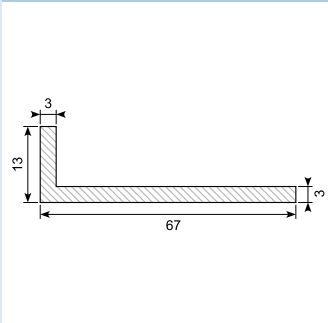

Material: White EPDM  
Hardness: SH 65  
Min. order: 504 m

30.7696

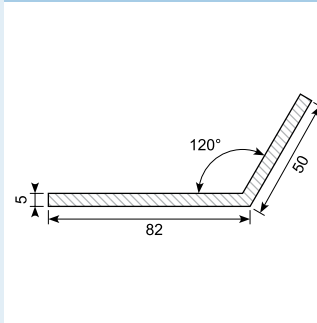

Material: CR black  
Hardness: SH 65  
Conditional oil resistant

30.12759

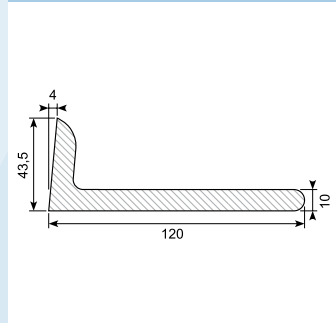

Material: Black EPDM  
Hardness: SH 60A

30.OT1024 / 30.OT1024B

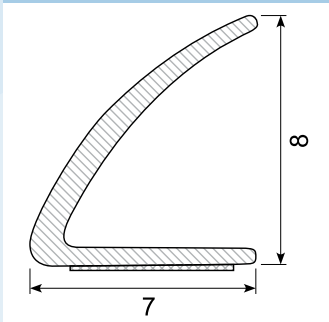

Material: Silicone with adhesive  
Hardness: SH 60  
30.OT1024 white  
30.OT1024B black  
30.OT1024KPC transparent

30.216S

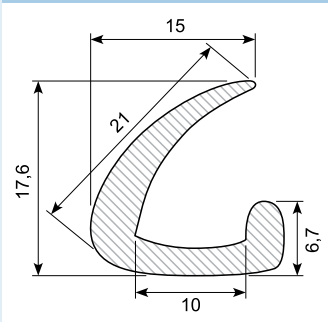

Material: EPDM black  
Hardness: SH 65

30.218S

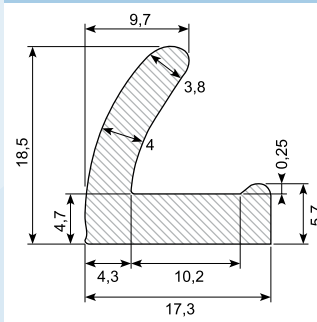

Material: EPDM black  
Hardness: SH 75 - 81

30.220L

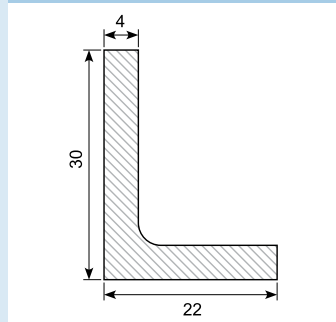

Material: CR black  
Hardness: SH 65  
Length: 6,5 m  
Conditional oil resistant

\* Skaffevare / Special order item

# Specialprofiler / Special profiles

30.331

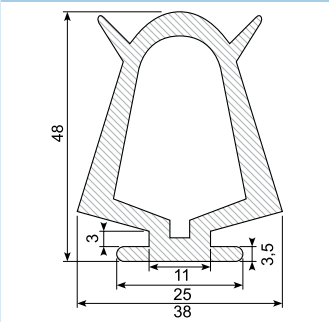

Material: EPDM black  
Hardness: SH 70

30.9996-10

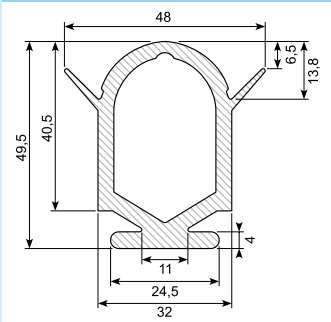

Material: EPDM  
Hardness: SH 70

41.675A - 41.674A

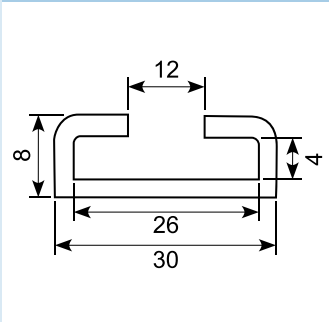

Material: Aluminium  
41.675A: 5,2 m, untreated  
41.674A: 5 m, anodized

39.1208P

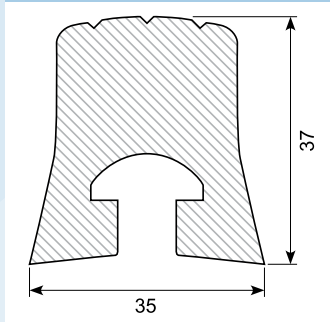

Fender profile with channel  
Material: PE  
Length: 3 m

30.12957-1 \*\*

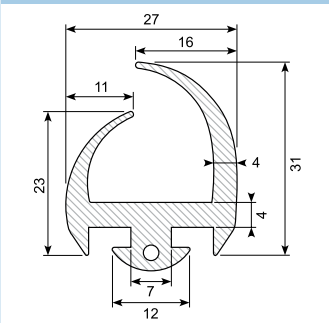

Material: EPDM  
Hardness: SH 65  
Length: 2,5 m

30.7933

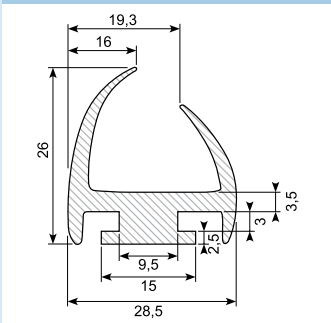

H-profile for aluminium rail  
Material: EPDM  
Hardness: SH 70

30.12957-2 \*\*

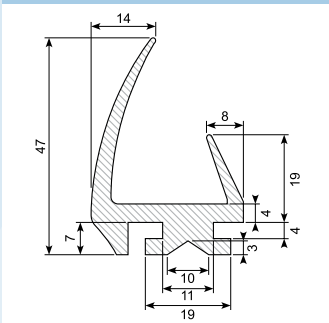

Material: EPDM  
Hardness: SH 65  
Length: 4,3 m

30.7932

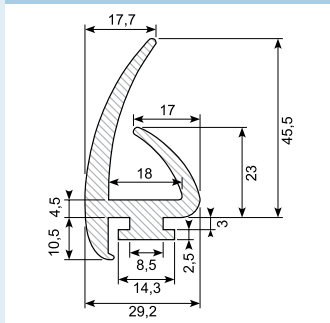

Rubber profile for alu. track  
Material: EPDM  
Hardness: SH 70

30.7935 \*\*

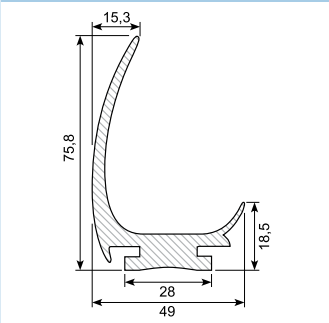

Material: EPDM black  
Hardness: SH 65  
Length: 2,8 m  
Min. order: 120 m

30.7853X

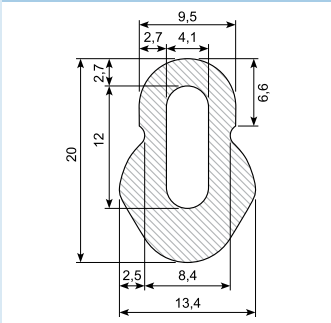

Material: Black EPDM

30.7652

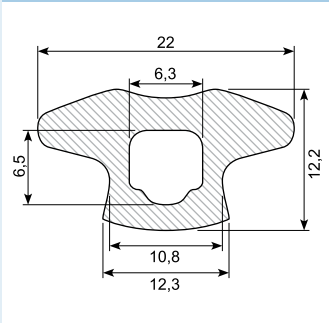

Rubber profile  
Material: EPDM  
Hardness: SH 65

30.333

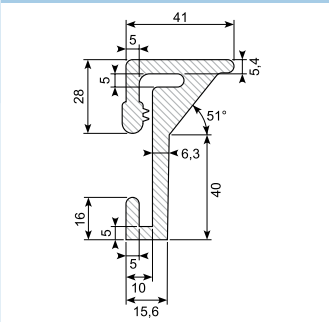

L-profile  
Material: EPDM  
Hardware: SH 70  
Roll of 50 m

41.333S

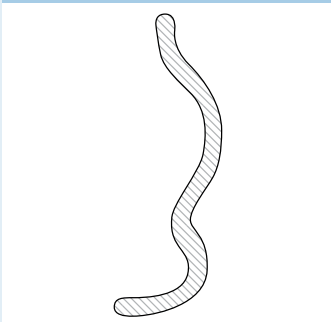

Steel profile for mounting of rubber profile 30.333  
Length: 2,6 m

30.8469 \*

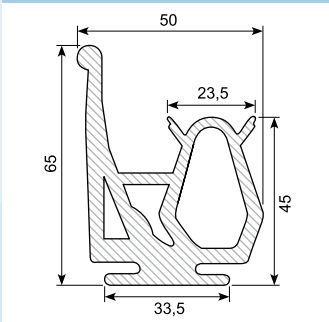

Rubber profile with drip cap  
For loading tail board  
Material: EPDM  
Hardness: SH 67  
Length: 8 m  
Min. order: 80 m

41.678

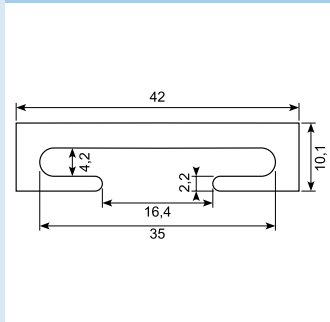

Alu c-profil 42 x 10 mm  
Length 5,2 m  
Fits to 30.8469

30.325X

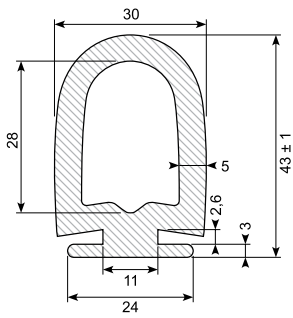

Material: EPDM black  
Hardness: SH 65  
Length: 5 m

30.324S

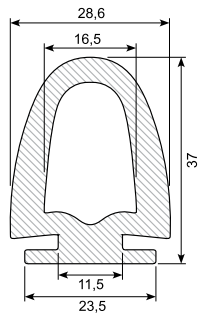

Material: EPDM black  
Hardness: SH 65  
Length: 5 m

30.324SB

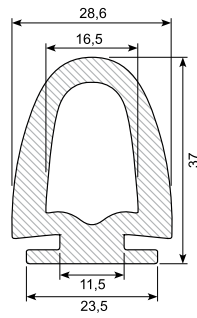

Material: EPDM black  
Hardness: SH 45 (soft)  
Length: 5 m

30.7649-8 \*

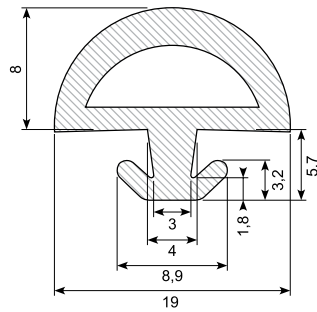

D-weatherstrip  
Material: EPDM Black  
Hardness: SH 60  
Min. order: 1.000 m

30.7649

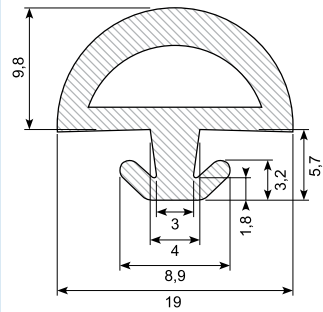

D-weatherstrip  
Material: EPDM Black  
Hardness: SH 60

30.7649-12 \*

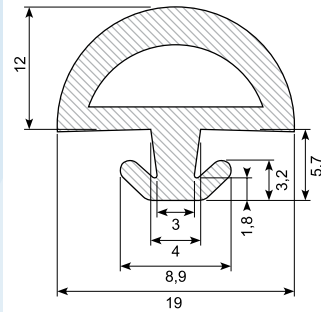

D-weatherstrip  
Material: EPDM Black  
Hardness: SH 60  
Min. order: 1.000 m

30.12957-3

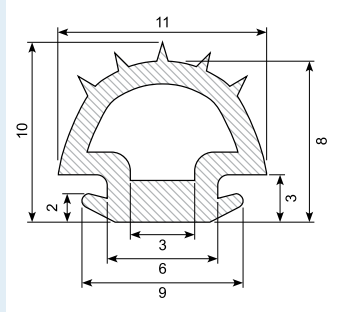

Material: EPDM  
Hardness: SH 60

30.14098-2

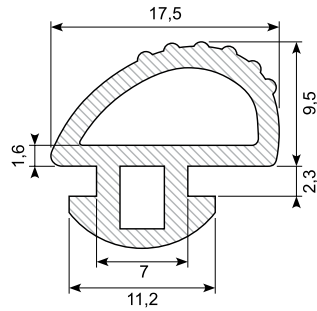

Material: EPDM  
Hardness: SH 60A

30.9691-3

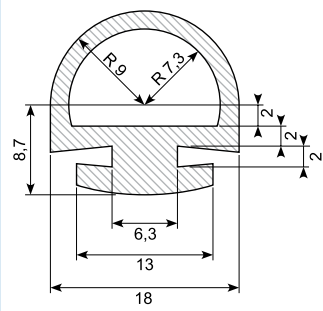

Material: Black EPDM  
Hardness: SH 65

30.7650

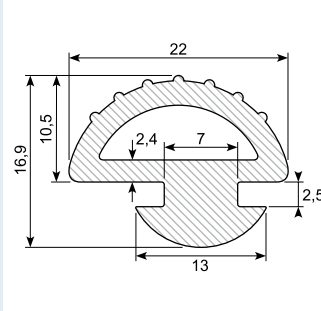

D-weatherstrip  
Material: EPDM  
Hardness: SH 70

30.5881

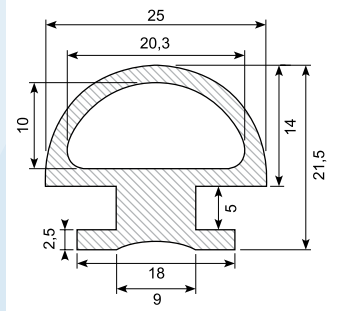

Material: CR black  
Hardness: SH 65  
Conditional oil resistant

30.2151 \*

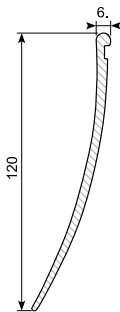

Skirt profile  
Hardness: PVC white  
Roll of 14 m  
Min. order: 560 m

30.6648

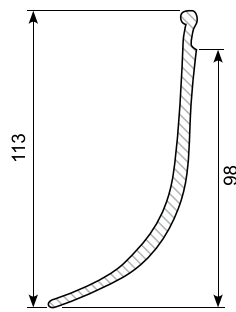

Skirt profile  
Hardness: SH 75  
30.6648: Black EPDM  
30.6648G: Grey TPE  
30.6648S: Black TPE

30.2151S \*

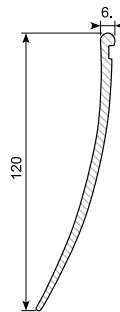

Material: Black PVC  
Hardness: SH 75 - 80  
Min. order: 280 m

30.2566

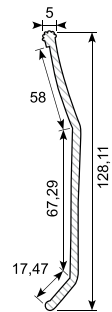

Skirt profile  
Material: PVC black  
Hardness: SH 80  
Height: 125 mm  
Length: 1 m  
Roll of 64 m

\* Skaffevare / Special order item

**30.257S**

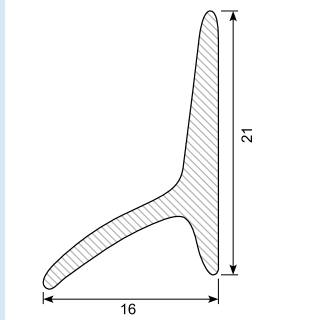

Material: EPDM black  
Hardness: SH 65

**30.258 \***

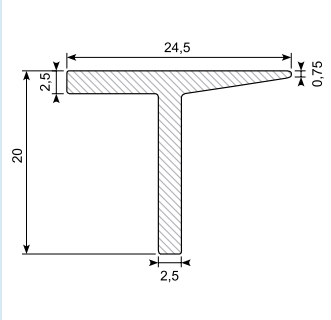

Material: EPDM black

**30.5560 \***

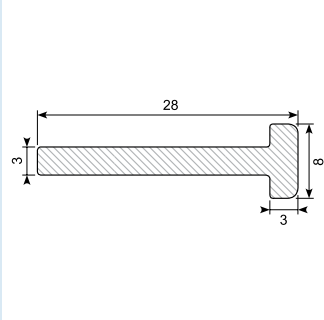

Material: EPDM black  
Hardness: SH 65  
Min. order: 450 m

**30.7780/4**

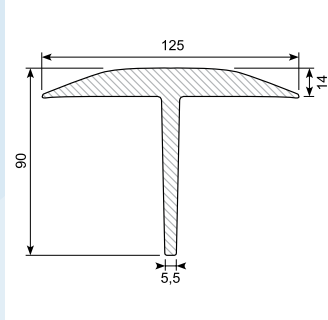

Material: EPDM black  
Hardness: SH 65  
Length: 4 m

**30.7300 - 30.7300/4**

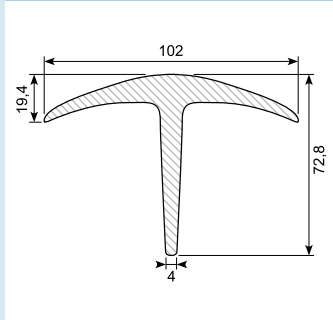

Material: EPDM black  
Hardness: SH 65  
Length 30.7300: 3 m  
Length 30.7300/4: 4 m

**30.7300/4Y \***

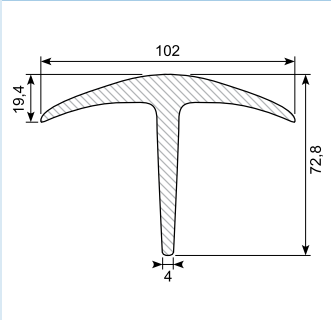

Material: EPDM yellow  
Hardness: SH 65  
Min. order: 64 m

**30.6944 \***

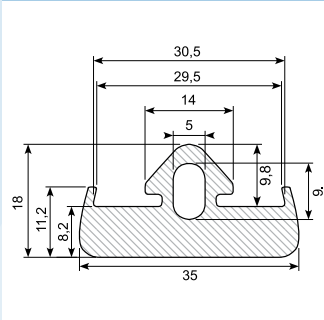

Material: EPDM black  
Hardness: SH 65  
Min. order: 200 m

**30.5550M**

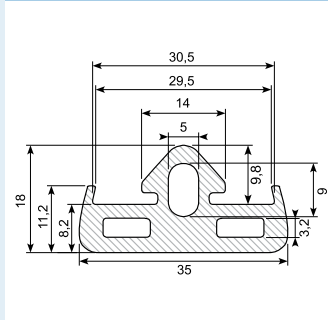

Material: EPDM black  
Hardness: SH 65

**30.2653 \***

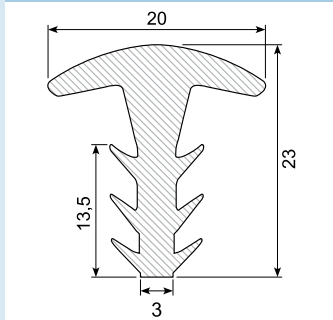

Material: EPDM black  
Hardness: SH 65  
Min. order: 1.000 m

**30.5981**

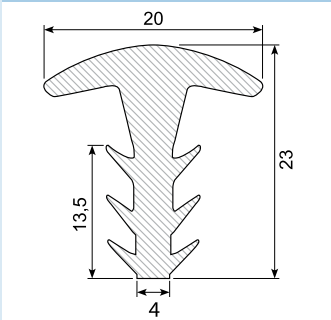

Material: EPDM black  
Hardness: SH 65

**30.8199**

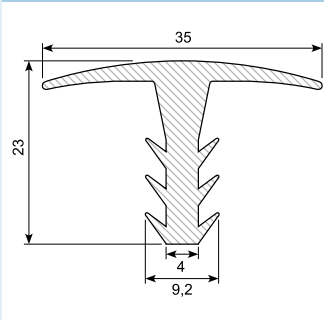

Material: EPDM black  
Hardness: SH 65  
Length: 4 m

**30.8199W**

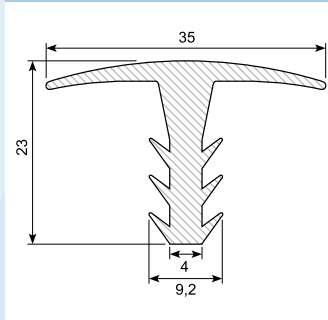

Material: EPDM white  
Hardness: SH 65  
Length: 4 m  
Min. order: 223 m

**30.6759**

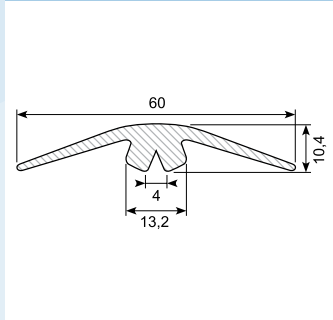

Material: EPDM black  
Hardness: SH 65

**30.7770 \***

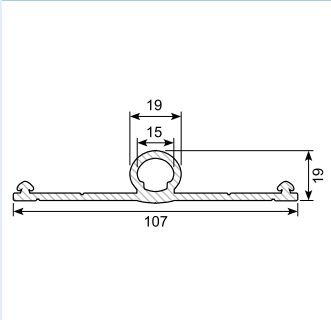

Material: EPDM black  
Hardness: SH 65  
Min. order: 100 m



30.314S

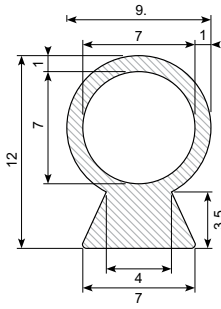

Rubber profile  
Material: EPDM  
Hardness: SH 60 / 65

30.7651

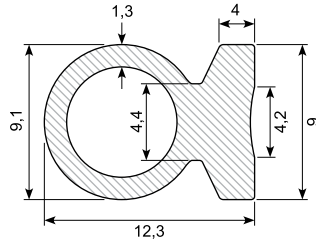

Balloon profile  
Material: EPDM  
Hardness: SH 65

30.313

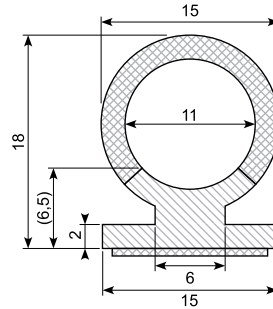

Co-ex profile  
Material: EPDM / sponge rubber  
Hardness: SH 80

30.7648

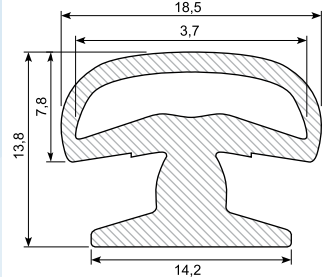

Material: EPDM black  
Hardness: SH 65

30.7106 \*

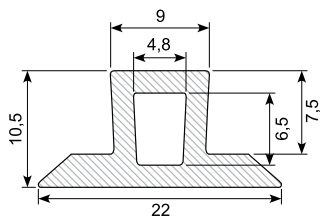

Material: SBR black  
Hardness: SH 65  
Min. order: 1.000 m

30.315S

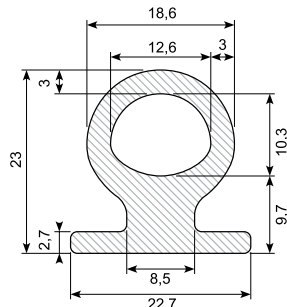

Material: EPDM black  
Hardness: SH 65  
Length: 10 m  
OBS does not fit 41.675A

30.315SB

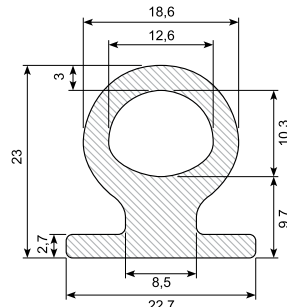

Material: EPDM black  
Hardness: SH 45  
Length: 10 m  
OBS does not fit 41.675A

30.7613 \*

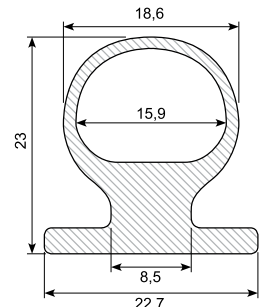

Material: EPDM black  
Hardness: SH 60  
Min. order: 500 m

30.50967 \*

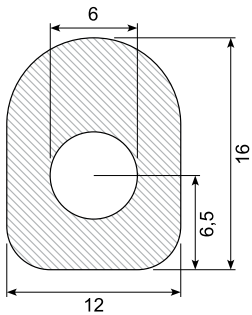

Material: NBR black  
Hardness: SH 65  
Min. order: 500 m  
Oil resistant

30.13841

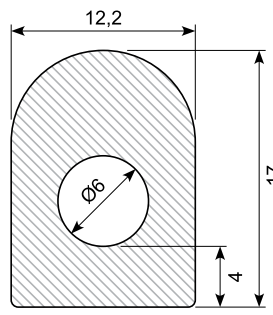

Material: Black NBR  
Hardness: SH 45A  
Oil resistant

30.14053

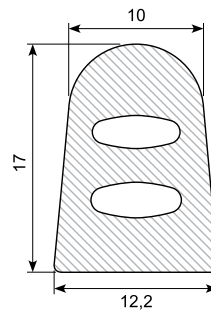

Material: Black NBR  
Hardness: SH 50A  
Oil resistant

30.OT3354

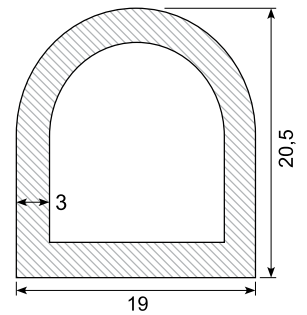

Material: Silicone white  
Hardness: SH 60

30.7645 \*

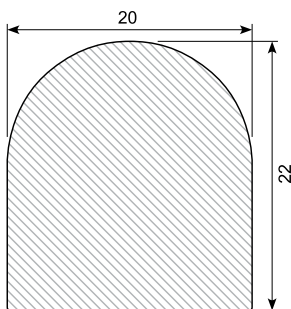

Material: EPDM black  
Hardness: SH 45  
Min. order: 50 m

30.13421

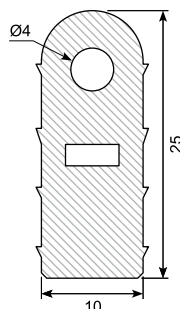

Material: EPDM  
Hardness: SH 65

30.7559

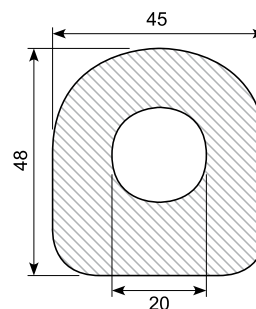

Material: NBR black  
Hardness: SH 60  
Oil resistant

# Specialprofiler / Special profiles

30.14130

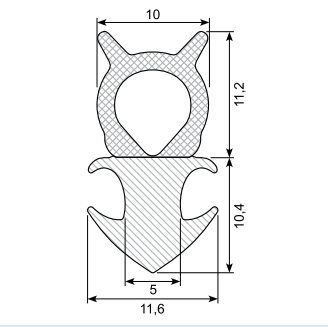

Co-ex profile  
Material: EPDM  
Hardness: SH 70 / density 85-95

30.190

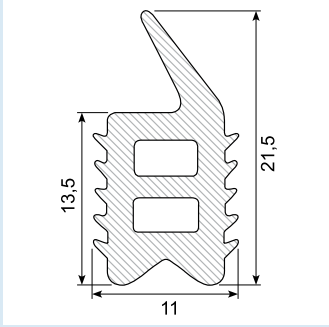

Material: PVC  
Hardness: SH 57

30.8270

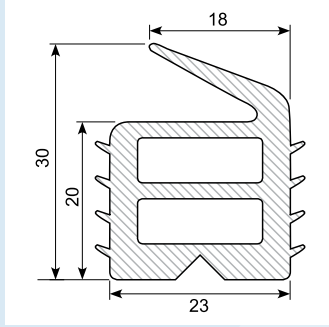

Material: EPDM black  
Hardness: SH 57

30.OT1387 \*

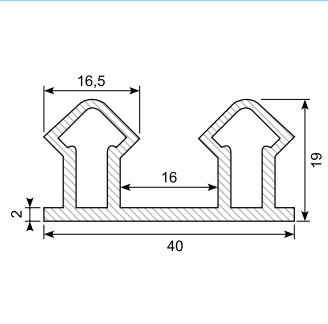

Material: Silicone grey  
Hardness: SH 60  
Min. order: 40 m

30.OT3272 \*

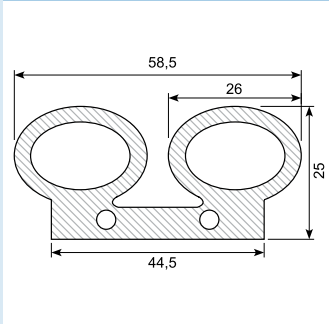

Material: Silicone blue  
Hardness: SH 60  
Min. order: 50 m

32.8518

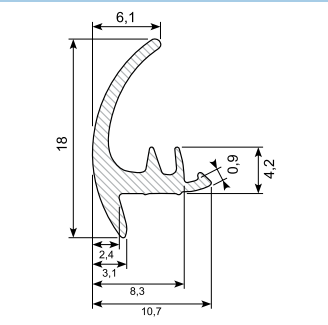

End-stop profile  
Material: EPDM  
Hardness: SH 65  
Roll of 50 m

32.8518W \*

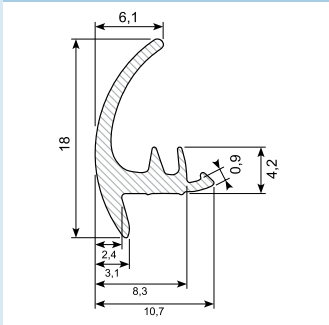

Color: White, RAL 9003  
Material: EPDM  
Hardness: SH 60  
Min. order: 1.500 m

32.8516

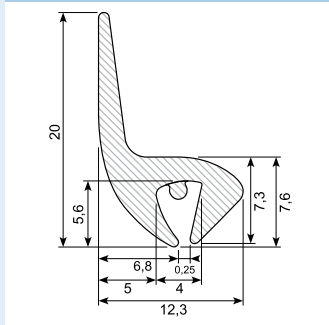

End-stop profile  
Material: EPDM  
Hardness: SH 65  
Roll of 50 m

32.8517

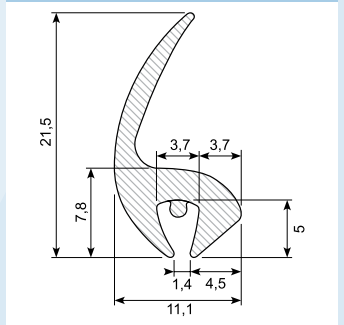

End-stop profile  
Material: EPDM  
Hardness: SH 65  
Roll of 50 m

32.8520

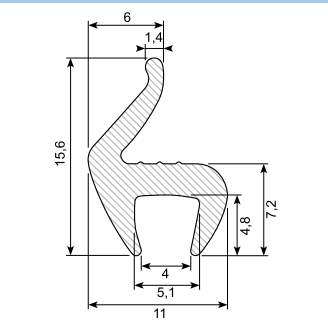

Universal end-stop profile  
Material: EPDM  
Hardness: SH 65  
Roll of 50 m

31.369

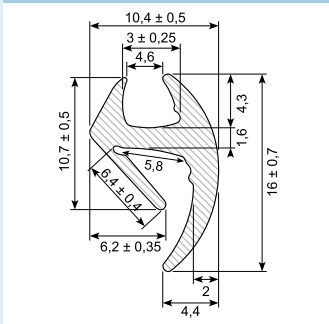

End-stop profile  
Material: EPDM black  
Hardness: SH 65

32.8519

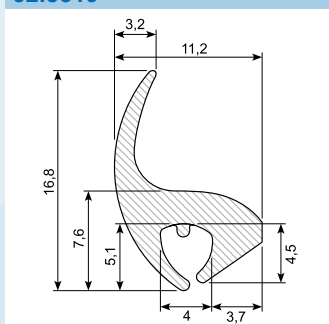

End-stop profile  
Material: EPDM  
Hardness: SH 65  
Roll of 50 m

30.12553-2

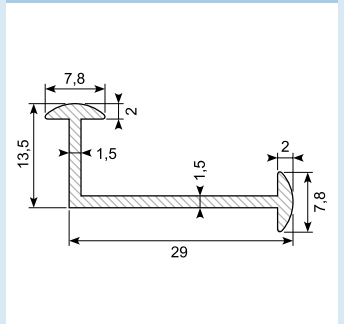

Material: Black EPDM  
Hardness: SH 60A

\* Skaffevare / Special order item

30.798

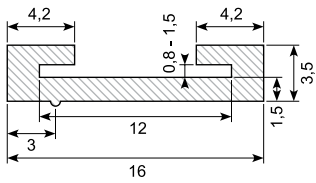

Material: EPDM black  
Hardness: SH 65

30.14163-1

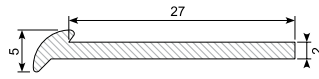

Material: EPDM  
Hardness: SH 65

30.144

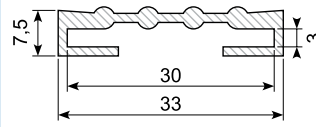

Material: EPDM black  
Hardness: SH 60

30.5179

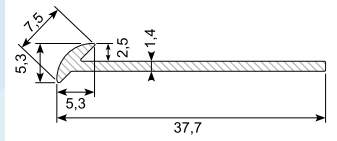

Material: EPDM

30.141

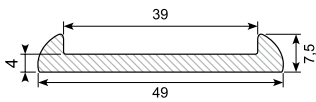

Material: EPDM  
Hardness: SH 60

30.142S

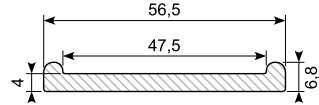

Material: EPDM black  
Hardness: SH 65

30.14163

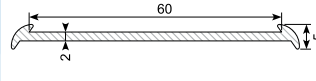

Material: EPDM  
Hardness: SH 65

30.8331

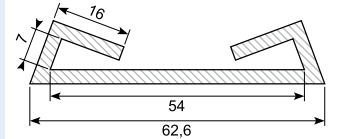

Material: EPDM black  
Hardness: SH 65

30.145W \*

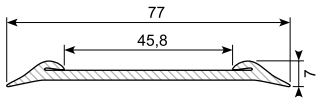

Material: EPDM white  
Hardness: SH 65  
Min. order: 300 m

30.145 \*

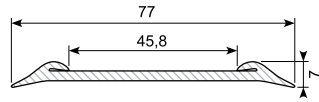

Material: EPDM black  
Hardness: SH 70  
Min. order: 200 m

30.13447-8 \*

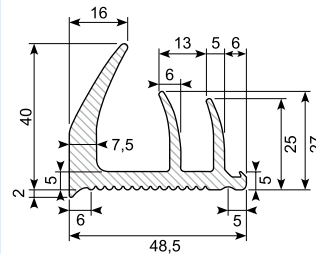

Container profile  
Material: EPDM  
Hardness: SH 70  
Length: 2,5 m  
Min. order: 500 m

54.710290 \*

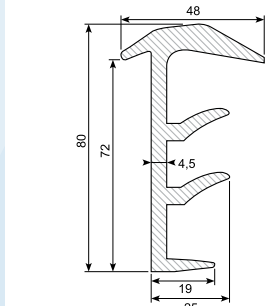

Material: EPDM black  
Hardness: SH 65  
Length: 10 m  
Min. order: 10 m

30.7663

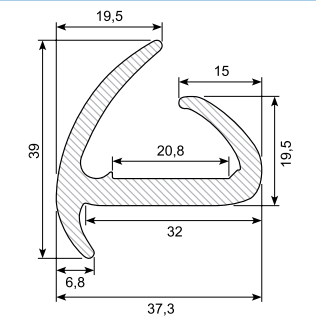

Material: EPDM black  
Hardness: SH 65  
Length: 5 m

30.340

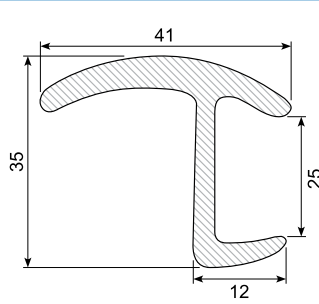

Material: EPDM black  
Hardness: SH 50  
Length: 3 m

30.2438

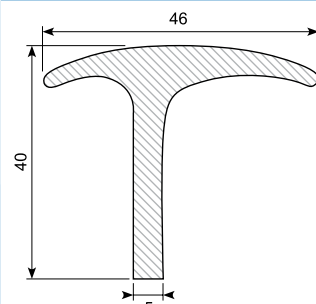

Material: EPDM black  
Hardness: SH 65  
Length: 2,2 m

30.4437 \*

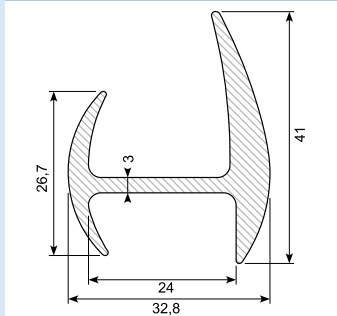

Material: Black EPDM  
Hardness: SH 60  
Min. order: 85 m

30.7411

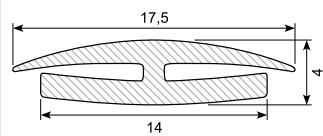

Material: EPDM black  
Hardness: SH 65  
Grip range: 1 - 1,5 mm

30.13062 \*

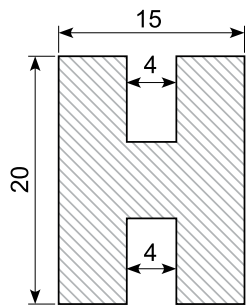

Material: EPDM  
Hardness: SH 65  
Min. order: 500 m

34.7528-2H \*

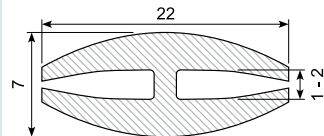

Material: PVC white  
Min. order: 250 m

34.7528-2

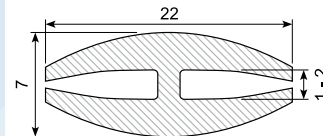

Material: PVC grey

34.3546

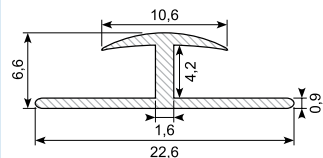

Material: White PVC

30.762

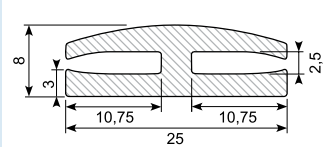

Material: EPDM black  
Hardness: SH 65

31.072

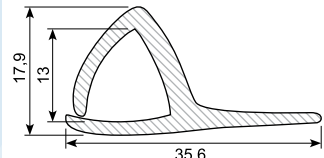

Material: EPDM black  
Hardness: SH 65

30.7266 \*

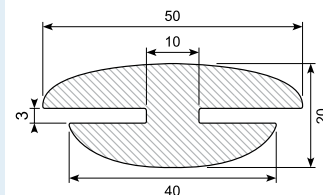

Material: EPDM black  
Hardness: SH 65  
Min. order: 50 m

30.12932-2 \*

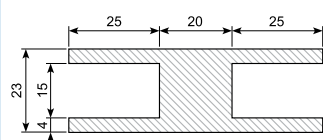

Material: Black EPDM  
Hardness: SH 60  
Min. order: 400 m

30.29300-130 \*

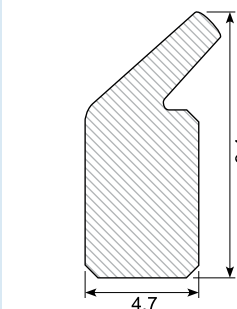

Material: CR black  
Hardness: SH 65  
Min. order: 100 m  
Conditional oil resistant

30.29300-129 \*

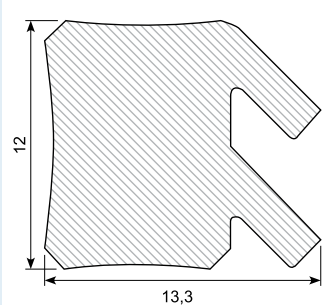

Material: Black CR  
Hardness: SH 65  
Min. order: 300 m  
Conditional oil resistant

30.16688

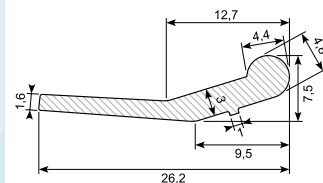

Material: EPDM  
Hardness: SH 70

30.7811 \*

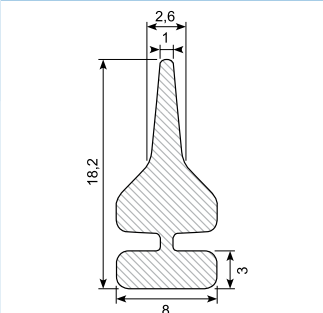

Material: EPDM black  
Hardness: SH 60  
Min. order: 1.500 m

30.11905

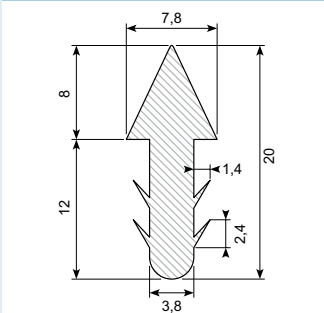

Material: Black silicone  
Hardness: SH 50

30.7249 \*

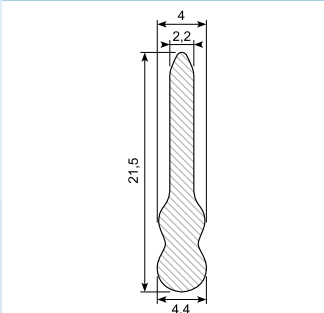

Material: CR black  
Hardness: SH 70  
Min. order: 500 m  
Conditional oil resistant

30.13049-4

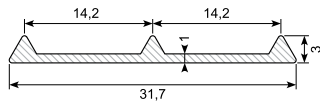

Material: Black EPDM  
Hardness: SH 60A

30.13049-2 \*

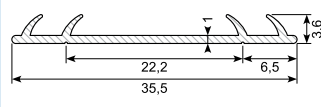

Material: EPDM  
Hardness: SH 60A  
Min. order: 5.000 m

30.13049-1 \*

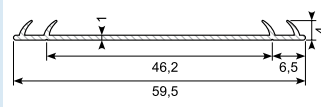

Material: EPDM  
Hardness: SH 60A  
Min. order: 4.000 m

30.13049-5 \*

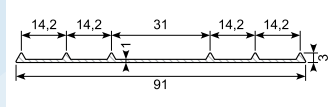

Material: Black EPDM  
Hardness: SH 60A  
Min. order: 2.000 m

30.4469

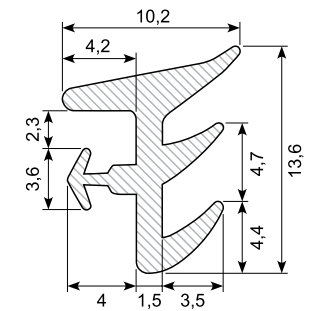

Material: EPDM  
Hardness: SH 60  
Coated with silicone

30.10485

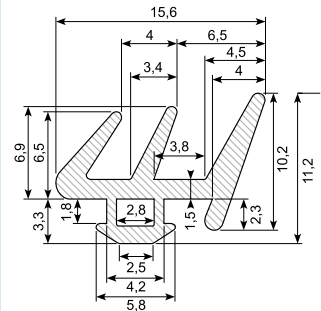

Material: EPDM  
Coated with silicone

30.9387-2 \*

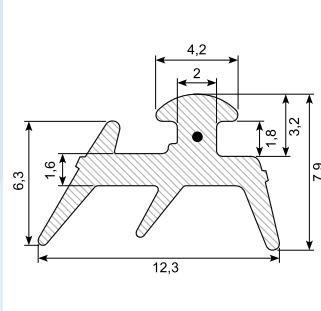

Material: EPDM  
Min. order: 5.000 m  
With internal cord

30.13796 \*

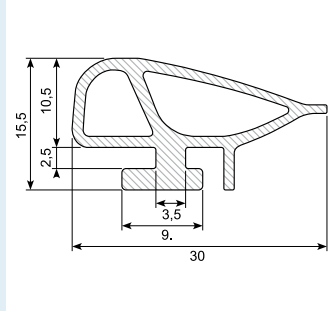

Material: Black EPDM  
Hardness: SH 75A  
Min. order: 1.000 m

30.OT1092 \*

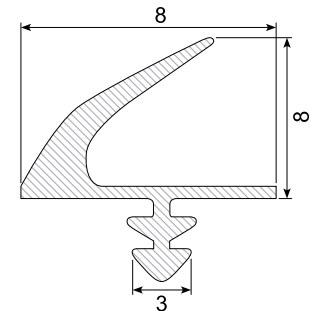

Material: Silicone **white**  
Min. order: 300 m

31.702 \*

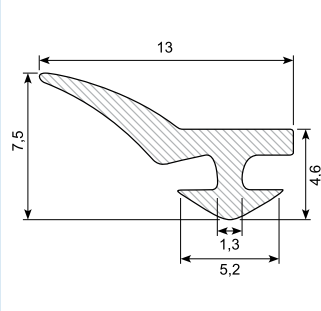

Material: EPDM black  
Hardness: SH 70  
**Conditional oil resistant**  
Min. order: 2.000 m

30.7507 \*

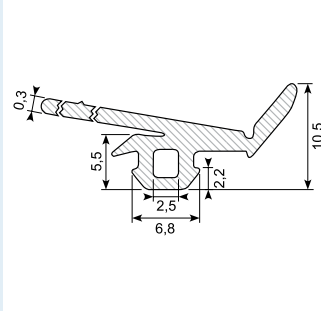

Material: EPDM black  
Hardness: SH 65  
Min. order: 1.000 m

30.10461-2

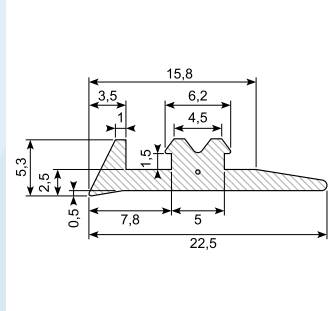

Material: EPDM with cord

30.7845 \*

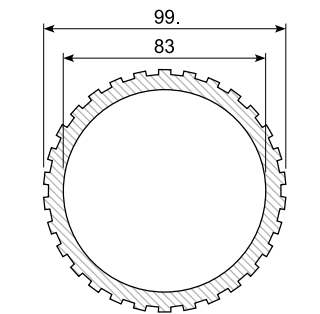

Material: SBR black  
Hardness: SH 70  
Min. order: 51 m

30.16977

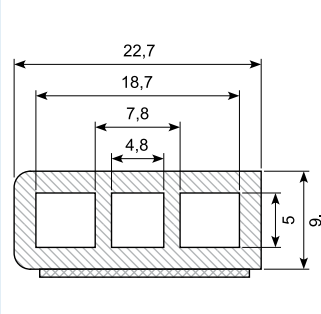

Material: **White** PVC hard  
with adhesive

30.5596 \*

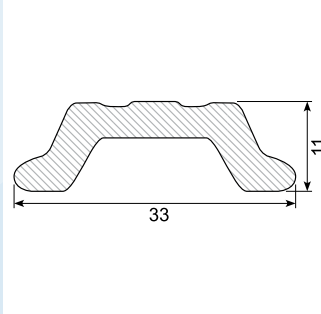

Material: EPDM black  
Hardness: SH 65  
Min. order: 500 m

52.PP106

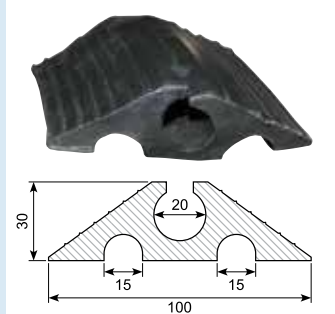

Material: NR / SBR  
Cable transmission. Roll 9 m

## 30.13503

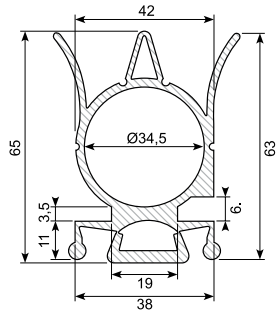

Material: Black EPDM  
Hardness: SH 60A  
For track [41.13459](#)

## 41.13459

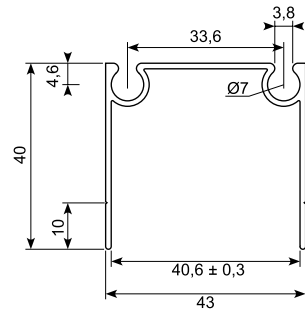

Aluprofile for gate  
Anodized surface. Length 6 m.  
Calculated weight 479 g/m.  
For profile: [30.13503](#)

## 41.13459X \*

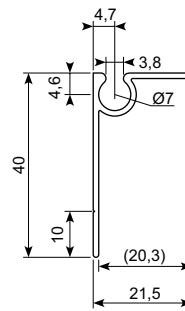

1/2 aluprofile for gate 21.5 x 40 mm  
Anodized surface. Length 6 m.  
Calculated weight: 239 g/m  
For profile: [30.13503](#)

## 30.9215

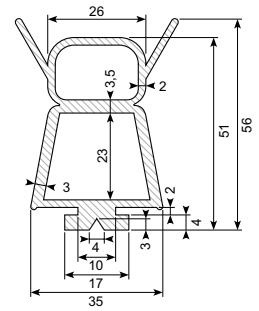

Material: EPDM  
Hardness: SH 65 - 70

## 30.9826-1

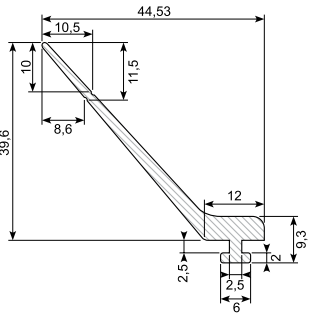

Material: EPDM  
Hardness: SH 70

## 30.9826-2

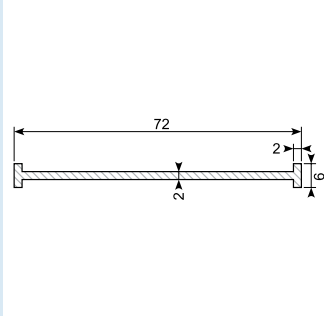

Material: EPDM  
Hardness: SH 70

## 30.10036

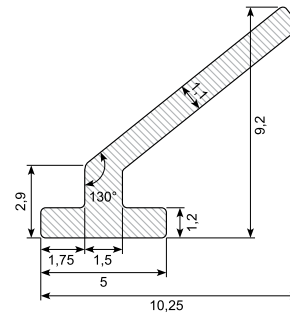

Material: EPDM  
Hardness: SH 70

## 30.9996-6

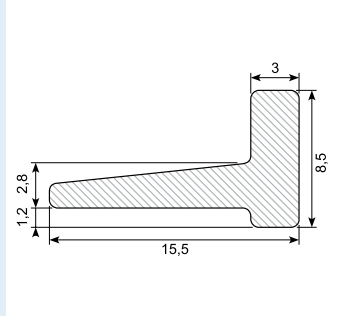

Material: EPDM  
Hardness: SH 60

## 30.13242

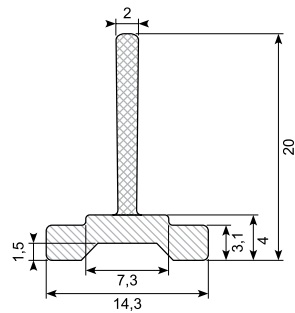

Material: Co-ex EPDM  
Hardness: SH 85 / 62  
Length: 3.000 mm  
(Rail see [41.670](#))

## 41.670

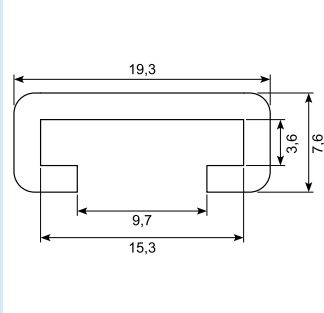

Elekeret alu.  
3 m med montagehuller.  
Ø4 hver 200 mm.  
Til profil [30.13242](#)

## 30.16239

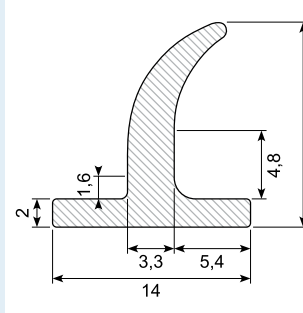

Material: EPDM  
Hardness: SH 70

## 30.9996-5

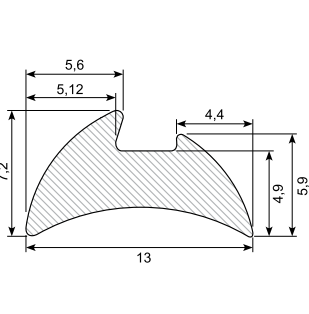

Material: EPDM  
Hardness: SH 70

## 30.9387-1

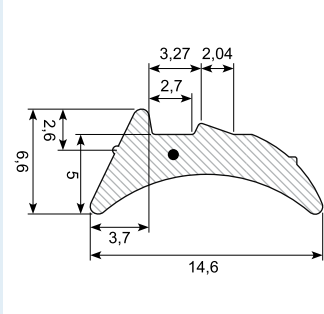

Material: EPDM  
Hardness: SH 70  
With cord

## 30.9996-4

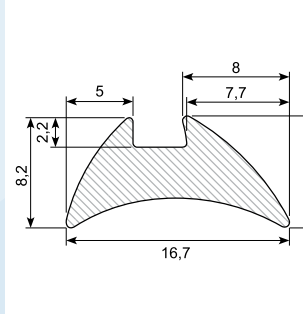

Material: EPDM  
Hardness: SH 70

30.9437-100

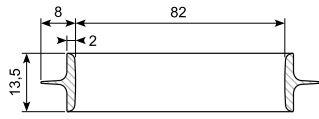

Ventilation ring  
Material: Black EPDM  
Hardness: SH 60 - 65

30.9437-125

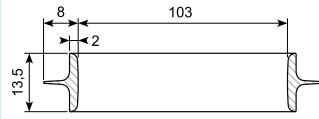

Ventilation ring  
Material: Black EPDM  
Hardness: SH 60 - 65

30.9437-160

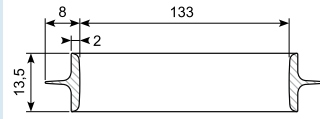

Ventilation ring  
Material: Black EPDM  
Hardness: SH 60 - 65

30.9437-200

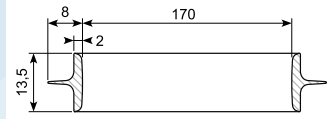

Ventilation ring  
Material: Black EPDM  
Hardness: SH 60 - 65

30.9437-250

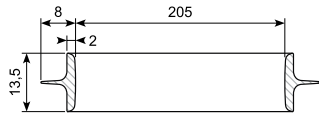

Ventilation ring  
Material: Black EPDM  
Hardness: SH 60 - 65

30.9437-315

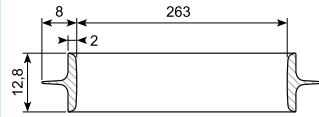

Ventilation ring  
Material: Black EPDM  
Hardness: SH 60 - 65

30.9437-400

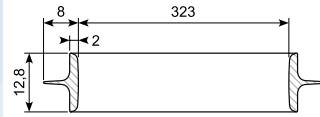

Ventilation ring  
Material: Black EPDM  
Hardness: SH 60 - 65

30.9437-500

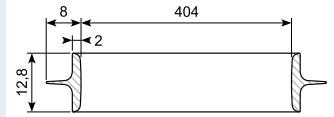

Ventilation ring  
Material: Black EPDM  
Hardness: SH 60 - 65

45.205S / 45.205SX

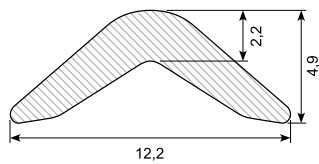

Material: Silver grey PVC

45.209BX

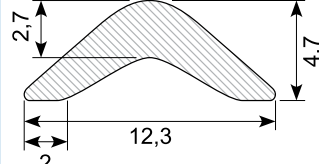

Material: Black PVC

45.210B / 45.210BX

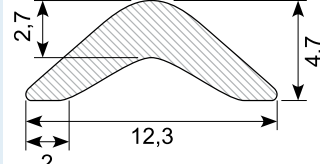

Material: White PVC

45.210C / 45.210CX

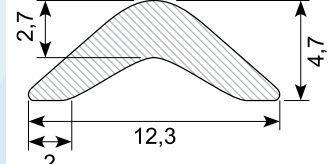

Material: Off white PVC

45.208

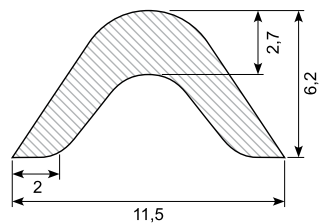

Material: Blue PVC

# Co-ekstruderede plastprofiler / Co-extruded plastic profiles

**50.083013 \***

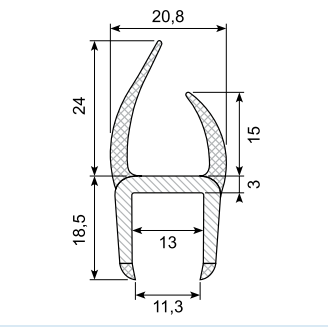

Material: PVC co-ex profile 13 mm  
Black / white  
Length: 5 m  
With 4 soft lips  
Min. order: 200 pcs

**50.083015GG / 50.083015GGX**

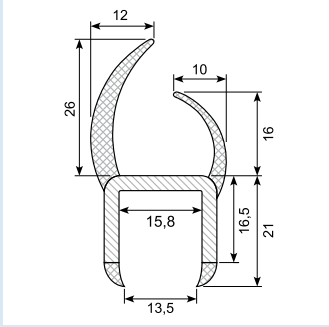

Material: PVC co-ex profile 15 mm  
Light grey / grey lips  
Length: 5 m  
With 4 soft lips  
50.083015GGX: 4 m light/light

**50.083030**

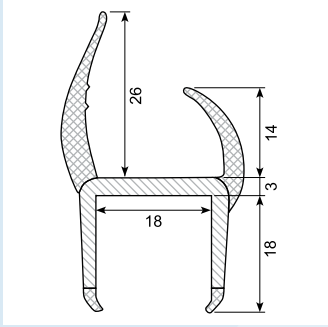

Material: PVC co-ex profile 18 mm  
Black / white  
Length: 5 m  
With 4 soft lips

**50.083032GG \***

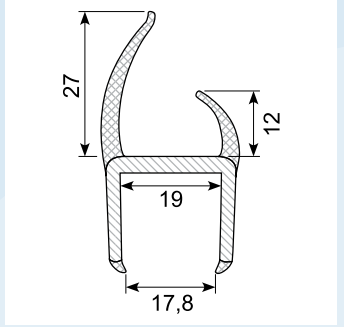

Material: PVC co-ex profile 18,4 mm. Grey / grey (other colors possible)  
Length: 6 m  
With 4 soft lips  
Min. order: 500 m

**50.083033**

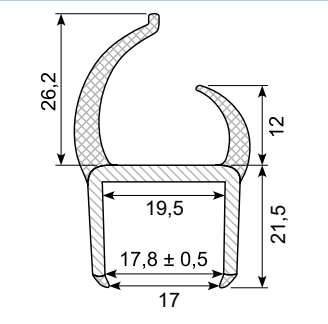

Material: PVC co-ex profile 19 mm  
Black lips / light grey  
Length: 5 m  
With 4 soft lips

**50.083040GS**

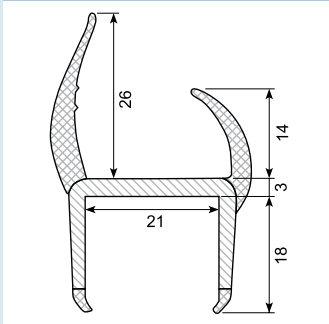

Material: PVC co-ex profile 21 mm  
Black / grey  
Length: 6 m  
With 4 soft lips

**50.083040**

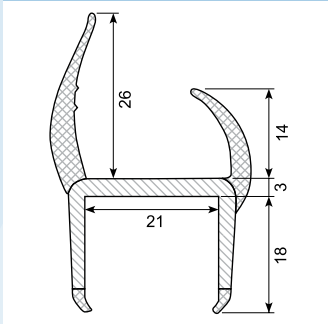

Material: PVC co-ex profile 21 mm  
Black / white  
Length: 5 m  
With 4 soft lips  
Min. order: 200 pcs.

**50.083040G**

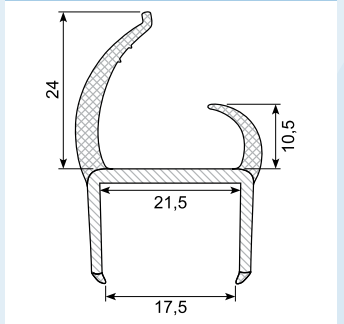

Material: PVC co-ex profile 21 mm  
Grey / grey  
Length: 5 m  
With 4 soft lips

**50.083033X**

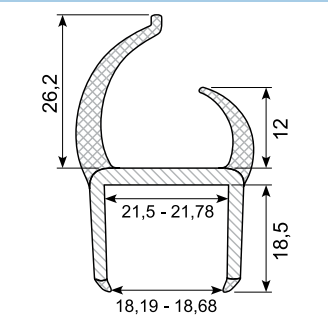

Material: PVC co-ex profile 20 mm  
Black lips / light grey  
Length: 5 m  
With 4 soft lips

**50.083040GG \***

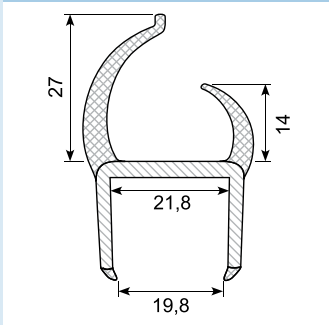

Material: PVC co-ex profile 20,8 mm. Grey / grey (other colors possible)  
Length: 6 m  
With 4 soft lips

**50.083045X \***

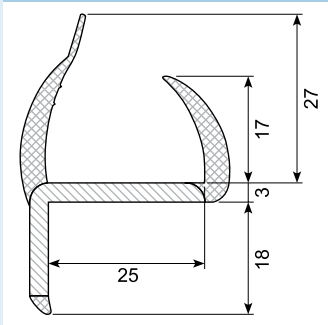

Material: PVC co-ex profile 25 mm (different colors possible)  
Length: 5 m  
With 3 soft lips  
Min. order: 250 m (China)

**54.710720 \***

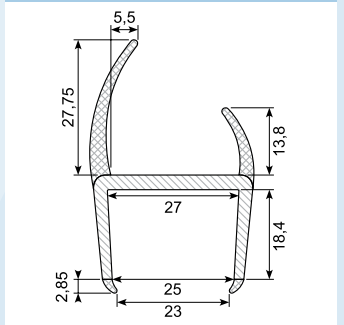

Material: PVC co-ex profile 25 mm  
Hardness: Hard/soft  
Length: 3 m  
With 4 soft lips  
Min. order: 25 pcs.

**50.083045G \***

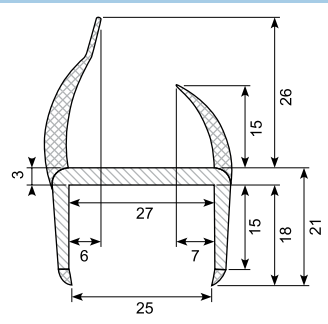

Material: PVC co-ex profile 25 mm  
Different colors possible  
Length: 6 m  
With 4 soft lips  
Min. order: 500 m

**50.083050GG \***

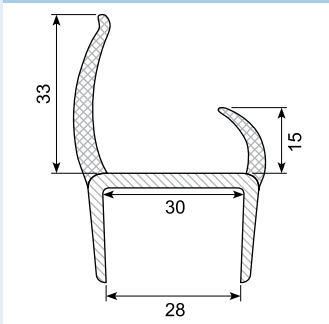

Material: PVC co-ex profile 30 mm  
Grey / grey (other colors possible)  
Length: 5 m  
With 2 soft lips  
Min. order: 500 m

**50.083050**

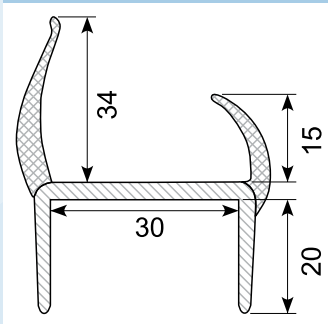

Material: PVC co-ex profile 30 mm  
Black / white  
Length: 5 m  
With 2 soft lips

**50.083050G**

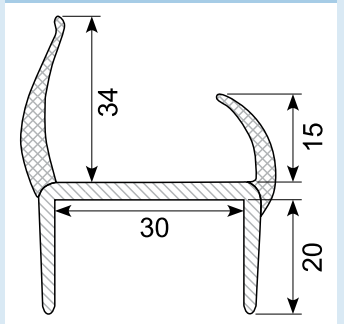

Material: PVC co-ex profile 30 mm  
Black / light grey  
Length: 5 m  
With 2 soft lips

\* Skaffevarer / Special order item



## 50.083052G \*

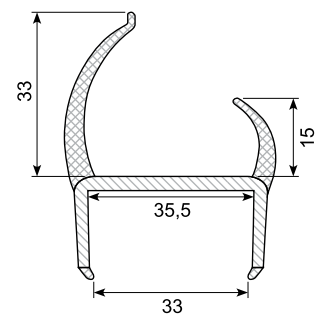

Material: PVC co-ex profile 35 mm  
Grey / grey  
(other colors possible)  
Length: 3 m  
With 4 soft lips  
Min. order: 300 m

## 50.083055G

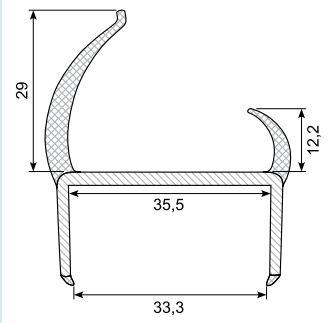

Material: PVC co-ex profile 35 mm.  
Light grey / grey lips  
Length: 5 m  
With 4 soft lips

## 50.083059 \*

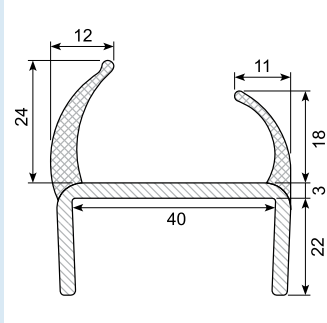

Material: PVC co-ex profile 40 mm  
White / black lips  
Length: 5 m  
With 2 soft lips  
Min. order: 250 m

## 50.083060 \*

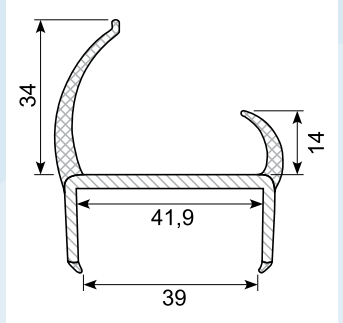

Material: PVC co-ex profile 40 mm  
White / black lips  
(other colors pos.)  
Length: 5 m  
With 4 soft lips  
Min. order: 500 m

## 50.083060G \*\*

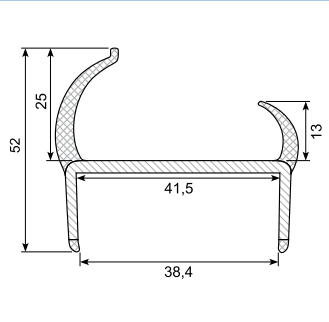

Material: PVC co-ex profile 40 mm.  
Light grey / grey lips  
Length: 5 m  
With 2 soft lips

## 50.083061 \*

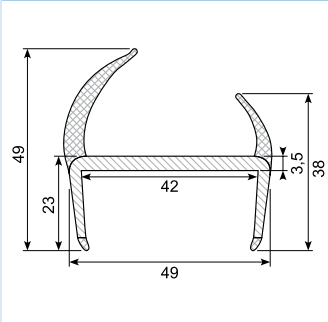

Material: PVC co-ex profile 42 mm  
White / black lips  
Length: 5 m  
With 4 soft lips  
Min. order: 250 m (China)

## 50.083065 \*

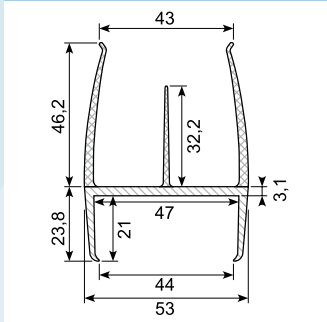

Material: PVC co-ex profile 45 mm  
Grey / grey  
(other colors possible)  
Length: 5 m  
With 3 soft lips  
Min. order: 250 m

## 50.083065G \*

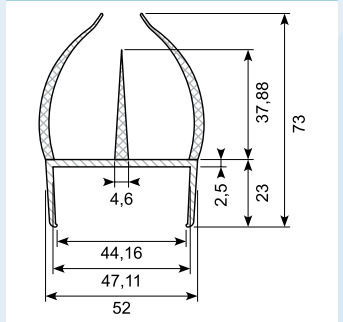

Material: Co-ex profile  
Length: 5 m

## 50.083070G

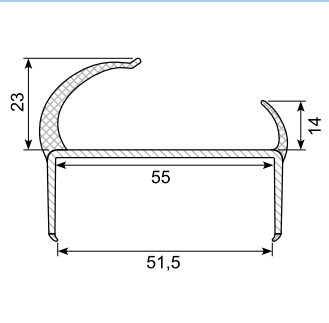

Material: PVC co-ex profile 55 mm  
Light grey / grey lips  
Length: 5 m  
With 4 soft lips

## 50.083070B \*

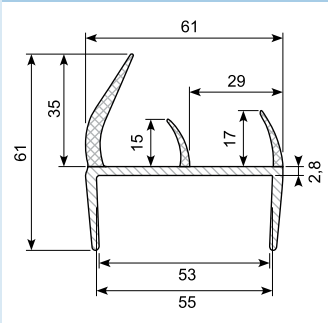

Material: PVC co-ex profile 55 mm.  
White / black lips  
Length: 5 m  
Min. order: 500 m  
With 4 soft lips

## 54.710770 \*

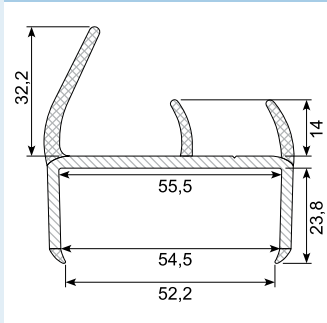

Material: Grey PVC co-ex profile 30 mm  
Length: 3 m  
Min. order: 50 m  
With 4 soft lips

## 50.083081 \*

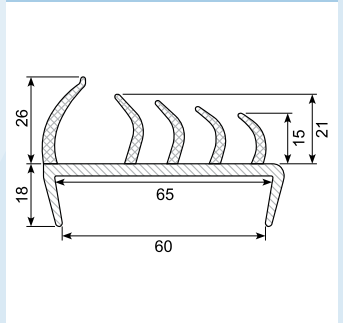

Material: Black PVC co-ex profile 65 mm  
With 5 soft lips  
Min. order: 250 m

## 50.083080GG \*

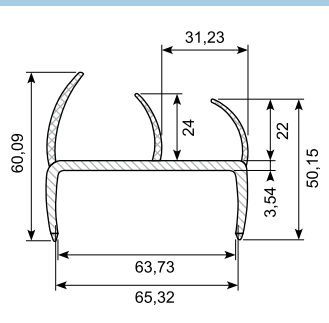

Material: PVC co-ex profile 65 mm  
Light grey / light grey lips  
Length: 5 m  
With 3 soft lips  
Min. order: 250 m (China)

## 50.083080G

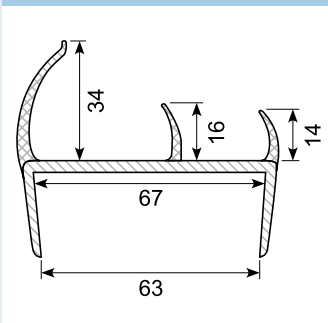

Material: PVC co-ex profile 65 mm.  
Grey / grey lips  
Length: 5 m  
With 2 soft lips

## 50.083088 \*

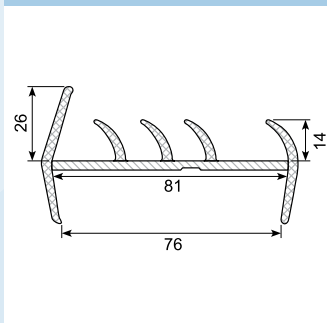

Material: PVC co-ex profile 81 mm.  
Black  
With 5 soft lips  
Min. order: 250 m

## 50.083089 \*

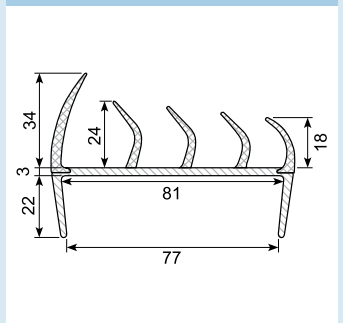

Material: PVC co-ex profile 81 mm.  
Black  
With 5 soft lips  
Min. order: 250 m

## Co-ekstruderede plastprofiler / Co-extruded plastic profiles

50.083090

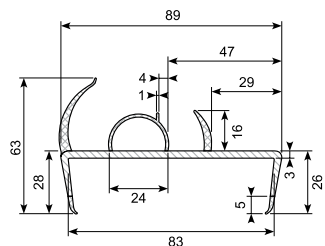

Material: PVC co-ex profile 83 mm. Light grey / light grey  
Length: 5 m  
With 4 soft lips

50.083095B \*

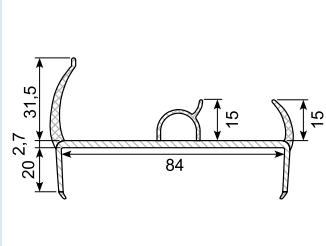

Material: PVC co-ex profile 84 mm. White / black lips.  
Length: 5 m  
Min. order: 500 m  
With 4 soft lips

50.083095 / 50.083095G \*

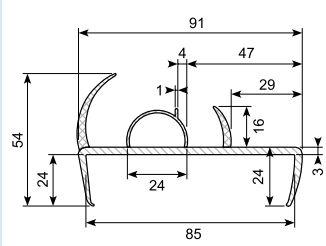

Material: PVC co-ex profile 85 mm. White / black lips.  
Length: 5 m  
With 4 soft lips  
50.083095G: Min order: 250 m.

54.710780 \*

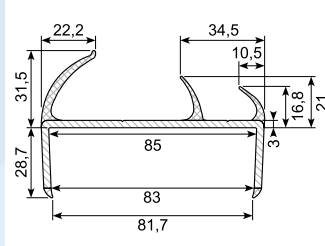

Material: PVC co-ex profile 85 mm. Black / grey  
Hardness: Hard / soft  
Length: 3 m  
With 4 soft lips  
Min. order: 50 pcs.

50.083000GG

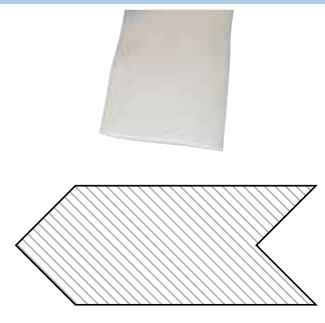

Grå hjørnebånd  
Grey connection part. Soft PVC.  
In running meters

50.083000SS

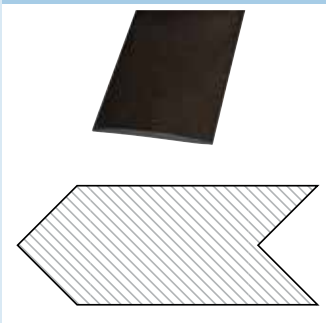

Sort hjørnebånd  
Black connection part. Soft PVC.  
In running meters

31.018S \*

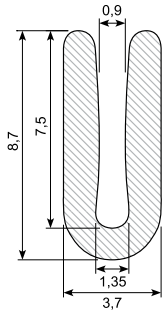

Material: Black EPDM  
 Hardness: SH 65  
 Min. order: 4.100 m

31.018X

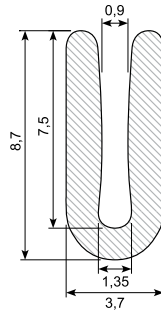

Material: PVC black  
 Hardness: SH 65

34.018 / 34.018X

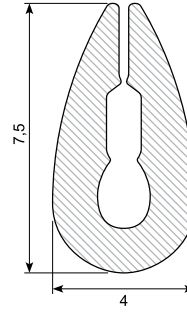

Material: Light grey PVC  
 Hardness: Soft

34.14334X

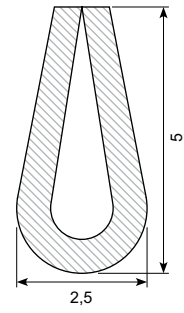

Material: Black PVC  
 Plade: 1,5 - 2 mm

31.060S

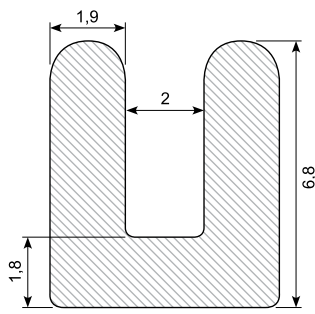

Material: EPDM black  
 Hardness: SH 65

31.041S



Material: EPDM black  
 Hardness: SH 65

31.042S

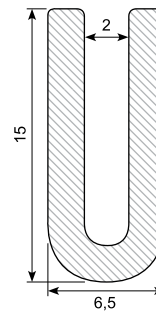

Material: EPDM black  
 Hardness: SH 65

30.OT3394 \*

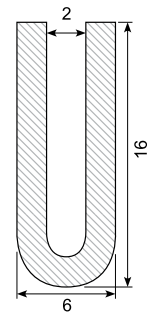

Material: Silicone black  
 Min. order: 100 m

31.047 \*



Material: EPDM black  
 Hardness: SH 65  
 Min. order: 1.000 m

31.063

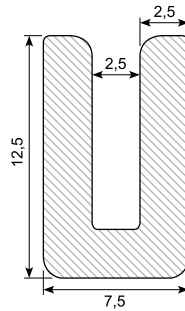

Material: EPDM black  
 Hardness: SH 65

30.9548

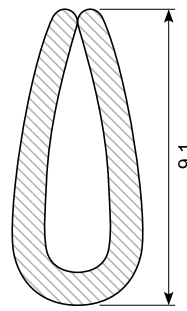

Material: Light grey hard PVC  
 Length: 3,9 m

31.025S

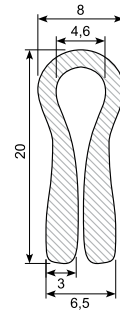

Material: EPDM black  
 Hardness: SH 65

31.021S

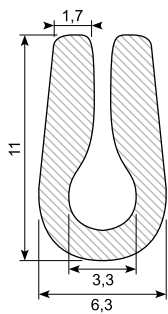

Material: EPDM black  
 Hardness: SH 65

31.022S

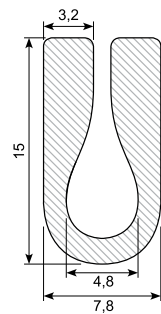

Material: EPDM black  
 Hardness: SH 65

34.031 / 34.031X

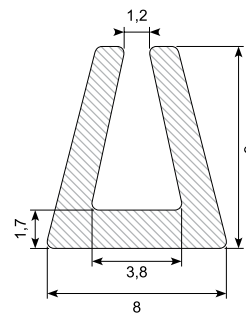

Material: PVC transparent  
 Hardness: Soft

30.13086

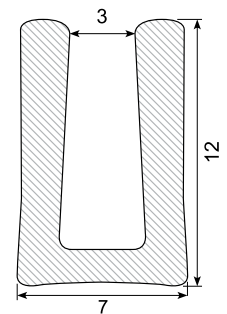

Material: EPDM black  
 Hardness: SH 80

**31.043S**

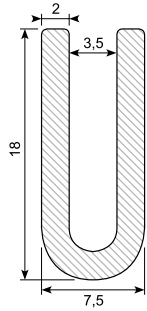

Material: EPDM black  
Hardness: SH 65

**31.064**

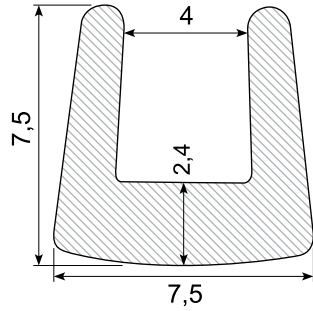

Material: EPDM black  
Hardness: Hard

**31.065S**

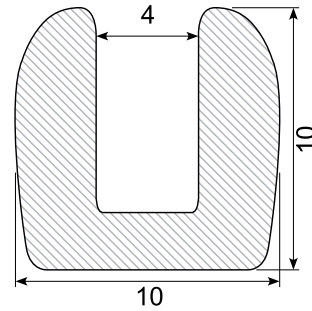

Material: EPDM black  
Hardness: SH 65

**31.061S**

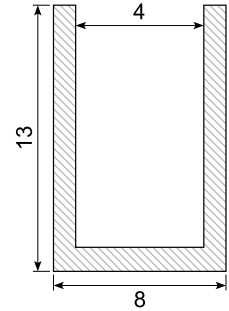

Material: EPDM black  
Hardness: SH 65

**30.6622N**

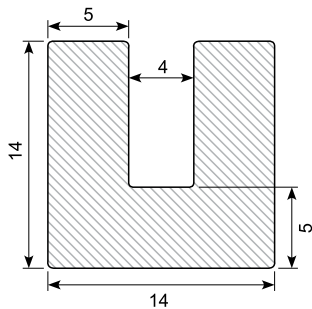

Material: NBR black  
Hardness: SH 65  
Oil resistant

**30.6622 \***

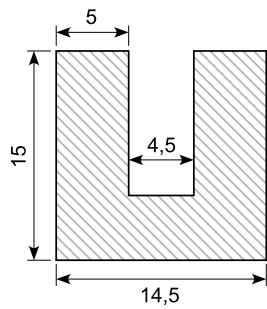

Material: EPDM black  
Hardness: SH 65  
Min. order: 500 m

**31.216ST**

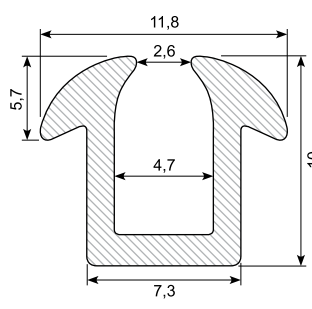

Material: EPDM black  
Hardness: SH 65

**31.216GS**

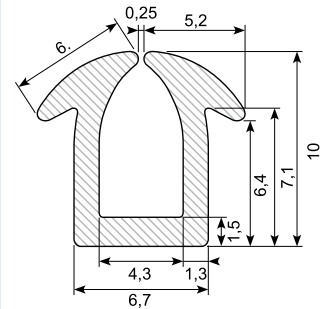

Material: Silicone light grey  
Ral 7040  
Hardness: SH 70

**30.11459 \***

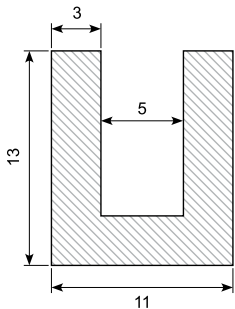

Material: Silicone transparent  
Hardness: SH 45  
Min. order: 250 m

**34.035**

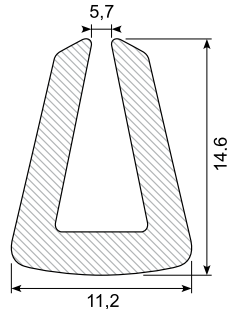

Material: PVC transparent  
Hardness: Hard

**31.066**

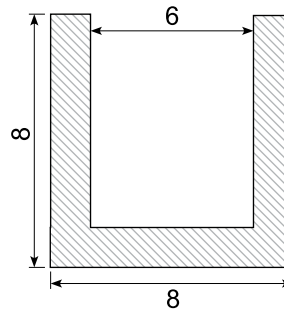

Material: Silicone black  
Hardness: SH 70

**30.6724**

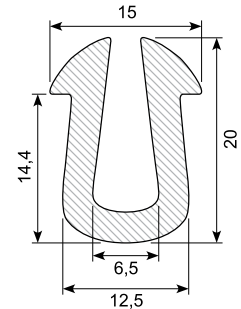

Material: EPDM black  
Hardness: SH 65

**30.14507-1 \***

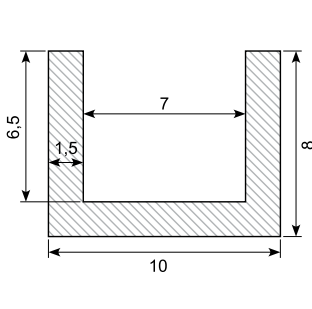

Material: EPDM black  
Min. order: 3.000 m

**30.14507-2 \***

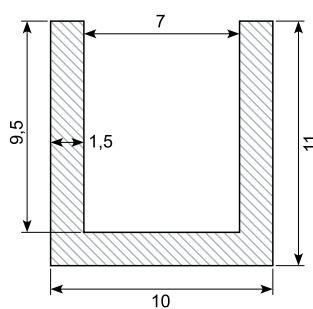

Material: EPDM black  
Min. order: 3.000 m

**31.068S**

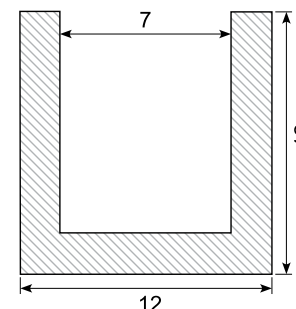

Material: EPDM black  
Hardness: SH 65

**30.1386**

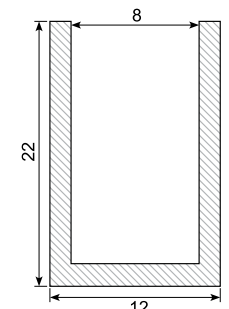

Material: EPDM black  
Hardness: SH 65

30.OT3440 \*

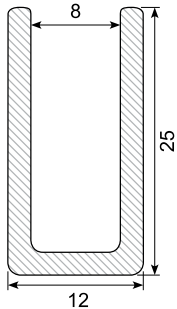

Material: Silicone black  
 Hardness: SH 60  
 Min. order: 100 m

30.12896

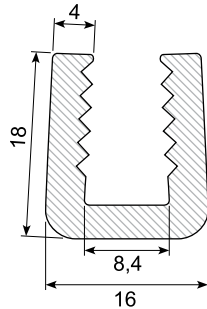

Material: EPDM black  
 Hardness: SH 65

31.074S \*

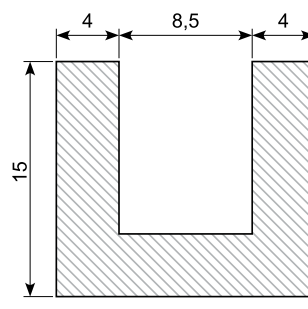

Material: EPDM black  
 Min. order: 1.000 m

30.7987

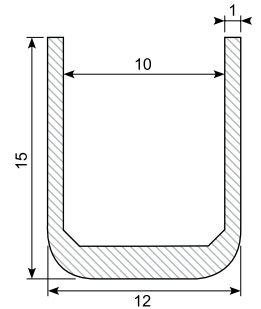

Material: EPDM black  
 Hardness: SH 65

30.OT0136 \*

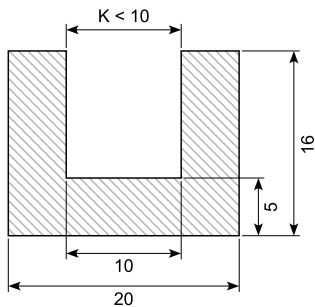

Material: White silicone  
 Min. order: 100 m

31.070S

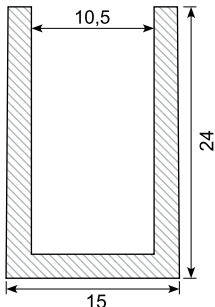

Material: EPDM black  
 Hardness: SH 50

31.071S

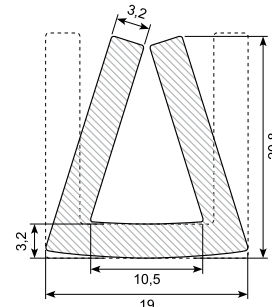

Material: EPDM black  
 Hardness: SH 65

30.2449

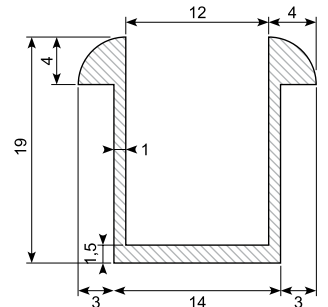

Material: Black PVC  
 Length: 1.415 mm

30.2455

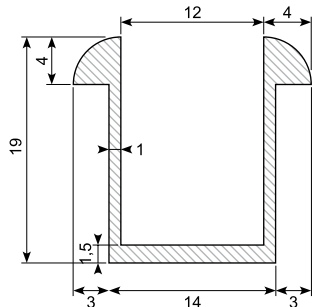

Material: Black PVC  
 Length: 3.111 mm

30.11774

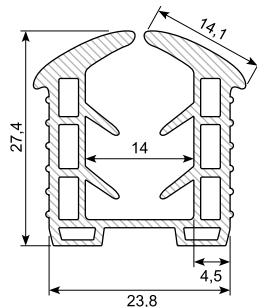

Material: EPDM  
 Hardness: SH 65

30.7508 \*

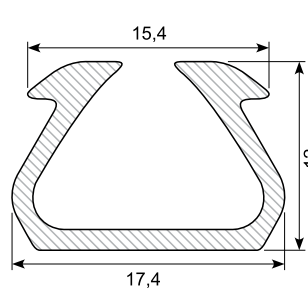

Material: EPDM black  
 Hardness: SH 65  
 Min. order: 400 m

30.9519

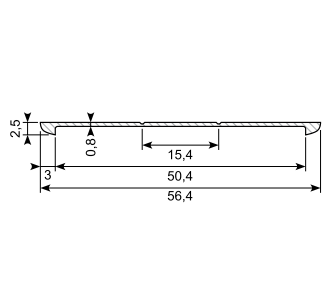

Material: Black soft PVC

30.12932-1 \*

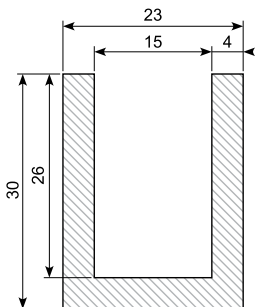

Material: Black EPDM  
 Hardness: SH 60A  
 Min. order: 500 m

30.13535 \*

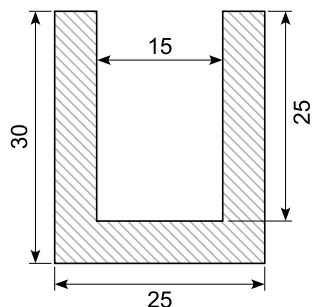

Material: EPDM black  
 Hardness: SH 60  
 Min. order: 420 m

30.7509

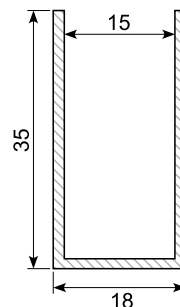

Material: EPDM black  
 Hardness: SH 65

30.10777-1 \*

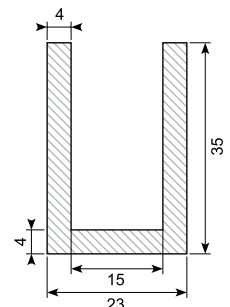

Material: TPE black  
 Hardness: SH 60  
 Min. order: 100 m

**30.21101205**

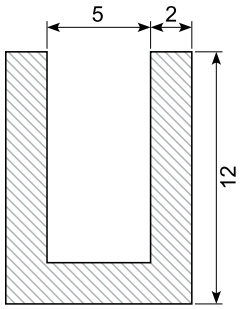

Material: EPDM  
Hardness: SH 70

**30.14507-3 \***

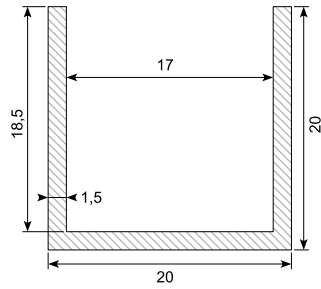

Material: EPDM  
Min. order: 2.000 m

**31.050**

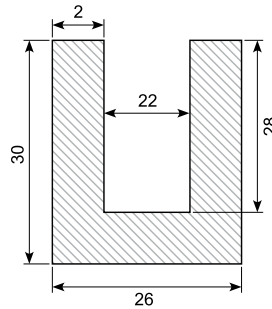

Material: EPDM black  
Hardness: SH 65

**30.14356**

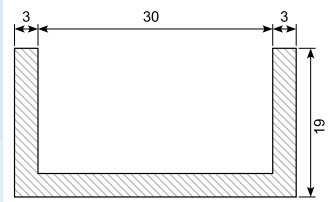

Material: Black TPE  
Hardness: SH 60

**31.048 \***

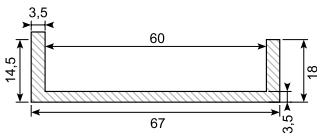

Material: EPDM black  
Hardness: SH 65  
Min. order: 250 m

**30.11911 \***

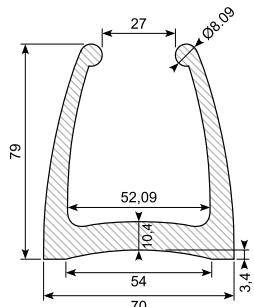

Material: EPDM  
Hardness: SH 65  
Min. order: 120 m

**30.2984-5**

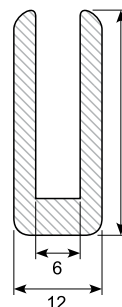

U-profile  
Material: EPDM  
Hardness: SH 70

**34.117/6**

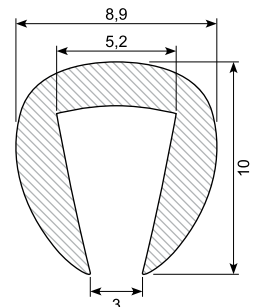

Material: Metal grey plastic

**30.2984-6**

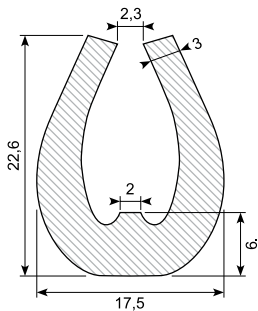

U-profile  
Material: EPDM  
Hardness: SH 80  
Roll of 50 m

**30.2984-1**

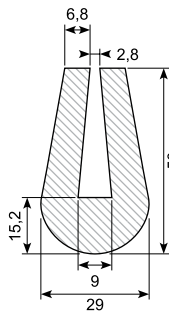

U-profile  
Material: EPDM  
Hardness: SH 70  
Roll of 25 m

**30.2984-2**

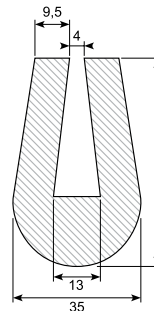

U-profile  
Material: EPDM  
Hardness: SH 65  
Roll of 25 m

**30.2984-3**

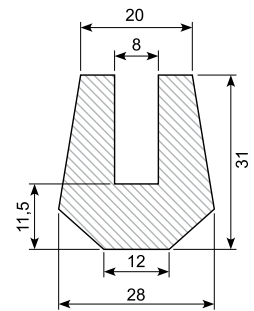

U-profile  
Material: EPDM  
Hardness: SH 70  
Roll of 25 m

**30.7519NBR \***

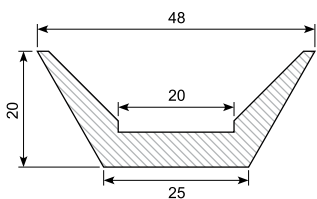

Material: NBR grey  
Hardness: SH 65  
Length: 3 m  
Min. order: 500 m

Oil resistant  
\* Skaffevare / Special order item

**30.7519 \***

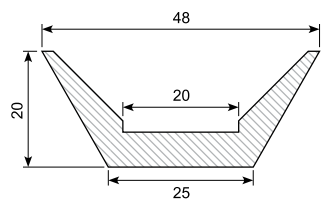

Material: EPDM black  
Hardness: SH 65  
Length: 50 m coils  
Min. order: 50 m

**30.14227 \***

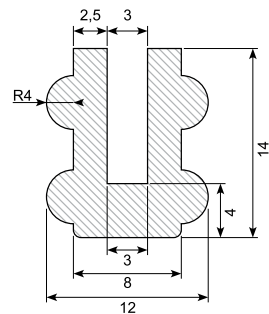

Material: Transperent silicone  
Min. order: 100 m

31.037SI

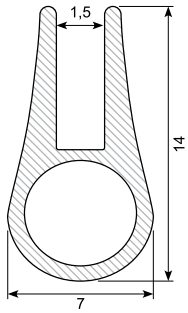

Material: Black silicone

31.035S

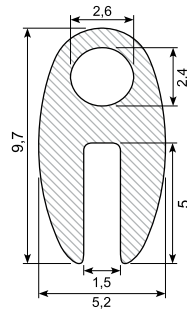

Material: EPDM black  
Hardness: SH 65

31.036SI \*

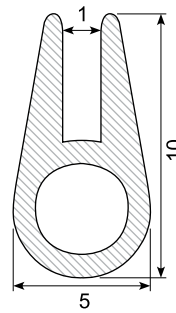

Material: Silicone black  
Min. order: 200 m

31.036SI-LTC \*

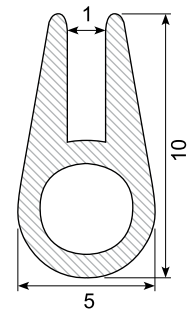

Material: Silicone black  
UL94 approved  
Min. order: 1.000 m

30.9884X \*

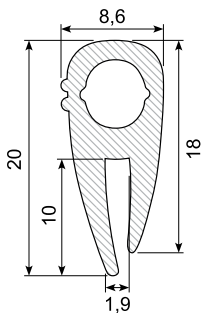

Material: EPDM  
Min. order: 3.000 m

31.037 \*

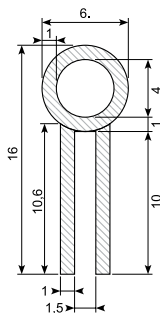

Material: EPDM  
Hardness: SH 56 - 60A  
Min. order: 2.000 m

30.9885

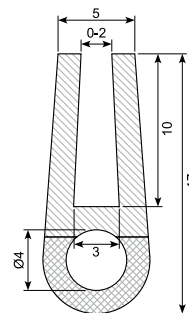

Material: EPDM  
Hardness: SH 60

31.038SI

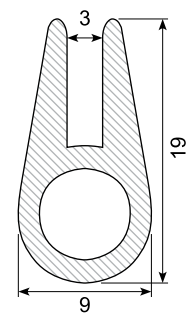

Material: Silicone black  
Hardness: SH 60

# P-profiler / P-profiles

30.136

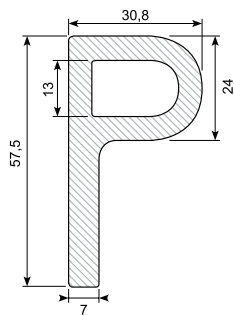

Material: EPDM black  
Hardness: SH 65

30.136NBR \*\*

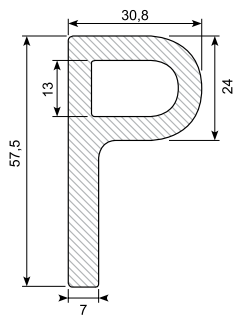

Material: NBR black  
Hardness: SH 65  
Oil resistant

30.136/45

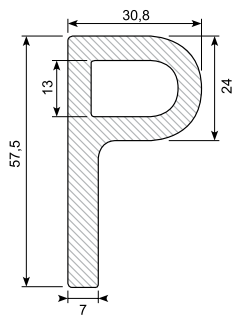

Material: EPDM black  
Hardness: SH 45 soft

30.OT1057 \*

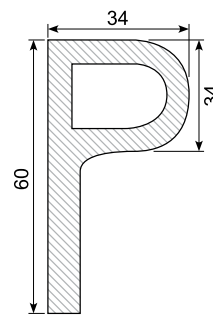

Material: Silicone white  
Maks. 270°  
Min. order: 50 m

30.182 \*

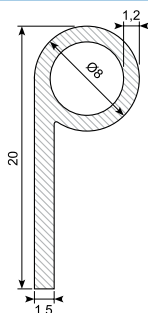

Material: Grey silicone  
RAL 7040  
Min. order: 100 m

30.22381

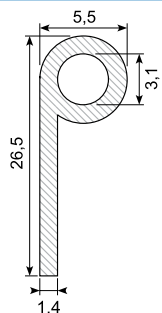

Material: CR black  
Hardness: SH 70  
Conditional oil resistant

30.148S \*

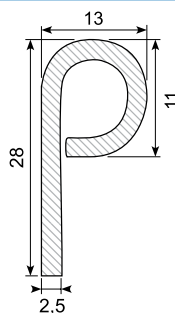

Material: EPDM black  
Hardness: SH 65  
Min. order: 450 m

30.7408X

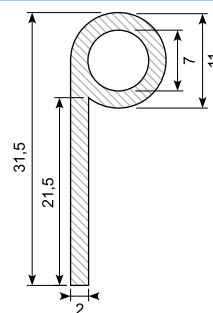

Material: Black EPDM

30.OT2036

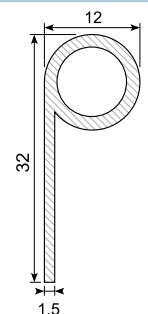

Material: Silicone black  
Maks. 270°

30.140

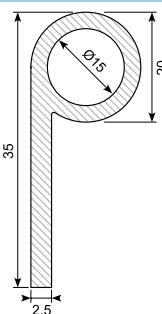

Material: EPDM

30.138S

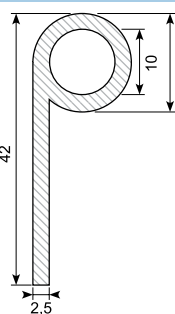

Material: EPDM black  
Hardness: SH 65

30.138NBR \*

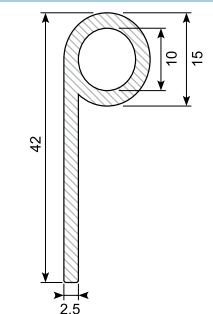

Material: NBR  
Oil resistant  
Min. order: 500 m

30.OT101 \*

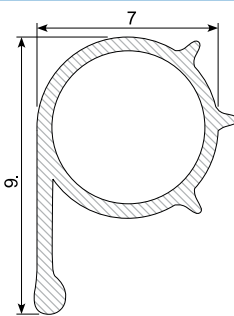

Material: Silicone brown  
Min. order: 100 m

52.269 / 52.269X

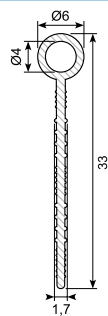

Material: PVC black  
Hardness: Medium

30.174S

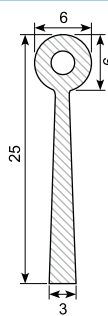

Material: EPDM black  
Hardness: SH 65

30.176 \*

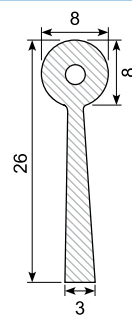

Material: EPDM black  
Hardness: SH 65  
Min. order: 1.000 m



30.180

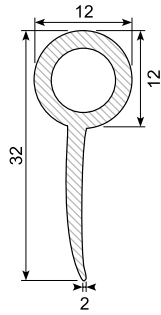

Material: EPDM black  
Hardness: SH 65

30.8538

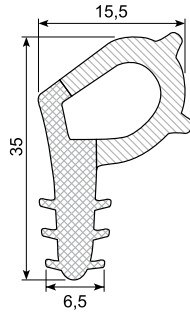

Material: EPDM co-ex  
Hardness: SH 65 / density 0,70

30.8538B

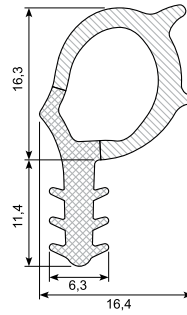

Material: EPDM co-ex  
Hardness: SH 65 / density 0,5  
Min. order: 2.000 m

30.OT3271 \*

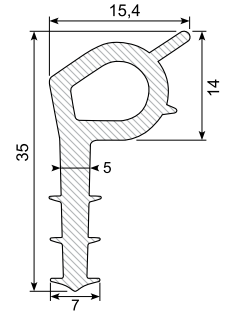

Material: Silicone light grey  
Min. order: 500 m

30.6487 \*

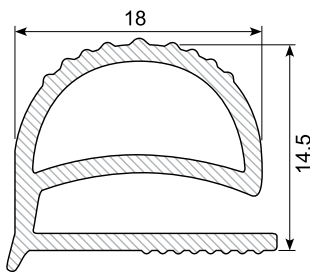

Material: PVC grey  
Length: 3 m  
Min. order: 1.000 m

30.SM251 \*

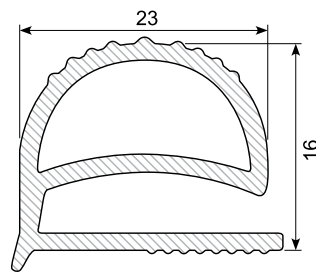

Material: TPE / EPDM grey  
Hardness: SH 65  
Length: 25 M  
Min. order: 200 m

30.OT1081

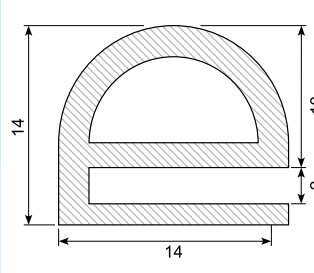

Material: Silicone white

30.OT3334

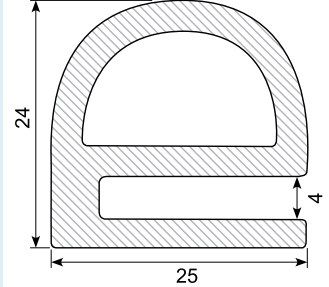

Material: Silicone white

31.OT2179 \*

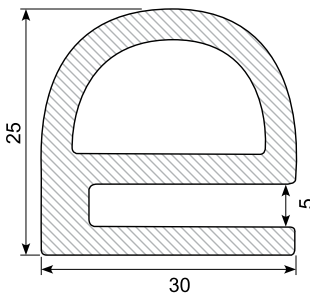

Material: Silicone white  
Min. order: 100 m

## 32.016S

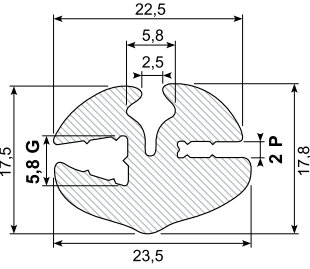

Material: EPDM black  
Hardness: SH 65  
Min. radius: 90 mm

## 32.924 \*\*

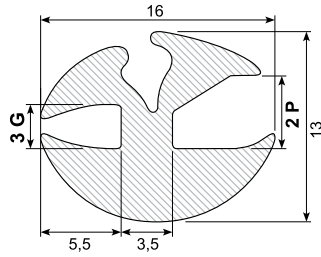

Material: EPDM black  
Hardness: SH 60  
Min. radius: 30 mm  
Incl. wedge

## 32.2024CR \*

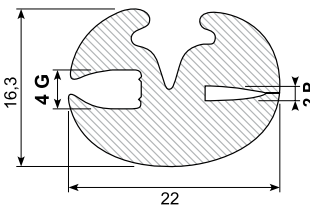

Material: CR black  
Hardness: SH 65  
Min. radius: 80 mm  
Min. order: 200 m  
Oil resistant

## 32.1024S

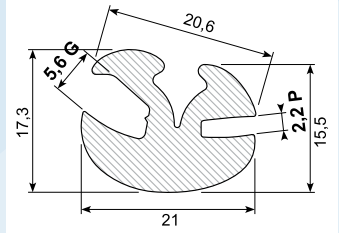

Material: EPDM black  
Hardness: SH 65  
Min. radius: 80 mm

## 32.1025S

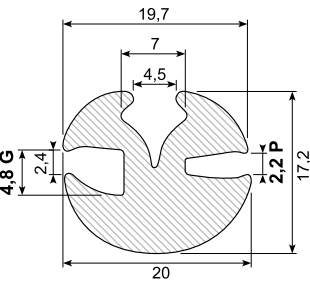

Material: EPDM black  
Hardness: SH 65  
Min. radius: 80 mm

## 32.2024M

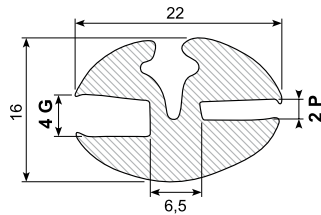

Material: EPDM black  
Hardness: SH 65  
Min. radius: 80 mm

## 32.1025SK

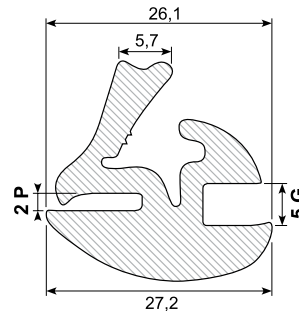

Material: EPDM black  
Hardness: SH 65  
Min. radius: 80 mm  
Incl. wedge

## 32.034S

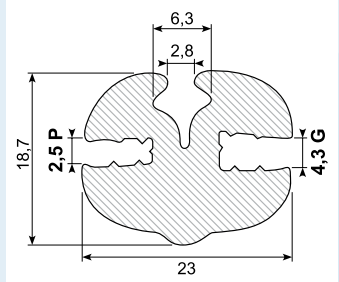

Material: EPDM black  
Hardness: SH 65  
Min. radius: 90 mm

## 32.036S

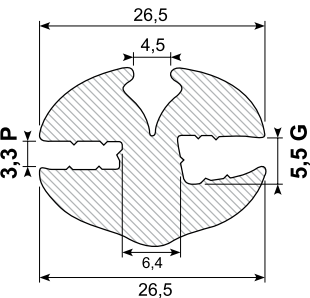

Material: EPDM black  
Hardness: SH 65  
Min. radius: 75 mm

## 32.1045SK \*

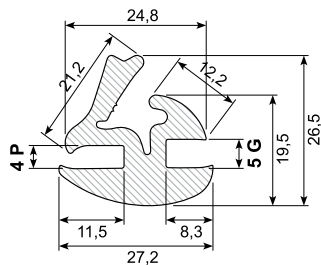

Material: EPDM black  
Hardness: SH 65  
Min. radius: 80 mm  
Incl. wedge  
Min. order: 100 m

## 32.044S

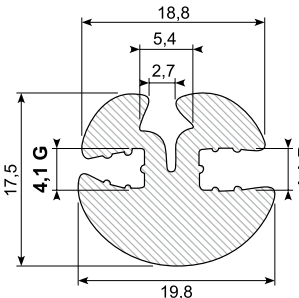

Material: EPDM black  
Hardness: SH 65  
Min. radius: 75 mm

## 32.046S

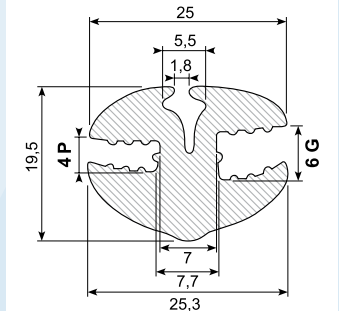

Material: EPDM black  
Hardness: SH 65  
Min. radius: 90 mm

## 32.2045M

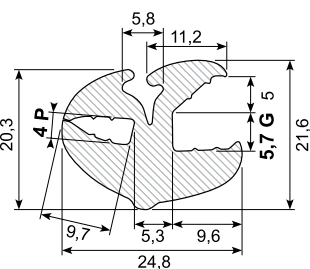

Material: EPDM black  
Hardness: SH 65  
Min. radius: 90 mm

## 30.8439

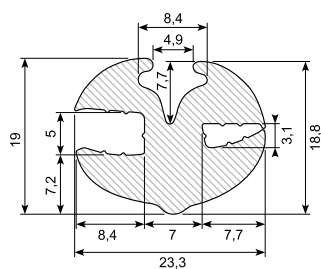

Material: EPDM  
Hardness: SH 65

## 32.036X

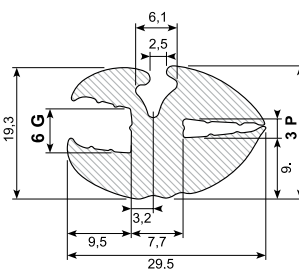

Material: EPDM  
Hardness: SH 65

## 32.047

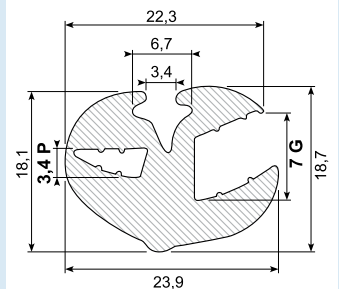

Material: EPDM black  
Hardness: SH 65  
Min. radius: 90 mm

32.1045S

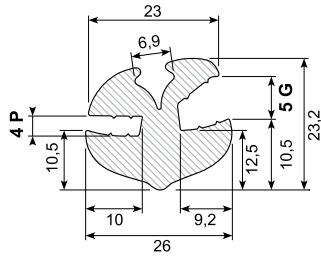

Material: EPDM black  
Hardness: SH 65  
Min. radius: 90 mm

32.057 \*

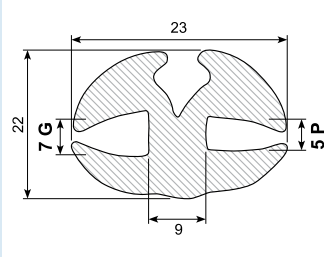

Material: EPDM black  
Hardness: SH 65  
Min. radius: 100 mm  
Min. 300 m

32.255S

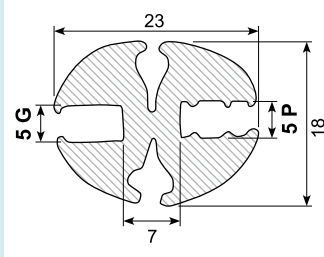

Material: EPDM black  
Hardness: SH 65  
Min. radius: 100 mm

32.064S

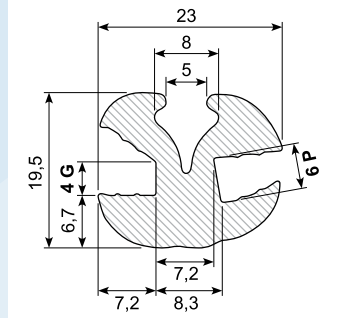

Material: EPDM black  
Hardness: SH 70

32.066

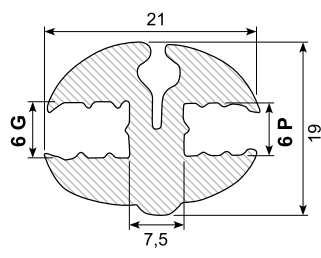

Material: EPDM black  
Hardness: SH 65  
Min. radius: 80 mm

32.075

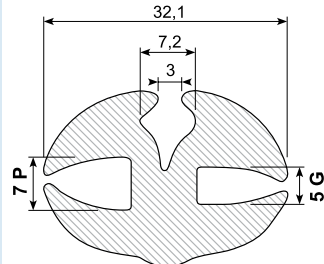

Material: EPDM black  
Hardness: SH 65  
Min. radius: 100 mm

32.095S

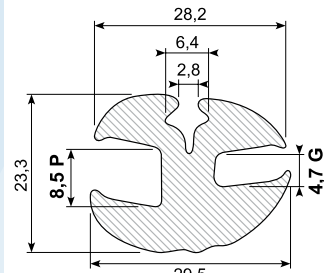

Material: EPDM black  
Hardness: SH 65  
Min. radius: 115 mm

32.512

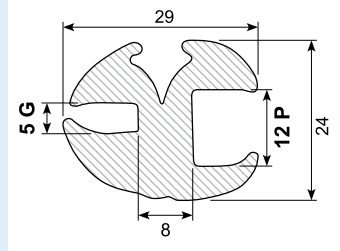

Material: EPDM black  
Hardness: SH 65  
Min. radius: 115 mm

32.165

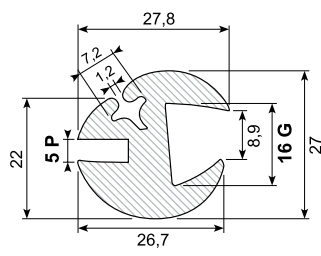

Material: EPDM black  
Hardness: SH 65  
Min. radius: 120 mm

32.514S

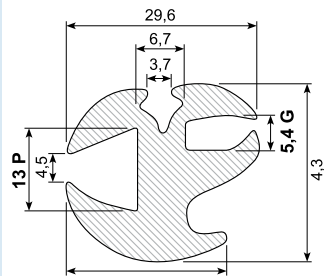

Material: EPDM black  
Hardness: SH 65  
Min. radius: 110 mm

32.516S

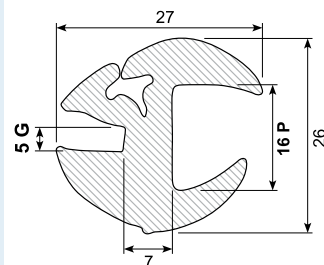

Material: EPDM black  
Hardness: SH 65  
Min. radius: 120 mm

32.523S

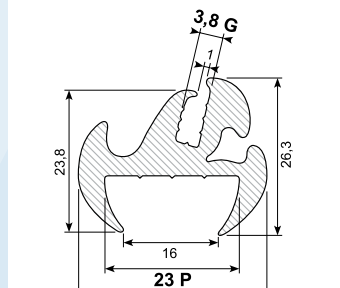

Material: EPDM black  
Hardness: SH 65  
Min. radius: 110 mm

32.527

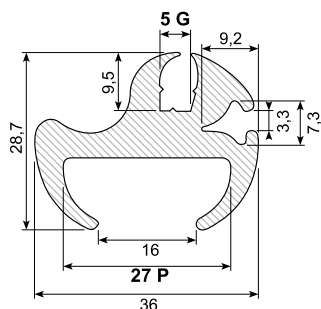

Material: EPDM black  
Hardness: SH 65  
Min. radius: 120 mm

32.1037S

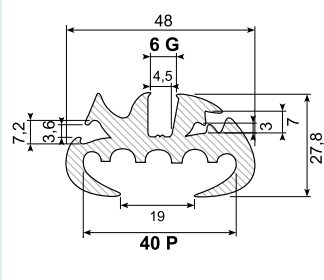

Material: EPDM black  
Hardness: SH 65  
Min. radius: 120 mm

32.1640

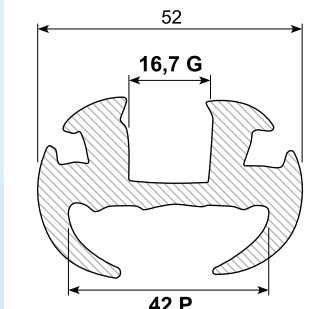

Material: EPDM black  
Hardness: SH 65  
Min. radius: 120 mm

32.754S

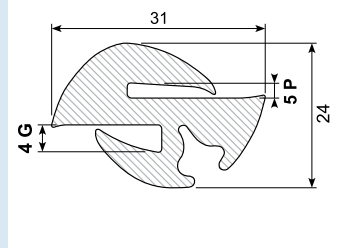

Material: EPDM black  
Hardness: SH 65  
Min. radius: 100 mm  
Safety

**32.866 \***

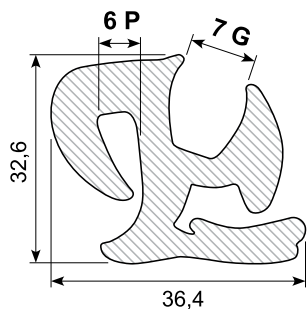

Material: EPDM black  
 Hardness: SH 65  
 Min. radius: 120 mm  
 Safety  
 Min. order: 250 m

**32.795S**

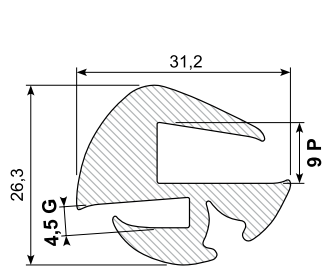

Material: EPDM black  
 Hardness: SH 65  
 Min. radius: 100 mm  
 Safety

**32.7125 \***

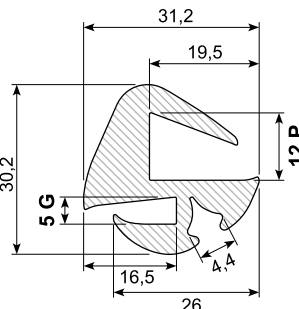

Material: EPDM black  
 Hardness: SH 65  
 Min. radius: 120 mm  
 Safety  
 Min. order: 250 m

**32.7195S**

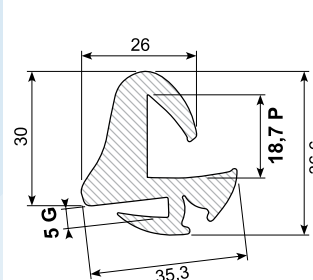

Material: EPDM black  
 Hardness: SH 65  
 Min. radius: 120 mm  
 Safety

**31.365**

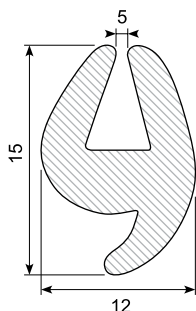

Material: EPDM black  
 Hardness: SH 65

**31.116S**

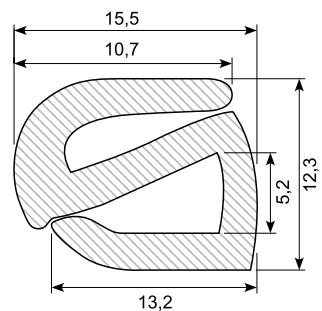

Material: EPDM black  
 Hardness: SH 65

**31.112S**

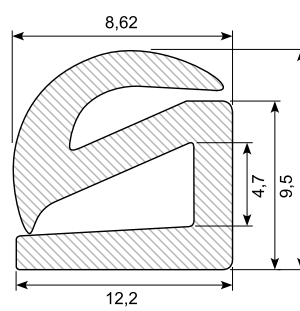

Material: EPDM black  
 Hardness: SH 65

**31.145S**

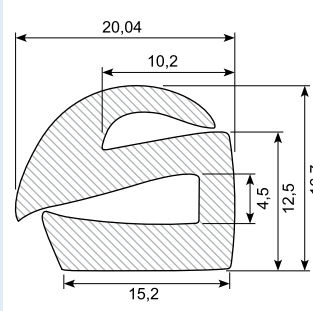

Material: EPDM black  
 Hardness: SH 65

**31.148**

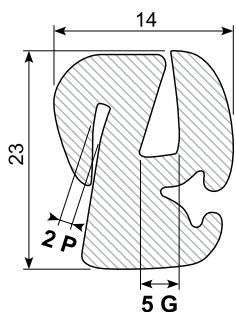

Material: EPDM black  
 Hardness: SH 65

**31.155**

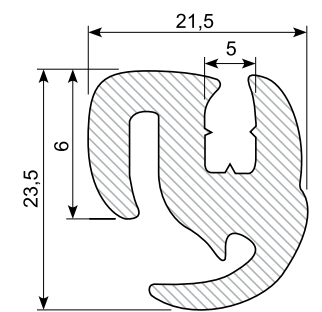

Material: EPDM black  
 Hardness: SH 65

**31.6701**

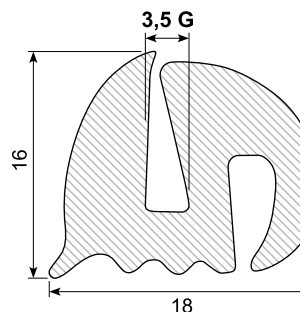

Material: EPDM black  
 Hardness: SH 65

**31.6703 \***

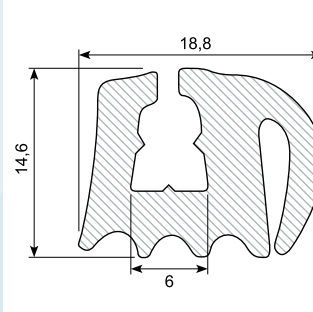

Material: EPDM black  
 Hardness: SH 65  
 Min. order: 1.000 m

**31.6702 \***

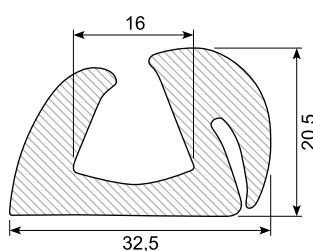

Material: EPDM black  
 Hardness: SH 65  
 Min. order: 500 m

32.309X

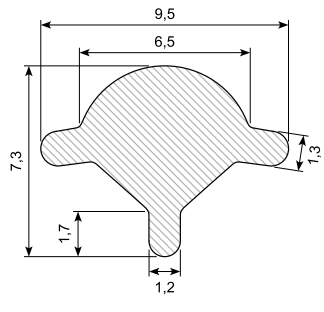

Material: PVC black

32.301 / 32.301X

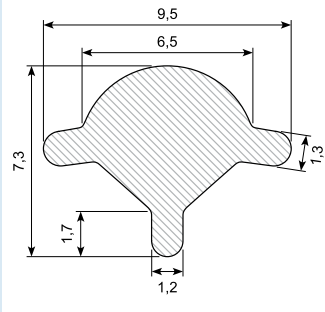

Material: PVC silver

32.300X

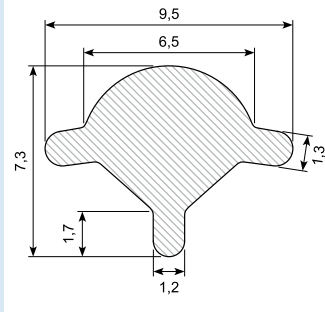

Material: PVC white

32.1301

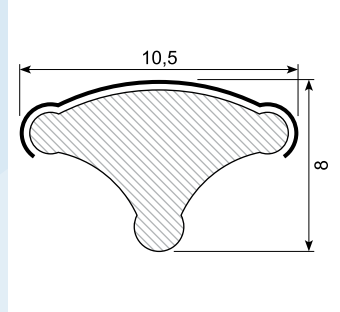

Material: PVC chrome

32.409 / 32.409X

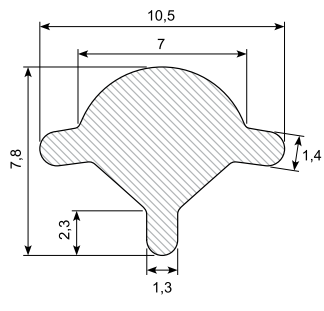

Material: PVC black

32.009S

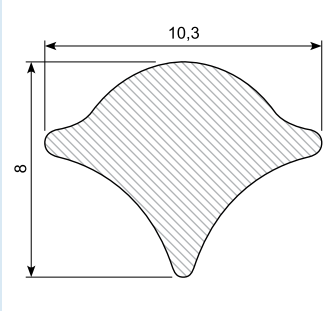

Material: EPDM black  
Hardness: SH 65

32.010

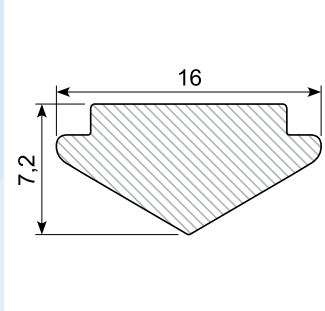

Material: EPDM black  
Hardness: SH 65

32.924K

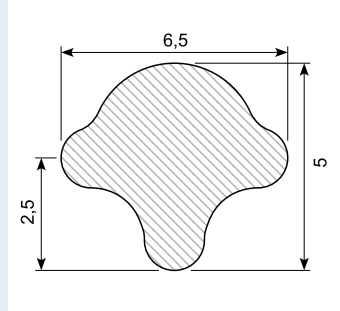

Material: EPDM black  
For 32.924

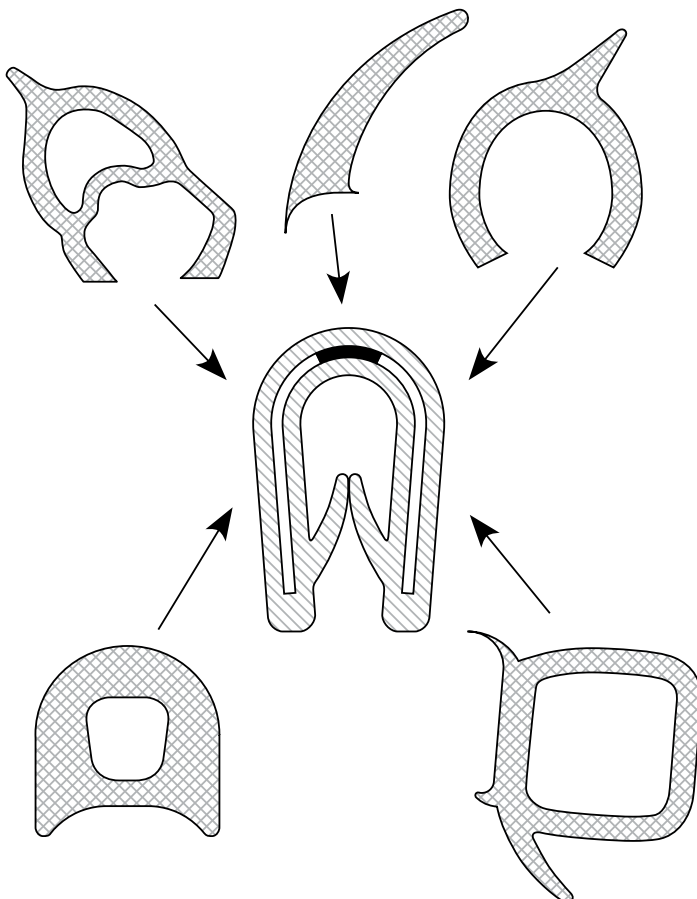

## Edge trims

Configure your own edge trim or choose from the 2.000 different we have in stock.

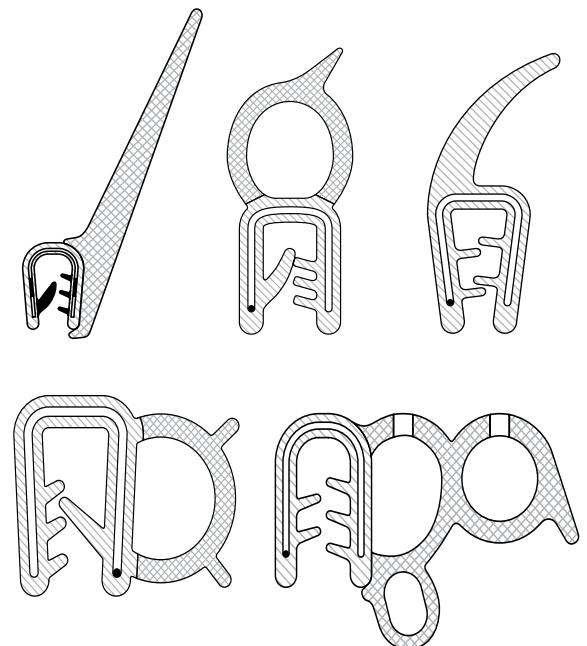

# Svampegummi / Sponge rubber

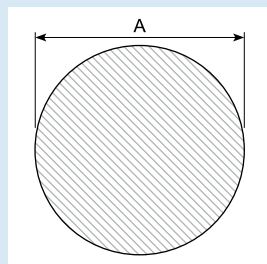

Material: Black EPDM  
Hardness: SH 16 - 20  
density 0,45 - 0,6

Material: Dark grey CR  
Hardness: SH 16 - 22  
density 0,4 - 0,6

Material: Dark grey NR  
Hardness: SH 16 - 22  
density 0,4 - 0,55

Material: Dark grey EPDM  
Hardness: SH 16 - 20  
density 0,4 - 0,5

Art.	Ø (mm)
36.7003 *	3
36.7004	4
36.7005	5
36.7006 *	6
36.7008	8
36.7009	9
36.7010	10
36.7012	12
36.7015	15
36.7050 *	50

Art.	Ø (mm)
36.103CR	3
36.104CR	4
36.105CR	5
36.106CR	6
36.107CR	7
36.108CR *	8
36.110CR *	10
36.112CR *	12
36.115CR	15 (black)
36.118CR	18 (black)
36.119CR *	19
36.120CR *	20
36.122CR	22

Art.	Ø (mm)
36.102 *	2
36.102.5 *	2,5
36.103 *	3
36.104 *	4
36.106 *	6
36.108	8
36.110 *	10
36.112	12
36.115 *	15
36.120 *	20
36.125 *	25
36.130 *	30

Art.	Ø (mm)
36.102E	2
36.1025E *	2,5
36.103E	3
36.1035E	3,5
36.1045E *	4,5
36.105E *	5
36.106E	6
36.106EG * (Light grey)	6
36.106ESP	6
36.107E	7
36.108E *	8
36.108EG * (Light grey)	8
36.109E *	9
36.110E *	10
36.111E *	11
36.112E	12
36.112EG * (Light grey)	12
36.117E	17
36.120E	20
36.122E *	22
36.125E	25
36.130EX	30
36.135E	35

Material: Black EPDM  
Hardness: SH 16 - 20  
density 0,45 - 0,6

Art.	Ø (mm)	Min. order
36.7004.5X	4,5	3.000
36.7005X	5	3.000
36.7006X	6	3.000
36.7007X	7	3.000
36.7008X	8	3.000
36.7008.5X	8,5	3.000
36.7009X	9	3.000
36.7010X	10	3.000
36.7010.5X	10,5	3.000
36.7011X	11	3.000
36.7011.5X	11,5	3.000
36.7012X	12	3.000
36.7014X	14	3.000
36.7018X	18	
36.7028X	28	
36.7064X	64	

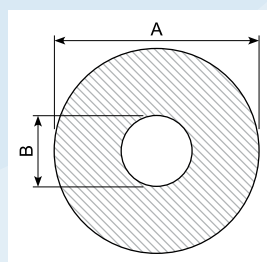

Material: Black EPDM

Art.	A x B (mm)	Min. length (m)
36.3416068 *	16 x 6,8	
36.34155105 *	15,5 x 10,5	
36.344511 *	45 x 11	
36.341840 *	40 x 18	200
36.342026 *	26 x 20	1.000
36.342030	30 x 20	Stock goods
36.342226 *	26 x 22	1.000
36.342232 *	32 x 22	500
36.342433 *	33 x 24	500
36.342529 *	29 x 25	1.000
36.342840 *	40 x 28	250

\* Skaffevare / Special order item

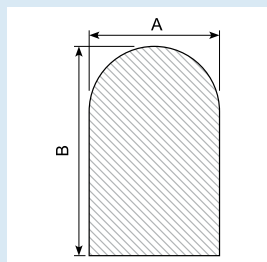

Material: NR  
Hardness: SH 16 - 20  
density 0,45 - 0,6

Art.	A x B (mm)	Color
36.197	4 x 6	Blue grey
36.198A *	6 x 8	Blue grey

Material: CR  
Hardness: SH 16 - 20  
density 0,4

Art.	A x B (mm)	Color
36.198CR *	6 x 8	Dark grey
36.200	8 x 8	Dark grey
36.202	10 x 12	Dark grey

Material: EPDM

Art.	A x B (mm)	Color
36.198	6 x 8	Grey
36.198S	6 x 8	Black
36.199	6 x 10	Light grey
36.208	10 x 20	Light grey
36.3314	12 x 17	Dark grey

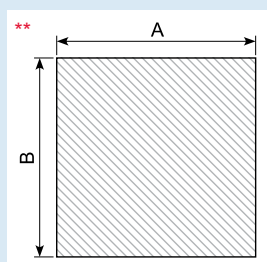

Material: Dark grey, EPDM  
Hardness: SH 14 - 16  
density 0,38 - 0,42

Art.	A x B (mm)	Varenr.	A x B (mm)	Art.	A x B (mm)	Art.	A x B (mm)
35.0806 *	8 x 6	35.1605	16 x 5	35.2515	25 x 15	35.4010	40 x 10
35.1003 *	10 x 3	35.1608 *	16 x 8	35.2520	25 x 20	35.4020	40 x 20
35.1004 *	10 x 4	35.18053	18 x 5,3	35.2525	25 x 25	35.4030 *	40 x 30
35.1005	10 x 5	35.2003	20 x 3	35.3005	30 x 5	35.4035 *	40 x 35
35.1007 *	10 x 7	35.2005	20 x 5	35.3007	30 x 7	35.4040	40 x 40
35.1008	10 x 8	35.20055 *	20 x 5,5	35.3010	30 x 10	35.4505 *	45 x 5
35.1010	10 x 10	35.2010	20 x 10	35.3012 *	30 x 12	35.5005 *	50 x 5
35.1203 *	12 x 3	35.2012 *	20 x 12	35.3015	30 x 15	35.5006 *	50 x 6
35.1209 *	12 x 9	35.2015	20 x 15	35.3020	30 x 20	35.5010 *	50 x 10
35.1212	12 x 12	35.2018 *	20 x 18	35.3025	30 x 25	35.5010E	50 x 10
35.1503 *	15 x 3	35.2020	20 x 20	35.3030	30 x 30	35.6010 *	60 x 10
35.1507	15 x 7	35.2502	25 x 2	35.3505	35 x 5	35.6040 *	60 x 40
35.1510	15 x 10	35.2505	25 x 5	35.3510 *	35 x 10		
35.1512 *	15 x 12	35.2506 *	25 x 6	35.3535	35 x 35		
35.1515	15 x 15	35.2510	25 x 10	35.4005	40 x 5		

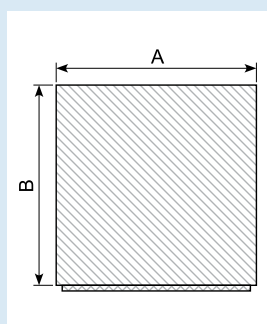

Material: Dark grey, EPDM, with adhesive  
Hardness: SH 14 - 16  
density 0,38 - 0,42

Art.	A x B (mm)	Varenr.	A x B (mm)	Art.	A x B (mm)	Art.	A x B (mm)
35.0806K *	8 x 6	35.1507K *	15 x 7	35.2207K *	22 x 7	35.3505K *	35 x 5
35.0808K *	8 x 8	35.1510K	15 x 10	35.2505K	25 x 5	35.3510K *	35 x 10
35.1003K	10 x 3	35.1512K *	15 x 12	35.2506K *	25 x 6	35.3535K *	35 x 35
35.1004K *	10 x 4	35.1515K	15 x 15	35.2508K *	25 x 8	35.4003K	40 x 3
35.1005K	10 x 5	35.1605K *	16 x 5	35.2510K	25 x 10	35.4005K	40 x 5
35.1007K *	10 x 7	35.1608K *	16 x 8	35.2515K	25 x 15	35.4010K	40 x 10
35.1008K	10 x 8	35.1708K *	17 x 8	35.2520K	25 x 20	35.4012K *	40 x 12
35.1010K	10 x 10	35.1803K *	18 x 3	35.2525K	25 x 25	35.4020K *	40 x 20
35.1203K *	12 x 3	35.18053K *	18 x 5,3	35.2806K	28 x 6	35.4030K	40 x 30
35.1204K *	12 x 4	35.1809K *	18 x 9	35.3003K	30 x 3	35.4035K	40 x 35
35.1204KL	12 x 4	35.1904K *	19 x 4	35.3005K	30 x 5	35.4040K	40 x 40
35.1206K *	12 x 6	35.2003K	20 x 3	35.3006K	30 x 6	35.4505K *	45 x 5
35.1208K *	12 x 8	35.2005K	20 x 5	35.3007K *	30 x 7	35.5006K	50 x 6
35.1209K *	12 x 9	35.20055K *	20 x 5,5	35.3010K	30 x 10	35.5010K	50 x 10
35.1212K	12 x 12	35.2010K *	20 x 10	35.3012K	30 x 12	35.5020K *	50 x 20
35.1503K *	15 x 3	35.2010KL	20 x 10	35.3015K	30 x 15	35.6002K	60 x 2
35.1504K	15 x 4	35.2012K	20 x 12	35.3020K	30 x 20	35.8020K *	80 x 20
35.1505K	15 x 5	35.2015K	20 x 15	35.3025K *	30 x 25	35.10020K *	100 x 20
35.1506K	15 x 6	35.2020K	20 x 20	35.3030K	30 x 30		

# Svampegummi / Sponge rubber

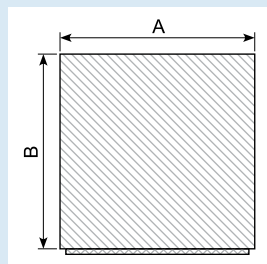

Material: White silicone  
Hardness: SH 16 - 20  
density 0,4 - 0,5

Material: Black silicone  
Hardness: SH 16 - 20  
density 0,4 - 0,5

Art.	A x B (mm)	Art.	A x B (mm)	Art.	A x B (mm)
36.1003SIH*	10 x 3	36.1812SIH*	18 x 12	36.2515SIH*	25 x 15
36.1006SIH*	10 x 6	36.2003SIH*	20 x 3	36.2520SIH	25 x 20
36.1010SIH*	10 x 10	36.2005SIH	20 x 5	36.2525SIH	25 x 25
36.1212SIH	12 x 12	36.2010SIH*	20 x 10	36.3010SIH*	30 x 10
36.1505SIH	15 x 5	36.2010SIHK* (with adhesive)	20 x 10	36.3020SIH*	30 x 20
36.1512SIH	15 x 12	36.2015SIH	20 x 15	36.4012SIH*	40 x 12
36.1610SIH*	16 x 10	36.2020SIH*	20 x 20	36.5005SIH*	50 x 5
36.1616SIH	16 x 16	36.2510SIH	25 x 10		

Art.	A x B (mm)
36.2010SIS*	20 x 10
36.2520SIS*	25 x 20

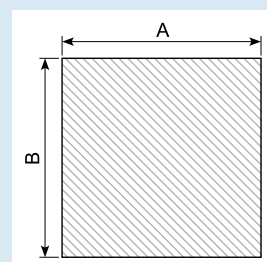

Material: Dark grey, EPDM  
Hardness: SH 16 - 20  
density 0,4 - 0,5

Art.	A x B (mm)	Art.	A x B (mm)	Art.	A x B (mm)
36.1010E (black)	10 x 10	36.2010E	20 x 10	36.4015E	40 x 15
36.1210E*	12 x 10	36.2510E	25 x 10	36.4020E	40 x 20
36.1503E*	15 x 3	36.2520E*	25 x 20	36.4025E*	40 x 25
36.1505E	15 x 5	36.2525E*	25 x 25	36.4030E	40 x 30
36.1510E	15 x 10	36.3010E	30 x 10	36.5020E*	50 x 20
36.1512E	15 x 12	36.3025E	30 x 25	36.6030E*	60 x 30
36.1612E*	16 x 12	36.3520E	35 x 20		
36.1815EG (light grey)	18 x 15	36.4010E	40 x 10		

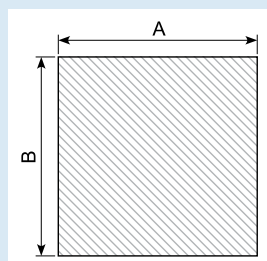

Material: Dark grey, NR  
Hardness: SH 16 - 20  
density 0,4 - 0,5

Art.	A x B (mm)	Art.	A x B (mm)	Art.	A x B (mm)
36.0505*	5 x 5	36.1605*	16 x 5	36.3005	30 x 5
36.0806*	8 x 6	36.1808G	18 x 8	36.3010	30 x 10
36.1003	10 x 3	36.1816*	18 x 16	36.3015	30 x 15
36.1005	10 x 5	36.2002*	20 x 2	36.3020	30 x 20
36.1005G (light grey)*	10 x 5	36.2003*	20 x 3	36.3030	30 x 30
36.1007*	10 x 7	36.2005	20 x 5	36.3516*	35 x 16
36.1008*	10 x 8	36.2010	20 x 10	36.4010	40 x 10
36.1010 (black)	10 x 10	36.2015	20 x 15	36.4012*	40 x 12
36.1205*	12 x 5	36.2020	20 x 20	36.4015*	40 x 15
36.1206	12 x 6	36.2503*	25 x 3	36.4025	40 x 25
36.1210	12 x 10	36.2505	25 x 5	36.5010*	50 x 10
36.1503	15 x 3	36.2510	25 x 10	36.5020	50 x 20
36.1510	15 x 10	36.2515	25 x 15	36.5025*	50 x 25
36.1512*	15 x 12	36.2520*	25 x 20	36.5030	50 x 30
36.1515	15 x 15	36.2525	25 x 25	36.6030*	60 x 30
36.1604*	16 x 4	36.3003*	30 x 3		



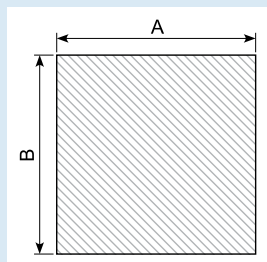

Material: Black, CR  
 Hardness: SH 18 - 25  
 density 0,5 - 0,75

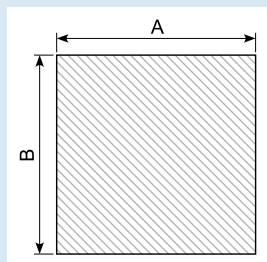

Economy  
 Material: Black  
 Hardness: Density 0,45

Art.	A x B (mm)
36.1010CR *	10 x 10
36.2010CR *	20 x 10
36.2020CR *	20 x 20
36.3015CR	30 x 15
36.4020CR *	40 x 20
36.5005CR *	50 x 5

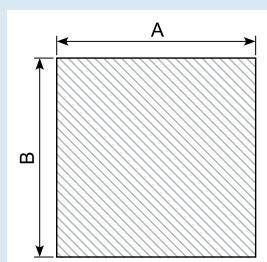

Material: NBR

Art.	A x B (mm)
36.6020NBR	60 x 20



Sponge rubber plates  
 Material: EPDM / NR  
 Color: Dark grey

Art.	Length (mm)	Thickness (mm)	Width (mm)	Quality
38.152EPDM	1.000	2	1.000	EPDM
38.153EPDM	1.000	3	1.000	EPDM
38.154EPDM	1.000	4	1.000	EPDM
38.155EPDM	1.000	5	1.000	EPDM
38.156EPDM	1.000	6	1.000	EPDM
38.158EPDM	1.000	8	1.000	EPDM
38.160EPDM	1.000	10	1.000	EPDM
38.162EPDM	1.000	12	1.000	EPDM
38.165EPDM	1.000	15	1.000	EPDM
38.170EPDM	1.000	20	1.000	EPDM
38.175EPDM	1.000	25	1.000	EPDM
38.180NR	1.000	30	1.000	NR

Art.	A x B (mm)	Min. order (m)	
36.1005X	10 x 5		
36.1505X	15 x 5		
36.2005X	20 x 5		
36.2505X	25 x 5		
36.3005X	30 x 5		
36.1406X	14 x 6		
36.1007X	10 x 7		
36.1507X	15 x 7		
36.2507X	25 x 7		
36.2008X *	20 x 8	3.000	
36.2508X *	25 x 8	3.000	
36.1010X	10 x 10		
36.1210X	12 x 10		
36.2010X *	20 x 10	3.000	
36.4010X	40 x 10		
36.5010X	50 x 10		
36.12511X	12,5 x 11		
36.1212X	12 x 12		
36.1612X	16 x 12		
36.2318X	23 x 18		
36.3015X	30 x 15		
36.3515X	35 x 15		
36.4020X *	40 x 20	3.000	
36.3020X	30 x 20		Soft corners
36.3520X	35 x 20		Soft corners
36.7013X	70 x 13		Soft corners
36.2512X	25 x 12		Soft corners

# Svampegummi / Sponge rubber

36.K608 \*

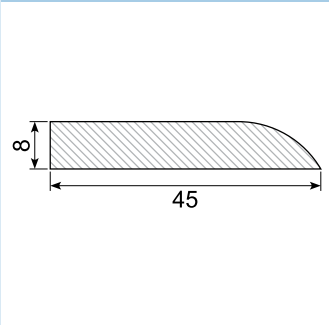

Color: Black

36.K613 \*

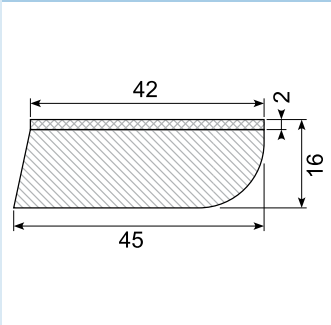

Color: Black

36.K616 \*

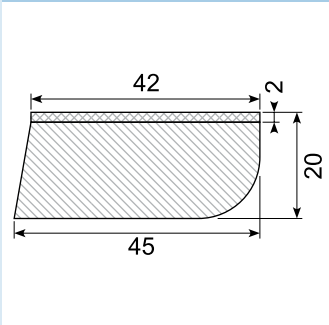

Color: Black

36.K671 \*

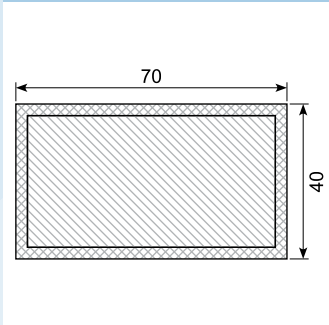

Color: Black

36.K675 \*

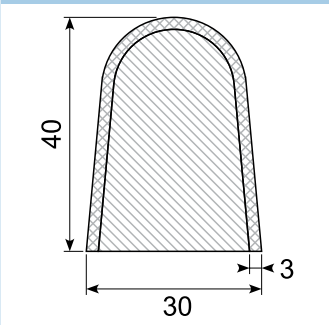

Color: Black

36.K676 \*

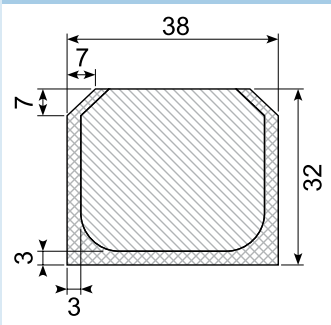

Color: Black

36.K677 \*

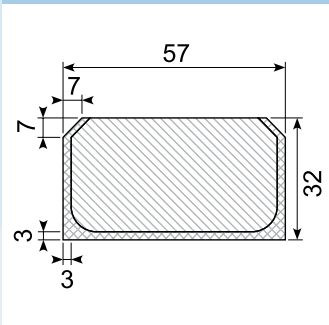

Color: Black

36.K678 \*

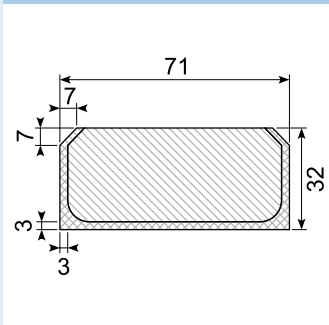

Color: Black

36.K679

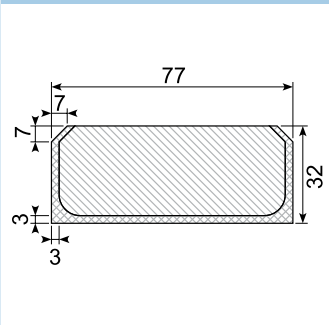

Color: Black

36.K680 \*

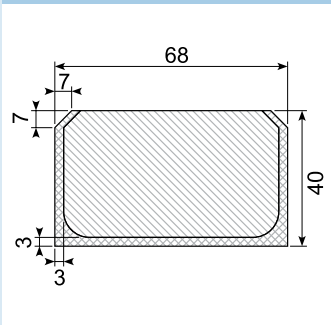

Color: Black

36.K681 \*

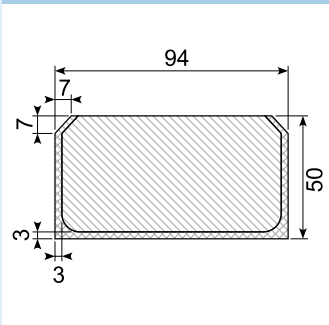

Color: Black

36.K683 \*

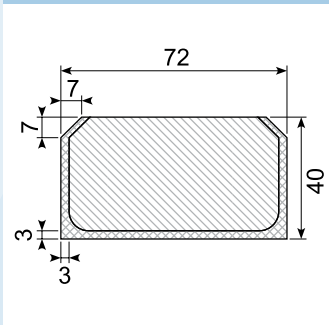

Color: Black

36.K695 \*

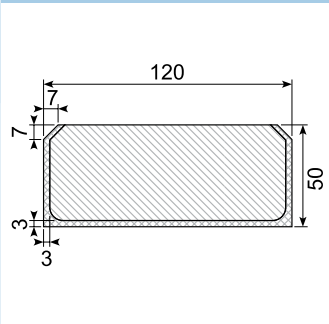

Color: Black

36.K697 \*

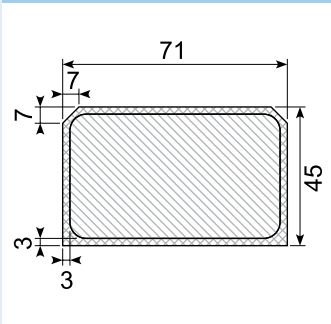

Color: Black

36.K698 \*

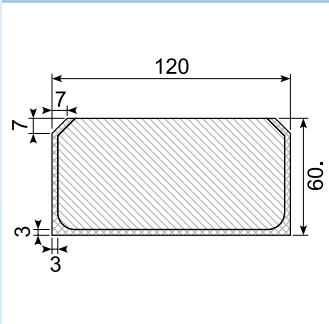

Color: Black

36.K852 \*

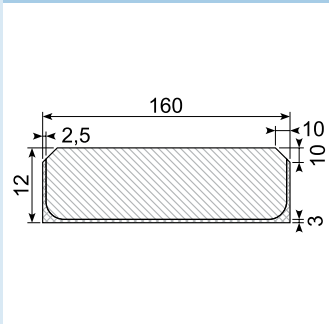

Color: Black

36.K853 \*

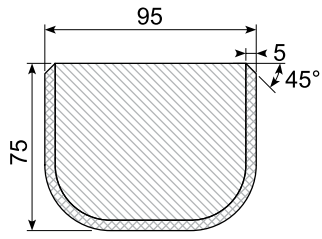

Color: Black

36.3351 \*

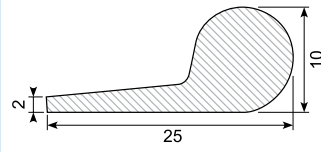

Material: EPDM black  
Hardness: SH 14 - 16  
density 0,38 - 0,4  
Min. order: 500 m

36.3354 \*

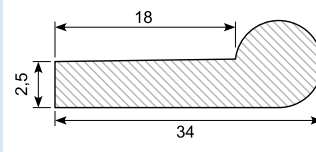

Material: NR dark grey  
Hardness: SH 16 - 20  
density 0,4  
Min. order: 500 m

36.3813

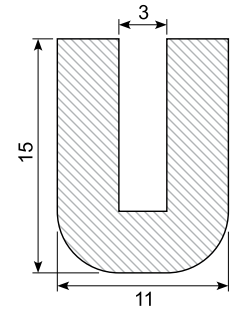

Material: EPDM dark grey  
Hardness: SH 16 - 20  
density 0,4 - 0,45

36.B380

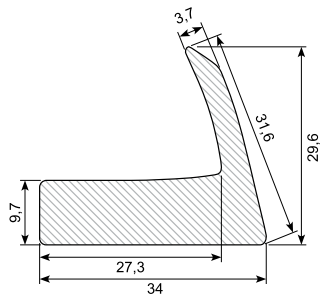

Material: EPDM  
Length: 3 m

36.3315

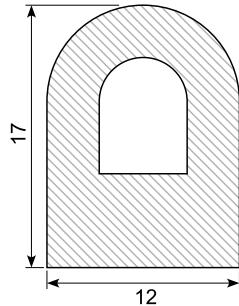

Material: EPDM black  
Hardness: SH 18 - 20  
density 0,45 - 0,55

36.3504

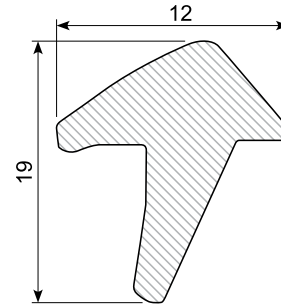

Material: EPDM dark grey  
Hardness: SH 14 - 16  
density 0,38 - 0,42

36.3881

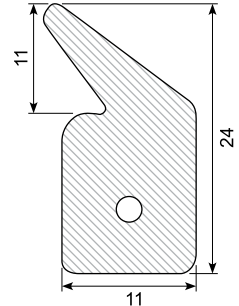

Material: EPDM grey  
Hardness: SH 16 - 20  
density 0,4 - 0,5

36.14044 \*

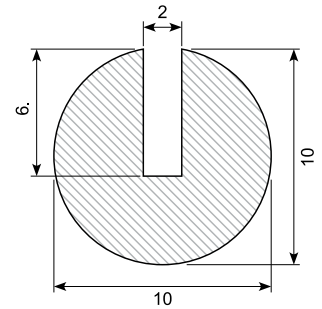

Material: EPDM  
Min. order: 500 m

36.3704

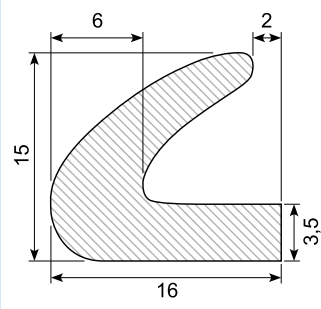

Material: NR dark grey  
Hardness: SH 20 - 25  
density 0,55 - 0,65

30.13144

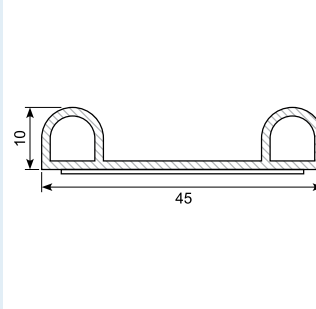

Material: EPDM  
with adhesive

36.3897

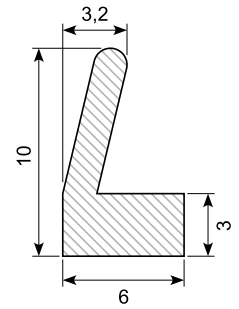

Material: Light grey EPDM

30.13315 \*

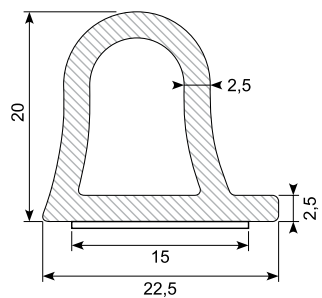

Hardness: Density 0,7  
Min. order: 1.000 m  
With adhesive

30.9884S \*

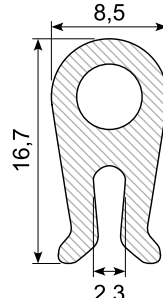

Material: EPDM  
Min. order: 3.000 m

# Svampegummi / Sponge rubber

**36.9086S**

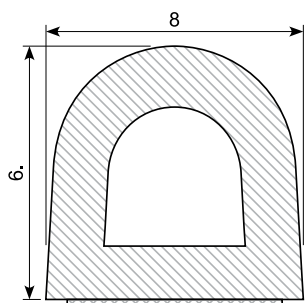

Material: Black EPDM with adhesive

**36.9088S**

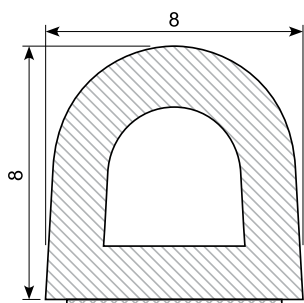

Material: Black EPDM with adhesive

**36.90810**

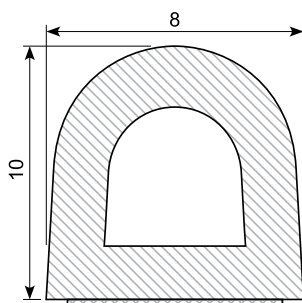

Material: Black EPDM with adhesive

**36.92117**

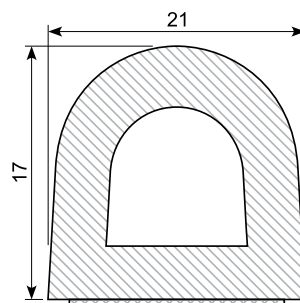

Material: Black EPDM with adhesive

**36.730810**

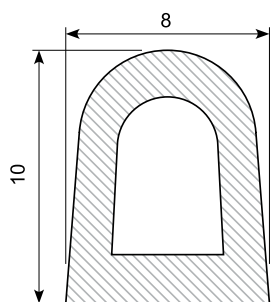

Material: EPDM  
Density: 0,35 - 0,45  
With adhesive

**36.730906 - 36.730906H \***

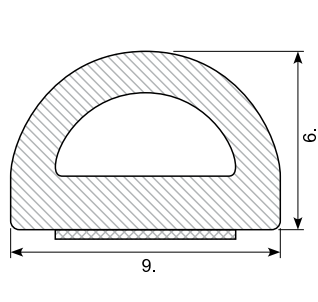

Material: White EPDM with adhesive  
Density: 0,25 - 0,35

**36.730907 - 36.730907G**

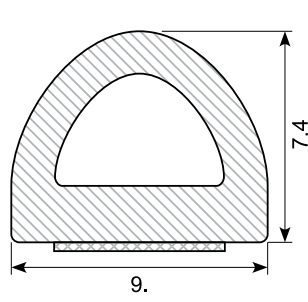

Material: Black/grey EPDM with adhesive  
Density: 0,25 - 0,35

**36.731210 - 36.731210H**

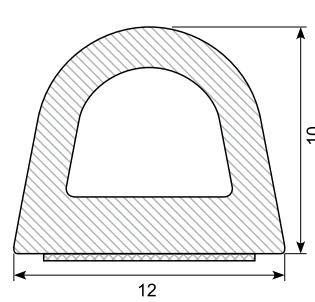

Material: EPDM with adhesive  
Density: 0,25 - 0,35

**36.731412D**

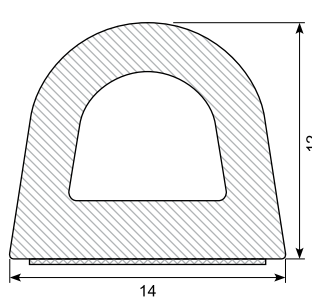

Material: EPDM with adhesive  
Density: 0,25 - 0,35

**36.732115**

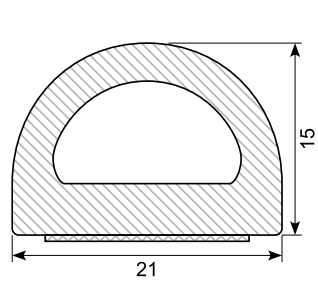

Material: EPDM with adhesive  
Density: 0,45 - 0,55

**36.80955S**

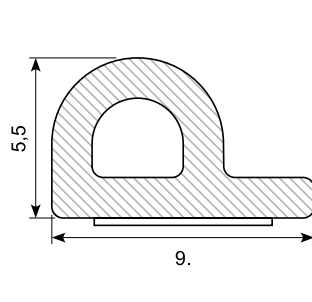

Material: Black EPDM with adhesive

**36.730955**

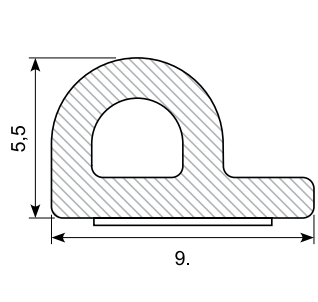

Material: Black EPDM with adhesive  
Density: 0,25 - 0,35

**36.730955G**

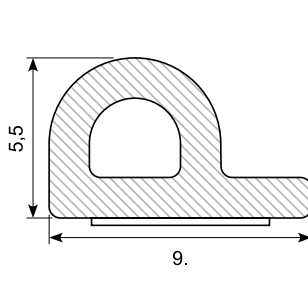

Material: Light grey with adhesive  
Density: 0,25 - 0,35

**36.730955H**

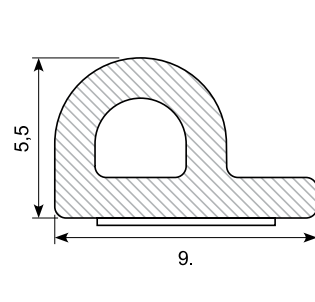

Material: White with adhesive  
Density: 0,25 - 0,35

36.721508

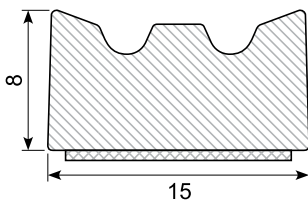

Material: Black EPDM  
Density: 0,35 - 0,45  
With adhesive

36.720802

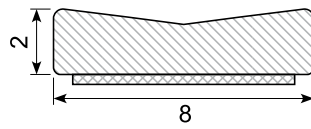

Material: Black EPDM  
Density: 0,35 - 0,45  
With adhesive

36.720803

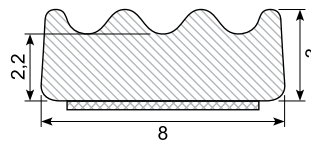

Material: Black EPDM  
Density: 0,35 - 0,45  
With adhesive

36.720904

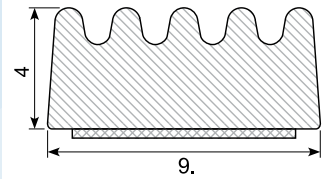

Material: Black EPDM  
Density: 0,35 - 0,45  
With adhesive

36.720804

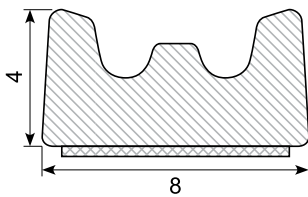

Material: Black EPDM  
Density: 0,35 - 0,45  
With adhesive

36.7213564

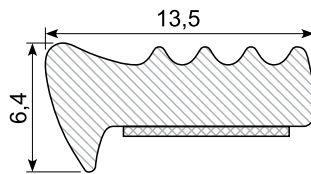

Material: Black EPDM  
Density: 0,35 - 0,45  
With adhesive

36.721503

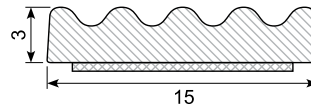

Material: Black EPDM  
Density: 0,35 - 0,45  
With adhesive

36.720903

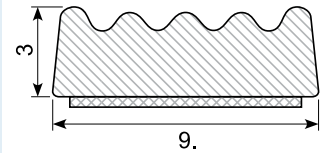

Material: Black EPDM  
Density: 0,35 - 0,45  
With adhesive

36.721202

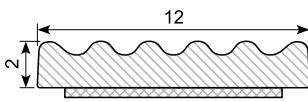

Material: Black EPDM  
Density: 0,35 - 0,45  
With adhesive

36.721504

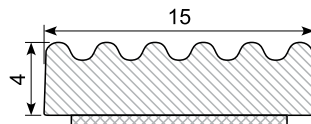

Material: Black EPDM  
Density: 0,35 - 0,45  
With adhesive

36.722004

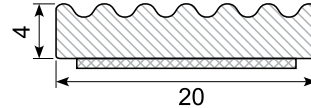

Material: Black EPDM  
Density: 0,35 - 0,45  
With adhesive

36.721004

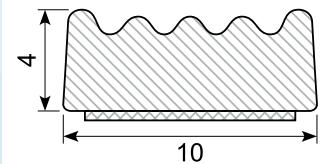

Material: Black EPDM  
Density: 0,35 - 0,45  
With adhesive

36.721006

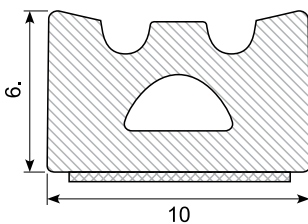

Material: Black EPDM  
Density: 0,35 - 0,45  
With adhesive

36.721203

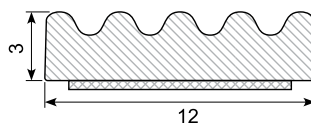

Material: Black EPDM  
Density: 0,35 - 0,45  
With adhesive

36.721005

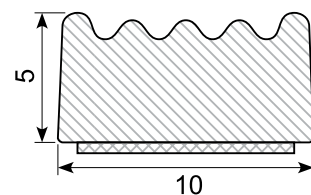

Material: Black EPDM  
Density: 0,35 - 0,45  
With adhesive

36.721508B

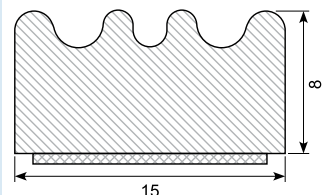

Material: Black EPDM  
Density: 0,25 - 0,35  
With adhesive

# Cellegummi / Cellular rubber

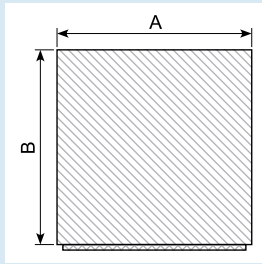

Material: Black EPDM,  
with adhesive  
Hardness: SH 25  
density 0,14

Art.	A x B (mm)	Art.	A x B (mm)	Art.	A x B (mm)	Art.	A x B (mm)
36.60403 *	4 x 3	36.61005	10 x 5	36.61530 *	15 x 30	36.63005	30 x 5
36.60404 *	4 x 4	36.61008	10 x 8	36.61603	16 x 3	36.63010	30 x 10
36.60405	4 x 5	36.61010	10 x 10	36.61710 *	17 x 10	36.63012	30 x 12
36.60503	5 x 3	36.61203	12 x 3	36.61808	18 x 8	36.64003	40 x 3
36.60505	5 x 5	36.61204 *	12 x 4	36.62002	20 x 2	36.64005 *	40 x 5
36.60605 *	6 x 5	36.61205	12 x 5	36.62003	20 x 3	36.64010	40 x 10
36.60802	8 x 2	36.61310 *	13 x 10	36.62004	20 x 4	36.64015	40 x 15
36.60803	8 x 3	36.61502 *	15 x 2	36.62005	20 x 5	36.65003	50 x 3
36.60804	8 x 4	36.61503	15 x 3	36.62008	20 x 8	36.65010	50 x 10
36.60805 *	8 x 5	36.61505	15 x 5	36.62010	20 x 10	36.66004 *	60 x 4
36.60808	8 x 8	36.61506	15 x 6	36.62305 *	23 x 5	36.66004X	60 x 4
36.61001	10 x 1	36.61508	15 x 8	36.62502	25 x 2	36.67502 *	75 x 2
36.61002	10 x 2	36.61510	15 x 10	36.62506	25 x 6		
36.61003	10 x 3	36.61512	15 x 12	36.62510	25 x 10		
36.61004	10 x 4	36.61518 *	15 x 18	36.62525 *	25 x 25		

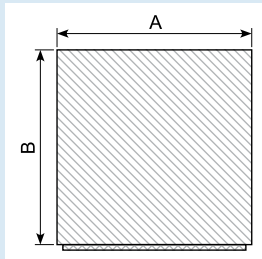

Material: CR, with  
standard  
adhesive.  
CR-5952 tape  
without glass-  
fiber  
Hardness: SH 25  
density 0,14

Art.	A x B (mm)	Art.	A x B (mm)	Art.	A x B (mm)
36.60802CR	8 x 2	36.62004CR *	20 x 4	36.65005CR-5952 *	50 x 5
36.60804CR	8 x 4	36.63005CR-5952 *	30 x 5	36.65007CR *	50 x 7
36.60808CR *	8 x 8	36.63030CR	30 x 30	36.68005CR *	80 x 5
36.61003CR *	10 x 3	36.63204CR *	32 x 4	36.68005CR-5952 *	80 x 5
36.61010CR *	10 x 10	36.64005CR *	40 x 5		
36.61609CR *	16 x 9	36.65005CR *	50 x 5		

Cellular rubber plates no adhesive

Material: EPDM  
Color: Black

Art.	Length (mm)	Thickness (mm)	Width (mm)	Quality
38.188 *	1.000	40	2.000	EPDM
38.189 *	1.000	50	2.000	EPDM

Cellular rubber plates with adhesive

Material: EPDM  
Color: Black

Art.	Length (mm)	Thickness (mm)	Width (mm)	Quality
38.160E/K	1.000	10	2.000	EPDM
38.170E/K *	1.000	20	2.000	EPDM
38.175E/K *	1.000	25	2.000	EPDM

Cellular rubber plates

Material: CR  
Color: Black

Art.	Length (mm)	Thickness (mm)	Width (mm)	Quality
38.190 *	1.000	10	1.400	CR
38.191 *	1.000	15	1.400	CR

34.601\* / 34.601G\*

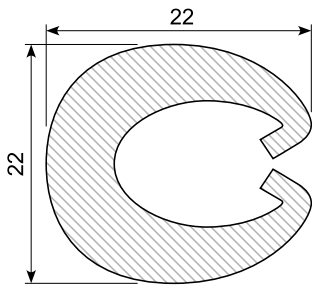

Material: PVC black  
Min. order: 5 m  
34.601G\* PVC grey  
Min. order: 50-500m

34.602\* / 34.602G\*

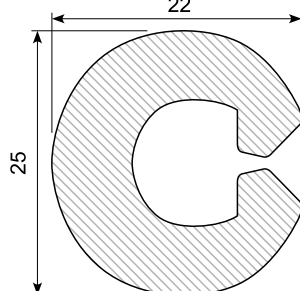

Material: PVC black  
Min. order: 5 m  
34.602G\* PVC grey  
Min. order: 50 m

34.603 / 34.603G

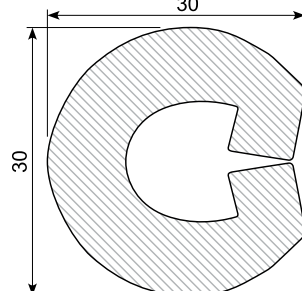

Material: PVC black  
34.603G Grey

34.604\*

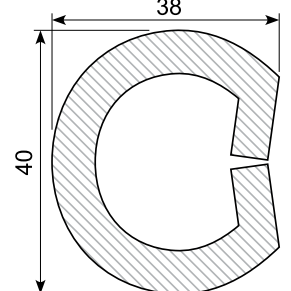

Material: PVC black  
Min. order: 50 m

34.7102-50\*

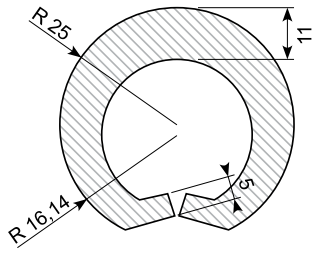

Material: PVC black  
Min. order: 5 m

34.614\*

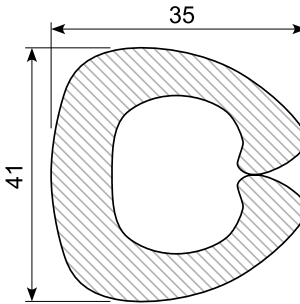

Material: PVC black  
Min. order: 50 m

34.62105\*

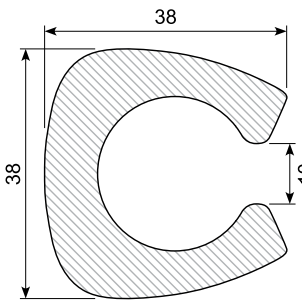

Material: EPDM black  
Min. order: 5 m

34.3032\*

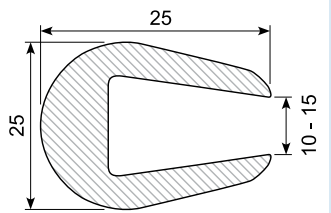

Material: PVC black  
Min. order: 51 m

34.641\*

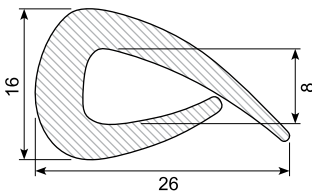

Material: PVC black  
Min. order: 5 m

34.643\*

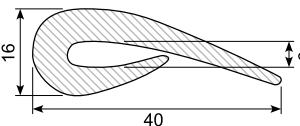

Material: PVC black  
Min. order: 50 m

34.644\*

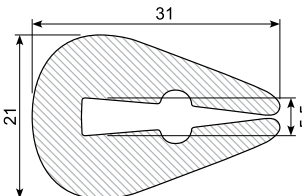

Material: PVC black  
Min. order: 50 m

34.620010\*

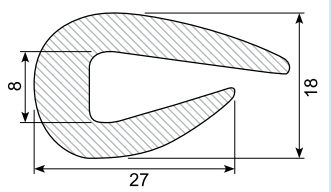

Material: PVC black  
Min. order: 5 m

34.620040

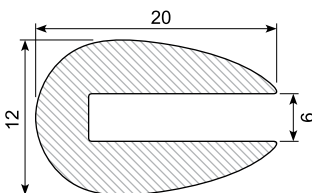

Material: PVC black  
Min. order: 5 m

34.620210

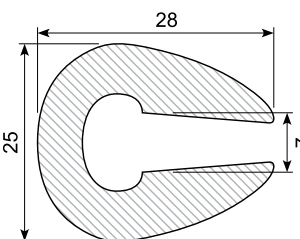

Material: PVC black  
Min. order: 5 m

34.613

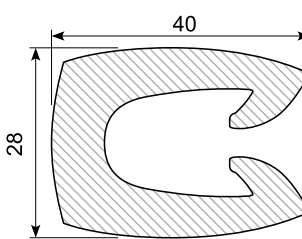

Material: PVC black

34.7196\*

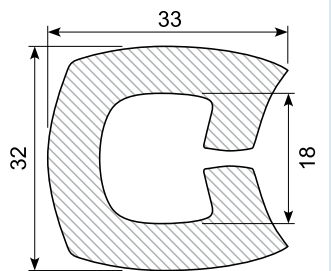

Material: PVC black  
Min. order: 20 m

34.7199 \*

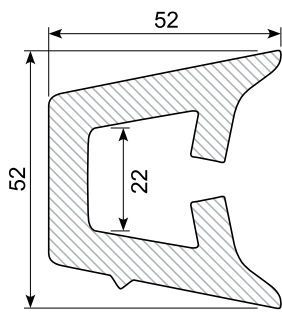

Material: PVC black  
Min. order: 25 m

34.620140 \*

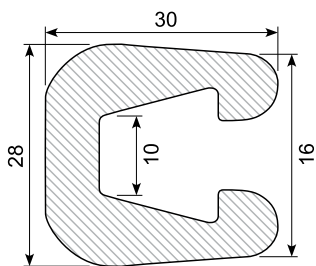

Material: PVC black  
Min. order: 5 m

34.3011

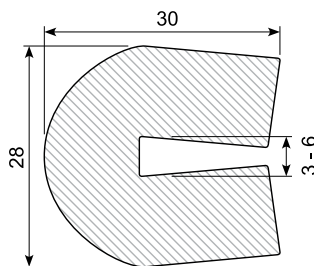

Material: PVC black

34.62110 \*

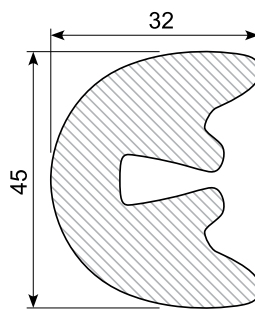

Material: PVC black  
Min. order: 5 m

34.62039 \*

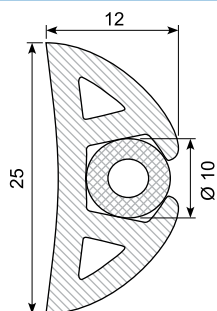

Material: PVC black  
Min. order: 5 m

34.62040

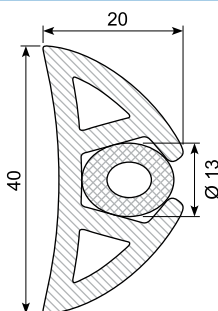

Material: PVC black

34.620420 \*

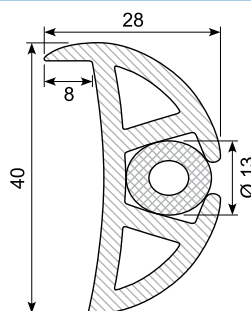

Material: PVC black  
Min. order: 5 m

34.62041

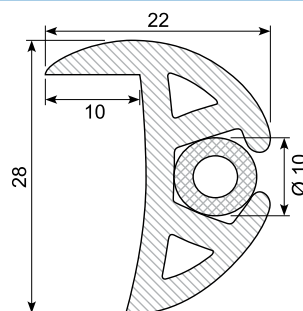

Material: PVC black

34.624 \*

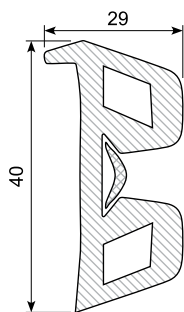

Material: PVC black  
Min. order: 50 m

34.625 \*

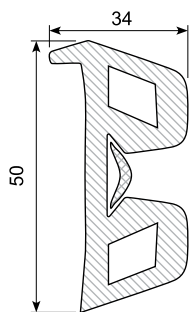

Material: PVC black  
Min. order: 5 m

34.626 \*

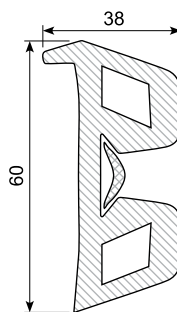

Material: PVC black  
Min. order: 5 m

34.636

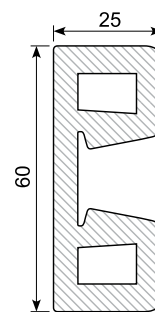

Material: PVC black

34.637 \*

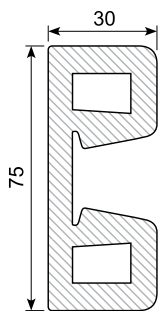

Material: PVC black  
Min. order: 20 m

34.3020

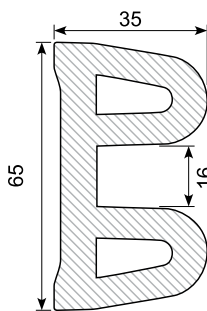

Material: PVC black

34.7514 \*

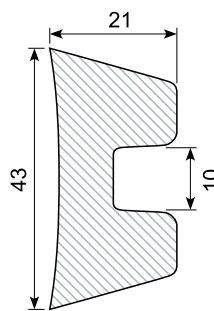

Material: PVC black  
Min. order: 5 m

34.62610S \*

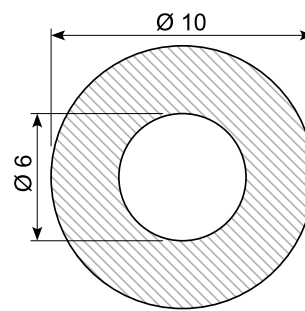

Material: PVC black  
Min. order: 5 m



34.62713H \*

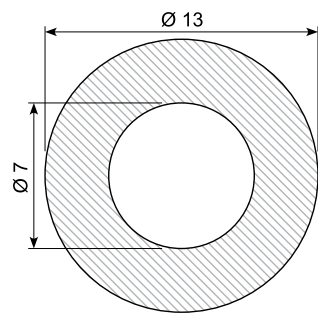

Material: PVC white  
Min. order: 5 m

34.62713S \*

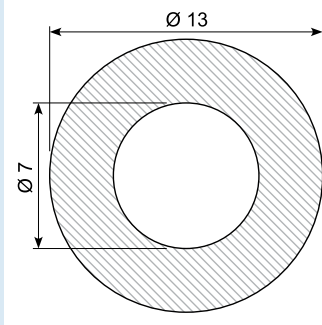

Material: PVC black  
Min. order: 5 m

34.677

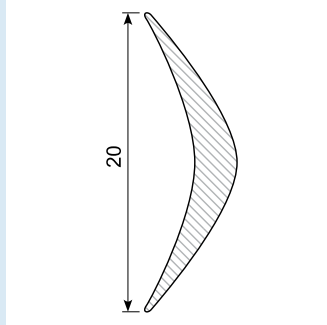

Material: PVC white

34.678 \*

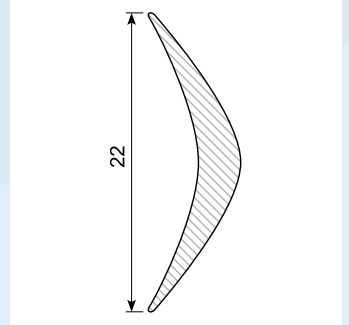

Material: PVC white  
Min. order: 5 m

34.676S \*

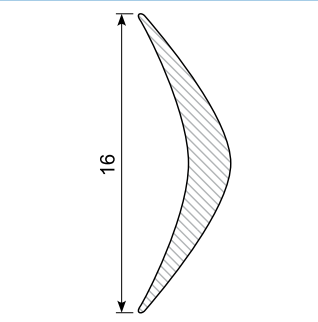

Material: PVC black for 34.624  
and 34.7106  
Min. order: 300 m

34.608

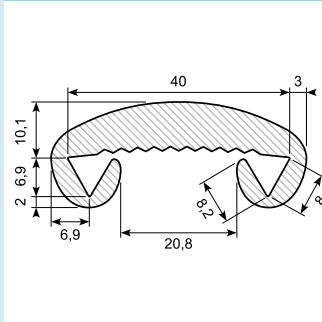

Material: PVC black  
Current stock available

34.608X

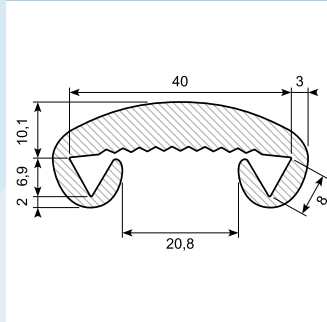

Material: PVC black

34.609X

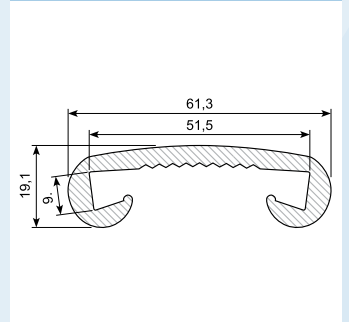

Material: PVC black

34.606 \*

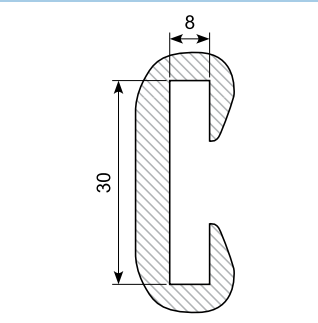

Material: PVC black  
Min. order: 500 m

34.607 \*

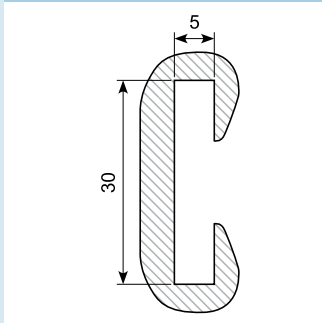

Material: PVC black  
Min. order: 100 m

34.606X \*

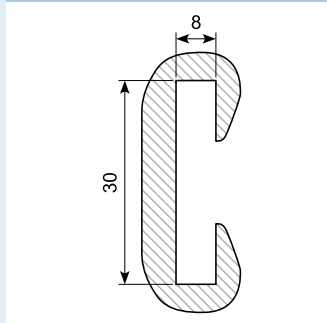

Material: PVC black  
Min. order: 500 m

34.607X \*

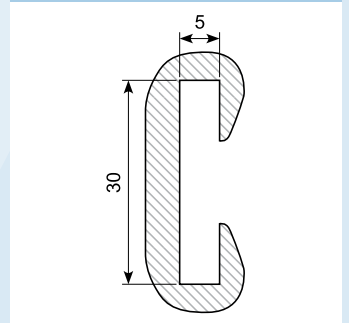

Material: PVC black  
Min. order: 500 m

**45.206AL**

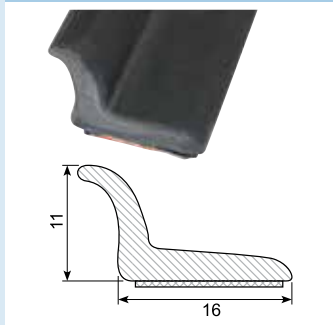

Material: PVC gutter with adhesive  
Length: 2 m

**45.224**

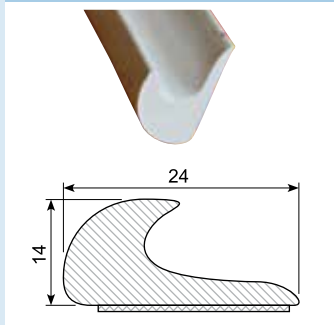

Material: White PVC gutter with adhesive  
Length: 25 m

**45.217C \***

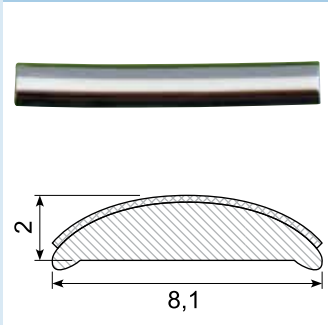

Material: Chrome PVC with adhesive  
Length: 5 m

**45.221C \***

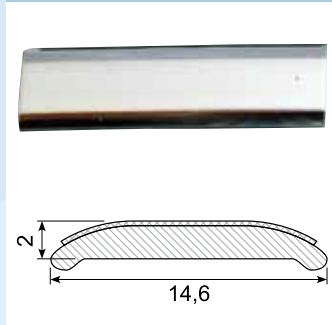

Material: Chrome PVC with adhesive  
Length: 5 m

**45.347C \***

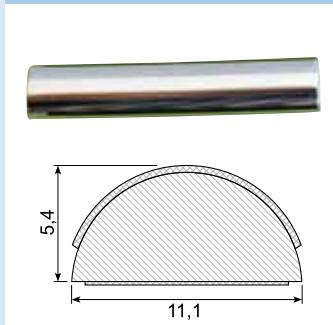

Material: Chrome PVC with adhesive  
Length: 5 m

**45.884C \***

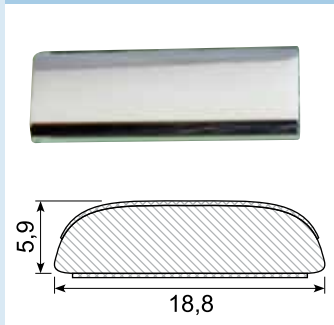

Material: Chrome PVC with adhesive  
Length: 5 m

**45.383C \***

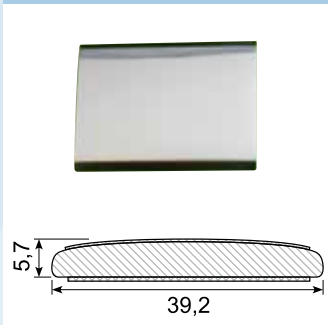

Material: Chrome PVC with adhesive  
Length: 5 m

**45.388C \***

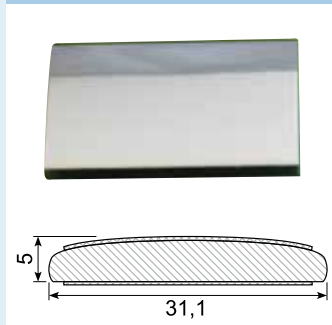

Material: Chrome PVC with adhesive  
Length: 5 m

**45.705C \***

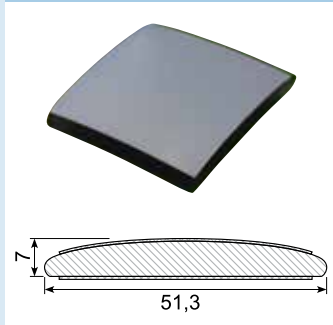

Material: Chrome PVC with adhesive  
Length: 5 m

**45.832**

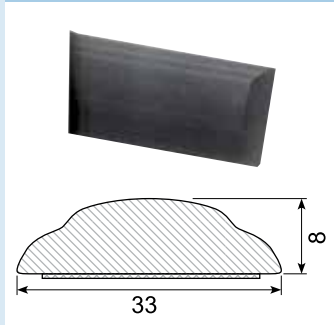

Material: PVC with adhesive  
Length: 25 m

**45.836**

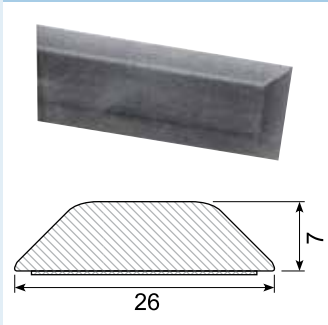

Material: PVC with adhesive  
Length: 25 m

**45.837**

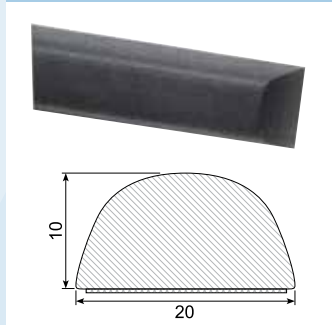

Material: PVC with adhesive  
Length: 25 m  
Hardness: SH 74 - 76  
Density: 1,32

**45.839 \***

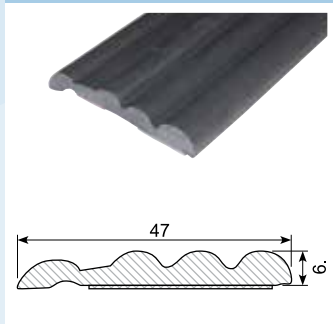

Material: PVC with adhesive  
Length: 25 m  
Min. order: 300 m

**45.872**

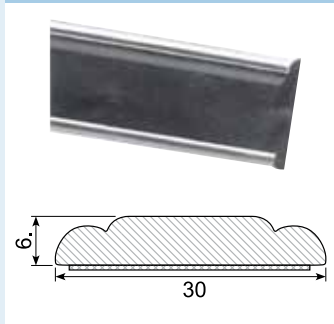

Material: PVC with adhesive  
Length: 25 m

**45.874**

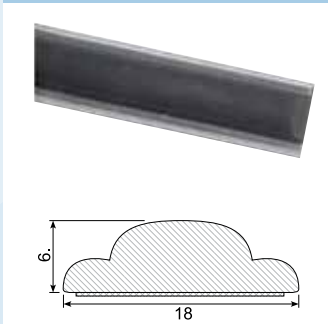

Material: PVC with adhesive  
Length: 25 m

**45.882**

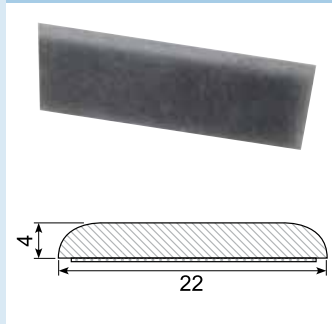

Material: PVC with adhesive  
Length: 50 m

45.886 / 45.886G

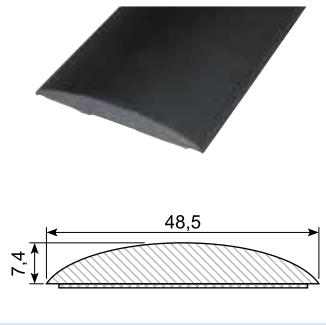

Material: Black PVC with adhesive  
 Length: 25 m  
 45.886G: Grey

45.894 \*

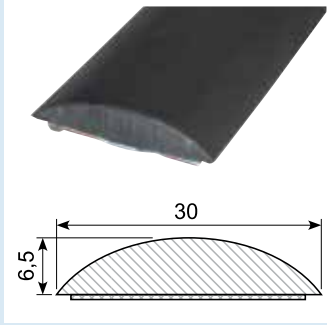

Material: PVC with adhesive  
 Length: 25 m  
 Min. order: 300 m

45.980A \*

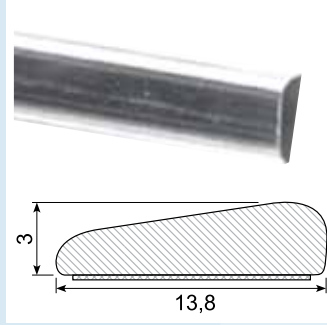

Material: Chrome PVC with adhesive  
 Length: 25 m  
 Min. order: 500 m

45.980K \*

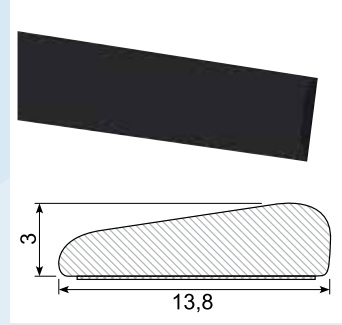

Material: PVC with adhesive  
 Length: 340 mm  
 Min. order: 1.400 pcs.  
 Example fix lengths

45.980S \*

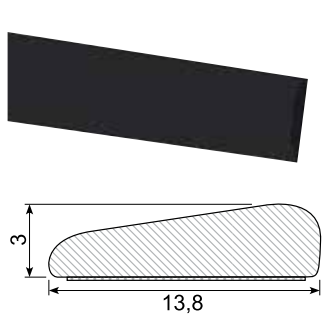

Length: 25 m  
 Min. order: 500 m

45.102G

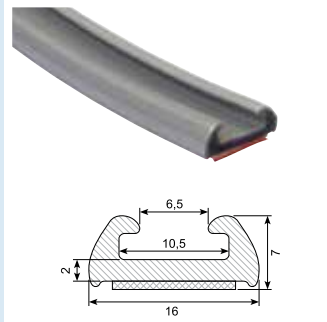

Length: 25 m

45.308C / 45.308C-50 \*

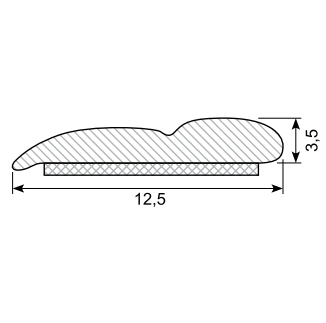

Material: Chrome PVC  
 Length: 5 m  
 45.308C-50 (50 m)  
 Min. order: 300 m

45.309C / 45.309C-50 \*

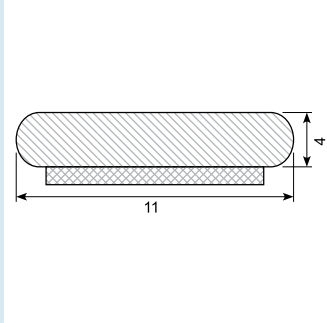

Material: Chrome PVC  
 Length: 5 m  
 45.309C-50 (50 m)  
 Min. order: 300 m

45.216C-50 \*

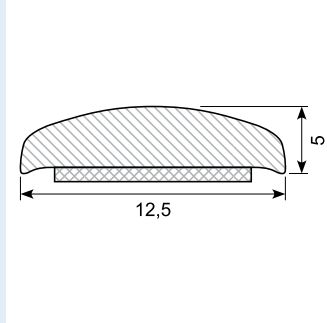

Material: Chrome PVC  
 Length: 50 m  
 Min. order: 300 m

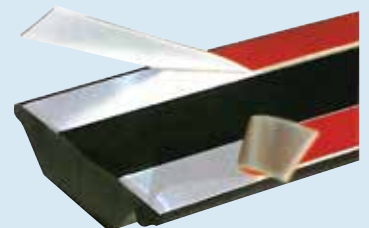
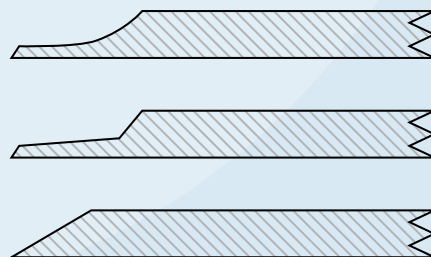

45.123 \*

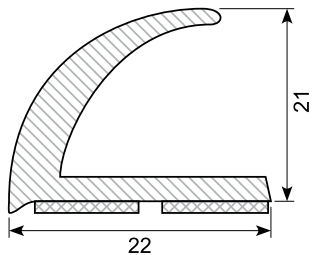

Material: PVC gutter with adhesive  
Length: 25 m  
Min. order: 300 m

45.393 \*

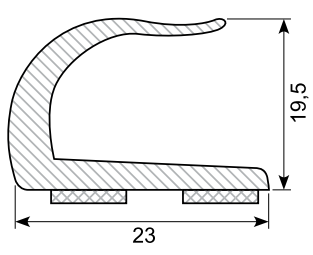

Material: PVC gutter with adhesive  
Length: 25 m  
Min. order: 300 m

45.394 \*

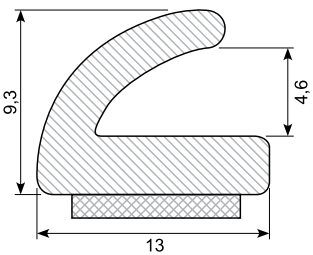

Material: PVC gutter with adhesive  
Length: 25 m  
Min. order: 300 m

45.901 \*

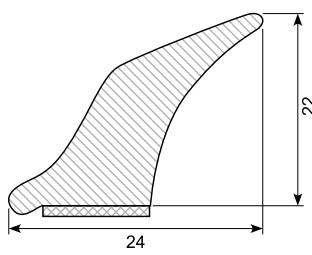

Material: PVC gutter with adhesive  
Length: 25 m  
Min. order: 300 m

45.2031024 \*

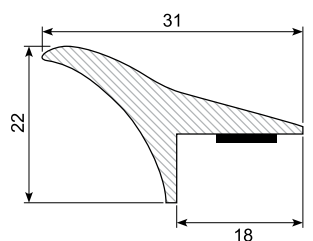

PVC universal wheel arch panel with adhesive. Set of 4 pcs.  
Length: 1,5 m

45.20511046 \*

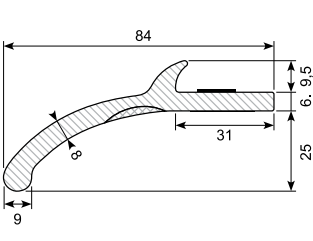

PVC universal wheel arch panel with adhesive. Coil.  
Color: Black  
Length: 6 m

45.20511091 \*

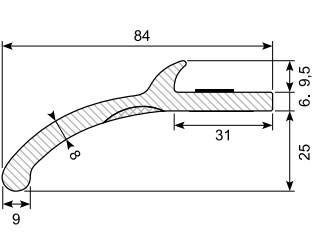

PVC universal wheel arch panel with adhesive. Set of 2 pcs.  
Length: 1,5 m

45.2051445 \*

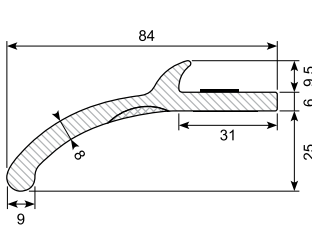

PVC universal wheel arch panel with adhesive. Coil.  
Length: 12,5 m

45.235N1057 \*

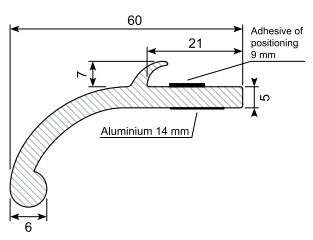

PVC universal wheel arch panel with adhesive. Coil.  
Color: Black  
Length: 6 m

45.235N429 \*

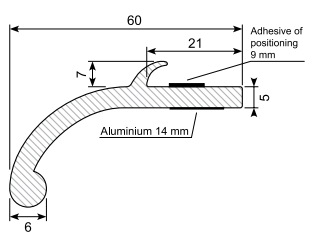

PVC universal wheel arch panel with adhesive. Coil.  
Color: Black  
Length: 12,5 m

45.235NG1057 \*

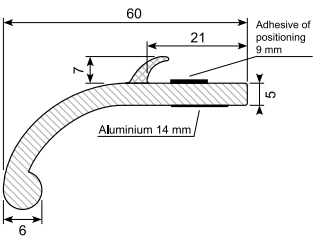

PVC universal wheel arch panel with adhesive. Coil.  
Color: Grey / black  
Length: 6 m

45.235NG429 \*

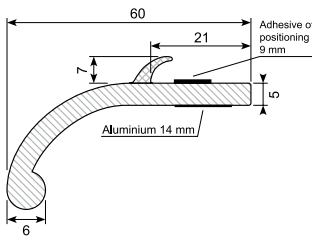

PVC universal wheel arch panel with adhesive. Coil.  
Color: Grey / black  
Length: 12,5 m

31.4281 \*\*

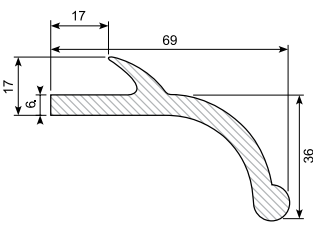

Material: EPDM black  
Hardness: SH 85  
Length: 2,6 m

39.171J / 39.171G

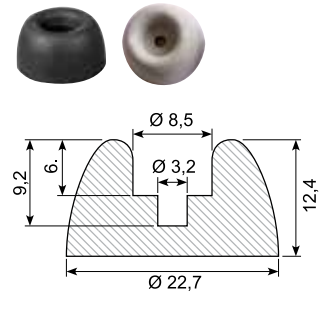

Material: Black  
39.171G: Light grey

39.175J

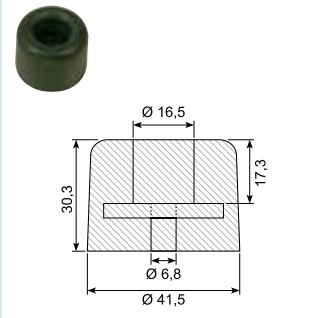

Material: Black NR  
Hardness: 78

39.175H \*

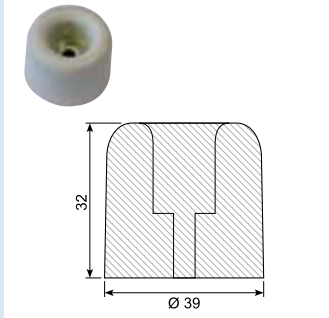

Min. order: 2.000 pcs.

39.632J

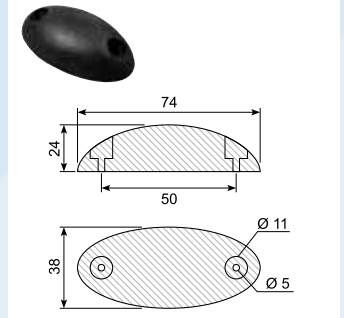

Material: Black

39.167G

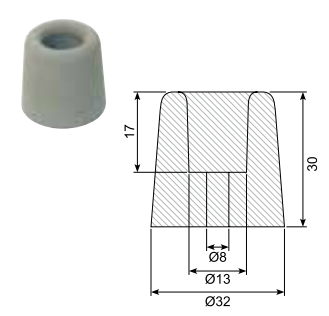

Grey rubber buffer

39.168G

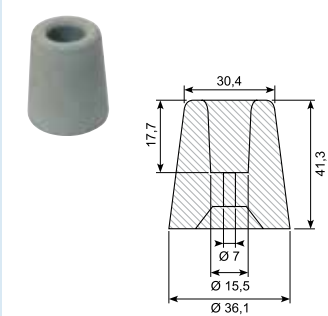

Grey rubber buffer

39.169G

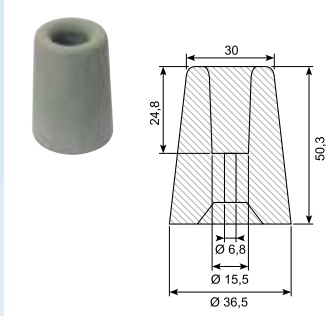

Grey rubber buffer

39.170G

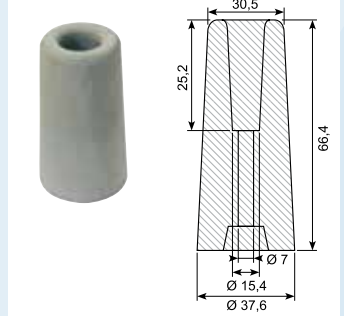

Grey rubber buffer

39.174

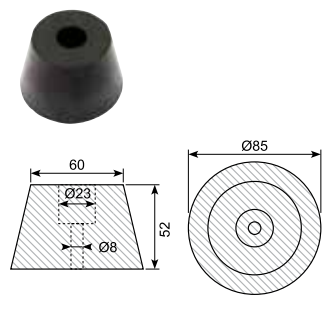

Material: Black NR / SBR

39.177

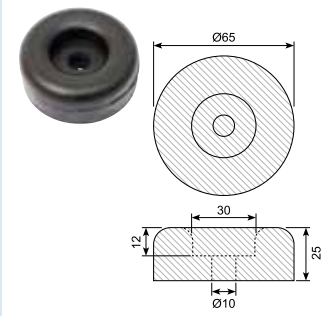

Material: Black NR / SBR

39.178

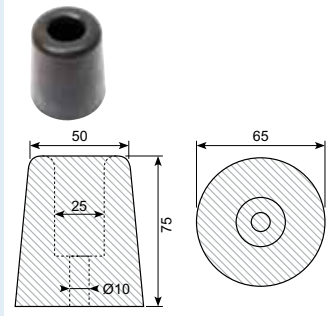

Material: Black NR / SBR

39.179

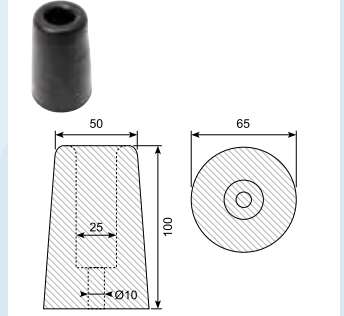

Material: Black NR / SBR

39.632A

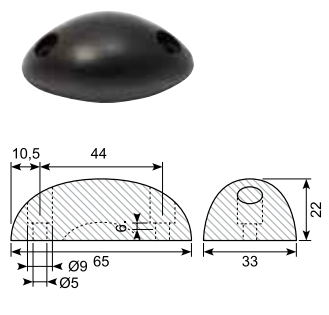

Material: Black NR / SBR

39.632B

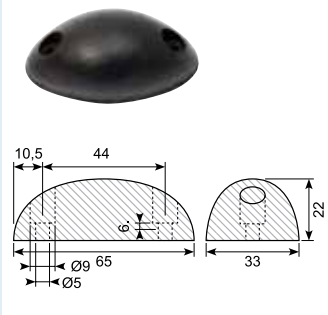

Material: Black NR / SBR

39.632C

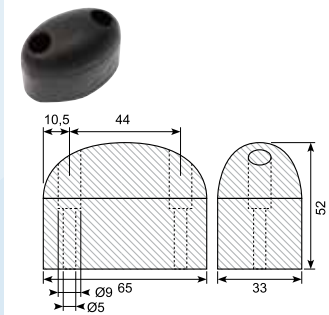

Material: Black NR / SBR

39.172

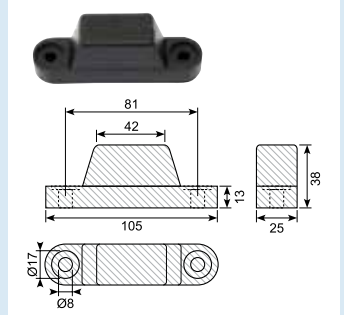

Material: Black NR / SBR

39.173

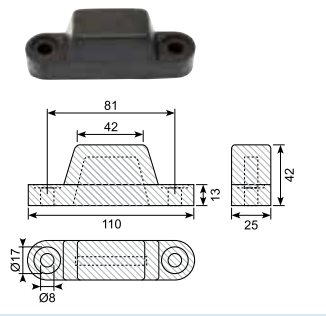

Material: Black NR / SBR

39.626J\*\*

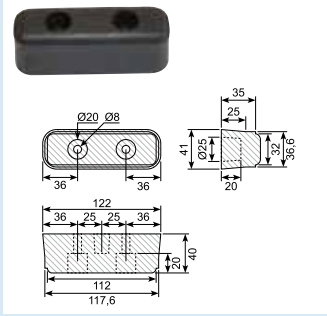

Material: Black NR  
Hardness: SH 85

39.637

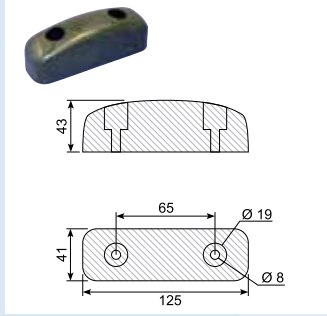

Vehicle bumper  
Material: Black NR / SBR

39.625

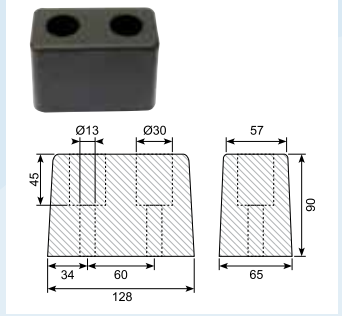

Material: NR / SBR

39.624

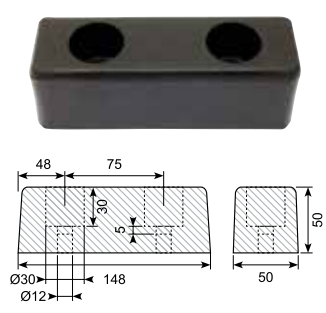

Material: Black NR / SBR

39.623J

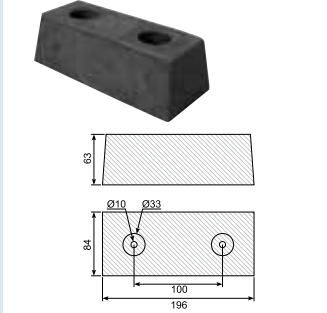

Rubber buffer, slightly conical  
Material: NR

39.620J

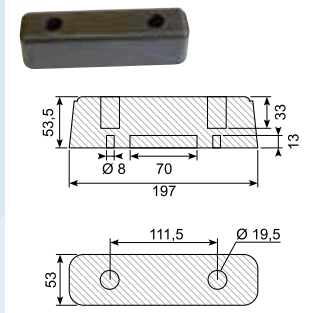

Rubber buffer with washers  
Material: Black NR  
Hardness: SH 85

39.638

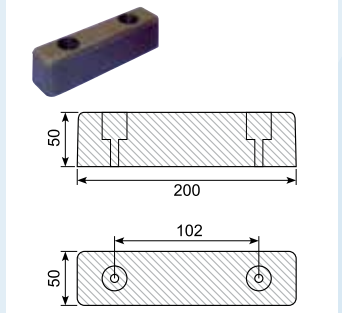

Vehicle bumper  
Material: Black NR / SBR

39.181061

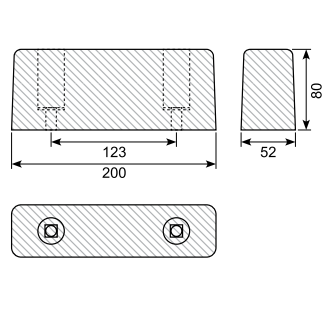

Material: NR/SBR

39.181052

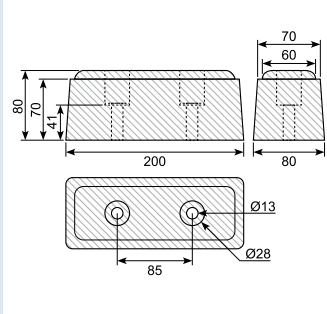

Material: NR/SBR

39.627

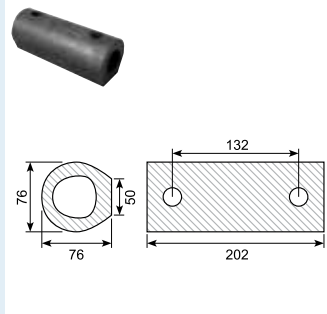

Material: SBR black

39.181060

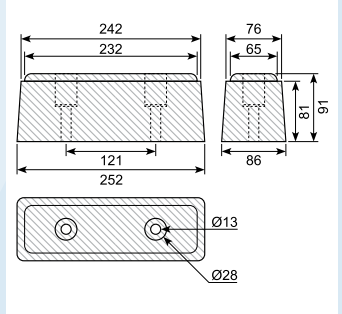

Material: NR/SBR

39.360

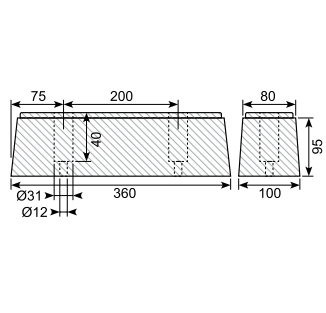

Material: Black NR / SBR

39.628

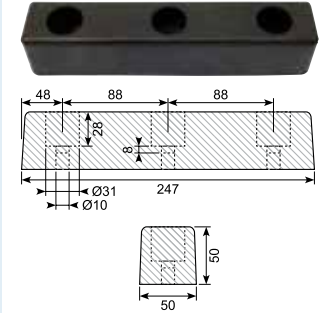

Material: NR/SBR

39.646

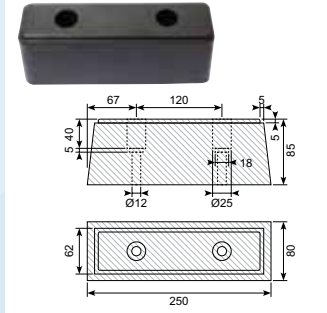

Material: Black NR / SBR  
Weight: 1.800 g

39.629

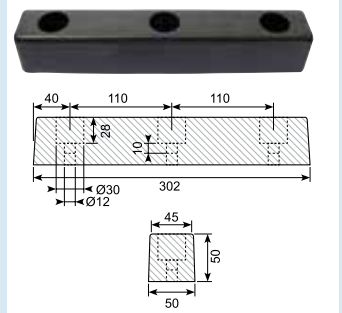

Material: Black NR / SBR

39.634

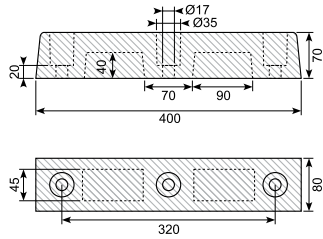

Buffer with steel washers and steel casing, 3 holes for 16 mm bolt.  
Material: EPDM black

39.630

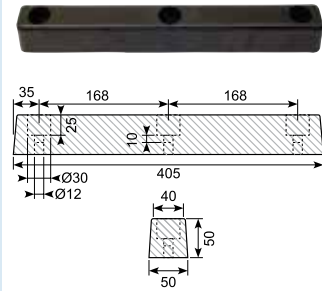

Material: Black NR / SBR

39.634P

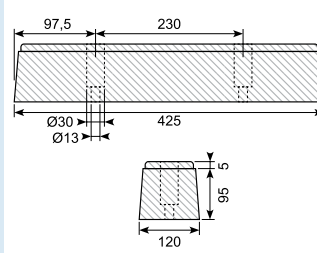

Material: Black NR / SBR

39.647 \*

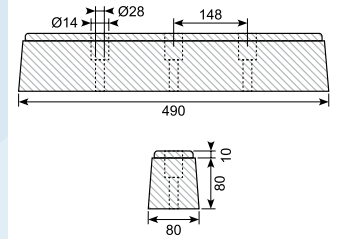

Material: Black NR / SBR

39.650 \*

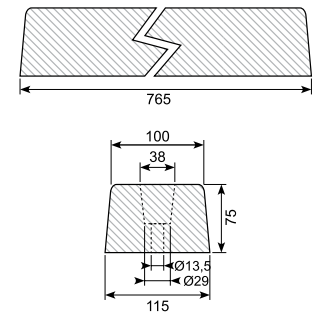

Material: Black NR / SBR

39.631X

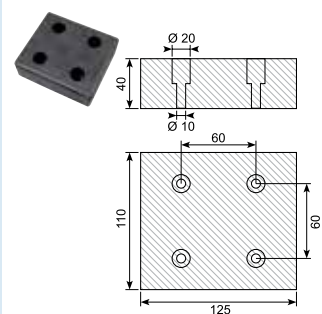

Material: SBR black  
Hardness: SH 75

39.651A

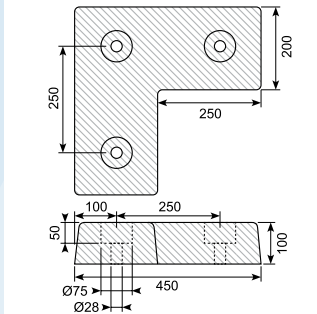

Material: NR / SBR  
39.651: SBR + rayon

39.652

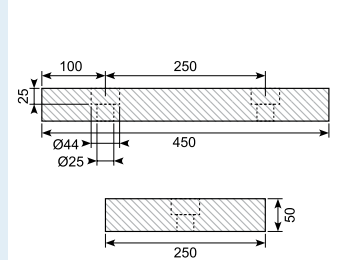

Material: Black NR / SBR

39.653

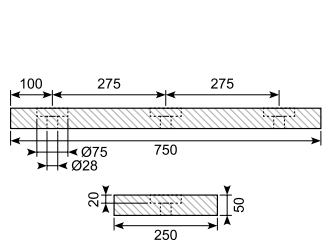

Material: Black NR / SBR

39.644

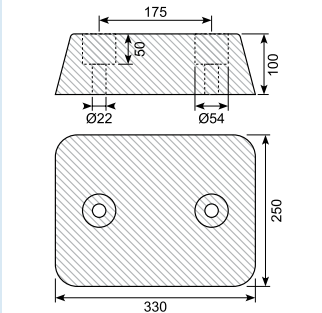

Material: SBR + rayon  
39.644A: NR/SBR \*

39.631A

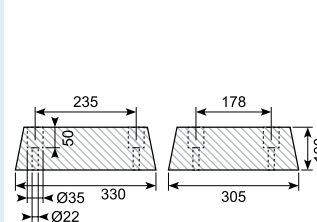

Material: NR / SBR

39.648

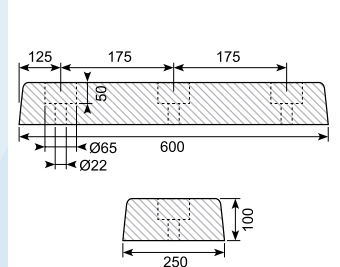

Material: Black NR / SBR

39.649

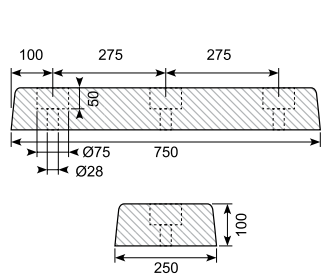

Material: Black NR / SBR

39.642X

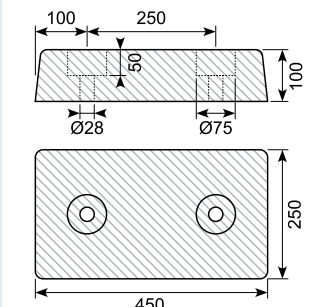

Material: NR / SBR (Economy)  
39.642 SBR + rayon \*

39.643X

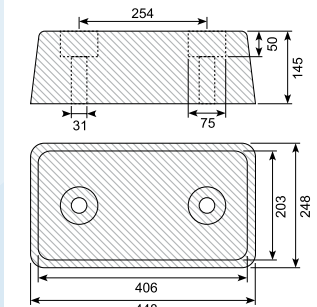

Material: NR / SBR (Economy)

39.M24

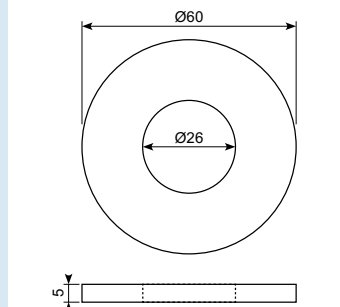

M24 washer for rubber buffer

# Gummibuffer / Rubber buffer

39.636H \*\*

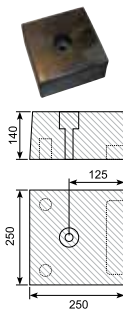

Buffer, vulcanized new rubber.

39.635X \*\*

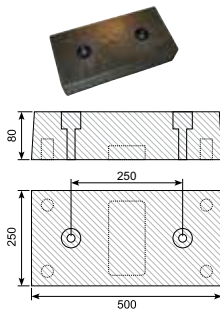

Buffer, vulcanized new rubber.

39.635 \*\*

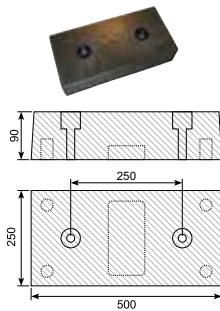

Buffer, vulcanized new rubber.

39.636X \*\*

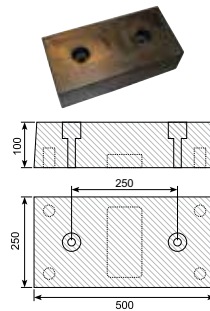

Buffer, vulcanized new rubber.

39.636 \*\*

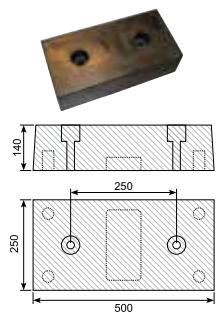

Buffer, vulcanized new rubber with vulcanized steel washers.

39.181061

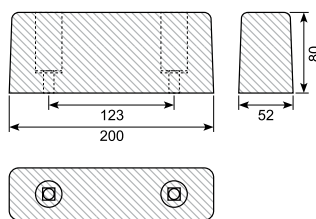

Weight: 1.050 g

39.181052

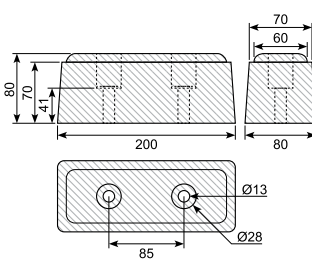

Weight: 1.370 g

39.181060

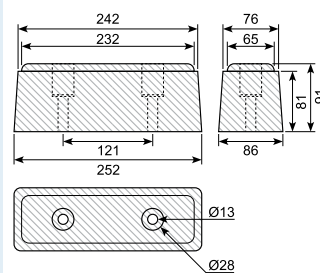

Weight: 1.370 g



Anslagsbuffere / tipper pads \*

Material: Steel / rubber

Art.	Size steel element (mm)	Size rubber element (mm)	Weight (kg)
39.658	150 x 40 x 5	100 x 40 x 25	0,34
39.656	152 x 88 x 6	100 x 86 x 22	0,75
39.657	355 x 75 x 3	290 x 74 x 27	1,35



Anslagsbuffere / tipper pads \*

Material: Aluminium / rubber

Art.	Size aluminium element (mm)	Size rubber element (mm)	Weight (kg)
39.659	152 x 88 x 5	100 x 86 x 23	0,41
39.661	180 x 75 x 5	115 x 75 x 29	0,41
39.660	152 x 88 x 5	100 x 88 x 38	0,6
39.662	180 x 75 x 5	150 x 75 x 40	0,6
39.663	180 x 75 x 4	115 x 75 x 46	0,6
39.664	190 x 115 x 6	120 x 112 x 14 - 20	0,6
39.665	355 x 75 x 5	290 x 75 x 39	1,4



39.180



Material: SBR black  
Hardness: SH 80  
Rubber pad Ø120 for lift stabilizers. Internal Ø108 mm. Height 26 mm.

39.181 \*



Material: SBR black  
Hardness: SH 75  
Rubber pad Ø120 for lift stabilizers. Internal Ø108 mm. Height 26 mm.

39.182 \*



Material: SBR black  
Hardness: SH 75  
Rubber pad Ø145 for lift stabilizers. Internal Ø120 mm. Height 24 mm.

39.183



Material: TPE black  
Hardness: SH 80  
Rubber pad Ø145 for lift stabilizers. Internal height 26 mm.

39.188 \*



Rubber pad for lift stabilizers  
Material: Black SBR  
Hardness: SH 75  
Size: Ø 160 x H 28 mm  
Internal Ø 135 mm

39.183A \*



Rubber pad for lift stabilizers  
Material: Black SBR  
Hardness: SH 80  
Size: Ø 100 x H 21 mm  
Internal Ø 80 mm

39.183B \*



Rubber pad for lift stabilizers  
Material: Black SBR  
Hardness: SH 80  
Size: Ø 140 x H 25 mm  
Internal Ø 103 mm

39.183C \*



Rubber pad for lift stabilizers  
Material: Black  
Hardness: SH 80  
Size: Ø 140 x H 25 mm  
Internal Ø 74 / 60 mm

30.9906

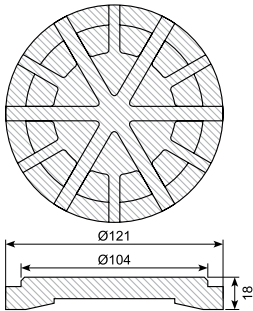

Hardness: SH 80

52.CWC8

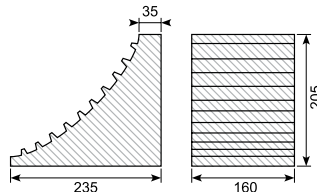

Chocks

39.184



Rubber pad for lift stabilizers  
Material: SBR black  
Hardness: SH 75  
160 x 120 x 20 mm

39.186

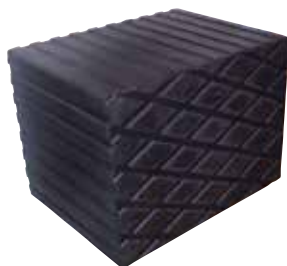

Rubber pad for lift stabilizers  
Material: SBR black  
Hardness: SH 75  
160 x 120 x 120 mm

39.187



Rubber pad for lift stabilizers  
Material: SBR black  
Hardness: SH 75  
180 x 60 x 100 mm

39.185



Rubber pad for lift stabilizers  
Material: SBR black  
Hardness: SH 75  
160 x 120 x 35 mm

# Gummibuffer / Rubber buffer

Art.	Image	Measure
30.13186-1		6,7
30.13186-2		8
30.13186-3		10,5
30.13186-4		10,8
30.13186-5 *		16
30.13186-6 *		21
30.13186-7 *		24,5
30.13186-8 *		31,3

Material: Grey PVC

## 39.645

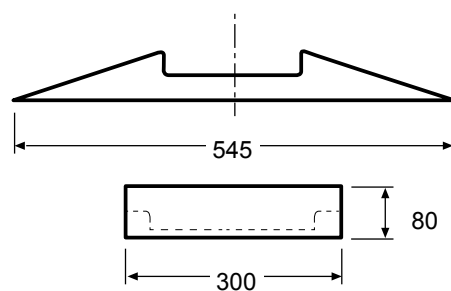
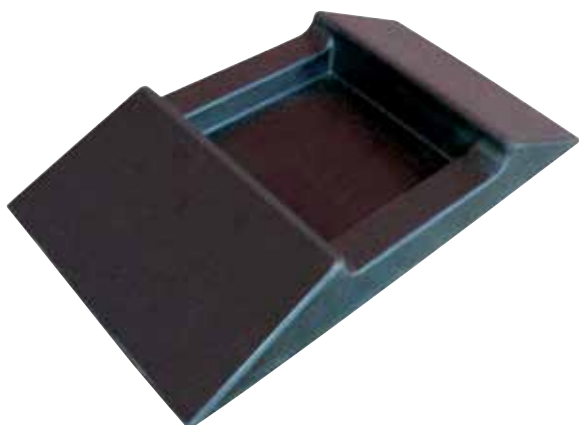

\* Skaffevare / Special order item

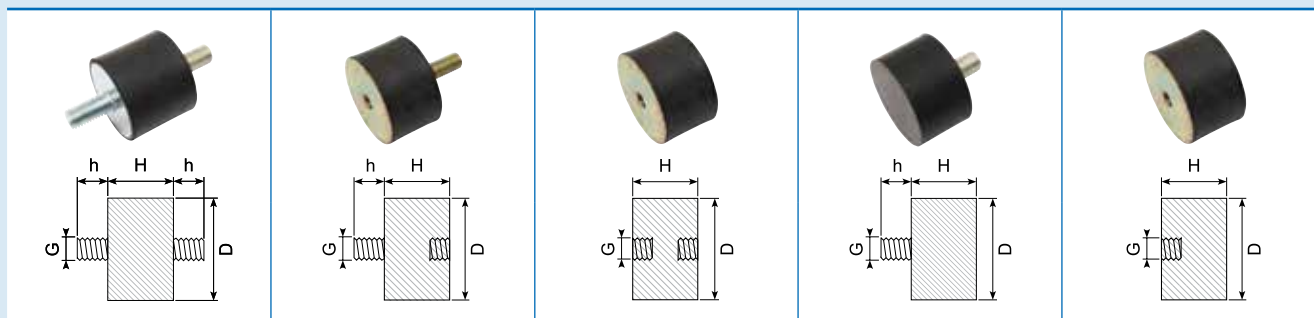

D	H	Type M (1)	Type B (2)	Type C (3)	Type D (4)	Type E (5)
6	7					
8	5					
8	8					
8	10					
9	12					
10	8					
10	10				39.D10/10	
10	15					
10	17					
10	18					
10	30					
11	11					
12	10					
13	26					
15	4					
15	5					
15	6					
15	7					
15	8					
15	9					
15	10				39.D15/10 (M5x15) 39.D15/10-M6 (M6x18)	
15	12					
15	13					
15	15				39.D15/15 (M5x15) 39.D15/15-M6 (M6x15)	
15	20					
15	25					
15	30					
16	18		39.B16/18			
18	10	39.M1810				
20	5					
20	8					
20	10	39.M20/10-M6 (M6x18) 39.M20/10 (M8x18)	39.B20/10-M6 (M6x18) 39.B20/10 (M8x18)	39.C20/10 (M4)		39.E20/10-M6 (M6) 39.E20/10 (M8)
20	11					
20	12					
20	13					
20	15	39.M2015	39.B20/15 (M8x18)		39.D20/15E	
20	17					
20	20	39.M2020 39.M2020-M8	39.B2020	39.C20/20	39.D20/20 (M5x15) 39.D20/20-M6 (M6x18)	
20	23					
20	25					
20	30					
25	8					
25	10			39.C25/10 (M4)		39.E25/10-M6 (M6) 39.E25/10 (M8)
25	12					
25	13		39.B2513			
25	14					

G	h
M6	6, 8, 10, 12, 15, 18, 20, 23, 28
M8	8, 10, 12, 15, 18, 20, 23, 25, 28, 33

G	h
M10	10, 12, 15, 18, 20, 23, 25, 28, 33, 38, 43
M12	10, 12, 18, 20, 23, 25, 27, 33, 37, 42

Fåes i tre hårdheder: Shore 43, 55 og 68.  
Også mulighed for rustfri gevind.  
Available in three hardnesses: SH 43, 55 and 68.  
Also option for stainless threads.

# Vibrationsdæmpere / Vibration muffler

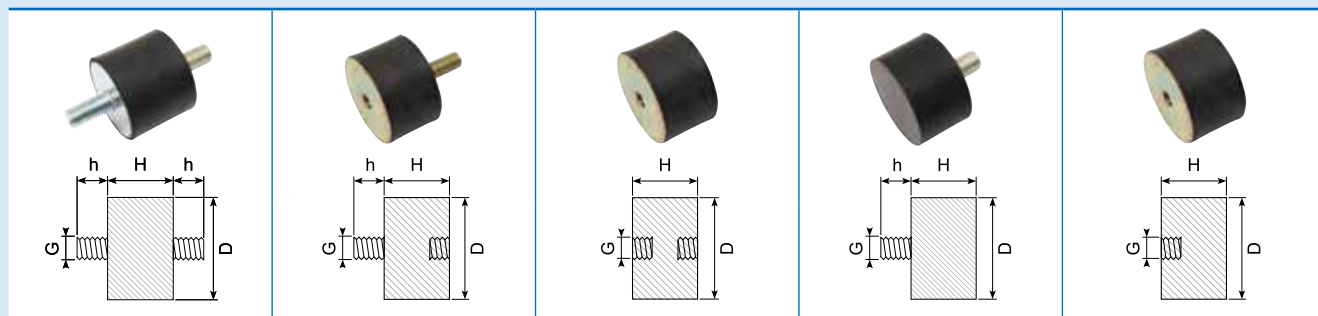

D	H	Type M (1)	Type B (2)	Type C (3)	Type D (4)	Type E (5)
25	15	39.M2515		39.C25/15		
25	17					
25	18					
25	19					
25	20	39.M2520 39.M2520-M6				
25	22					
25	25		39.B25/25 (M8x18) 39.B25/25-M6 (M6x18)	39.C25/25-M6		
25	27					
25	28					
25	30					
26	22					
30	8					
30	10	39.M30/10 (M8x23)			39.D30/10 39.D30/10-M6 (M6x18)	
30	12					
30	13					
30	15	39.M3015-M8x12 39.M3015-M8x15			39.D30/15 39.D30/15-M6 (M6x18)	39.E30/15-M6 (M6) 39.E30/15 (M8)
30	17					
30	18					
30	20	39.M3020 39.M3020-55	39.B30/20 39.B30/20X	39.C30/20 (M8)	39.D30/20 39.D30/20-M6	39.E30/20-M6 (M6) 39.E30/20 (M8)
30	22					
30	25					
30	30	39.M3030 39.M3030-SS	39.B30/30 39.B30/30-M6	39.C30/30	39.D30/30 39.D30/30-M6 (M6x18)	39.E30/30-M6 (M6) 39.E30/30 (M8)
30	35					39.E30/35
30	40					
30	45					
40	10					
40	15				39.D40/15 39.D40/15-M6 (M6x18)	39.E40/15-SH43
40	20	39.M40/20 (M8x23)	39.B40/20 (M8x23)		39.D40/20 (M8x18) 39.D40/20-M6 (M6x18) 39.D40/20-M10 (M10x20) 39.D40/20-A2	39.E40/20-M6 (M6) 39.E40/20 (M8)
40	25	39.4025		39.C40/25 (M8)	39.D40/25-A2	
40	27					
40	28					
40	30	39.M4030	39.B40/30 (M8x23)	39.C40/30	39.D40/30-A2 39.D40/30 39.D40/30-M8 (M8x18)	39.E40/30 (M8)
40	35		39.B40/35 (M8x23)		39.D40/35-A2 39.D40/35 (M10x20)	
40	38	39.M4038		39.C40/40 (M8)		
40	40	39.M40/40 (M10x28)		39.C40/40-M10 (M10)	39.D40/40-A2 39.D40/40 (M10x20)	
40	45				39.D40/45-A2	
40	60					

G	h
M6	6, 8, 10, 12, 15, 18, 20, 23, 28
M8	8, 10, 12, 15, 18, 20, 23, 25, 28, 33

G	h
M10	10, 12, 15, 18, 20, 23, 25, 28, 33, 38, 43
M12	10, 12, 18, 20, 23, 25, 27, 33, 37, 42

Fåes i tre hårdheder: Shore 43, 55 og 68.  
Også mulighed for rustfri gevind.  
Available in three hardnesses: SH 43, 55 and 68.  
Also option for stainless threads.

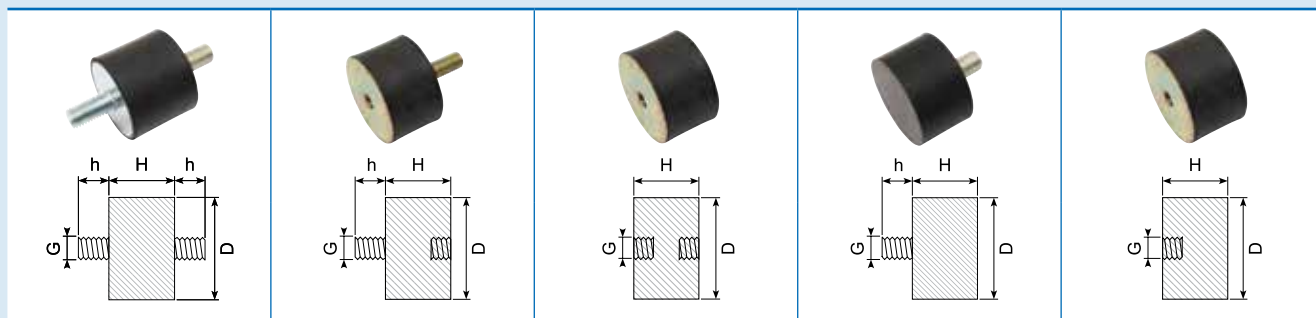

D	H	Type M (1)	Type B (2)	Type C (3)	Type D (4)	Type E (5)
50	7					
50	9					
50	12					
50	15					
50	17					
50	20			39.C50/20 (M10)	39.D50/20 39.D50/20-M12 (M12x23)	39.E50/20 (M8) 39.E50/20-M10 (M10) 39.E50/20-M12 (M12)
50	21		39.B50/21			
50	25	39.M5025		39.C50/25 (M10)	39.D50/25 (M10x20) 39.D50/25-M12 (M12x23)	39.E50/25 (M10) 39.E50/25-M12 (M12)
50	27					
50	28					
50	30	39.M5030	39.B50/30	39.C50/30 39.C50/30-M8 39.C50/30-68 39.C50/35	39.D50/30 39.D50/30-M10 (M10x20)	
50	35					
50	37					
50	40	39.M5040		39.C50/40-M12 39.C50/40		39.E50/40 (M10) 39.E50/40-M12 (M12)
50	42					
50	45	39.M5045		39.C50/45		
50	50	39.M5050	39.B50/50			
50	80		39.B50/50-M10 (M10x28)			
60	15					
60	16					
60	20					
60	25					
60	30		39.B60/30 (M12x25)	39.C60/30-M8 (M8) 39.C60/30 (M10)	39.D60/30 (M10x28) 39.D60/30-M12 (M12x23)	39.E60/30 (M10)
60	35	39.M6035				39.E60/30-M12 (M12)
60	40		39.B60/40	39.C60/40 39.C60/40-M10 SH 43 39.C60/40-M12 SH 43	39.D60/40 (M10x28) 39.D60/40.M12 (M12x23)	39.E60/40 (M10) 39.E60/40-M12 (M12)
60	45					
60	50	39.M6050			39.D6050	
60	60					
65	35			39.C65/35 39.C65/35.M10 (M10)	39.D65/35	
70	20					
70	25					
70	30					
70	35					39.E70/35 (M12)
70	40				39.D70/40 (M10x28) 39.D70/40-M12 (M12x27)	
70	45					
70	50					39.E70/50 (M12)
70	53					
70	55					
70	60					
70	70				39.D70/70	

G	h
M6	6, 8, 10, 12, 15, 18, 20, 23, 28
M8	8, 10, 12, 15, 18, 20, 23, 25, 28, 33

G	h
M10	10, 12, 15, 18, 20, 23, 25, 28, 33, 38, 43
M12	10, 12, 18, 20, 23, 25, 27, 33, 37, 42

Fåes i tre hårdheder: Shore 43, 55 og 68.  
Også mulighed for rustfri gevind.  
Available in three hardnesses: SH 43, 55 and 68.  
Also option for stainless threads.

# Vibrationsdæmpere / Vibration muffler

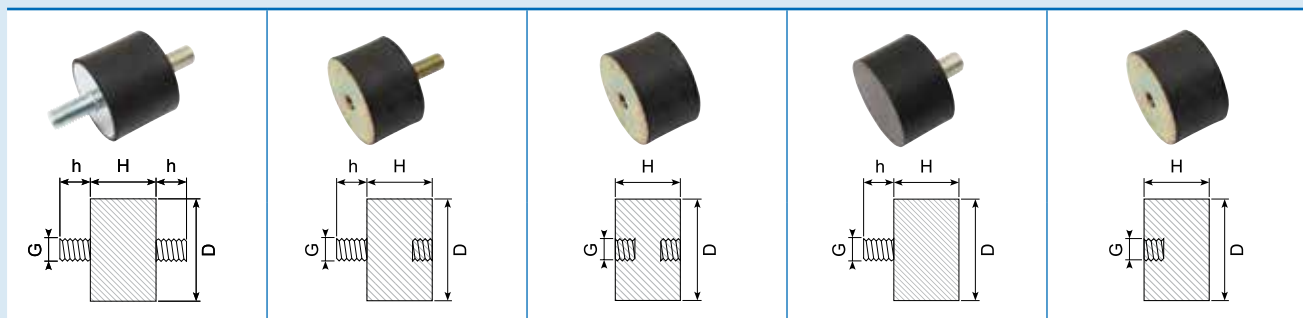

D	H	Type M (1)	Type B (2)	Type C (3)	Type D (4)	Type E (5)
75	20					
75	25					
75	30		39.B75/30 (M12x25)	39.C75/30 (M12) 39.C75/30-M10 (M10)	39.D75/30	39.E75/30 (M10) 39.E75/30-M12 (M12)
75	35					
75	40	39.M7540	39.B75/40 (M12x25)			
75	45			39.C70/45-M10		
75	50	39.M7550	39.B75/50 (M12x25)		39.D75/50-M10 (M10x28)	39.E75/50 (M10) 39.E75/50-M12 (M12)
75	55			39.C75/55 39.C75/55-43 39.C75/55-M10 (M10)		
75	60	39.M7560				
75	70					
75	100			39.C75/100 39.C75/100-M16		
80	17					
80	18					
80	30					
80	40					
80	50	39.M8050				39.E80/50 (M12) 39.E80/50-M16 (M16)
80	55					
80	60					
80	65					
80	70					
80	75					
80	80					
90	60					
100	25					39.E100/25 (M16)
100	30		39.B100/30 (M16x46)		39.D100/30 (M16x41)	39.E100/30 (M16)
100	35					
100	40		39.B100/40 (M16x46)	39.C100/40		39.E100/40 (M16)
100	45					
100	50		39.B100/50 (M16x46)	39.C100/50 (M16)	39.D100/50 (M16x41)	39.E100/50 (M16)
100	55					
100	60					
100	65					
100	70					
100	75		39.B100/75 SH 43	39.C100/75 (M16)	39.D100/75 (M16x41)	39.E100/75 (M16)
100	80					
100	100					
150	40			39.C150/40		
150	50			39.C150/50	39.D150/50 (M16x41)	39.E150/50 (M16) 39.E150/50-M20 (M20)
150	55					
150	60					
150	75			39.C150/75 (M16)		39.E150/75 (M16) 39.E150/75-M20 (M20)
200	100			39.C200/100 (M20)	39.D200/100 (M20x41)	39.E200/100 (M20)

G	h
M6	6, 8, 10, 12, 15, 18, 20, 23, 28
M8	8, 10, 12, 15, 18, 20, 23, 25, 28, 33

G	h
M10	10, 12, 15, 18, 20, 23, 25, 28, 33, 38, 43
M12	10, 12, 18, 20, 23, 25, 27, 33, 37, 42

Fåes i tre hårdheder: Shore 43, 55 og 68.  
Også mulighed for rustfri gevind.  
Available in three hardnesses: SH 43, 55 and 68.  
Also option for stainless threads.

## 39.103195

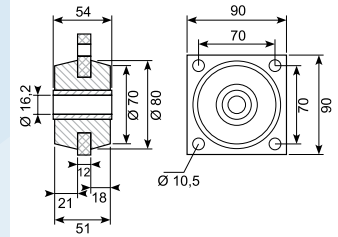
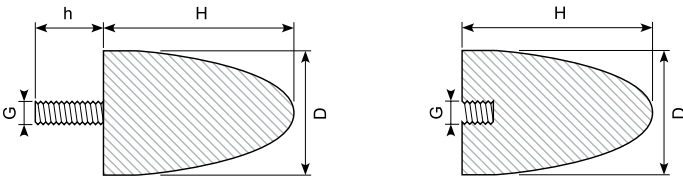

Material: NBR  
Hardness: SH 55

KP-D-no.	KP-E-no.	D/H	D	H	G	h
39.KP-D10/10	39.KP-E10/10	10/10	10	10	M5	12
39.KP-D15/22	39.KP-E15/22	15/22	15	22	M6	18
39.KP-D20/15	39.KP-E20/15	20/15	20	15	M6	10
39.AV2024	39.KP-E20/24	20/24	20	24	M6	18
39.KP-D25/16	39.KP-E25/16	25/16	25	16	M6	18
39.KD25/17		25/17	25	17	M6	8
39.KP-D25/20	39.KP-E25/20	25/20	25	20	M6	18
39.KP-D30/30	39.KP-E30/30	30/30	30	30	M8	20
39.KP-D30/36	39.KP-E30/36	30/36	30	36	M8	20
39.AV30		30/40	30	40	M8	23
	39.KP-E35/40	35/40	35	40	M8	23
39.KD50/18		50/18	50	18	M10	18
39.KP-D50/50 **	39.KP-E50/50	50/50	50	50	M10	28
39.AV50		50/55	50	55	M10	27
39.KP-D50/58		50/58	50	58	M10	28
39.KP-D50/61	39.KP-E50/61	50/61	50	61	M8	28
39.KP-D50/67	39.KP-E50/67	50/67	50	67	M8	33
39.AV5068	39.KP-E50/68	50/68	50	68	M10	38
39.KP-D60/40	39.KP-E60/40	60/40	60	40	M10	28
39.KP-D70/58	39.KP-E70/58	70/58	70	58	M12	32
39.KP-D70/60	39.KP-E70/60	70/60	70	60	M12	37
39.KP-D75/89	39.KP-E75/89	75/89	75	89	M12	37
39.AV9580	39.KP-E95/80	95/80	95	80	M16	41
39.KP-D115/136	39.KP-E115/136	115/136	115	136	M16	41
39.KP-D118/77	39.KP-E118/77	118/77	118	77	M16	41

### Skaffevarer / Special order item



# Fendere / Fenders

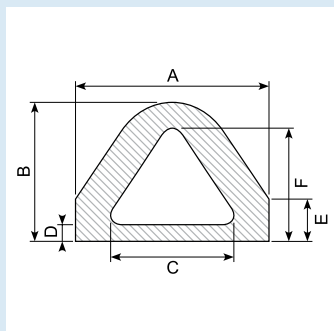

Material: Black EPDM  
 Hardness: SH 70  
 Fenders for harbours, loading ramps w. m.

Art.	A	B	C	D	E	F	Kg/m
39.3872	40	25	28	5	10	20	0,57
39.3873 *	55	40	38	8	15	32	1,39
39.3875 *	60	50	40	10	20	42	1,75
39.4087 *	60	52	30	11	11	43	2
39.3876	80	65	50	12	25	39	3,2
39.3887 *	80	70	40	15	0	68	3,5
39.4333 *	80	70	54	15	16	59	4
39.2486 *	82	67	42	15	15	57	3,5
39.4156 *	109	117	50	42	50	95	10,5
39.3846 *	110	95	50	22	18	76	6,1
39.3874 *	110	95	70	15	30	80	5,79
39.4399 *	110	130	70	20	45	110	7,8
39.3010 *	120	110	70	14	35	95	7,39
39.3868 *	150	130	100	20	40	110	10,82
39.4178 *	150	160	105	50	60	130	16,3
39.3722 *	160	138	92	33	0	105	15,83
39.3240 *	170	130	110	15	45	110	10,5

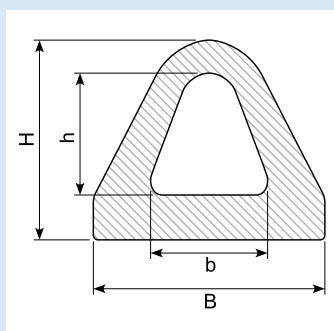

Material: Black EPDM  
 Hardness: SH 70  
 Fenders for vans harbours, loading ramps etc.

Art.	B	H	b	h	L	Kg/m
39.674	40	22			20 m	0,715
39.678	60	50			10 m	2,1
39.678X *	50	60			20 m	2,1
39.680X **	84	70	46	41	20 m	3,7
39.684X	110	95			10 m	7,076
39.684XS *						
39.685 *	120	120			3 m	11,204

Soft. SH 45. Min. order: 40 m

Material: White

Art.	B	H	L	Min. order
39.680H *				100 m
39.680H-1180	84	70	1.180 mm	

## 39.4380X

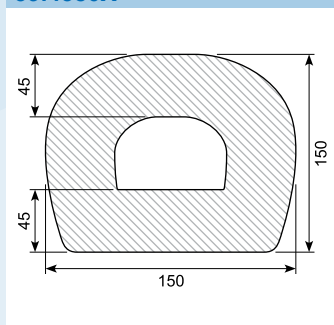

Material: NR / SBR  
 Length: 2 m

## 39.3803X

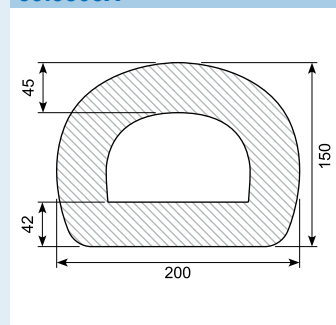

Material: NR / SBR  
 Length: 2 m

## 39.3904X

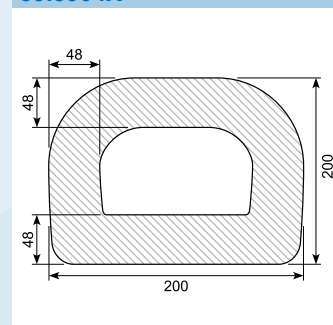

Material: NR / SBR  
 Length: 2 m



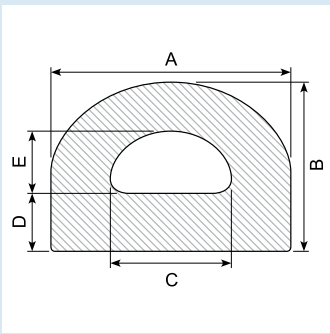

Material: Black EPDM  
 Hardness: SH 70  
 Fenders for harbours, loading ramps w. m.

Art.	A	B	C	D	E	Kg/m
39.3581	30	25	11	7,5	11	0,67
39.36412 *	40	75	23	32	23	3,76
39.2776 *	51	45	20	10	20	2,08
39.3428 *	65	70	35	18	28	2,99
39.3029 *	80	80	40	25	35	5,54
39.3700 *	80	78	56	12	54	3,55
39.3925 *	80	80	40	23	40	5,59
39.4229 *	80	70	46	25	20	4,57
39.4110 *	95	100	38	30	45	5,4
39.3051 *	100	80	50	25	30	7,05
39.3802	100	80	80	12	56	3,68
39.3923 *	100	95	44	29	40	8,1
39.3952 *	100	95	60	20	50	6,99
39.4251 *	100	60	50	20	20	5,81
39.4403 *	100	95	60	28	42	6,27
39.4310 *	107	67	40	22	20	6,4
39.3726 *	110	110	50	30	25	12,14
39.3878 *	120	70	30	20	30	6,41
39.93 *	120	120	70	44	51	11,84
39.4381 *	125	100	65	33	37	10,87
39.69 *	130	150	50	50	50	21,05
39.4257 *	130	145	40	55	40	17,24
39.3813 *	140	125	85	35	55	14,75
39.3815 *	140	80	60	20	36	10,27
39.3381 *	150	150	85	30	85	18,81
39.4129 *	150	130	50	55	50	20
39.4224 *	150	150	92	29	92	14,7
39.4244 *	150	180	45	87	40	27,8
39.4380	150	150	80	40	75	18,22
39.3366 *	160	125	90	25	65	15,82
39.4311 *	160	175	68	79	68	17,1
39.57 *	200	165	40,5	80	40,5	31,44
39.3023 *	190	195	21	89	21	40,57
39.4012 *	190	195	55	89	55	37,7
39.3803 *	200	150	148	14	113	11,81
39.4249 *	200	220	75	82	75	42,39
39.4250 *	200	220	100	38	80	39,38
39.4269 *	200	220	75	82	75	36,85
39.3849 *	240	260	110	90	110	54,54
39.3879 *	250	290	120	60	110	48,96
39.56 *	250	200	136	50	100	39,84
39.4054 *	280	190	180	50	90	38,5
39.79 *	300	254	150	75	104	68,25
39.55 *	350	350	220	80	165	97,68

## D-fender

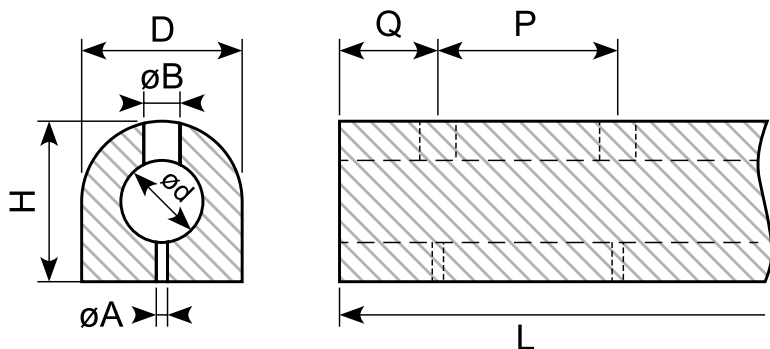

Art.	H	D	A	B	d	Q	P	L
39.200200 *	200	200	25	60	100	150	300	1.500
39.300300 *	300	300	29	65	150	150	300	1.500

## D-fender

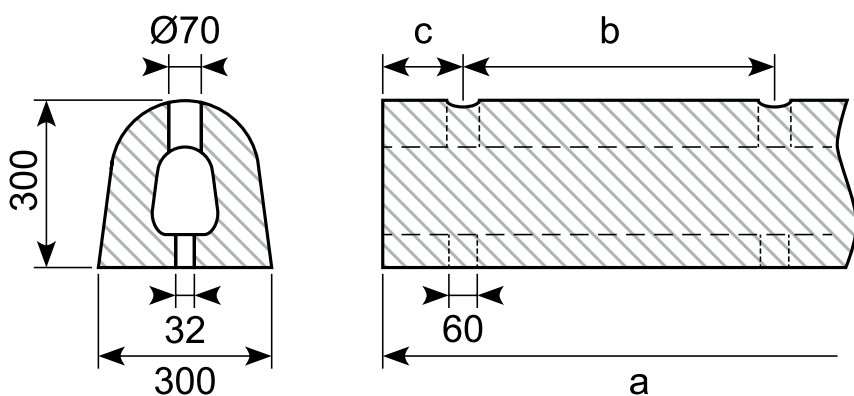

Art.	Size	a (mm)	b (mm)	c (mm)	Mounting holes	Weight
*	D300HX900L-2h	900	600	150	2	62
*	D300HX1000L-2h	1.000	600	250	2	69
*	D300HX1500L-3h	1.500	600	150	3	103
39.300300A *	D300HX1500L-5h	1.500	320	110	5	103
*	D300HX1500-5h-S	1.500	320	110	5	98
*	D300HX2000-4h	2.000	500	250	4	210

## 39.500500A \*

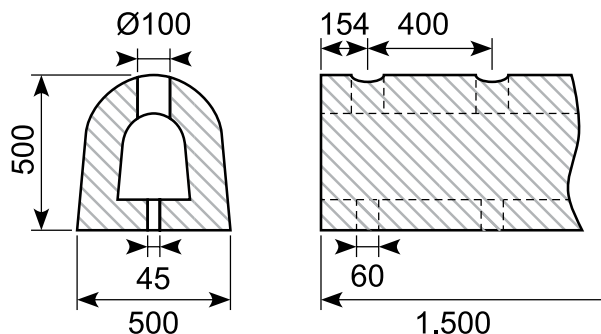

## D-fender

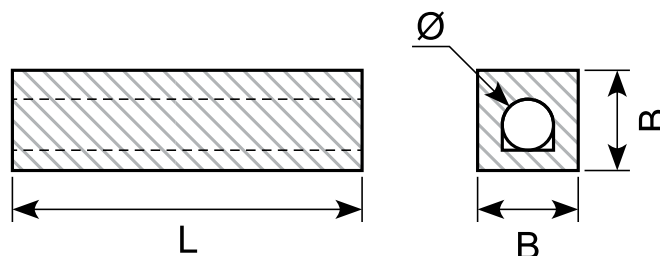

Art.	B (mm)	Ø (mm)
*	150	75
*	200	100
*	250	125
39.300300FK *	300	150
*	400	200
*	500	250

Længder fra 500 - 3.000 mm /  
Lengths from 500 - 3.000 mm

DD-fender

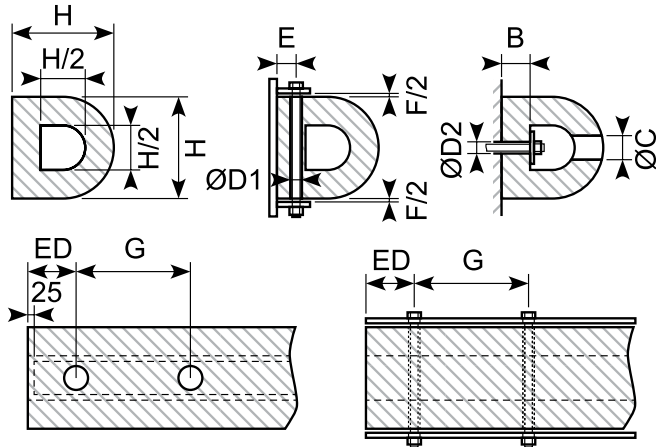

Art.	H (mm)	B (mm)	C (mm)	D1 (mm)	D2 (mm)	F (mm)	G (mm)	ED (mm)	Flat bar (mm)	Anchors	Weight (kg/m)
*	100 x 100	25	30	18	24	10	200-300	90-130	40 x 5	M12	8,3
*	150 x 150	37,5	40	24	32	12	250-350	110-150	60 x 8	M16	18
*	200 x 200	50	50	30	40	15	300-400	130-180	80 x 10	M20	32
*	250 x 250	62,5	60	36	48	20	350-450	140-200	90 x 12	M24	50
<b>39.DD300300</b> *	300 x 300	75	60	36	48	25	350-450	140-200	110 x 12	M24	72
*	350 x 350	87,5	75	45	60	25	350-450	140-200	130 x 15	M30	103,6
*	380 x 380	95	75	45	60	30	350-450	140-200	140 x 15	M30	122,1
*	400 x 400	100	75	45	60	30	350-450	140-200	150 x 15	M30	128
*	500 x 500	125	90	54	72	40	400-500	160-230	180 x 20	M36	200

SD-fender

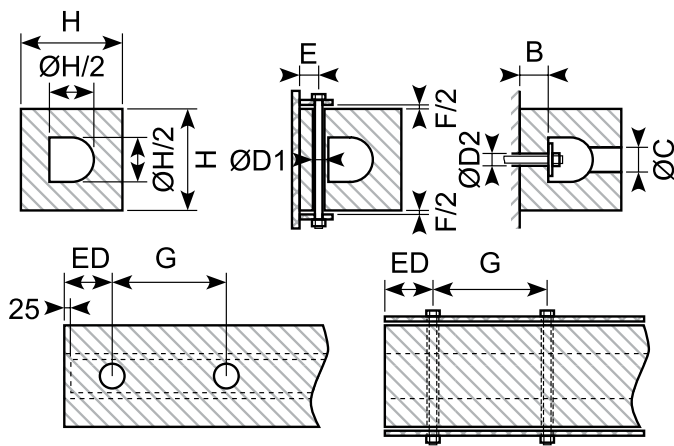

Art.	H (mm)	B (mm)	C (mm)	D1 (mm)	D2 (mm)	E (mm)	F (mm)	G (mm)	ED (mm)	Flat bar (mm)	Anchors	Weight (kg/m)
*	100 x 100	25	30	18	24	25	10	200-300	90-130	40 x 5	M12	9,5
*	150 x 150	37,5	40	24	32	30	12	250-350	110-150	50 x 8	M16	22,1
*	200 x 200	50	50	30	40	45	15	300-400	130-180	70 x 10	M20	38,7
<b>39.SD300250</b> *	250 x 250	62,5	60	36	48	50	20	350-450	140-200	90 x 12	M24	59,3
<b>39.SD300300</b> *	300 x 300	62,5	60	36	48	50	25	350-450	140-200	100 x 12	M24	73
*	350 x 350	75	75	45	60	60	25	350-450	140-200	100 x 15	M30	89,3
*	400 x 400	100	75	45	60	80	30	350-450	140-200	150 x 15	M30	148,5
*	500 x 500	125	90	54	72	90	40	400-500	160-230	180 x 20	M36	232,1

## DC-fender

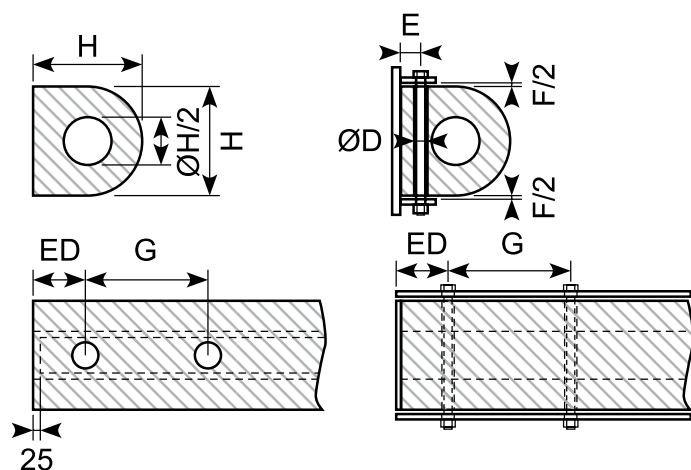

Art.	H (mm)	D (mm)	E (mm)	F (mm)	G (mm)	ED (mm)	Anchors	Weight (kg/m)
* 100 x 100	100	18	25	10	200-300	90-130	M12	9,9
* 150 x 150	150	24	30	12	250-350	110-150	M16	20
* 200 x 200	200	30	45	15	300-400	130-180	M20	37,4
* 250 x 250	250	36	50	20	350-450	140-200	M24	57,2
<b>39.DC300300</b> *	300	36	60	25	350-450	140-200	M24	81,3
* 350 x 350	350	45	70	25	350-450	140-200	M30	109,5
* 400 x 400	400	45	80	30	350-450	140-200	M30	142
* 500 x 500	500	54	90	40	400-500	150-230	M36	208

## SC-fender

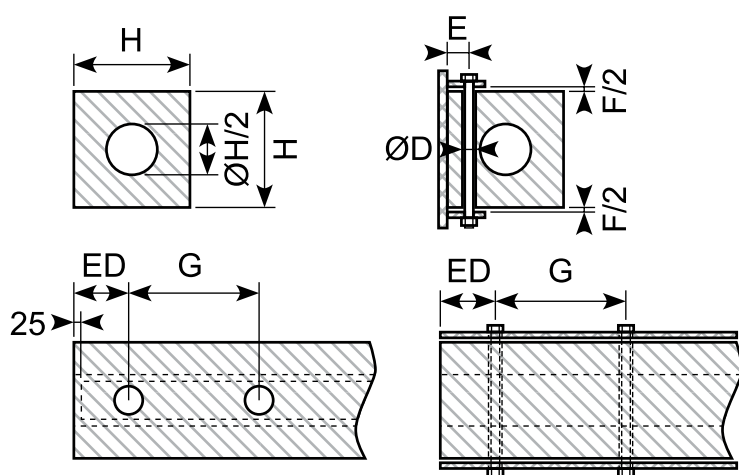

Art.	H (mm)	D (mm)	E (mm)	F (mm)	G (mm)	ED (mm)	Anchors	Weight (kg/m)
* 100 x 100	100	18	25	10	200-300	90-130	M12	11,1
* 150 x 150	150	24	30	12	250-350	110-150	M16	22,9
* 200 x 200	200	30	45	15	300-400	130-180	M20	42,6
* 250 x 250	250	36	50	20	350-450	140-200	M24	65,3
<b>39.SC300300</b> *	300	36	60	25	350-450	140-200	M24	92,9
* 350 x 350	350	45	70	25	350-450	140-200	M30	117,6
* 400 x 400	400	45	80	30	350-450	140-200	M30	153,6
* 500 x 500	500	54	90	40	400-500	150-230	M36	240,1

Keyhole fender \*

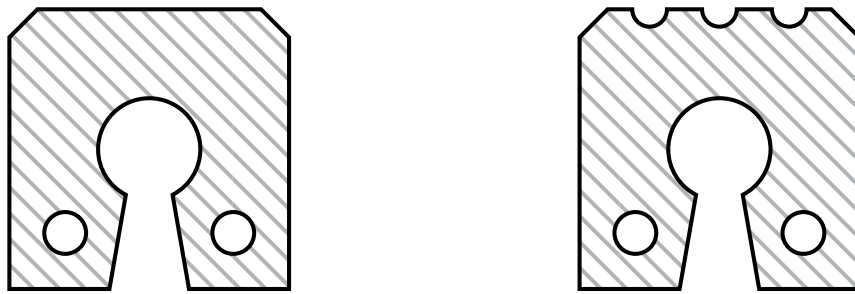

Wing-type-fender \*

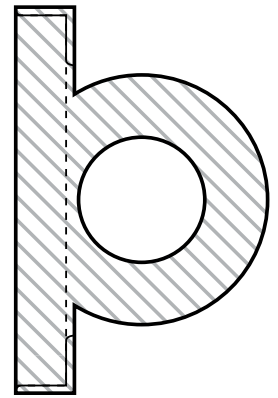

MC-fender \*

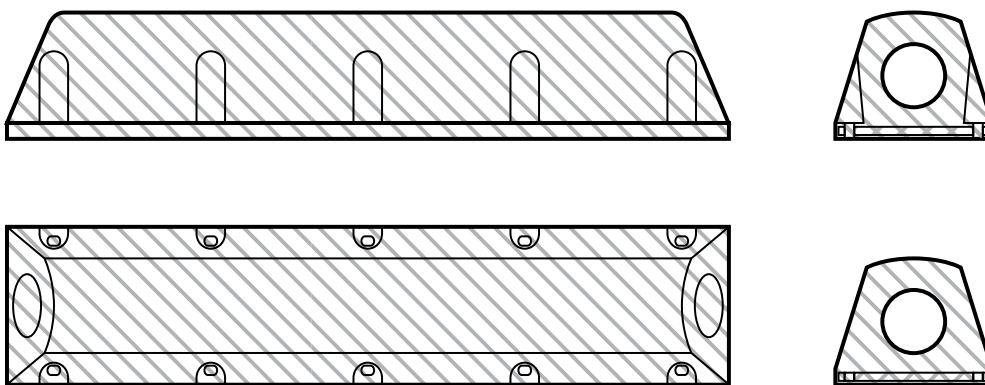

KF-A-fender

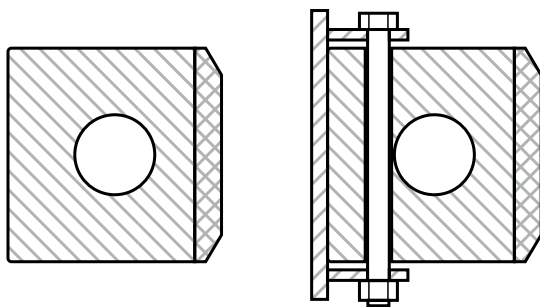

KF-B-fender \*

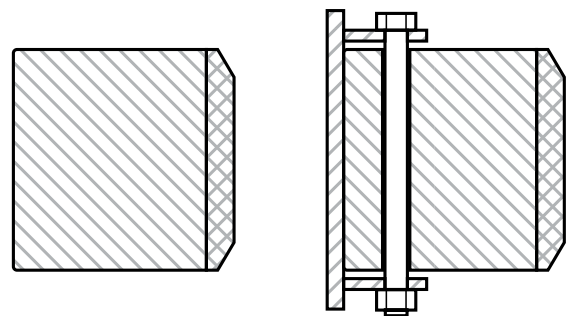

KF-C-fender \*

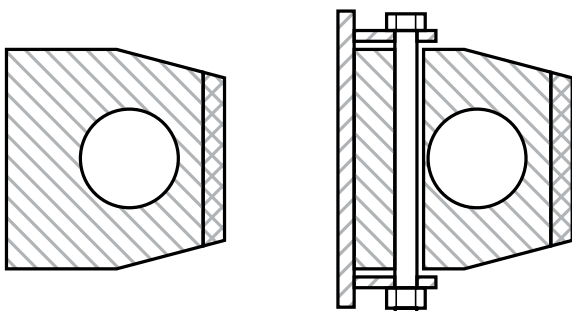

KF-D-fender \*

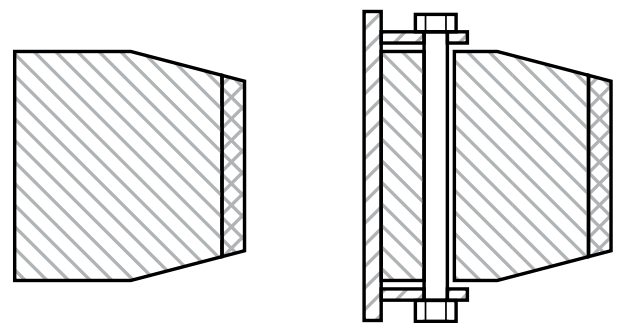

## Børste- og flock-lister / Brush sections

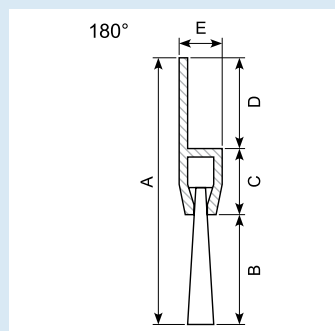

Art.	Type	A mm	B mm	C mm	D mm	E mm	L m
57.400/1 *	A	27	10,3	5,3	11,4	5,2	1
57.400/2	A	27	10,3	5,3	11,4	5,2	2
57.400/3 *	A	27	10,3	5,3	11,4	5,2	3
57.401/1	B	31	13,5	6,7	10,8	6,5	1
57.401/2 *	B	31	13,5	6,7	10,8	6,5	2
57.401/3 *	B	31	13,5	6,7	10,8	6,5	3
57.402/1 *	C	34	15	8,4	10,6	7,7	1
57.402/2	C	34	15	8,4	10,6	7,7	2
57.402/3 *	C	34	15	8,4	10,6	7,7	3
57.403/1 *	D	51,8	23,8	10,8	17,2	10	1
57.403/2 *	D	51,8	23,8	10,8	17,2	10	2
57.403/3 *	D	51,8	23,8	10,8	17,2	10	3
57.404/1 *	E	71	41	11,5	18,5	10,3	1
57.404/2	E	71	41	11,5	18,5	10,3	2
57.404/3	E	71	41	11,5	18,5	10,3	3
57.405/1 *	GS	78,5	44,5	14,5	19,5	13,5	1
57.405/2 *	GS	78,5	44,5	14,5	19,5	13,5	2
57.405/3 *	GS	78,5	44,5	14,5	19,5	13,5	3
57.406/1 *	GM	98,3	64,3	14,5	19,5	13,5	1
57.406/2 *	GM	98,3	64,3	14,5	19,5	13,5	2
57.406/3	GM	98,3	64,3	14,5	19,5	13,5	3
57.407/1 *	GL	135,6	101,6	14,5	19,5	13,5	1
57.407/2 *	GL	135,6	101,6	14,5	19,5	13,5	2
57.407/3 *	GL	135,6	101,6	14,5	19,5	13,5	3

57.401/3BX Brushes for 57.401. 3 m lengths.

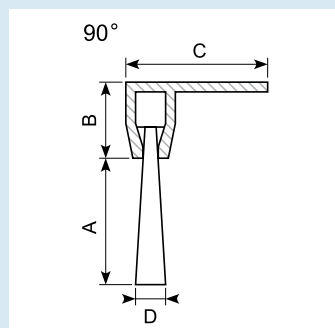

Art.	Type	A mm	B mm	C mm	D mm	L m
57.440/1 *	A	10,3	5,3	14	5,2	1
57.440/2 *	A	10,3	5,3	14	5,2	2
57.440/3 *	A	10,3	5,3	14	5,2	3
57.441/1 *	B	13,5	6,7	17,5	6,5	1
57.441/2 *	B	13,5	6,7	17,5	6,5	2
57.441/3 *	B	13,5	6,7	17,5	6,5	3
57.442/1 *	C	15	8,4	22	8,1	1
57.442/2	C	15	8,4	22	8,1	2
57.442/3 *	C	15	8,4	22	8,1	3
57.443/1 *	D	23,8	10,8	27	10	1
57.443/2 *	D	23,8	10,8	27	10	2
57.443/3 *	D	23,8	10,8	27	10	3
57.444/1 *	E	41	11,5	29	10,3	1
57.444/2 *	E	41	11,5	29	10,3	2
57.444/3 *	E	41	11,5	29	10,3	3
57.445/1 *	GS	44,5	14,5	35	13,5	1
57.445/2 *	GS	44,5	14,5	35	13,5	2
57.445/3 *	GS	44,5	14,5	35	13,5	3
57.446/1 *	GM	64,3	14,5	35	13,5	1
57.446/2	GM	64,3	14,5	35	13,5	2
57.446/3 *	GM	64,3	14,5	35	13,5	3
57.447/1 *	GL	101,6	14,5	35	13,5	1
57.447/2	GL	101,6	14,5	35	13,5	2
57.447/3 *	GL	101,6	14,5	35	13,5	3

**57.403/2.5J**

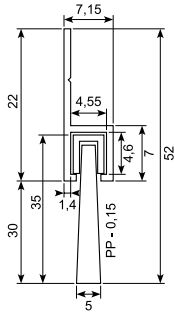

Material: Aluminium with polypropylene brush  
Length: 2,5 m

**57.405/2J**

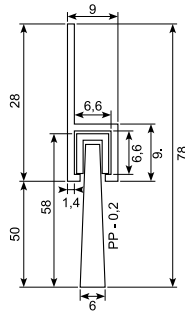

Material: Aluminium with polypropylene brush  
Length: 2 m

**57.443/2JP**

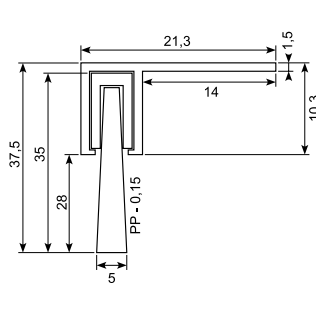

Material: Plastic with polypropylene brush  
Length: 2 m

**33.621**

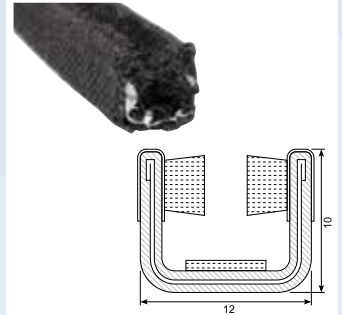

Rubber / fabric / brush  
4 - 5 mm glass  
Steel

**33.623**

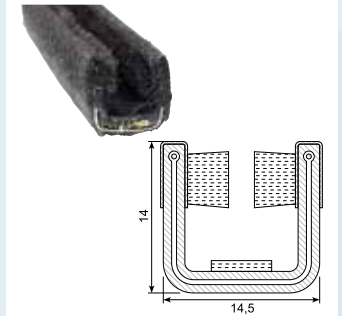

Rubber / fabric / brush  
4 - 6 mm glass  
Steel

**33.611**

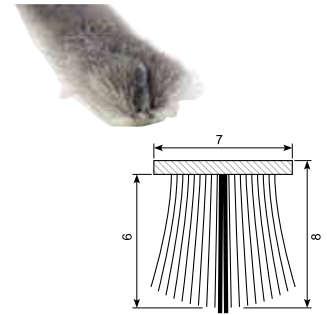

Self-adhesive list with brushes and waterproof center film

**33.615**

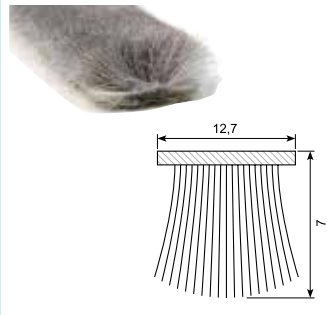

Self-adhesive list with brushes.

**33.613**

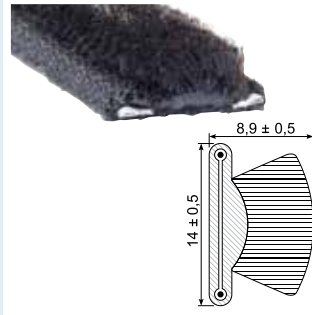

**33.670**

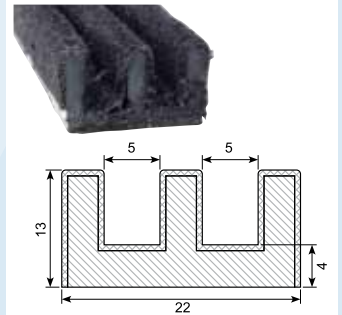

Flocked channel molding

**33.671\***

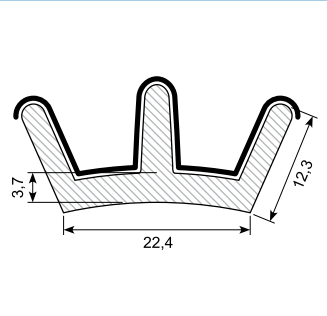

Material: EPDM  
Density: 1,28  
Hardness: SH 70  
Min. order: 2.000 m  
Flock: 3,3 dtex

**33.672\***

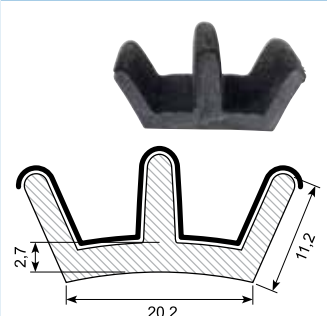

Material: EPDM  
Density: 1,28  
Hardness: SH 70  
Min. order: 2.000 m  
Flock: 3,3 dtex

**33.673\***

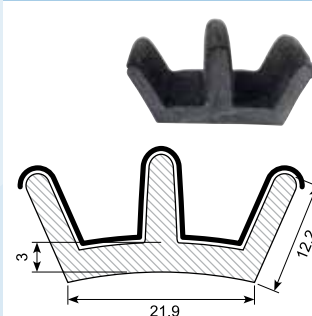

Material: EPDM  
Density: 1,28  
Hardness: SH 70  
Min. order: 2.000 m  
Flock: 3,3 dtex

## Børste- og flock-lister / Brush sections

33.674 \*

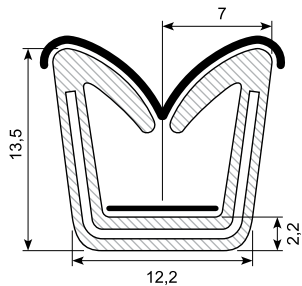

Material: EPDM  
Density: 1,28  
Hardness: SH 70  
Min. order: 3.000 m  
Flock: 3,3 dtex

33.675 \*

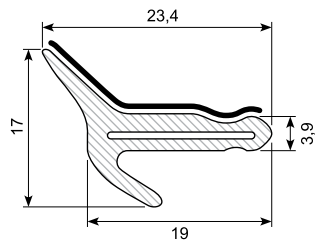

Material: EPDM  
Density: 1,28  
Hardness: SH 70  
Min. order: 3.000 m  
Flock: 3,3 dtex

33.676 \*

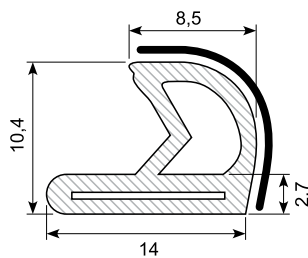

Material: EPDM  
Density: 1,28  
Hardness: SH 70  
Min. order: 3.000 m  
Flock: 3,3 dtex

30.13066 \*

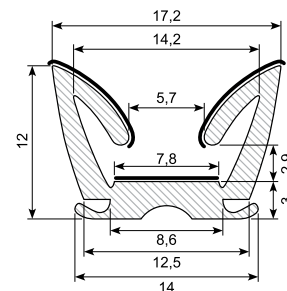

Material: EPDM  
Density: 1,28  
Hardness: SH 70  
Min. order: 3.000 m  
Flock: 3,3 dtex  
Glass width: 5 mm

33.624 \*

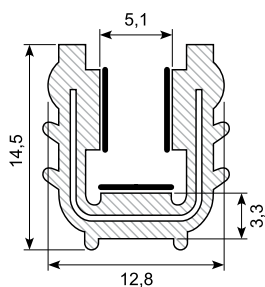

Material: EPDM  
Density: 1,28  
Hardness: SH 70  
Min. order: 3.000 m  
Flock: 3,3 dtex

33.625 \*

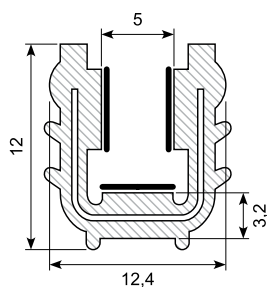

Material: EPDM  
Density: 1,28  
Hardness: SH 70  
Min. order: 3.000 m  
Flock: 3,3 dtex

30.14803 \*

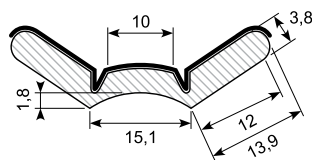

Material: EPDM  
Density: 1,28  
Hardness: SH 70  
Min. order: 3.000 m  
Flock: 3,3 dtex

33.416

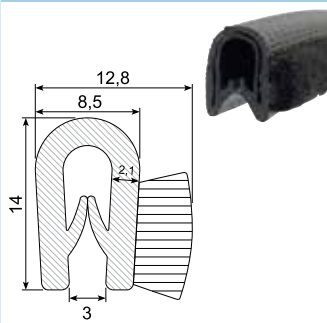

Edge trim: PVC with brush  
Grip range: 1 - 2,5 mm  
Hardness: SH 78  
Insert: 25 x 0,48 mm steel  
New brush



## Lydabsorption / Sound absorption

### Selvklebende skum med Tedlarbelægning

Benyttes, alt afhængig af folieafdækning i førerkabiner, motorrum, kompressorer, generatorer, ventilatorer, turbiner, pumper og lignende.

### Self-adhesive foam with Tedlar coat

Depending on the foil covers this is used in cabs, engine compartment, compressors, generators, fans, turbines, pumps or the like.

Art.	Farve / Color	Overflade / Surface	Dimension (mm)
48.603	Hvid / White	Plan 100% Plane 100%	20 x 1.200 x 1.500
48.604	Hvid / White	Plan 100% Plane 100%	30 x 1.200 x 1.500

### Selvklebende skum med Bitumenindlæg

Self-adhesive foam with Bitumen inserts

Art.	Farve / Color	Overflade / Surface	Dimension (mm)
48.613K	Hvid / White	Plan 100% Plane 100%	33 x 600 x 1.000

## Lydisolering / Soundproofing

Lydisoleringsmaterialer er typisk lavet af åbencellede, fleksible skummaterialer i tungere densiteter. Den forøgede densitet er opnået ved at anvende regenereret skum.

Anvendelsesområdet kan typisk være lydisolering af motorrum i lystbåde, vindmøllehuse, kompressorer og andre støjende maskiner, hvor det er muligt at adskille støjkilden fra det omliggende område.

Da der ofte skal etableres et kølende luftskifte i disse situationer, laver man en lydsluse beklædt med lydabsorptionsmateriale.

Granulat koldskum med enestående lydæmpningsevne. Benyttes til beklædning af motorrum, maskinafskærmninger, ventilationskamre og støjkabiner. Grundet den lave densitet kan den også, med fordel, anvendes som absorbent.



Art.	Overflade / Surface	Dimension (mm)
48.634	Ingen / None	20 x 500 x 1.000
48.635	Ingen / None	30 x 500 x 1.000
48.636	Ingen / None	40 x 500 x 1.000



Art.	Overflade / Surface	Dimension (mm)
48.634F	Folie / Foil	20 x 500 x 1.000
48.635F	Folie / Foil	30 x 500 x 1.000
48.636F	Folie / Foil	40 x 500 x 1.000
48.636FX	Folie / Foil	40 x 1.000 x 2.000

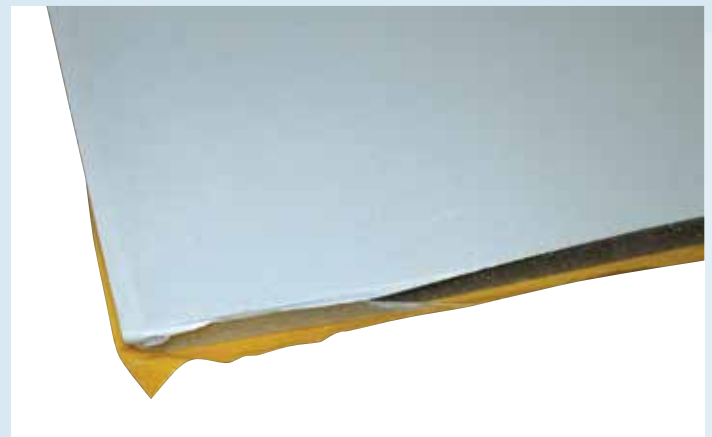

### Self-adhesive foam with rubber surface

Selvklebende skum med gummi-overflade

Art.	Farve / Color	Overflade / Surface	Dimension (mm)
48.626	Sort / Black	Plan 100% Plane 100%	2 / 10 x 1.200 x 1.500

Soundproofing materials are typically made of open-celled, flexible foam materials in heavier densities. The increased density is achieved by using regenerated foam.

The field of application can typically be soundproofing of the engine compartment in yachting, wind turbine housings, compressors and other noisy machines where it is possible to separate the noise source from the surrounding area.

Because it is often necessary to assure a cooling air circulation in these situations you make a sound lock covered with soundproofing material.

Granulate cold foam with unique soundproofing ability. This is used for coating of engine compartment, machine guards, ventilation chambers and noise cabins. Due to the low density it may also be used as absorbent with advantage.



Art.	Overflade / Surface	Dimension (mm)
48.634K	Klæb / Glue	20 x 500 x 1.000
48.635K	Klæb / Glue	30 x 500 x 1.000
48.636K	Klæb / Glue	40 x 500 x 1.000



Art.	Overflade / Surface	Dimension (mm)
48.634KF	Folie og klæb / Foil and glue	20 x 500 x 1.000
48.635KF	Folie og klæb / Foil and glue	30 x 500 x 1.000
48.636KF	Folie og klæb / Foil and glue	40 x 500 x 1.000

## Lydisolering / Soundproofing

### Lydabsorption / Sound absorption

Lydabsorptionsmaterialer (PU) er typisk lavet af åbencellede, fleksible skummaterialer i lettere densiteter.

Anvendelsesområdet vil typisk være indvendig beklædning af førerkabiner, støjskærme, lydsluger, kanalvægge og lignende situationer, hvor det ikke er muligt at adskille støj-kilden fra det omkringliggende område.

Soundproofing materials (PU) are typically made of open-celled, flexible foam materials in lighter densities.

The field of application will typically be interior sheathing of cabs, noise barriers, sound locks, canal walls and similar situations where it is not possible to separate the noise source from the surrounding area.

#### Selvklæbende skum uden folie

Anvendes til indvendig beklædning af motorrum, maskin-fæstmønstre, støjkabiner, el-styretavler, paneler, indlæg i emballage m.m.

#### Self-adhesive foam without foil

This is used for interior sheathing of engine compartment, machine guards, noise cabins, electrical control panels, panels and inserts in packaging with more.

#### Selvklæbende skum med PVC-folie

Benyttes, alt afhængig af folieafdækning, til beklædning i førerkabiner, motorrum, kompressorer, generatorer, ventilatorer, turbiner, pumper og lignende.

Self-adhesive foam with PVC foil Depending on the foil covers this is used for sheathing in cabs, engine compartment, compressors, generators, fans, turbines, pumps or the like.



Art.	Overflade / Surface	Dimension (mm)
48.621	Plan / Plane	10 x 1.200 x 1.500
48.622	Plan / Plane	20 x 1.200 x 1.500
48.622X	Plan / Plane	30 x 1.200 x 1.500

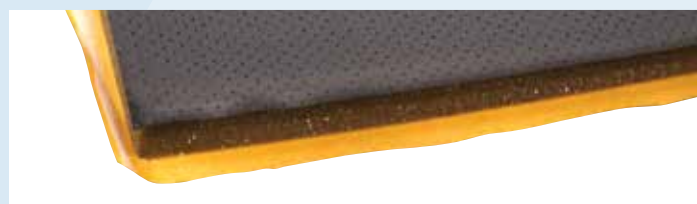

Art.	Farve / Color	Overflade / Surface	Dimension (mm)
48.605X	Sort / Black	2% perforated	10 x 1.200 x 1.500
48.605	Sort / Black	2% perforated	20 x 1.200 x 1.500
48.605Y	Sort / Black	2% perforated	30 x 1.200 x 1.500

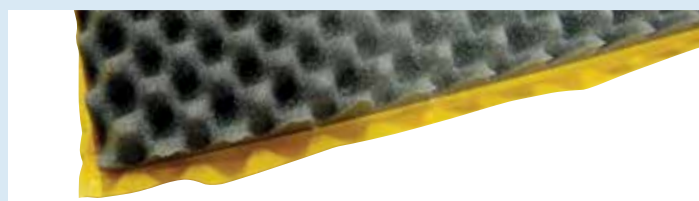

Art.	Overflade / Surface	Dimension (mm)
48.623	Æggebakke / Egg tray	30 / 15 x 1200 x 1500
48.624	Æggebakke / Egg tray	40 / 20 x 1200 x 1500
48.623X	Æggebakke / Egg tray	30 / 15 x 1.200 x 2.000

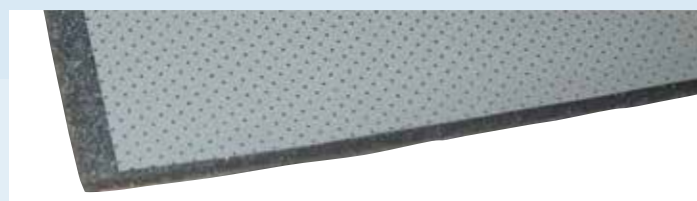

Art.	Farve / Color	Overflade / Surface	Dimension (mm)
48.451	Grå / Grey	2 % perf. / pap 2 % perf. / cardboard	10 x 1.000 x 1.500
48.452	Grå / Grey	2 % perf. / pap 2 % perf. / cardboard	20 x 1.000 x 1.500

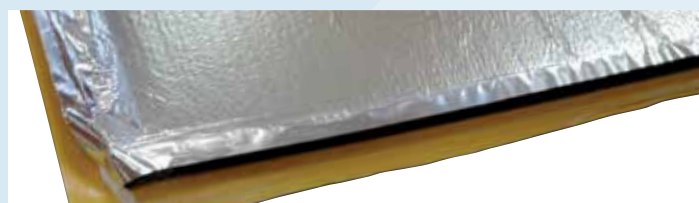

Art.	Color	Surface	Dimension (mm)
48.608	Alu.	Plane 100%	20 x 1.200 x 1.500
48.609	Alu.	Plane 100%	30 x 1.200 x 1.500



Art.	Color	Surface	Dimension (mm)
48.605B *	Brown	2 % perforated	20 x 1.200 x 1.500

Min. order: 10 pcs.

## Soundproofing / Lyddæmpning

Lyddæmpningsmaterialer er typisk lavet af hårdt og tungt materiale.

Anvendelsesmulighederne kan typisk være dæmpning af store pladearealer, bundplader i biler/maskiner, dørsider og andre steder hvor der kan opstå resonans.

Soundproofing materials are typically made of hard and heavy material.

The field of application can typically be damping of large plate areas, bottom plates in cars / machinery, doors and other places where there may be resonance.

Bitumenplader er kunststofbasis

Bitumen plates are based on synthetic material

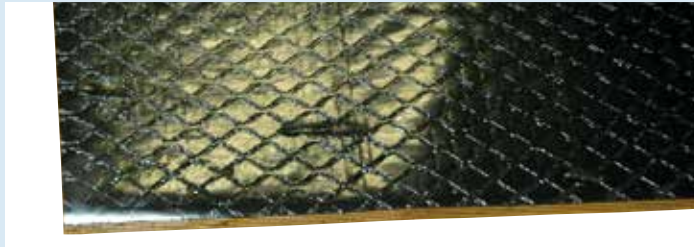

Art.	Surface	Pack	Dimension (mm)
48.544A	Adhesive	4 pk.	500 x 500 x 3
48.542	Adhesive	6 pk.	500 x 250



Art.	Surface	Pack	Thickness (mm)	Dimension (mm)
48.442	Adhesive	1 pc	1,7	500 x 1.050



Art.	Surface	Pack	Thickness (mm)	Dimension (mm)
48.612	Adhesive	1 pc	3	750 x 1.200



Varenr.	Thickness (mm)	Dimension (mm)
48.618	10	1.250 x 1.500

## Tilbehør / Accessory

68.4250



Alutape til samling af motorisolerings. 50 mm x 10 m.  
Alu tape for the assembly of motor insulation. 50 mm x 10 m.

63.55030



Plastskive Ø50 mm til montering af motorisolerings.  
Plastic disc with 50 mm diameter for mounting of motor insulation.



### KINA GUMMIPLADER - COMMERCIAL QUALITY

Varene er prisgunstige alternativer til Europa plader. Ikke en erstatning for europæiske kvaliteter.

Hele ruller leveres i plastfolie. Pladerne er et godt alternativ til hovedparten af de gængse opgaver. Anbefales ikke til højkvalitetspakninger med store krav til tolerancer og mekanisk styrke. Sammenlign evt. de tekniske beskrivelser. Pladerne har større tykkelsestolerancer end de europæiske. Mange andre kvaliteter kan skaffes i større mængder.

### CHINA RUBBER SHEETS - COMMERCIAL QUALITY

Excellent alternatives to European sheets at very favourable prices. SHOULD NOT be understood as a substitute for European qualities. The rubber sheets are delivered on rolls wrapped in plastic. The sheets are good alternatives for most common tasks. Cannot be recommended for high-quality seals with high demands on tolerances and mechanical strength. In case of doubt please compare the technical descriptions. The sheets have higher tolerances on thickness than the European ones. Many other qualities are available if large quantities are required.

### Gummimåtter / Rubber sheets

Sort prisgunstig gummiplade til almen brug, hvor der ikke stilles større krav til trækstyrke. Bruges til pakninger, mellemlæg m.m.

Black commercial rubber mat for normal use, where there are no specific demands on tensile strength. Useful for seals.

Art.	Thickness (mm)	Width (mm)	Length (mm)	Insertion
38.400-1.5	1,5	1.400	20.000	0
38.400-2	2	1.400	20.000	1
38.400-3	3	1.400	20.000	1
38.400-4	4	1.400	20.000	1
38.400-5	5	1.400	10.000	1
38.400-6/650	6	650	10.000	2
38.400-6	6	1.400	10.000	2
38.400-8	8	1.400	10.000	2
38.400-10	10	1.400	10.000	2
38.400-12	12	1.400	10.000	2
38.400-15	15	1.400	5.000	0
38.400-20	20	1.400	5.000	0
38.400-25	25	1.400	5.000	0

### Gummimåtter / Rubber sheets

Bus- og tog-gangmåtte, marble-mønster/farve. 2 meter bredde, fås i 25 meters ruller.

Bus and train walk-away mat, marble pattern/color. 2 metres wide, length 25 metres.

Art.	Thickness (mm)	Width (mm)	Length (mm)	Insertion
38.428	3	2.000	25.000	0

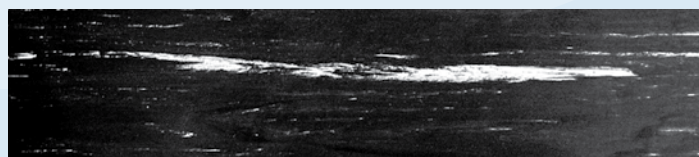

Data	
Gummi / Rubber	NR / SBR
Farve / Color	Black
Kvalitet / Quality	Commercial
Hårdhed / Hardness - Shore A	70
Densitet / Gravity - g/cm <sup>3</sup>	1,55
Forlængelse / Elongation - %	200
Arbejdstemperatur / Working temperature - °C	-20 +70
Trækstyrke / Tensile strength - N/mm <sup>2</sup>	4

Data	
Mønster / Design	Marmor / Marble
Farve / Color	Black
Kvalitet / Quality	Commercial
Hårdhed / Hardness - Shore A	70
Densitet / Gravity - g/cm <sup>3</sup>	1,5
Forlængelse / Elongation - %	250
Arbejdstemperatur / Working temperature - °C	-40 +80
Trækstyrke / Tensile strength - N/mm <sup>2</sup>	3,5

## Blød paragummi/naturgummi / Soft para rubber

Rød naturgummiplade. Meget blød, meget elastisk, stor friktion.

Red natural rubber sheet, very soft. Highly elastic, good friction.

Art.	Thickness (mm)	Width (mm)	Length (mm)	Insertion
38.401-2	2	1.400	10.000	0
38.401-3	3	1.400	10.000	0
38.401-4	4	1.400	10.000	0
38.401-5	5	1.400	10.000	0
38.401-6	6	1.400	10.000	0
38.401-10	10	1.400	10.000	0
38.401-15	15	14.000	5.000	0
38.401-20	20	14.000	5.000	0

Data	
Gummi / Rubber	Natur
Farve / Color	Rød / Red
Kvalitet / Quality	Commercial
Hårdhed / Hardness - Shore A	40
Densitet / Gravity - g/cm <sup>3</sup>	1,25
Forlængelse / Elongation - %	550
Arbejdstemperatur / Working temperature - °C	-20 +90
Trækstyrke / Tensile strength - N/mm <sup>2</sup>	18

## EPDM Gummi Sort / Black

Sort EPDM gummi, meget god ozon- og vejrbestandighed.

God temperaturbestandighed.

Black EPDM rubber with high resistance to ozon and climate. Very resistant to cold and hot applications.

Art.	Thickness (mm)	Width (mm)	Length (mm)	Insertion
38.402-0,5	0,5	1.200	10.000	0
38.402-1X	1	1.400	20.000	0
38.402-2X	2	1.400	10.000	0
38.402-3X	3	1.400	10.000	0
38.402-4X	4	1.400	10.000	0
38.402-5X	5	1.400	10.000	0

Data	
Gummi / Rubber	EPDM
Farve / Color	Sort / Black
Kvalitet / Quality	Commercial
Hårdhed / Hardness - Shore A	70
Densitet / Gravity - g/cm <sup>3</sup>	1,30
Forlængelse / Elongation - %	300
Arbejdstemperatur / Working temperature - °C	-40 +100
Trækstyrke / Tensile strength - N/mm <sup>2</sup>	6 - 7

## CR / Chloroprene Sort / Black

Sort CR gummiplade god vejr/vind- og ozonbestandighed, egnet hvor der ikke stilles krav til træk/rivstyrke. Betinget oliebestandig.

Black CR rubber plate, good climate resistance, used where there are no specific demands to tensile strength. Conditional oil resistance.

Art.	Thickness (mm)	Width (mm)	Length (mm)	Insertion
38.403-2	2	1.400	20.000	0
38.403-3	3	1.400	20.000	0
38.403-4	4	1.400	20.000	0
38.403-5	5	1.400	10.000	0
38.403-6	6	1.400	10.000	0
38.403-8	8	1.400	10.000	0

Data	
Gummi / Rubber	CR
Farve / Color	Sort / Black
Kvalitet / Quality	Commercial
Hårdhed / Hardness - Shore A	65
Densitet / Gravity - g/cm <sup>3</sup>	1,55
Forlængelse / Elongation - %	280
Arbejdstemperatur / Working temperature - °C	-40 +90
Trækstyrke / Tensile strength - N/mm <sup>2</sup>	3,5

## Kinagummiplader / Rubber sheets from China

### NBR / NITRIL - Sort / Black

Sort prisgunstig nitril med gode mekaniske egenskaber. Egnede til alle alifatisk og aromatiske olier, benzin.

Black commercial nitrile with good mechanical properties. Recommended for aliphatic and aromatic oils, petrol.

Art.	Thickness (mm)	Width (mm)	Length (mm)	Insertion
<del>38.304-1.5 **</del>	<del>1,5</del>	<del>1.400</del>	<del>20.000</del>	<del>0</del>
38.404-2	2	1.400	20.000	0
38.404-3	3	1.400	20.000	0
38.404-4	4	1.400	20.000	0
38.404-5	5	1.400	10.000	0
38.404-6	6	1.400	10.000	0
38.404-8	8	1.400	10.000	0
38.404-10	10	1.400	10.000	0
38.404-12	12	1.400	5.000	0
38.404-15	15	1.400	5.000	0
38.404-20 *	20	1.400	5.000	0

Data	
Hårdhed / Hardness - Shore A	70
Densitet / Density - g/cm <sup>3</sup>	1,49
Kvalitet / Quality	Commercial
Forlængelse / Elongation - %	330
Arbejdstemperatur / Working temperature - °C	-30 +70
Trækstyrke / Tensile strength - N/mm <sup>2</sup>	10

### Slid-gummi / Wearing rubber - Sort / Black

Slidgummi med høj træk/rivstyrke.

Egnede til alle stærkt slidende applikationer, grusgrave, sandblæsekabiner

Wearing/abrasion rubber with high tensile strength.

Recommended for wearing application, gravel pits, sandblasting.

Art.	Thickness (mm)	Width (mm)	Length (mm)	Insertion
38.405-6	6	1.400	10.000	0
38.405-8 *	8	1.400	10.000	0
38.405-10	10	1.400	10.000	0
38.405-10X *	10	2.000	10.000	0
38.405-15	15	1.400	10.000	0
38.405-20 *	20	1.400	5.000	0
38.405-40 *	40	1.200	7.000	0

Data	
Hårdhed / Hardness - Shore A	60
Densitet / Density - g/cm <sup>3</sup>	1,30
Forlængelse / Elongation - %	400
Arbejdstemperatur / Working temperature - °C	-30 +70
Trækstyrke / Tensile strength - N/mm <sup>2</sup>	15

NR/SBR - Sort / Black - Grå / Grey

\*\* = sort / black - 100% virgin quality SBR

Lugtfri / non-smelling

Finnriflet gummiplade, skridsikker plade til kabiner, arbejdsborde, hylder, gangarealer, køretøjer, sportsaktiviteter, udstillinger.

Fine-ribbed rubber mat, non-slip coverings for cabins, working benches, shelves, corridors, vehicles, sporting facilities, exhibition floors.

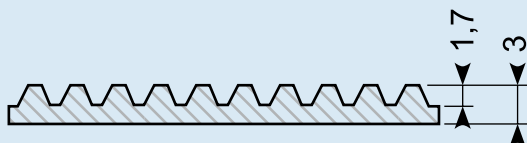

Art.	Thickness (mm)	Width (mm)	Length (mm)	Insertion	Color
38.407-3X **	3	1200	20000	0	Black
38.407-3 **	3	1400	20000	0	Black
38.407-3C	3	1400	20000	0	Black
38.407-3G	3	1400	20000	0	Grey
38.407-3XL	3,5	1.800	10.000	0	Black

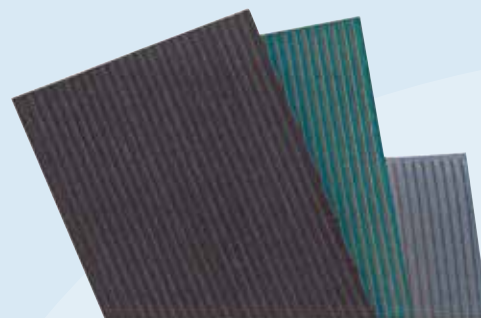

Data	38.407-3C	**
Hårdhed / Hardness - Shore A	70	70
Densitet / Density - g/cm <sup>3</sup>	1,6	1,6
Forlængelse / Elongation - %	280	280
Arbejdstemperatur / Working temperature - °C	-10 +70	-20 +70
Trækstyrke / Tensile strength - N/mm <sup>2</sup>	3,5	5

Busmåtte / Bus mats

NR / SBR = Natur / SBR

Mellemriflet plade, egnet til gulv og vægbeklædning til busser, både, dyretransport, værksteder mm.

Medium-ribbed mat, recommended for floors and walls for buses, boats, animal transport, work shops.

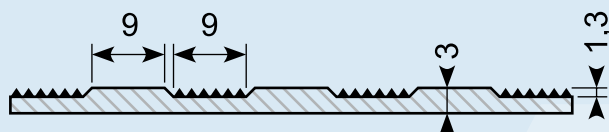

Art.	Thickness (mm)	Width (mm)	Length (mm)	Insertion
38.418	3	1.500	15.000	0
38.418N *	3	1.500	15.000	0



Data	38.418 NR / SBR	38.418N NBR
Hårdhed / Hardness - Shore A	70	70
Densitet / Density - g/cm <sup>3</sup>	1,6	1,45
Kvalitet / Quality	Commercial	Commercial
Forlængelse / Elongation - %	280	250
Arbejdstemperatur / Working temperature - °C	-10 +70	-10 +70
Trækstyrke / Tensile strength - N/mm <sup>2</sup>	3,5	6

Busmåtte / Bus mats - Commercial Quality

NR / SBR = Natur / SBR

\*\* = Sort / Black - 100% virgin quality SBR

Lugtfri / Non smelling

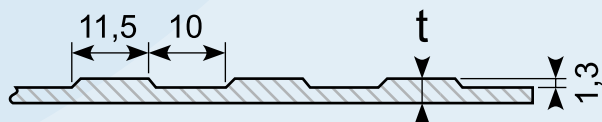

Art.	Thickness (t) (mm)	Width (mm)	Length (mm)	Insertion
38.421C	5	1.400	10.000	0
38.420C	5	2.000	10.000	0
38.419 **	3,5	2.000	10.000	0
38.419X **	3,5	1.400	20.000	0
38.420 **	5	2.000	10.000	0
38.420 BOX ** (Wooden box)	5	2.000	50.000	0



Bredriflet plade, egnet til gulv og vægbeklædning til busser, både, dyretransport, værksteder mm.

Wide-ribbed mat, recommended for floors and walls for buses, boats, animal transport, work shops.

Data	NR / SBR	SBR **
Hårdhed / Hardness - Shore A	70	70
Densitet / Density - g/cm <sup>3</sup>	1,6	1,6
Forlængelse / Elongation - %	280	280
Arbejdstemperatur / Working temperature - °C	-10 +70	-10 +70
Trækstyrke / Tensile strength - N/mm <sup>2</sup>	3,5	5

## Kinagummiplader / Rubber sheets from China

Diamantmätte / Diamond mat

Skridsikker PVC-mätte

PVC mat non-skid

Art.	Thickness (mm)	Width (mm)	Length (mm)	Insertion
37.245P	3	1.200	10.000	0

Current stock available



Data	
Hårdhed / Hardness - Shore A	80
Densitet / Density - g/cm <sup>3</sup>	1,6
Forlængelse / Elongation - %	280
Arbejdstemperatur / Working temperature - °C	-10 +70
Trækstyrke / Tensile strength - N/mm <sup>2</sup>	3,5

Knopmätte / Studded Flooring

Knopmätte, anbefales til trafikerede arealer, metro, lufthavne, supermarkeder, elevatorer, busser, toge, lastbiler, både m.m.

Studded flooring, recommended for high traffic areas such as metro, airports, supermarkets, lifts, buses, trains, trucks, boats.

Art.	Thickness (mm)	Width (mm)	Length (mm)	Insertion	Color
38.427-3C	3,5	1.200	10.000	0	Black
38.427-3GC	3,5	1.200	10.000	0	Grey



Data	Black	Grey
Hårdhed / Hardness - Shore A	65 - 70	65 - 70
Densitet / Density - g/cm <sup>3</sup>	1,5	1,6
Kvalitet SBR / Quality SBR	Commercial	Commercial
Forlængelse / Elongation - %	150	150
Arbejdstemperatur / Working temperature - °C	-20 +70	-20 +70
Brudstyrke / Tear resistance - N/mm <sup>2</sup>	3	3

Dørkmätte / Checker mat

Dørkmätte til industrigulve og maskinområder, varehuse, trafikerede områder, skridsikker overflade.

Studded flooring, recommended for high traffic areas such as metro, airports, supermarkets, lifts, buses, trains, trucks, boats.

Art.	Thickness (mm)	Width (mm)	Length (mm)	Insertion	Color
38.425-3	3	1.400	10.000	0	**
38.425-3C	3	1.400	10.000	0	C
38.425-5	5	1.400	10.000	0	**
38.425-5C	5	1.400	10.000	0	C
38.425N-3	3	1.400	10.000	0	NBR
38.425N-5	5	1.400	10.000	0	NBR
38.426-3	3	2.000	10.000	0	**
38.426-3C	3	2.000	10.000	0	C
38.426-5	5	2.000	10.000	0	**
38.426-5C	5	2.000	10.000	0	C
38.426-8C	8	2.000	10.000	0	C



Data	NR / SBR	NR / NBR Virgin **	NBR
Hårdhed / Hardness - Shore A	70	70	70
Densitet / Density - g/cm <sup>3</sup>	1,6	1,6	1,45
Forlængelse / Elongation - %	350	350	250
Arbejdstemperatur / Working temperature - °C	-10 +70	-10 +70	-10 +70
Trækstyrke / Tensile strength - N/mm <sup>2</sup>	3,5	5	6

NR/SBR = Natur / SBR

NBR = Oliebestandig / oil resistant

\*\* = 100% Virgin quality lugtfri / non smelling / geruchsfrei

C = commercial quality

Viton-gummi

Art.	Thickness (mm)	Width (mm)	Length (mm)	Insertion
38.429-2 *	2	1.200	10.000	0

Min. order: 12 m<sup>2</sup>

Data	
Hårdhed / Hardness - Shore A	70
Densitet / Density - g/cm <sup>3</sup>	-
Forlængelse / Elongation - %	250
Arbejdstemperatur / Working temperature - °C	-
Trækstyrke / Tensile strength - N/mm <sup>2</sup>	7

\* Skaffevare / Special order item



## Rampemåtte / Rear Board Matting

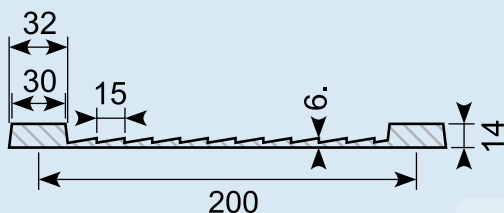

SBR - Sort / Black - Commercial

Art.	Thickness (mm)	Width (mm)	Length (mm)
37.250X	6/14	1.750	1.550

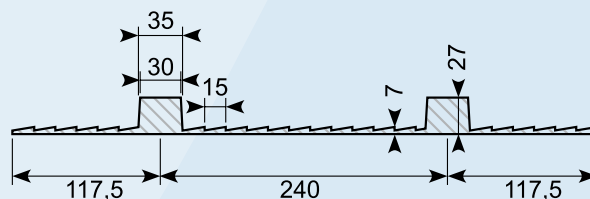

SBR - Sort / Black - Commercial

Art.	Thickness (mm)	Width (mm)	Length (mm)
37.251X		2.400	1.200

Data	37.250X	37.251
Hårdhed / Hardness - Shore A	SBR 70	SBR 65
Densitet / Gravity - g/cm <sup>3</sup>	1,5	1,55
Forlængelse / Elongation - %	250	200
Arbejdstemperatur / Working temperature - °C	-40 +80	-20 +75
Trækstyrke / Tensile strength - N/mm <sup>2</sup>	4	4,5

## Gummimåtter / Rubber mats

### Ergo Solid

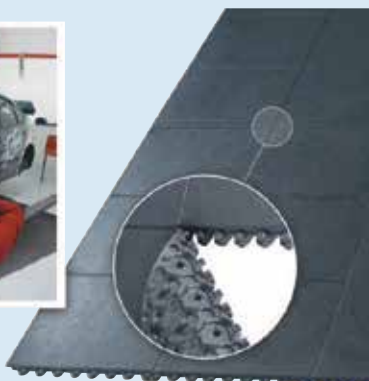

#### Ergo Solid - tegn på ergonomisk indsigt

Ergo Solid er en nitrilgummimåtte med fantastiske gode aflastnings-egenskaber og slidstyrke. Pladerne kan sammensættes fleksibelt uden anvendelse af samlingsstykker. Velegnet til arbejdspladser i industrien med enten tørt eller fedtet miljø.

- Tåler kontakt med varmt værktøj
- oliebestandig
- Ryg og ben aflastes effektivt, hvilket resulterer i høj produktivitet og lavere sygefravær
- Affasede kanter minimerer risikoen for at snuble - findes ligeledes i gul for markering af arbejdsområde m.v.

#### Ergo Solid - shows ergonomical knowledge

Ergo Solid is a wear-resistant nitril rubber mat with excellent strain relief. The sheets may be joined together without the use of fittings. Suitable for workplaces in the industrial field - for dry or greasy environments.

- Tolerates contact with hot tools
- Oil resistant
- Bag and legs are effectively relieved resulting in a high productivity and less absence due to sickness.
- Chamfered edges keep the risk of stumbling to a minimum
- Available in yellow to mark the work area etc.

Art.	Name	Color	Size (m)	Height (mm)	Weight (kg)
38.9726230	Ergo Solid	Sort	0,91 x 0,91	19	8,2
38.9730030*	Skrå kant - male	Sort	0,08 x 0,91		1
38.9750030	Koppling	Sort	0,03 x 0,23		0,1
38.9730030S*	Skrå kant - female				

\* Ved kant rundt om hele måtten. Bruges 2 han + 2 hun skråkanter. Grundmåtten har udvendige tappe på 2 sider.

\* At the edge around the entire mat. Use 2 male + 2 female edges. The basic mat has exterior pins on 2 sides.

### Ergo Bubble



#### Boblemåtte

Ergo Bubble er en traditionel boblemåtte fremstillet af skum-polyuretan. Materialet har unikke elastiske egenskaber som sammen med buerne i overfladen får benmusklerne til at arbejde og giver en god aflastning - samtidig med at den har meget høj slidstyrke. Måtten findes i flere standardstørrelser men kan derudover fremstilles efter dine specialmål. Samtlige Ergo Bubble har affasede kanter for at minimere snublerisikoen.

Er velegnet i alle tørre miljøer.

Art.	Name	Color	Size (m)	Weight (kg)
38.8100110	Ergo Bubble	Grafit	0,65 x 0,95	3,2
38.8100310	Ergo Bubble *	Grafit	0,65 x 1,8	4
38.8103110	Ergo Bubble *	Grafit	0,95 x 1,2	4



**Kan skaffes i oliebestandig NBR /**  
**Obtained in oil resistant NBR**  
 0,65 x 1,4 m  
 0,95 x 1,5 m  
 0,95 x 1,8 m

#### Bubble mat

Ergo Bubble is a traditional bubble mat made from foam-polyurethane. The material has unique elastic properties which, together with the bubbles in the surface, make the leg muscles work and provide excellent strain relief - at the same time the mat is extremely hard-wearing.

Available in several standard sizes - or custom-designed according to your special dimensions. All Ergo Bubble have chamfered edges to reduce the risk of stumbling to a minimum.

Suitable for use in all dry environments.

## Ergo Durk



En klassiker til mange arbejdspladser

Ergo Durk er en klassisk arbejdspladsmåtte med dørkmønstreret overside i nitrilgummi. Bagsiden er af EPDM-cellegummi med lukkede celler.

Kombinationen af disse miljøvenlige materialer giver en både slidstærk og behagelig måtte at stå på. Desuden yders der 5 års komplet slitagaranti.

Fås i standardmåtte fra rulle eller i specialmål efter tegning, alt med af-fasede kanter.

**Ergo Durk ESD** beskytter også følsomt elektronik imod statisk elektricitet. Måtten er godkendt i henhold til SP 2472.

Art.	Name	Color	Size (m)	Weight (kg)
38.5017530 **	Ergo Durk	Sort	1,4 x 1	6,6
38.5017530 **	Ergo Durk	Sort	1,4 x 10	66



\* Måtten har en gummioverside og en underside af EPDM.

\* The mat has a rubber top side and a bottom side of EPDM.

A Classic for Many Workplaces

Ergo Durk is a classic workplace mat with a surface patterned like the deck of a ship and the upper side made of nitrile rubber. The back side is made of EPDM cellular rubber with closed cells.

The combination of these environmentally compatible materials provides a both hard-wearing and pleasant mat. Furthermore, there is a five-year guarantee against wear.

Available as a standard mat in a roll or in sheets specially made according to drawing - all with chamfered edges.

**Ergo Durk ESD** also protects sensitive electronics against static electricity. The mat has been approved acc. to SP 2472.

## Ergo Dome



**Ergo Dome, god måtte til gunstig pris**

Ergo Dome er en slidstærk måtte i naturgummi (SBR).

Den buleformede overflade stimulerer blodcirkulationen hvilket mindsker belastningsskader i ben og ryg.

**Ergo dome, good mat at low prices.**

Ergo dome is a durable mat of natural rubber (SBR).

The bulge-shaped surface stimulates blood circulation, which reduces stress injuries in the legs and back.

Art.	Name	Color	Size (m)	Weight (kg)
38.410200	Ergo Dome	Sort	0,6 x 0,9	3,2
38.410201	Ergo Dome	Sort	0,9 x 1,2	4
38.410203	Ergo Dome Puzzle midterstykke	Sort	0,9 x 1,2	4
38.410202	Ergo Dome Puzzle, endestykke	Sort	0,9 x 1,2	4

Puzzle er med sorte kanter, og det er muligt at samle 2 endestykker til f.eks. 2,4 m

Puzzle is with black borders, and it is possible to assemble two end pieces, for example 2.4 m.

**Kan skaffes i oliebestandig NBR /**  
Obtained in oil resistant NBR  
0,6 x 0,9 m  
0,9 x 1,2 m

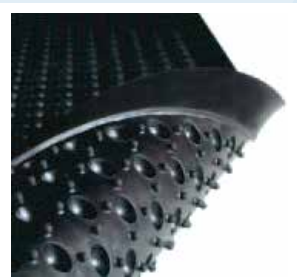
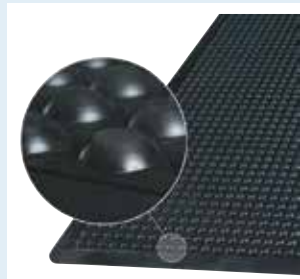

## Gummimåtter / Rubber mats

### Ergo Ring



**Kan skaffes i / Obtained in**  
0,4 x 0,6 og 0,6 x 0,8



Skridsikker i vådt og tørt

Ergo Ring bortdræner effektivt væde og spildmateriale, hvilket sikrer en skridsikker overflade at stå på. Den åbne ringkonstruktion giver desuden en god aflastning.

- Kan samles, hvilket giver mulighed for store sammenhængende, skridsikre overflader
- Dræner effektivt, ideel ved bearbejdningsmaskiner eller i våde lokaler
- God som grov dørmåtte i entreer
- Naturgummi med den rette hårdhed giver skridsikkerhed både i tørt og vådt miljø

Non-skid in wet and dry environment

Ergo Ring effectively drains off wet and waste material, which ensures a non-skid surface. The open annular construction provides an excellent strain relief.

- May be joined together to large coherent non-skid surfaces
- Drains effectively, ideal for machine tools or in wet premises
- Applicable as a coarse entrance door mat
- Natural rubber with the correct hardness provides skid resistance in both wet and dry environments.

Art.	Name	Color	Size (m)	Height (mm)	Weight (kg)
38.9117630	Ergo Ring	Sort	0,8 x 1,2	23	11
38.9117631	Ergo Ring	Sort	1 x 1,5	23	21
38.9110030	Samlestykke	Sort			

### Ergo Ease



Art.	Name	Color	Size (m)	Height (mm)	Weight (kg)
38.9716230	Ergo Ease	Sort	0,91 x 0,91	14	8,2 kg

**Kan skaffes i terracottarød / Obtained in terracotta red**

Ergo Ease - kongen af aflastning

Ergo Ease er en nitrilgummimåtte med ekstremt gode aflastningsegenskaber og slidstyrke. Pladerne kan sammensættes fleksibelt uden anvendelse af samlingsstykker.

Velegnede til arbejdspladser i industrien med enten tørt eller fedtet miljø.

- Tåler kontakt med varmt værktøj
- Oliebestandig
- Ryg og ben aflastes effektivt, hvilket resulterer i høj produktivitet og lavere sygefravær
- Affasede kanter minimerer risikoen for at snuble - findes ligeledes i gul for markering af arbejdsområde m.v.

Ergo Ease - first-quality strain relief

Ergo Ease is a wear-resistant nitril rubber mat with excellent strain relief. The sheets may be joined together without the use of fittings. Suitable for workplaces in the industrial field in a dry or greasy environment.

Tolerates contact with hot tools

Oil resistant

Back and legs are effectively relieved resulting in a high productivity and less absence due to sickness.

Chamfered edges keep the risk of stumbling to a minimum. Available in yellow to mark the work area etc.

## Ergo Classic



Komfort og økonomi i samme måtte

Ergo Classic er den ideelle måtte til den stående arbejdsplads, hvor man også bevæger sig inden for arbejdsfeltet. God skridsikkerhed på den ribbede overflade. Ergo Classic har 3 års fuld slitagegaranti. Nem at tilpasse selv med en almindelig tæppekniv.

Ideal til monteringslinjer m.v.  
 God skridsikkerhed  
 Isolerer effektivt imod kulde og vibrationer  
 God økonomi  
 Fås ligeledes med farvede kanter for markering af arbejdsområde m.v.

Tykkelse: 10 mm

Art.	Name	Color	Size (m)	Weight (kg)
38.5501110	Ergo Classic	Grå	0,61 x 18,3	36 kg
38.5501210	Ergo Classic	Grå	0,91 x 18,3	50 kg
38.5501310 **	Ergo Classic	Grå	1,22 x 18,3	65 kg



Comfort and economy in the same mat

Ergo Classic is the ideal mat for standing work where you move within the working area. The ribbed surface provides skid resistance. There is a full three-year guarantee against wear. Easy to adapt with an ordinary carpet knife.

Ideal for  
 Non-skid quality  
 Effective insulation against cold and vibrations  
 Economical  
 Is also available with coloured borders for marking the working area etc.

10 mm thick.

## Fingertip



Art.	Name	Color	Size (m)
38.345522	Fingertip	Sort	0,8 x 1

Fingertip gummimåtte med skrå kant.  
 Fingertip rubber mat with beveled edge.

## Smudsmåtter diamond blue / mat diamond blue

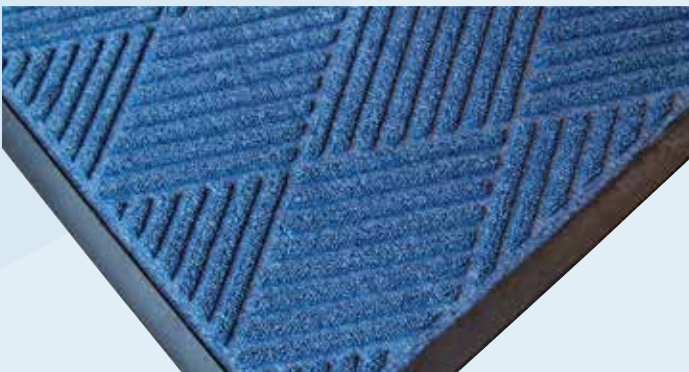

Art.	Color	Size (m)
38.623750	Blue	0,9 x 1,5
38.623752	Blue	0,6 x 0,9
38.623764	Blue	1,2 x 1,8

Dørmåtte blå, polypropylen med gummiskråkant.  
 Kan spules med højtryksrensere.

Blue mat, polypropylene with rubber beveled edge.  
 Can be flushed with high-pressure cleaner.

**Kan skaffes i grå / Obtained in grey**

## Gummimåtter / Rubber mats

### Vibrationsmatte / Vibration mat

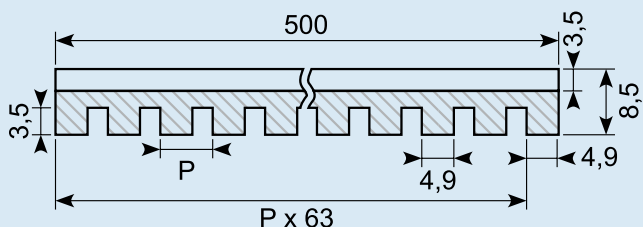
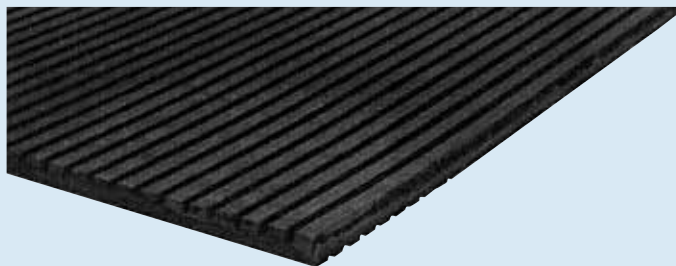

### NR/SB

Art.	Thickness (mm)	Width (mm)	Length (mm)	Insertion
37.400	8,5	500	500	0

Sort, kommerciel gummiplade.  
Anvendes mellem maskiner og gulv for at minimere og optage vibrationer.  
Riller på begge sider.  
Bæreevne 5 kg/cm<sup>2</sup>

Black commercial rubber plate.  
To be used between machines and floor in order to minimize and absorb vibrations. Grooves on both sides.  
Carrying capacity of 5 kg/cm<sup>2</sup>.

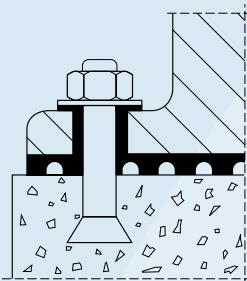

### Komåtte / Cow mat (NR / SBR)

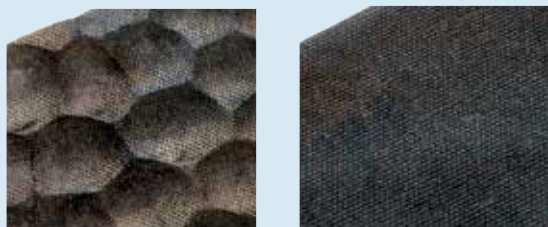

Art.	Width (mm)	Length (mm)	Thickness (mm)	Shore	Density
38.440-6	2.000	30.000	6	65	1,45
38.440-8	2.000	30.000	8	65	1,45
38.440-8X	1.250	10.000	8	65	1,45
38.440-6A	1.750	21.000	6	65	1,45
38.440-8A	1.750	21.000	8	65	1,45

### Komåtte / Cow mat (NR / SBR)

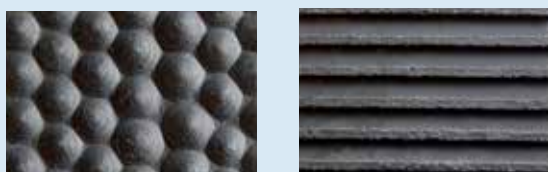

Art.	Thickness (mm)	Width (mm)	Length (mm)
37.260	10	2.000	20.000
37.261 *	10	2.000	4.870
37.262 *	10	2.000	6.522

#### 37.280



Grisemåtte 1.810 x 1.210 x 30 mm.  
Cirkler / hul bund uden indlæg.  
Pigs mat 1.810 x 1.210 x 30 mm.  
Circles / hollow bottom without insert.

#### 37.263



Komåtte 2.200 x 10.000 x 16 mm. Overflade cirkler u/indlæg. Bund ribbet i længderetning.  
Cow mat 2.200 x 10.000 x 16 mm. Surface circles without insert. The bottom ribbed in longitudinal direction.

#### 37.270



Komåtte 1.830 x 1.220 x 17 mm.  
Knopper / ribbet bund uden indlæg.  
Cow mat 1.830 x 1.220 x 17 mm. Studs / ribbed bottom without insert.

### Traileråtte / Trailer mat



Data	
Gummi / Rubber	NR / SBR
Hårdhed / Hardness - Shore A	65
Densitet / Density - g/cm <sup>3</sup>	1,4
Arbejdstemperatur / Working temperature - °C	-25 +70
Trækstyrke / Tensile strength - N/mm <sup>2</sup>	12

Art.	Thickness (mm)	Width (mm)	Length (mm)
38.422-1350	6	1.350	21.000
38.422-1650	6	1.650	21.000
38.422-1750 *	6	1.750	21.000
38.423-1650	8	1.650	21.000
38.423-1750 *	8	1.750	21.000
38.424-1800 *	8	1.800	21.000

\* Skaffevare / Special order item

## Klar PVC / Transparent PVC

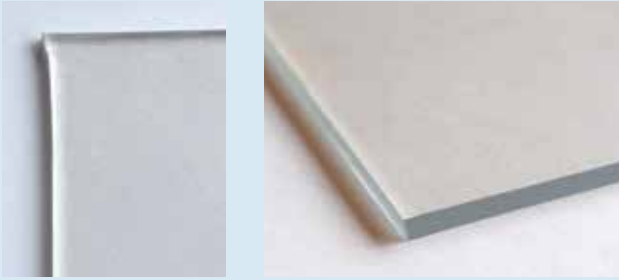

Art.	Thickness (mm)	Width (mm)	Length (mm)
38.449-750 *	3	750	20.000
38.449-1200	3	1.200	20.000
38.450-760 *	4	760	13.000
38.451-1600	5	1.600	20.000
38.452-1200 *	7	1.200	10.000

## Polyurethanplader / Polyurethane plates



Art.	Thickness (mm)	Width (mm)	Length (mm)	Stock
38.430-5/70	5	2.000	1.000	X
38.430-5/80	5	2.000	1.000	X
38.430-8/70	8	2.000	1.000	X
38.430-8/90	8	2.000	1.000	X
38.430-10/70	10	2.000	1.000	X
38.430-10/90	10	2.000	1.000	X

\*\*

Data				
Hårdhed / Hardness - Shore A	70	80	90	
Forlængelse / Elongation	500-600	450-500	400-450	
Arbejdstemperatur / Working temperature - °C	-35 +100	-35 +100	-35 +100	
Rivstyrke / Tear strength - KN/m	50	50	50	
Trækstyrke / Tensile strength - N/mm <sup>2</sup>	25	30	35	

### 37.221/1G

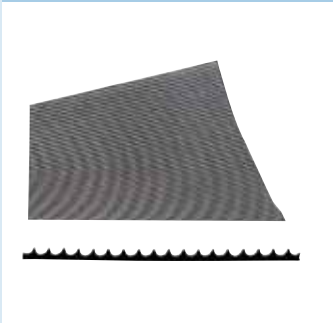

Material: Grey  
Size: 1.000 x 10.000 x 3 mm

### 38.14124 \*

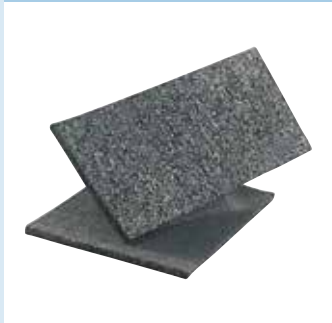

Anti slip plade. Gummigranulat.  
Anti slip plate. Rubber granules.  
8 x 100 x 200 mm  
Min. order: 300

### 38.14572 \*

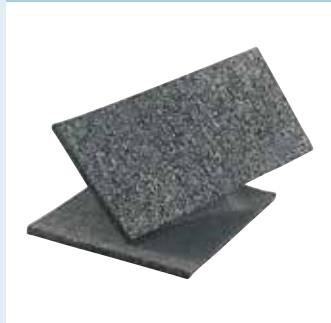

Anti slip plade. Gummigranulat.  
Anti slip plate. Rubber granules.  
8 x 500 x 5000 mm  
Min. order: 5 m

### 38.9971010 \*

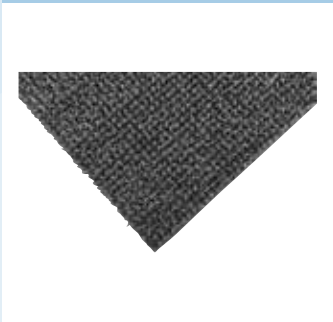

Græsmåtte. Grå  
Grass mat. Grey  
900 mm x 16 m

### 38.9971020 \*



Græsmåtte. Grøn  
Grass mat. Green  
900 mm x 16 m

## Gummimåtter / Rubber mats

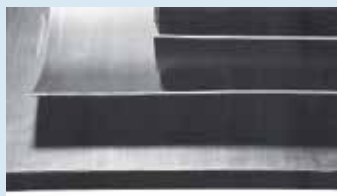

Bus mats EU Semperit  
Material: NR / NBR / NR-SBR

Art.	Width (mm)	Thickness (mm)	Quality	Color	Insert
38.121N *	1.400	1	NBR	Black	0
38.121NX *	1.400	1	NBR	Black	0
38.1215N	1.400	1,5	NBR	Black	0
38.122N *	1.400	2	NBR	Black	0
38.123N *	1.400	3	NBR	Black	0
38.124N *	1.400	4	NBR	Black	0
38.125N *	1.400	5	NBR	Black	0
38.125S *	1.400	5	NBR	Black	0
38.126N *	1.400	6	NBR	Black	0
38.128N	1.400	8	NBR	Black	0
38.128NH	1.400	8	NBR	White	0
38.128S *	1.400	8	NBR	Black	0
38.130N *	1.400	10	NBR	Black	0
38.132N *	1.400	12	NBR	Black	0
38.135N *	1.400	15	NBR	Black	0
38.139N *	1.400	20	NBR	Black	0
38.1215	1.400	1,5	NR / SBR	Black	1
38.1215NH *	1.400	1,5	NR / SBR	White	1
38.122	1.400	2	NR / SBR	Black	1
38.122A *	1.400	2	NR / SBR	Black	2
38.123 *	1.400	3	NR / SBR	Black	1
38.123X *	1.400	3	NR / SBR	Black	Smooth
38.124	1.400	4	NR / SBR	Black	1
38.125 *	1.400	5	NR / SBR	Black	1
38.126 *	1.400	6	NR / SBR	Black	2
38.128 *	1.400	8	NR / SBR	Black	2
38.128SX *	1.400	8	NBR / SBR	Black	Smooth
38.130	1.400	10	NR / SBR	Black	2
38.132 *	1.400	12	NR / SBR	Black	2
38.135 *	1.400	15	NR / SBR	Black	0
38.136 *	1.400	20	NR / SBR	Black	0
38.137 *	1.400	25	NR / SBR	Black	0
38.138 *	1.400	30	NR / SBR	Black	0
38.139 *	1.400	30	NR / SBR	Black	0
38.140 *	1.400	50	NR / SNR	Black	0
38.122EPDM	1.400	2	EPDM	Black	0
38.123EPDM	1.400	3	EPDM	Black	0



Rubber cork  
Material: NR / NBR / NR-SBR

Art.	Size (mm)	Thickness (mm)	Quality
38.201.5	1.000 x 1.000	1,5	1.235
38.202	1.000 x 1.000	2	1.235
38.203	1.000 x 1.000	3	1.235
<del>38.204</del>	<del>1.000 x 1.000</del>	<del>4</del>	<del>1.235</del>
38.205	1.000 x 1.000	5	1.235
38.205R *	1.060 x 13.000	5	1.235

\*\*

Udgået

Min. order: 4 rl.

\* Skaffevarer / Special order item \*\* Opdateret siden tryk / Updated since print

SINDBY PROFILES 4 - 00129-4-k201703



50.241NR



T-strap  
Material: NR  
Length: 150 mm

50.245NR



T-ladder  
Material: NR  
Length: 160 mm

50.245H



T-ladder  
Material: White EPDM  
Length: 160 mm

50.242NR



T-strap  
Material: NR  
Length: 250 mm

50.246NR \*\*

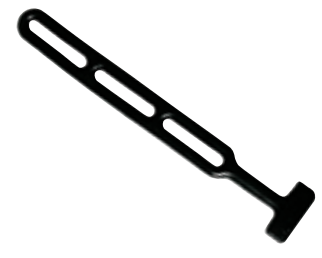

T-ladder  
Material: NR  
Length: 285 mm

50.265-10



Combi strap  
Material: NR  
Length: 275 x 25 mm  
(10 pcs. package)

50.246-10

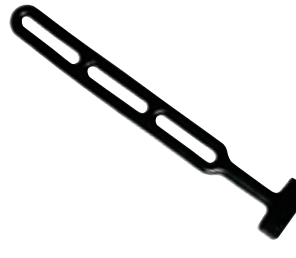

T-ladder  
Material: NR  
Length: 280 x 30 mm  
(10 pcs. package)

50.265



Combi strap  
Material: EPDM  
Length: 280 mm

50.266



Combi strap  
Material: EPDM  
Length: 360 mm

50.247-10



Combi strap  
Material: NR  
Length: 365 x 25 mm  
(10 pcs. package)

50.247NR \*\*

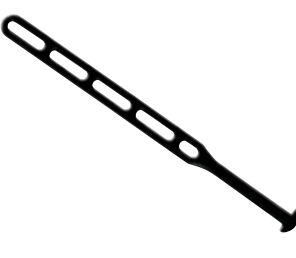

Combi strap  
Material: NR  
Length: 370 mm

50.275



POP ladder  
Material: EPDM  
Length: 200 mm

50.244NR

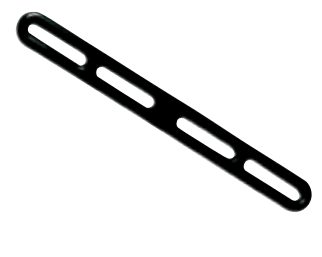

Strap  
Material: NR  
Length: 260 mm

50.271



Strap  
Material: EPDM  
Length: 270 mm

50.276

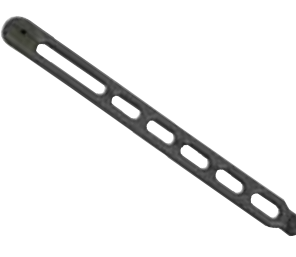

POP ladder  
Material: EPDM  
Length: 275 mm

50.264-10

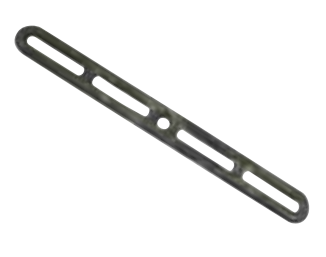

Strap  
Material: NR  
Length: 285 x 30 mm  
(10 pcs. package)

\*\* Opdateret siden tryk / Updated since print

## Gummistropfer / Rubber straps

50.264



Strap  
Material: NR  
Length: 290 mm

50.261



Strap  
Material: EPDM  
Length: 200 mm, Ø 8 mm

50.263



Strap  
Material: EPDM  
Length: 200 mm, Ø 7 mm

50.263K



Strap with hook  
Material: NR  
Length: 200 mm

50.243NR

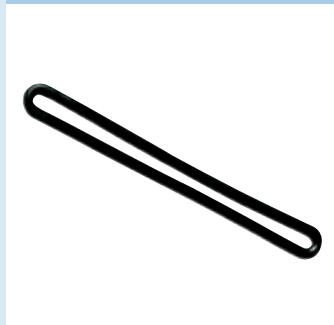

Strap  
Material: NR  
Length: 260 mm

50.267NR

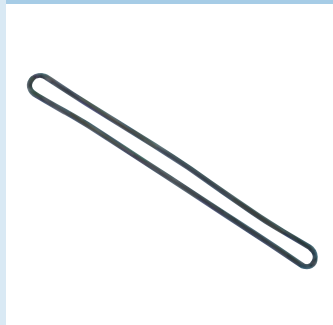

Strap  
Material: NR  
Length: 400 mm

50.267



Strap  
Material: EPDM  
Length: 400 mm

50.269



Ring  
Material: EPDM  
Length: Ø 106 mm / 86 mm

50.13621



Strap with hook and eye  
Length: 20 x 490 mm

50.280



Strap with hook and eye  
Length: Strop 480 mm  
Total 610 mm

50.250



Ladder strap  
Material: SBR  
Length: 10 m



Luggage strap

Art.	Measure (mm)
79.051	600
79.051A	700
79.052	900
79.053	1.250
79.054	1.750
79.055	3.000

**39.BUMPER**

Type A. Sort og gul.  
1.000 mm lang.  
Selvklæbende.

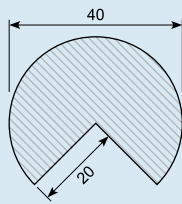

Type A. Black and yellow.  
1.000 mm long.  
Adhesive.

**39.BUMPERB**

Type B. Sort og gul.  
1.000 mm lang.  
Selvklæbende.

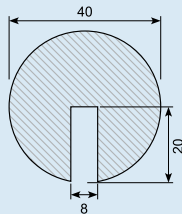

Type B. Black and yellow.  
1.000 mm long.  
Adhesive.

**39.BUMPERC**

Type C. Sort og gul.  
1.000 mm lang.  
Selvklæbende.

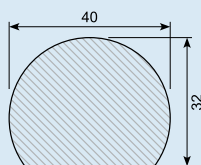

Type C. Black and yellow.  
1.000 mm long.  
Adhesive.

**39.BUMPERD \*\***

Type D. Sort og gul.  
1.000 mm lang.  
Selvklæbende.

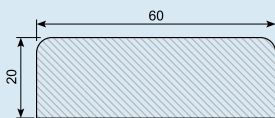

Type D. Black and yellow.  
1.000 mm long.  
Adhesive.

**39.BUMPERE**

Type E. Sort og gul.  
1.000 mm lang.  
Selvklæbende.

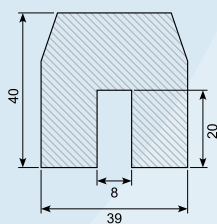

Type E. Black and yellow.  
1.000 mm long.  
Adhesive.

## Centraflex

**Centraflex. Vandtæt stanghængsel med polyester-kerne og PVC-flanger. Tillader 180 gr. åbning. Stor styrke og høj elasticitet. Sort finish. Længde: 2000 mm.**

Weather-proof continuous hinge with polyester-core and synthetic flanges. 165° opening, 28 mm face. High strength and excellent flexibility. Black finish. Length: 2000 mm.

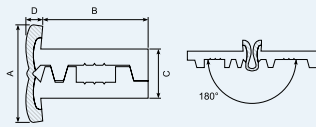
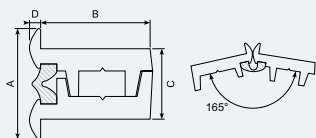

Art.	A mm	B mm	C mm	D mm	L mm
20.6020	28	23	16	4	2.000
20.6025	28	23	16	4	2.500
20.6030	28	23	16	4	3.000

Art.	A mm	B mm	C mm	D mm	L mm
20.6120	30	34	16	4,5	2.000
20.6125	30	34	16	4,5	2.500
20.6130	30	34	16	4,5	3.000

## Poliall \*\*

**Poliall stanghængsel, vandtæt. Med PU kerne og aluminiumsflanger. Tillader 180 gr. åbning. Forboret med 5 mm huller i flange.**

Poliall rod hinge, waterproof. With PU core and aluminum flanges. Allows 180 degree opening. Pre drilled with 5 mm holes in flange.

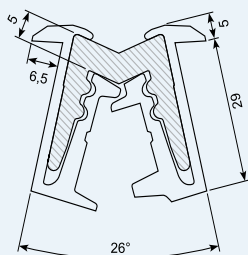
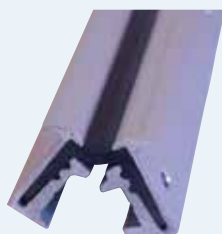

Art.	B mm	L mm
54.261700JX-5	29	2.200
54.261700J-5	29	2.400
54.261720J-5	29	2.700
54.261740J-5	29	3.000
54.261760J-5	29	3.200
54.261780J-5	29	4.000

## 20.13002

**Co-extruderet PVC-hængsel. 1.678 mm med Ø 5,3 mm forborede huller. Kun til lette opgaver.**

Co-extruded PVC hinge. 1678 mm, ø 5.3 mm holes pre-drilled holes. Only for light tasks.

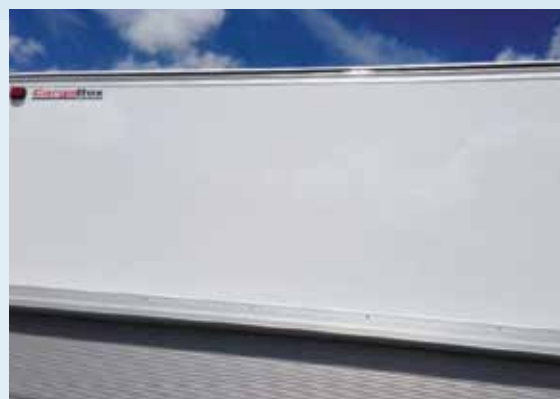
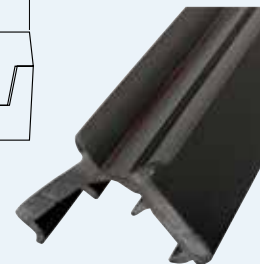
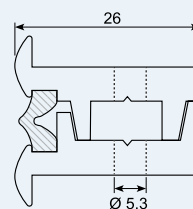

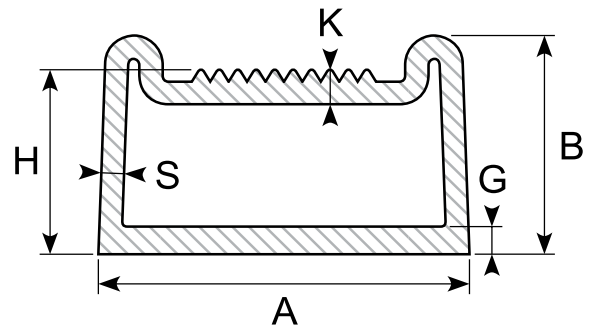
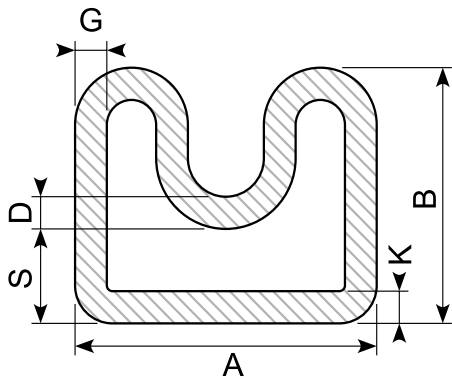
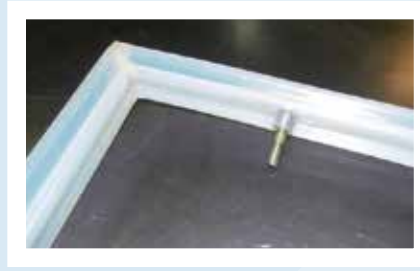
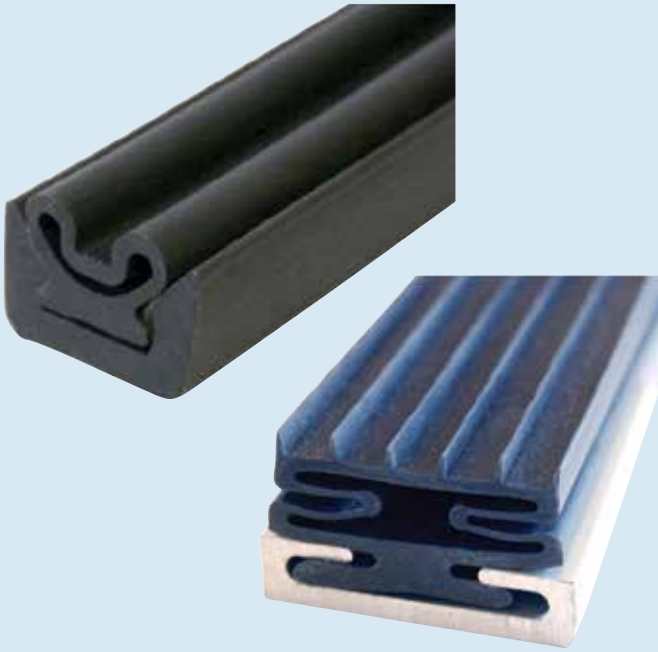

Art.	A	B	D	G	K	S	Hardness SH A
30.0192-2819 *	16	14	1,8	1,8	1,8	4,9	65
30.0192-3161 *	18	15,5	2	2	2	6	60
30.0192-3375 *	18	15,5	2	2	2	2	60
30.0192-3877 *	24	20	2,5	2,5	2,5	5	60
30.0192-4588 *	18,5	17	2	2	2	9	60
30.0192-4633 *	26	20	3	3	3	8,2	60
30.0192-4634 *	35	32	5	5	5	17,6	60
30.0192-4733 *	18,7	18/ 16,6	2	2	2	7,9	60
30.0192-4756 *	16	17	1,5	1,5	1,5	10	60
30.0192-4926 *	27	20	4	4	4	10	60
30.0192-4947 *	22	16	3	3	3	6	60
30.0192-10322 *	30	15	3	3	3	3,7	60
30.0192-10680 *	25,3	20	2,7	2,7	2,7	7,3	60
30.0192-10927 *	26,5	20	3	3	3	9	60
30.0192-10963 *	17	14	2	2	2	5	60
30.0192-11007 *	26	20	3	3	3	8,5	60
30.0192-11016 *	46	34	3	3	5	9	60
30.0192-11484 *	35	34	3	3	3	17	60
30.0192-11800 *	10	10	1,5	2	2	5	60
30.0192-12418 *	45	34	3	3	5	9	60
30.0192-12642 *	21	15	2	2	2	8	60

Art.	A	B	G	H	K	S	Hardness SH A
30.0192-2076 *	16	10	2	10	2,5	1	50
30.0192-2969 *	17	9,5	1,2	8	1,5	1	76
30.0192-3214 *	16	9,5	1,2	8	1,5	1	76
30.0192-3414 *	8,6	8,3	1,2	7,5	1,4	1,2	60
30.0192-3415 *	12	8,5	1,2	7,7	1,4	1,2	60
30.0192-3739 *	17	8,5	1,5	7	2	1	76
30.0192-4792 *	16	7,5	1,2	7	1,5	1	60
30.0192-4906 *	12	8	1,2	6,3	1,5	1,2	60
30.0192-10966 *	30	30,3	4	33,5	9,9	4	60
30.0192-11527 *	17	8,5	1,2	7	1,5	1	60

## Ventil eksempel / Valve example

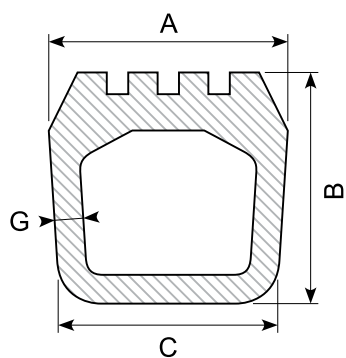

Art.	A	B	C	G	Hardness SH A
30.0192-0374 *	16	20	15	2,5	50
30.0192-0460 *	17	18	17	3,5	50
30.0192-0431 *	34	35	35	5	60
30.0192-0459 *	17	18	15	2,5	50
30.0192-1345 *	16	18	16	2,5	50
30.0192-1494 *	14	11	14	2/2,25	60
30.0192-1744 *	35	33	35	5,5	55
30.0192-1768 *	27	19	27	3,5	50
30.0192-1881 *	36	26,9	36	5	55
30.0192-1949 *	17,5	20	17,5	3	45
30.0192-2029 *	14	14	15,5	2,5	50
30.0192-2067 *	16,5	16	15	2	55
30.0192-2364 *	35	32	35	5	60
30.0192-2408 *	16,5	13	16,5	2,5	55
30.0192-2845 *	14	11	13	2	60
30.0192-3365 *	14	10	14	2	60
30.0192-3497 *	27,5	25	27,5	3	60
30.0192-3551 *	33,5	32	35	5	60
30.0192-3588 *	16	14	16	2	60
30.0192-3616 *	15,5	18	15,5	2	60
30.0192-3693 *	53	41,5	53	5	60
30.0192-3845 *	35	32	35	4	60
30.0192-3900 *	35	32	35	5	60
30.0192-4626 *	34	25	34	5	60
30.0192-4690 *	35	32	35	4,5	60
30.0192-4973 *	15,2	13,6	16,2	2	55
30.0192-10142 *	16	12	16	2,5	60
30.0192-10318 *	35	31	35	4,5	65
30.0192-10358 *	21	24	21	3	60
30.0192-10389 *	16	12	16	2	60
30.0192-10519 *	16	12	16	2	60
30.0192-10947 *	35	32	35	3,3	55
30.0192-11093 *	13,6	10	13,6	2	55
30.0192-11137 *	14	14	14	3	60
30.0192-11278 *	17	9	17	2	55
30.0192-11342 *	32,5	32	35	5	60
30.0192-11385 *	33,5	30	35	5	60
30.0192-11550 *	34	35	35	5	70
30.0192-11937 *	22	20	22	3	60
30.0192-11991 *	33,7	32	33,7	5	60
30.0192-12300 *	35	31,5	35	5	60
30.0192-12398 *	35	35	35	4,3	60
30.0192-12442 *	14	10	14	1,7	50
30.0192-12465 *	35	33	35	4	60

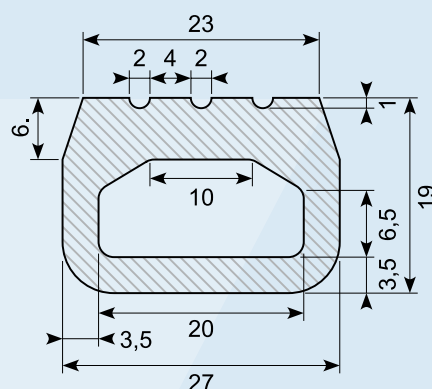
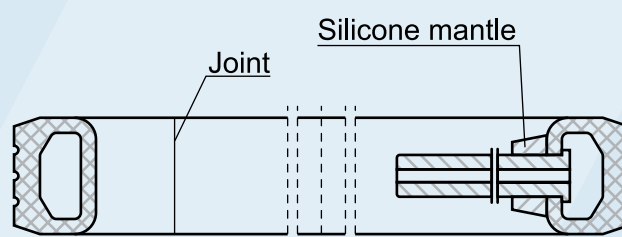
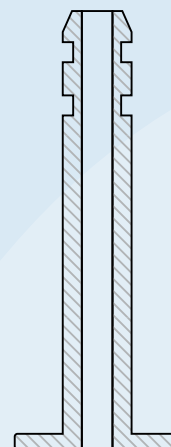

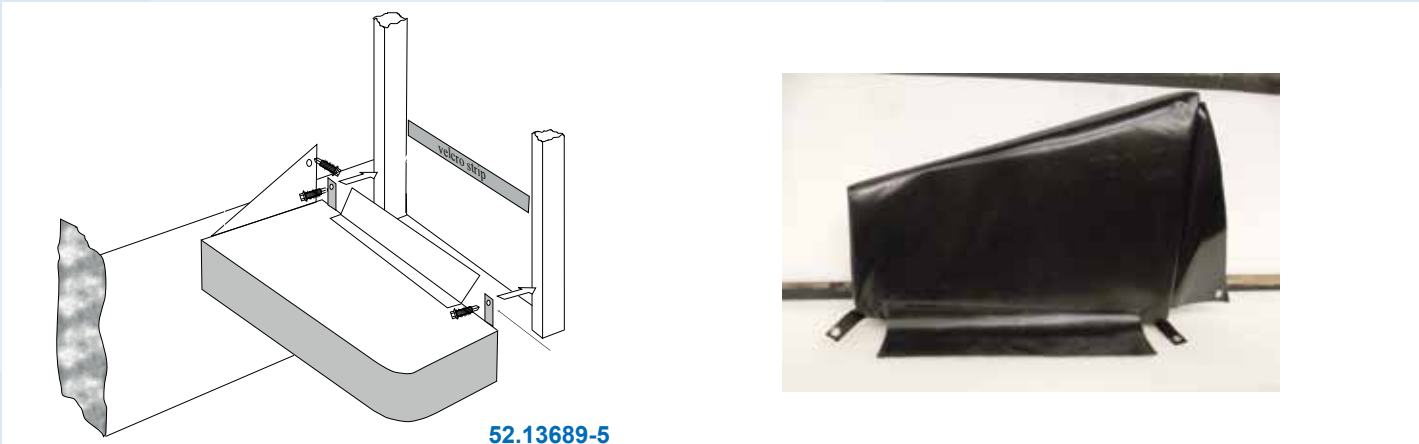
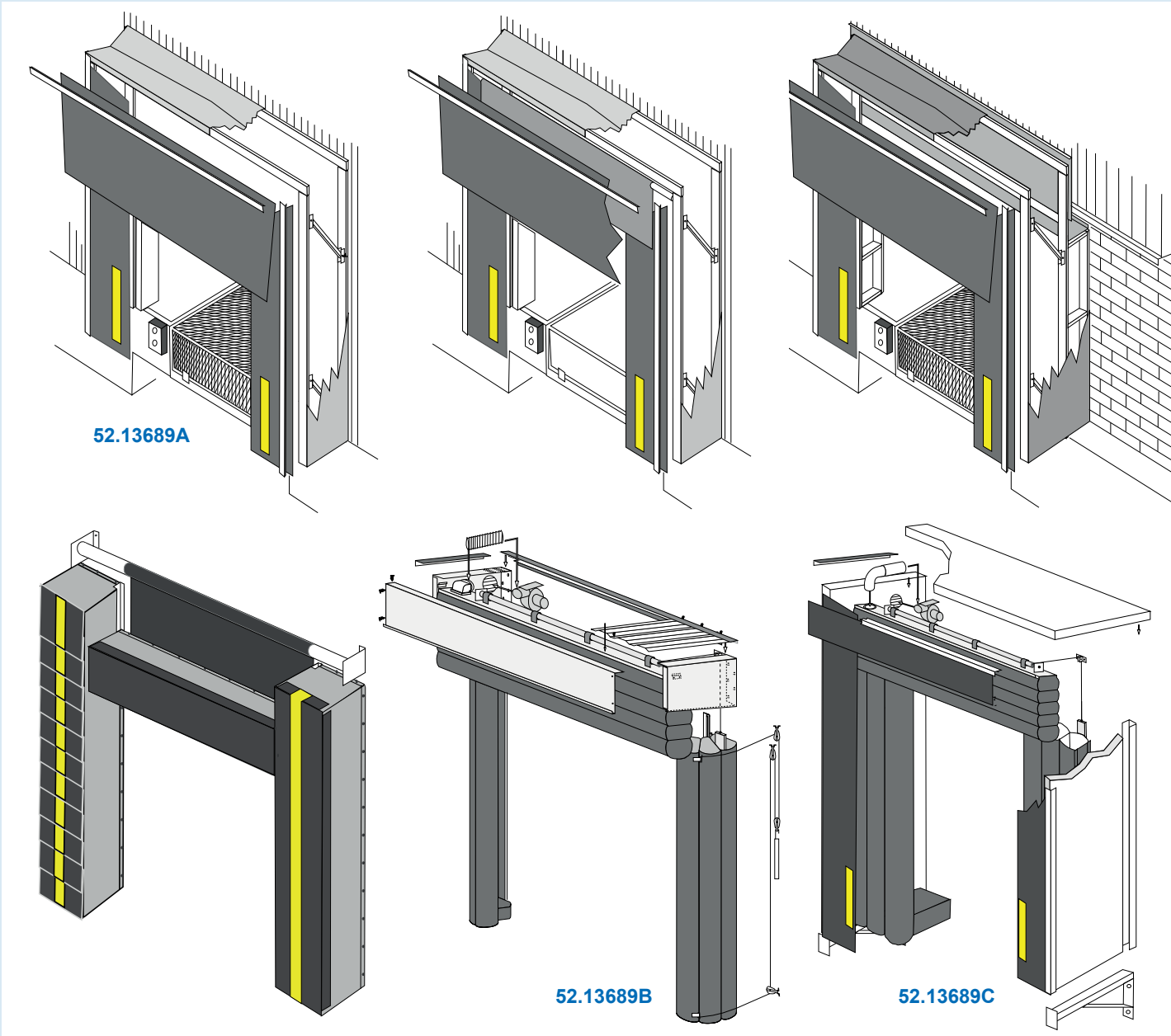

**39.1616 \***



Packer  
750 x 250 x 15 mm  
Weight: 3,6 kg  
Rubber spacer

**39.1617 \***



Packer  
750 x 250 x 20 mm  
Weight: 10,5 kg  
Rubber spacer

**39.1618 \***



Packer  
750 x 250 x 50 mm  
Weight: 10,5 kg  
Rubber spacer

**39.1819 \***



Front plate  
732 x 250 x 62 mm  
Weight: 26 kg  
For buffer [39.649](#)

**39.1620 \***



Back plate for welding  
750 x 250 x 15 mm  
Weight: 24 kg

**39.1621 \***



Back plate. Galvanized  
750 x 250 x 15 mm  
Weight: 24 kg

**39.1622**



Back plate for 450 mm buffer  
720 x 250 x 66 mm  
Weight: 32 kg  
Spring loaded. Follows the truck  
when loading.

**39.1623 \***



Back plate for 750 mm buffer  
965 x 250 x 66 mm  
Weight: 47 kg  
Spring loaded. Follows the truck  
when loading.

**39.1624 \***



Dock bumper accessory  
750 x 250 x 100 mm  
Weight: 17 kg  
Buffer for PE plate

**39.1625 \***



Front plate. Hardwearing PE.  
710 x 210 x 35 mm  
Weight: 4,5 kg

**39.654 \***



Dock bumper L  
750 x 400 x 100 mm  
Weight: 36 kg

**39.655 \***



Dock bumper L  
750 x 400 x 100 mm  
Weight: 36 kg

**39.1626 \***



Front plate. Galvanized  
750 x 400 x 100 mm  
Weight: 36 kg

**39.1627 \***



Front plate. Galvanized  
750 x 400 x 100 mm  
Weight: 36 kg

**39.1628 \***



Back plate. Galvanized  
750 x 400 x 100 mm  
Weight: 34 kg

**39.1629 \***



Back plate. Galvanized  
750 x 400 x 100 mm  
Weight: 34 kg



87.705I



Terokal 2444, 340 g  
Excellent contact adhesive, based on CR, for rubber/rubber - and rubber/metal bonding.

87.727



Terokal 914, 680 g  
Transparent contact adhesive, based on NBR. Very good for PVC.

87.082020



Cyanoacrylate adhesive  
20 g

87.770/10



Loctite 770(7239), 10 g  
Primer which improves the adhesion on materials which are difficult to glue e.g. thermoplastic rubber types. Is to be used together with Loctite 401 / 406 / 431 / 454 or 4850

87.1034



Sicom 50, 3 g  
Excellent for EPDM

87.1035



Sicom 8300, 20 g  
Excellent for sponge rubber

87.1739



Terodicht Elastik, 310 ml  
IK sealant, based on synthetic rubber - black

87.1738



Terodicht schwarz, 310 ml  
IK sealant, based on buthyl rubber - grey

87.2000



Dual component adhesive.  
Total weight: 1 kg

87.52759



Terostat 2759, 310 ml.  
Easy to dab off. IK sealant, based on buthyl rubber. Grey.  
87.52759X: 570 ml

87.51989



Terostat 930, sort 310 ml.  
87.51999F: 570 ml

87.723



Spray glue. Loctite 3923.

30.shore20-90



Shore samples with logo.  
Silicone rubber.

30.shoreA



Shore A hårdhedsmåler  
Shore A hardness tester

30.shoreD



Shore D hårdhedsmåler  
Shore D hardness tester

## Portsluser og tilbehør / Dock shelters

39.1501 \*



Front plate  
440 x 250 x 62 mm  
Weight: 16 kg  
For buffer [39.642X](#)

39.1502 \*



Front plate  
415 x 215 x 62 mm  
Weight: 14 kg  
For buffer [39.643X](#)

39.1503 \*



Back plate for welding  
450 x 250 x 15 mm  
Weight: 15 kg

39.1504 \*



Back plate galvanized  
450 x 250 x 15 mm  
Weight: 15 kg

39.1505 \*



Packer  
450 x 250 x 10 mm  
Weight: 1,3 kg  
Rubber spacer

39.1506 \*



Packer  
450 x 250 x 15 mm  
Weight: 2,3 kg  
Rubber spacer  
Holes as an option

39.1507 \*

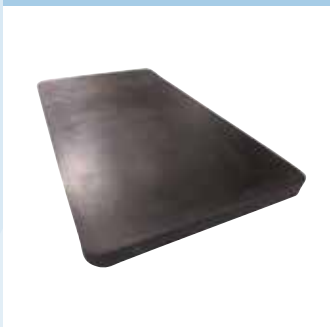

Packer  
450 x 250 x 20 mm  
Weight: 2,8 kg  
Rubber spacer  
Holes as an option

39.1508 \*



Packer  
450 x 250 x 50 mm  
Weight: 5,5 kg  
Rubber spacer

39.1509 \*

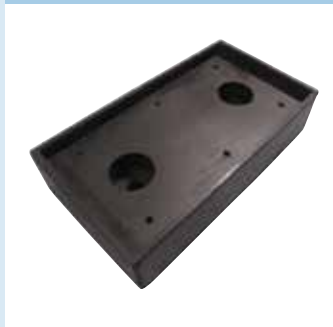

Dock bumper accessory  
450 x 250 x 100 mm  
Weight: 10 kg  
Buffer for PE plate

39.1510 \*



Front plate. Hardwearing PE  
410 x 210 x 35 mm  
Weight: 2,5 kg

39.1511 \*

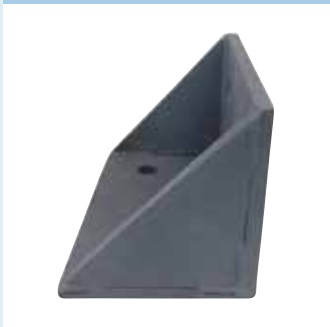

Dock bumper accessory  
250 x 150 x 150 mm  
Weight: 8,1 kg  
For mount of buffer 150 mm over  
ramp level

39.1512 \*



Dock bumper accessory  
250 x 250 x 150 mm  
Weight: 12 kg  
For mount of buffer 150 mm over  
ramp level

39.1513 \*



Front plate  
440 x 440 x 62 mm  
Weight: 13,5 kg

39.1514 \*



Packer  
450 x 450 x 15 mm  
Weight: 2,3 kg  
Rubber spacer for [39.651A](#)

39.1515 \*

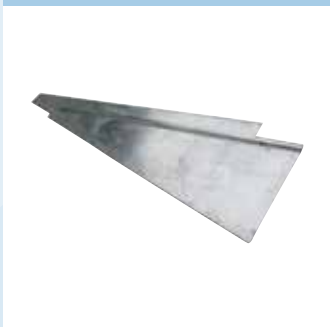

Dock bumper accessory  
1.470 x 540 (max.) x 100 mm  
(min.)  
Weight: 12 kg  
Toe protection

\* Skaffevarer / Special order item

## Portsluser og tilbehør / Dock shelters

39.1630 \*

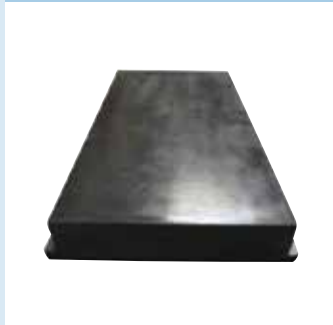

Front plate. Hardwearing rubber  
448 x 248 x 50 mm  
Weight: 7 kg

39.1631 \*



Front plate. Hardwearing PE  
450 x 250 x 50 mm  
Weight: 5 kg

39.1632 \*



Back plate. Galvanized  
450 x 250 x 60 mm  
Weight: 11 kg  
Remember rubber spacer

39.1633 \*



Back plate. Galvanized  
470 x 270 x 120 mm  
Weight: 21 kg  
Remember rubber spacer

39.1634 \*

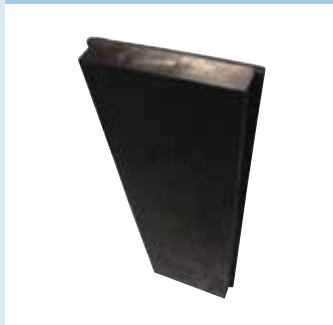

Front plate. Hardwearing rubber  
750 x 250 x 50 mm  
Weight: 12 kg  
Alternative to 39.1635

39.1635 \*



Front plate. Hardwearing PE  
750 x 250 x 50 mm  
Weight: 8 kg

39.1636 \*



Back plate. Galvanized  
770 x 270 x 80 mm  
Weight: 26 kg  
Remember rubber spacer

39.1637 \*



Back plate. Galvanized  
770 x 270 x 120 mm  
Weight: 34 kg  
Remember rubber spacer

39.1638 \*



Trailer plate  
1.000 x 1.000 x 2,5 mm  
Weight: 26,5 kg  
To protect the concrete in front of  
loading ramp

39.1639 \*

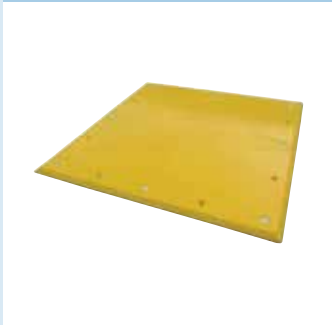

Trailer plate PE  
1.000 x 1.000 x 20 mm  
Weight: 18,5 kg

39.1640 \*

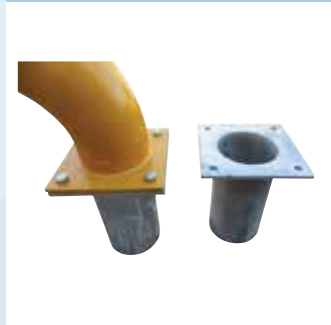

Wheel guide  
Ø165 mm, 5 mm, 300 mm depth.  
Mounting plate: 250 x 250 x 10  
mm.  
Weight: 8,5 kg

39.1641 \*



Wheel guide  
Ø165 mm, 5 mm, 2.085 x 250 x  
365 mm.  
Color: Yellow RAL 1028  
Weight: 90 kg  
\* Skaffevare / Special order item

39.1642 \*



Wheel guide  
Ø165 mm, 5 mm, 2.070 x 600 x  
365 mm. Yellow RAL 1028.  
Weight: 90 kg  
Can be ordered in hot-dipped.

39.1643 \*



Wheel guide  
2.070 x 250 x 200 mm  
Color: Yellow RAL 1028  
Weight: 78 kg

39.1644 \*



Wheel guide. Hot dipped.  
Ø165 mm, 5 mm, 3.000 x 600 x  
365 mm

S10.3301



Dolphin knife

S10.3303



10 pcs. blades for S10.3301

S10.3311



Utility knife

S10.3313



10 pcs. blades for S10.3311

S10.3312



Utility knife

S10.3314



10 pcs. blades for S10.3312

83.842



Profile cutter

84.930



Tool set for inserting filler sections in glazing sections. Eyelet Ø 9,5 mm.

84.931



Tool for filler sections

84.932T



Tool for glazing sections with wooden handle

84.934X



7 mm eyelet for 84.931

84.934



9,5 mm eyelet for 84.931

84.935



10,5 mm eyelet for 84.931

84.840084



Cold cut knife

84.961



Cold cut knife blade for 84.840084. 19 mm.

84.961A: 25 mm

84.961B: 35 mm

Dimensional tolerances for moulded, extruded and calendered solid rubber products.  
(GB/T 3672-92) ISO3302-1998

Rubber thickness (mm)	E1 ± (mm)	E2 ± (mm)	E3 ± (mm)
0 - 1,5	0,15	0,25	0,4
1,5 - 2,5	0,2	0,35	0,5
2,5 - 4	0,25	0,4	0,65
4 - 6,3	0,35	0,5	0,8
6,3 - 10	0,4	0,65	1
10 - 16	0,5	0,8	1,3
16 - 25	0,65	1	1,6
25 - 40	0,8	1,3	2
40 - 63	1	1,6	2,5
63 - 100	1,3	2	3,2

## Edge trims

Configure your own edge trim or choose from the 2.000 different we have in stock.

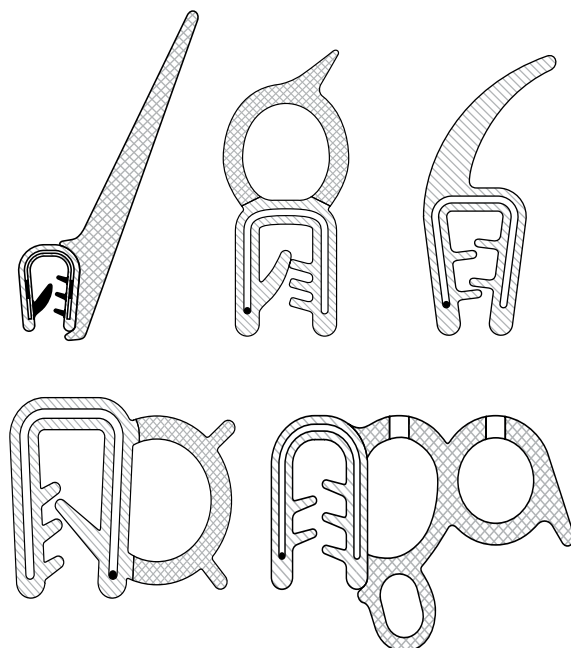
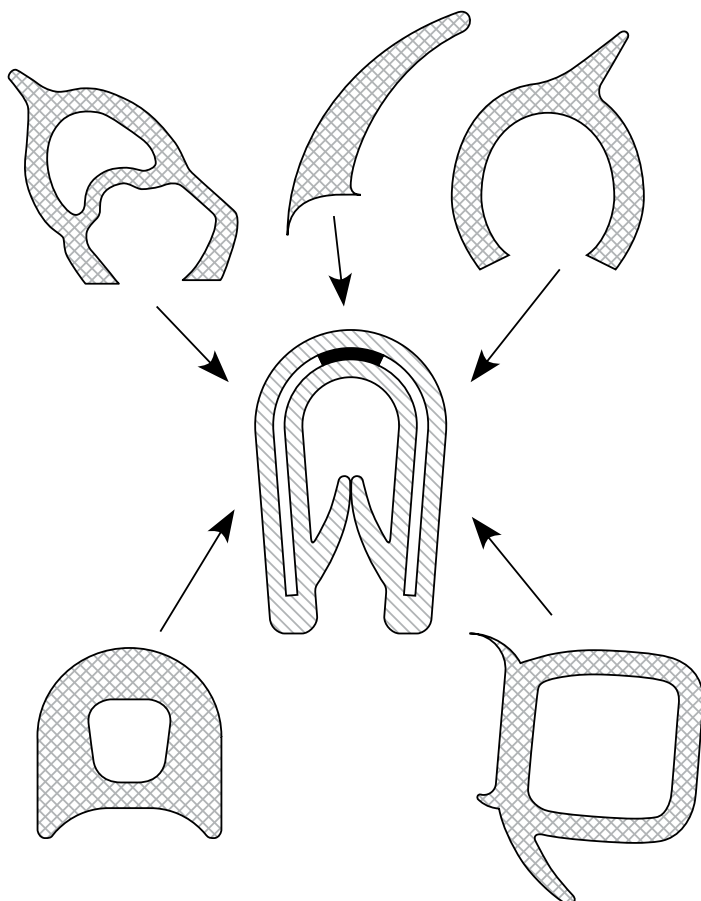









## Varenummerindex / product number index

Vare Art	Side Page	Vare Art	Side Page	Vare Art	Side Page	Vare Art	Side Page	Vare Art	Side Page	Vare Art	Side Page
38.428	82	39.1644	104	39.4178	70	39.AV2024	69	39.D100/30	68	39.E50/20	67
38.429-2	86	39.167G	59	39.4224	71	39.AV30	69	39.D100/50	68	39.E50/25-M12	67
38.430-10/70	93	39.168G	59	39.4229	71	39.AV5068	69	39.D100/75	68	39.E50/25	67
38.430-10/90	93	39.169G	59	39.4244	71	39.AV50	69	39.D15/10-M6	65	39.E50/40-M12	67
38.430-5/70	93	39.170G	59	39.4249	71	39.AV9580	69	39.D15/10	65	39.E50/40	67
38.430-5/80	93	39.171G	59	39.4250	71	39.B100/30	68	39.D15/15-M6	65	39.E60/30-M12	67
38.430-8/70	93	39.171J	59	39.4251	71	39.B100/40	68	39.D15/15	65	39.E60/30	67
38.430-8/90	93	39.172	59	39.4257	71	39.B100/50	68	39.D150/50	68	39.E60/40-M12	67
38.440-6	92	39.173	60	39.4269	71	39.B100/75	68	39.D20/15E	65	39.E60/40	67
38.440-6A	92	39.174	59	39.4310	71	39.B16/18	65	39.D20/20-M6	65	39.E70/35	67
38.440-8	92	39.175H	59	39.4311	71	39.B20/10-M6	65	39.D20/20	65	39.E70/50	67
38.440-8A	92	39.175J	59	39.4333	70	39.B20/10	65	39.D200/100	68	39.E75/30-M12	68
38.440-8X	92	39.177	59	39.4380	71	39.B20/15	65	39.D30/10-M6	66	39.E75/30	68
38.449-1200	93	39.178	59	39.4380X	70	39.B2020	65	39.D30/10	66	39.E75/50-M12	68
38.449-750	93	39.179	59	39.4381	71	39.B25/25-M6	66	39.D30/15-M6	66	39.E75/50	68
38.450-760	93	39.180	63	39.4399	70	39.B25/25	66	39.D30/15	66	39.E80/50-M16	68
38.451-1600	93	39.181052	60	39.4403	71	39.B2513	65	39.D30/20-M6	66	39.E80/50	68
38.452-1200	93	39.181052	62	39.500500A	72	39.B30/20	66	39.D30/20	66	39.KD25/17	69
38.5017530	89	39.181060	60	39.55	71	39.B30/20X	66	39.D30/30-M6	66	39.KD50/18	69
38.5017530	89	39.181060	62	39.56	71	39.B30/30-M6	66	39.D30/30	66	39.KD50/50	69
38.5501110	91	39.181061	60	39.57	71	39.B30/30	66	39.D40/15-M6	66	39.KP-D10/10	69
38.5501210	91	39.181061	62	39.620J	60	39.B40/20	66	39.D40/15	66	39.KP-D115/136	69
38.5501310	91	39.181	63	39.623J	60	39.B40/30	66	39.D40/20-A2	66	39.KP-D118/77	69
38.623750	91	39.1819	103	39.624	60	39.B40/35	66	39.D40/20-M10	66	39.KP-D15/22	69
38.623752	91	39.182	63	39.625	60	39.B50/21	67	39.D40/20-M6	66	39.KP-D20/15	69
38.623764	91	39.183	63	39.626J	60	39.B50/30	67	39.D40/20	66	39.KP-D25/16	69
38.8100110	88	39.183A	63	39.627	60	39.B50/50-M10	67	39.D40/25-A2	66	39.KP-D25/20	69
38.8100310	88	39.183B	63	39.628	60	39.B50/50	67	39.D40/30-A2	66	39.KP-D30/30	69
38.8103110	88	39.183C	63	39.629	60	39.B60/30	67	39.D40/30-M8	66	39.KP-D30/36	69
38.9110030	90	39.184	63	39.630	61	39.B60/40	67	39.D40/30	66	39.KP-D50/58	69
38.9117630	90	39.185	63	39.631A	61	39.B75/30	68	39.D40/35-A2	66	39.KP-D50/61	69
38.9117631	90	39.186	63	39.631X	61	39.B75/40	68	39.D40/35	66	39.KP-D50/67	69
38.9716230	90	39.187	63	39.632A	59	39.B75/50	68	39.D40/40-A2	66	39.KP-D60/40	69
38.9726230	88	39.188	63	39.632B	59	39.BUMPER	97	39.D40/40	66	39.KP-D70/58	69
38.9730030	88	39.200200	72	39.632C	59	39.BUMPERB	97	39.D40/45-A2	66	39.KP-D70/60	69
38.9730030S	88	39.2486	70	39.632J	59	39.BUMPERC	97	39.D50/20-M12	67	39.KP-D75/89	69
38.9750030	88	39.2776	71	39.634	61	39.BUMPERD	97	39.D50/20	67	39.KP-E10/10	69
38.9971010	93	39.300300	72	39.634P	61	39.BUMPERE	97	39.D50/25-M12	67	39.KP-E115/136	69
38.9971020	93	39.300300A	72	39.635	62	39.C100/40	68	39.D50/25	67	39.KP-E118/77	69
39.103195	69	39.300300FK	72	39.635X	62	39.C100/50	68	39.D50/30-M10	67	39.KP-E15/22	69
39.1208P	20	39.3010	70	39.636	62	39.C100/75	68	39.D50/30	67	39.KP-E20/15	69
39.1501	102	39.3023	71	39.636H	62	39.C150/40	68	39.D60/30-M12	67	39.KP-E20/24	69
39.1502	102	39.3029	71	39.636X	62	39.C150/50	68	39.D60/30	67	39.KP-E25/16	69
39.1503	102	39.3051	71	39.637	60	39.C150/75	68	39.D60/40-M12	67	39.KP-E25/20	69
39.1504	102	39.3240	70	39.638	60	39.C20/10	65	39.D60/40	67	39.KP-E30/30	69
39.1506	102	39.3366	71	39.642X	61	39.C20/20	65	39.D6050	67	39.KP-E30/36	69
39.1507	102	39.3381	71	39.643X	61	39.C200/100	68	39.D65/35	67	39.KP-E35/40	69
39.1508	102	39.3428	71	39.644	61	39.C25/10	65	39.D70/40-M12	67	39.KP-E50/50	69
39.1509	102	39.3581	71	39.645	64	39.C25/15	66	39.D70/40	67	39.KP-E50/61	69
39.1510	102	39.360	60	39.646	60	39.C25/25-M6	66	39.D70/70	67	39.KP-E50/67	69
39.1511	102	39.36412	71	39.647	61	39.C30/20	66	39.D75/30	68	39.KP-E50/68	69
39.1512	102	39.3700	71	39.648	61	39.C30/30	66	39.D75/50-M10	68	39.KP-E60/40	69
39.1513	102	39.3722	70	39.649	61	39.C40/25	66	39.DC300300	74	39.KP-E70/58	69
39.1514	102	39.3726	71	39.650	61	39.C40/30	66	39.DD300300	73	39.KP-E70/60	69
39.1515	102	39.3802	71	39.651A	61	39.C40/40-M10	66	39.E100/25	68	39.KP-E75/89	69
39.1616	103	39.3803	71	39.652	61	39.C40/40	66	39.E100/30	68	39.KP-E95/80	69
39.1617	103	39.3803X	70	39.653	61	39.C50/20	67	39.E100/40	68	39.M1810	65
39.1618	103	39.3813	71	39.654	103	39.C50/25	67	39.E100/50	68	39.M20/10-M6	65
39.1620	103	39.3815	71	39.655	103	39.C50/30-68	67	39.E100/75	68	39.M20/10	65
39.1621	103	39.3846	70	39.656	62	39.C50/30-M8	67	39.E150/50-M20	68	39.M2015	65
39.1622	103	39.3849	71	39.657	62	39.C50/30	67	39.E150/50	68	39.M2020-M8	65
39.1623	103	39.3868	70	39.658	62	39.C50/35	67	39.E150/75-M20	68	39.M2020	65
39.1624	103	39.3872	70	39.659	62	39.C50/40-M12	67	39.E150/75	68	39.M24	61
39.1625	103	39.3873	70	39.660	62	39.C50/40	67	39.E20/10-M6	65	39.M2515	66
39.1626	103	39.3874	70	39.661	62	39.C50/45	67	39.E20/10	65	39.M2520-M6	66
39.1627	103	39.3875	70	39.662	62	39.C60/30-M8	67	39.E200/100	68	39.M2520	66
39.1628	103	39.3876	70	39.663	62	39.C60/30	67	39.E25/10-M6	65	39.M30/10	66
39.1630	104	39.3878	71	39.664	62	39.C60/40-M10	67	39.E25/10	65	39.M3015-M8x12	66
39.1631	104	39.3879	71	39.665	62	39.C60/40-M12	67	39.E30/15-M6	66	39.M3015-M8x15	66
39.1632	104	39.3887	70	39.674	70	39.C60/40	67	39.E30/15	66	39.M3020-55	66
39.1633	104	39.3904X	70	39.678	70	39.C65/35-M10	67	39.E30/20-M6	66	39.M3020	66
39.1634	104	39.3923	71	39.678X	70	39.C65/35	67	39.E30/20	66	39.M3030-SS	66
39.1635	104	39.3925	71	39.680H-1180	70	39.C70/45-M10	68	39.E30/30-M6	66	39.M3030	66
39.1636	104	39.3952	71	39.680H	70	39.C75/100-M16	68	39.E30/30	66	39.M40/20	66
39.1637	104	39.4012	71	39.680X	70	39.C75/100	68	39.E30/35	66	39.M40/40	66
39.1638	104	39.4025	66	39.684X	70	39.C75/30-M10	68	39.E40/15-SH43	66	39.M4030	66
39.1639	104	39.4054	71	39.684XS	70	39.C75/30	68	39.E40/20-M6	66	39.M4038	66
39.1640	104	39.4087	70	39.685	70	39.C75/55-43	68	39.E40/20	66	39.M5025	67
39.1641	104	39.4110	71	39.69	71	39.C75/55-M10	68	39.E40/30	66	39.M5030	67
39.1642	104	39.4129	71	39.79	71	39.C75/55	68	39.E50/20-M10	67	39.M5040	67
39.1643	104	39.4156	70	39.93	71	39.D10/10	65	39.E50/20-M12	67	39.M5045	67

## Varenummerindex / product number index

Vare Art.	Side Page	Vare Art.	Side Page	Vare Art.	Side Page	Vare Art.	Side Page
39.M5050	67	48.621	80	50.266	95	79.051	96
39.M6035	67	48.622	80	50.267	96	79.051A	96
39.M6050	67	48.622X	80	50.267NR	96	79.052	96
39.M7540	68	48.623	80	50.269	96	79.053	96
39.M7550	68	48.623X	80	50.271	95	79.054	96
39.M7560	68	48.624	80	50.275	95	79.055	96
39.M8050	68	48.626	79	50.276	95	83.842	105
39.SC300300	74	48.634	79	50.280	96	84.840084	105
39.SD300250	73	48.634F	79	52.13689-5	101	84.930	105
39.SD300300	73	48.634K	79	52.13689A	101	84.931	105
41.13459	28	48.634KF	79	52.13689B	101	84.932T	105
41.13459X	28	48.635	79	52.13689C	101	84.934	105
41.333S	20	48.635F	79	52.269	38	84.934X	105
41.670	28	48.635K	79	52.269X	38	84.935	105
41.674A	20	48.635KF	79	52.CWC8	63	84.961	105
41.675A	20	48.636	79	52.PP106	27	87.082020	106
41.678	20	48.636F	79	54.261700J-5	98	87.1034	106
45.102G	57	48.636FX	79	54.261700JC-5	98	87.1035	106
45.123	58	48.636K	79	54.261700JD-5	98	87.1738	106
45.2031024	58	48.636KF	79	54.261700JX-5	98	87.1739	106
45.20511046	58	50.083000GG	32	54.261720J-5	98	87.2000	106
45.20511091	58	50.083000SS	32	54.261740J-5	98	87.51989	106
45.2051445	58	50.083013	30	54.261760J-5	98	87.52759	106
45.205S	29	50.083015GG	30	54.261780J-5	98	87.705L	106
45.205SX	29	50.083015GGX	30	54.710290	25	87.723	106
45.206AL	56	50.083030	30	54.710720	30	87.727	106
45.208	29	50.083032GG	30	54.710770	31	87.770/10	106
45.209BX	29	50.083033	30	54.710780	32	D-fender	72
45.210B	29	50.083033X	30	57.400/1	76	D-fender	72
45.210BX	29	50.083040	30	57.400/2	76	D-fender	72
45.210C	29	50.083040G	30	57.400/3	76	DC-fender	74
45.210CX	29	50.083040GG	30	57.401/1	76	DD-fender	73
45.216C-50	57	50.083040GS	30	57.401/2	76	Keyhole fender	75
45.217C	56	50.083045G	30	57.401/3	76	KF-A-fender	75
45.221C	56	50.083045X	30	57.402/1	76	KF-B-fender	75
45.224	56	50.083050	30	57.402/2	76	KF-C-fender	75
45.235N1057	58	50.083050G	30	57.402/3	76	KF-D-fender	75
45.235N429	58	50.083050GG	30	57.403/1	76	MC-fender	75
45.235NG1057	58	50.083052G	31	57.403/2.5J	77	S10.3301	105
45.235NG429	58	50.083055G	31	57.403/2	76	S10.3303	105
45.308C-50	57	50.083059	31	57.403/3	76	S10.3311	105
45.308C	57	50.083060	31	57.404/1	76	S10.3312	105
45.309C-50	57	50.083060G	31	57.404/2	76	S10.3313	105
45.309C	57	50.083061	31	57.404/3	76	S10.3314	105
45.347C	56	50.083065	31	57.405/1	76	SC-fender	74
45.383C	56	50.083065G	31	57.405/2	76	SD-fender	73
45.388C	56	50.083070B	31	57.405/2J	77	Wing-type-fender	75
45.393	58	50.083070G	31	57.405/3	76		
45.394	58	50.083080G	31	57.406/1	76		
45.705C	56	50.083080GG	31	57.406/2	76		
45.832	56	50.083081	31	57.406/3	76		
45.836	56	50.083088	31	57.407/1	76		
45.837	56	50.083089	31	57.407/2	76		
45.839	56	50.083090	32	57.407/3	76		
45.872	56	50.083095	32	57.440/1	76		
45.874	56	50.083095B	32	57.440/2	76		
45.882	56	50.083095G	32	57.440/3	76		
45.884C	56	50.13621	96	57.441/1	76		
45.886	57	50.241NR	95	57.441/2	76		
45.886G	57	50.242NR	95	57.441/3	76		
45.894	57	50.243NR	96	57.442/1	76		
45.901	58	50.244NR	95	57.442/2	76		
45.980A	57	50.245H	95	57.442/3	76		
45.980K	57	50.245NR	95	57.443/1	76		
45.980S	57	50.246-10	95	57.443/2	76		
48.442	81	50.246NR	95	57.443/2JP	77		
48.451	80	50.247-10	95	57.443/3	76		
48.452	80	50.247NR	95	57.444/1	76		
48.542	81	50.250	96	57.444/2	76		
48.544A	81	50.260-10	18	57.444/3	76		
48.603	79	50.260-4	18	57.445/1	76		
48.604	79	50.260-5	18	57.445/2	76		
48.605	80	50.260-6	18	57.445/3	76		
48.605B	80	50.260-8	18	57.446/1	76		
48.605X	80	50.261	96	57.446/2	76		
48.605Y	80	50.263	96	57.446/3	76		
48.608	80	50.263K	96	57.447/1	76		
48.609	80	50.264-10	95	57.447/2	76		
48.612	81	50.264	96	57.447/3	76		
48.613K	79	50.265-10	95	63.55030	81		
48.618	81	50.265	95	68.4250	81		

Kemisk betegnelse	Natur-kautsjuk	Styrolbutadien-Kausjuk	Nitril kausjuk (Perbunan)	Chlororen kausjuk (Neopren)	Ethylen propylen kausjuk (APTK)
Chemical Nomenclature	Naturel Rubber	Styrol Butadien Rubber (Buna)	Nitril Rubber (Perbunan)	Chloroprene Rubber (Neoprene)	Ethylene Propylene Dien Rubber
Navnefortegnelse i.h.t. ASTM D 1418 Abbreviation as per ASTM D 1418	NR	SBR	NBR	CR	EPDM
Hårdhedsområde (Shore A)(±5) Hardness Range (Shore A)(±5)	40 - 90	45 - 90	45 - 90	40 - 90	40 - 90
Trækstyrke N/mm <sup>2</sup> Tensile Strength N/mm <sup>2</sup>	4 - 15	4 - 15	4 - 14	5 - 15	6 - 13
Tilbagestødselasticitet ved 20°C Recoil Elasticity at 20°C	Udmærket Excellent	God Good	Tilfredsstillende Satisfactory	God Good	God Good
Slidstyrke Abrasion Resistance	Meget god Very good	Meget god Very good	God Good	God Good	God Good
(1) Kemisk bestandighed (1) Chemical Resistance	God Good	God Good	Tilfredsstillende Satisfactory	God Good	Meget god Very good
(1) Oliebestandighed (1) Oil Resistance	Ringe Low	Ringe Low	Udmærket Excellent	God Good	Ringe Low
(1) Bestandighed overfor benzin (1) Petrol Resistance	Ingen None	Ringe Low	God Good	Ringe Low	Ringe Low
(1) Bestandighed overfor opløsningsmidler (1) Solvent Resistance	Ringe Low	Ringe Low	God Good	God Good	(3) Tilfredsstillende (3) Satisfactory
(4) Temperaturbestandighed °C (4) Temperature Stability in °C	-40 til +80° -40 to +80°	-30 til +80° -30 to +80°	-30 til +100° -30 to +100°	-25 til +100° -25 to +100°	-40 til +100° -40 to +100°
Ozonbestandighed Ozone Resistance	Tilfredsstillende Satisfactory	Tilfredsstillende Satisfactory	Tilfredsstillende Satisfactory	Meget god Very good	Udmærket Excellent
Vejrbestandighed General Climate Resistance	God Good	God Good	God Good	Meget god Very good	Udmærket Excellent
Gasuigennemtrængelighed Gas Impermeability	Tilfredsstillende Satisfactory	Tilfredsstillende Satisfactory	God Good	God Good	Tilfredsstillende Satisfactory
(2) Modstand mod blivende deformationer (2) Resistance to permanent set	Meget god Very good	God Good	God Good	God Good	God Good
Bindekraft til metal Adhesion to metal	Udmærket Excellent	Meget god Very good	Tilfredsstillende Satisfactory	God Good	Tilfredsstillende Satisfactory
Bindekraft til tekstiler Adhesion to textile	Udmærket Excellent	God Good	Tilfredsstillende Satisfactory	Udmærket Excellent	Tilfredsstillende Satisfactory

(1) = På grund af mange mulige kemikalier, opløsningsmidler, arbejdstemperaturer og arbejdstider kan de oplyste værdier, i enkelte tilfælde, udvise forandringer. Især kan en elastomeretype, som normalt udviser ringe bestandighed, udvise en meget god resistens overfor bestemte medier.

(2) = Ved relative lave h.h.v. høje temperaturer reduceres modstanden normalt.

(3) = God udvidelsesbestandighed overfor forskellige blødgørere.

(4) = Det drejer sig om grænseværdier, som kan svinge alt efter sammensætningen af blandingen. Vedvarende indsætning i grænseområderne ændrer de fysiske værdier. Til ekstreme påvirkninger kræves særlige elastomere-blandinger.

(1) = In view of the multitude of chemicals, solvents, application temperatures and times the value quoted may vary in some cases. For example one type of elastomer which normally has only low resistance properties could show very good resistance to certain media.

(2) = At relatively high or low temperatures, resistance generally drops.

(3) = Good expansion resistance to various ester based plasticizers.

(4) = These are borderline values which, depending on composition of the mixture, can vary. If used permanently in such borderline areas, this can lead to a change in the physical values. For such extreme applications it is advisable to use special elastomer mixtures.

ENGINEERING  
LOGISTICS  
SERVICE

**SINDBY**  
A BIBUS GROUP COMPANY

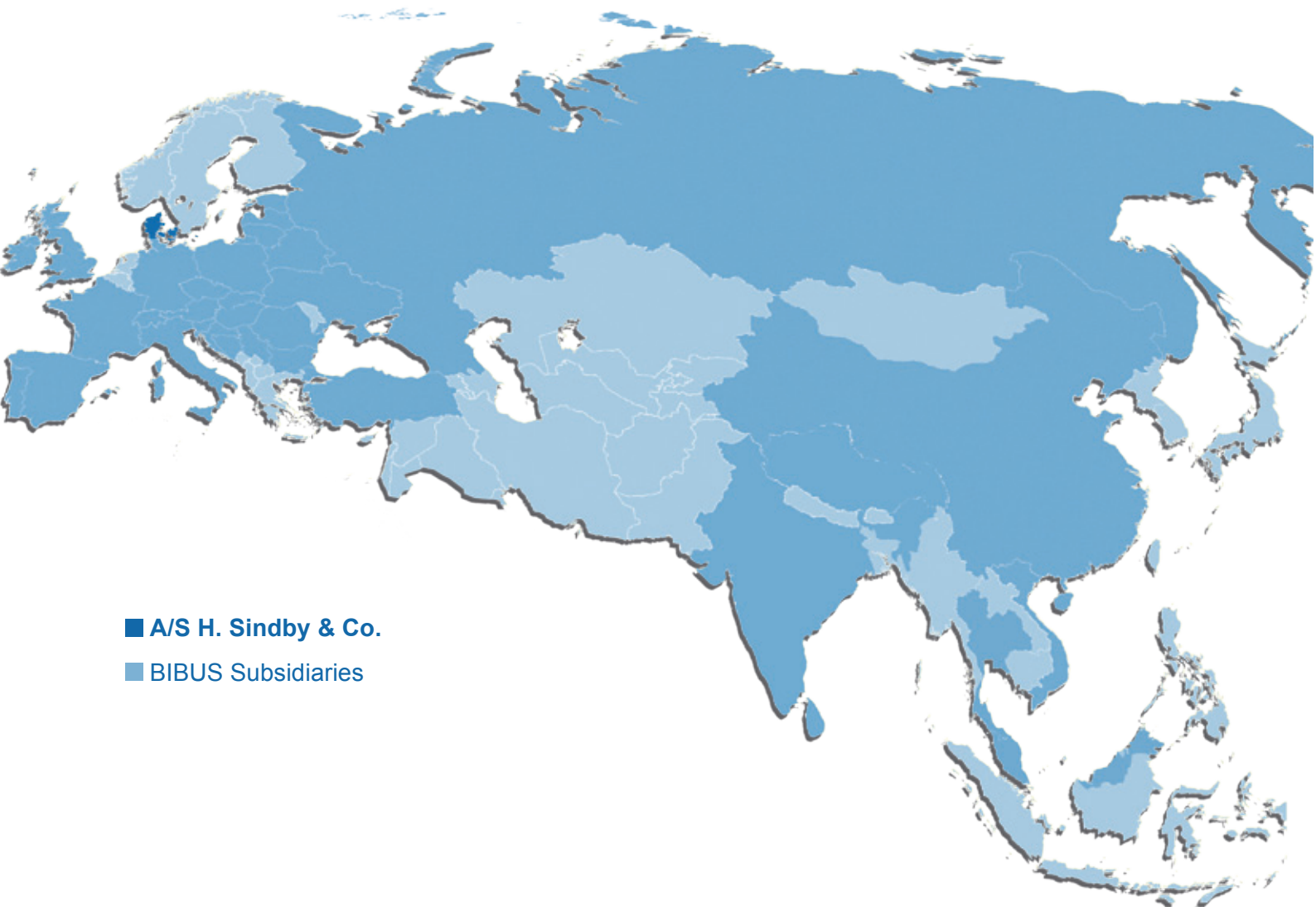

■ A/S H. Sindby & Co.  
■ BIBUS Subsidiaries

**A/S H. Sindby & Co.**  
Edisonvej 11  
DK-7100 Vejle  
Tel. +45 75 88 21 22  
Fax +45 75 88 21 21  
sindby@sindby.dk

**BIBUS**<sup>®</sup>  
SUPPORTING YOUR SUCCESS

BIBUS SK, s.r.o  
Trnavská 31, SK-94 901 Nitra

Tel.: 037/ 7777 911    Email: sale@bibus.sk  
Fax.: 037/ 7777 999    http://www.bibus.sk