

## 32.016S

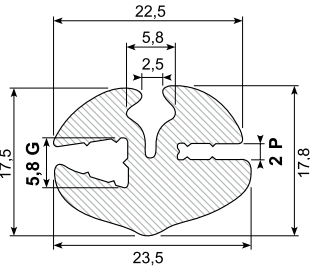

Material: EPDM black  
Hardness: SH 65  
Min. radius: 90 mm

## 32.924 \*\*

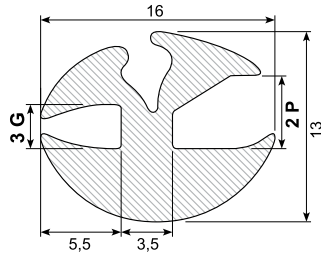

Material: EPDM black  
Hardness: SH 60  
Min. radius: 30 mm  
Incl. wedge

## 32.2024CR \*

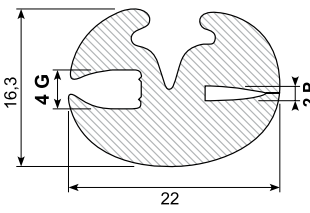

Material: CR black  
Hardness: SH 65  
Min. radius: 80 mm  
Min. order: 200 m  
Oil resistant

## 32.1024S

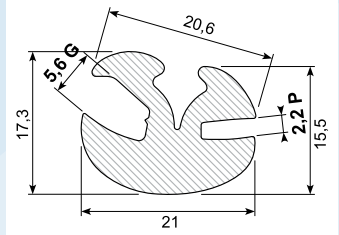

Material: EPDM black  
Hardness: SH 65  
Min. radius: 80 mm

## 32.1025S

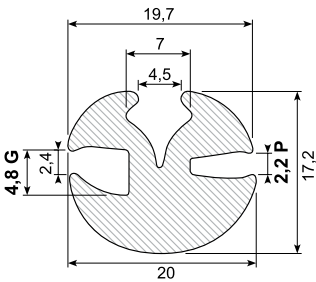

Material: EPDM black  
Hardness: SH 65  
Min. radius: 80 mm

## 32.2024M

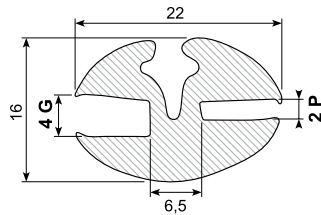

Material: EPDM black  
Hardness: SH 65  
Min. radius: 80 mm

## 32.1025SK

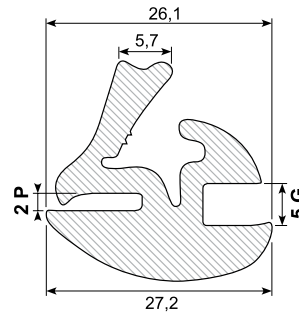

Material: EPDM black  
Hardness: SH 65  
Min. radius: 80 mm  
Incl. wedge

## 32.034S

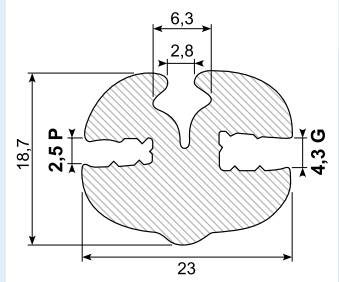

Material: EPDM black  
Hardness: SH 65  
Min. radius: 90 mm

## 32.036S

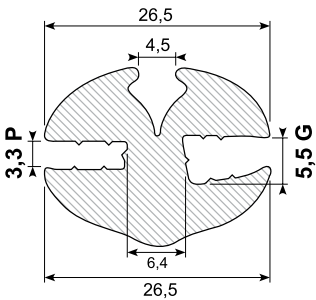

Material: EPDM black  
Hardness: SH 65  
Min. radius: 75 mm

## 32.1045SK \*

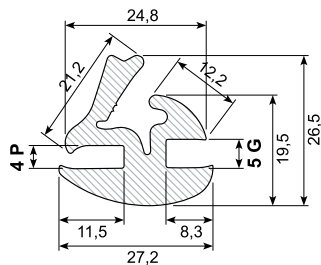

Material: EPDM black  
Hardness: SH 65  
Min. radius: 80 mm  
Incl. wedge  
Min. order: 100 m

## 32.044S

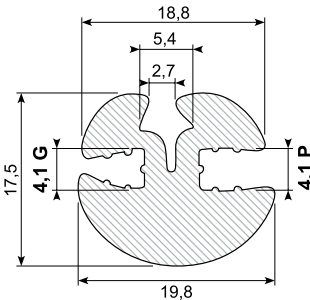

Material: EPDM black  
Hardness: SH 65  
Min. radius: 75 mm

## 32.046S

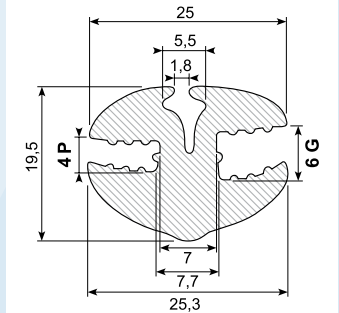

Material: EPDM black  
Hardness: SH 65  
Min. radius: 90 mm

## 32.2045M

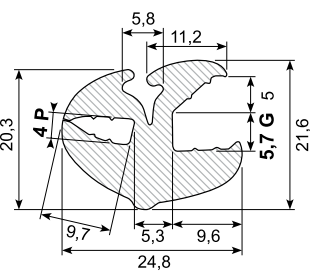

Material: EPDM black  
Hardness: SH 65  
Min. radius: 90 mm

## 30.8439

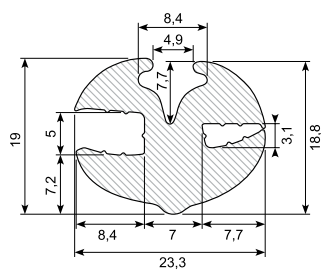

Material: EPDM  
Hardness: SH 65

## 32.036X

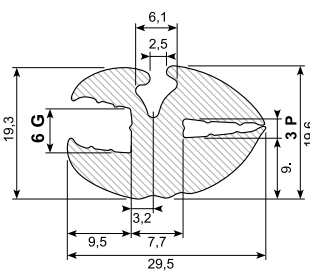

Material: EPDM  
Hardness: SH 65

## 32.047

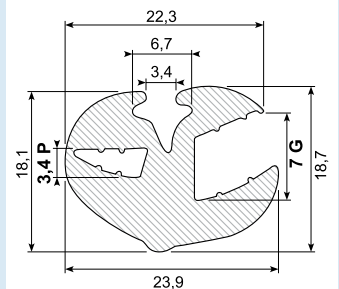

Material: EPDM black  
Hardness: SH 65  
Min. radius: 90 mm

32.1045S

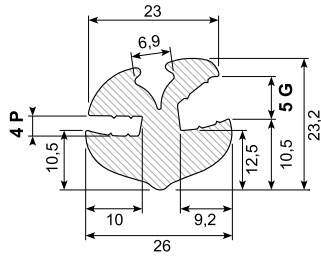

Material: EPDM black  
Hardness: SH 65  
Min. radius: 90 mm

32.057 \*

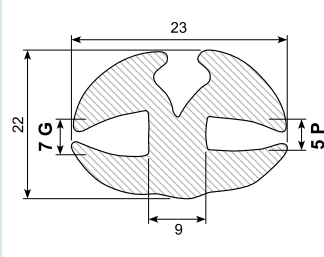

Material: EPDM black  
Hardness: SH 65  
Min. radius: 100 mm  
Min. 300 m

32.255S

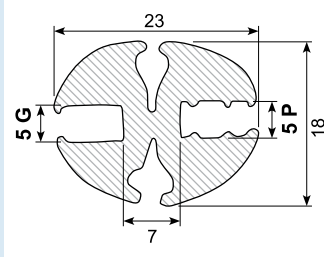

Material: EPDM black  
Hardness: SH 65  
Min. radius: 100 mm

32.064S

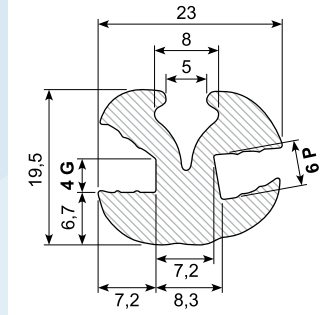

Material: EPDM black  
Hardness: SH 70

32.066

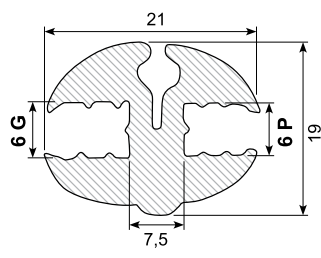

Material: EPDM black  
Hardness: SH 65  
Min. radius: 80 mm

32.075

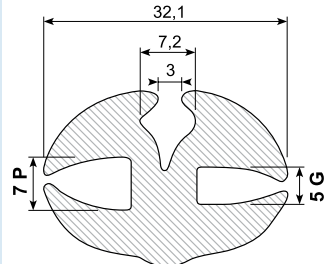

Material: EPDM black  
Hardness: SH 65  
Min. radius: 100 mm

32.095S

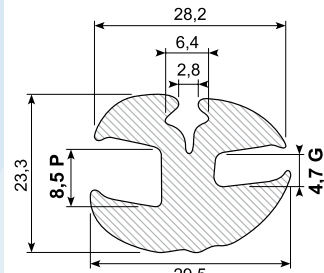

Material: EPDM black  
Hardness: SH 65  
Min. radius: 115 mm

32.512

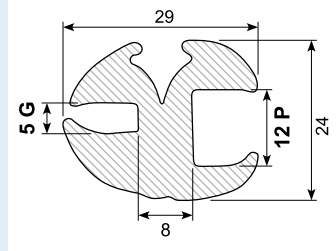

Material: EPDM black  
Hardness: SH 65  
Min. radius: 115 mm

32.165

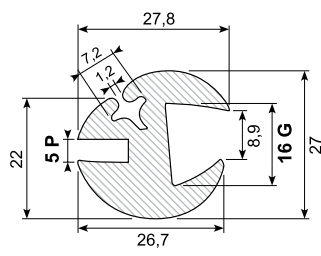

Material: EPDM black  
Hardness: SH 65  
Min. radius: 120 mm

32.514S

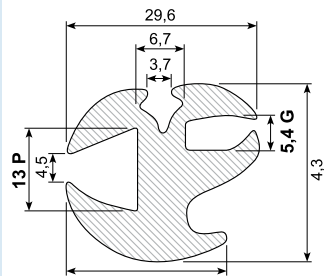

Material: EPDM black  
Hardness: SH 65  
Min. radius: 110 mm

32.516S

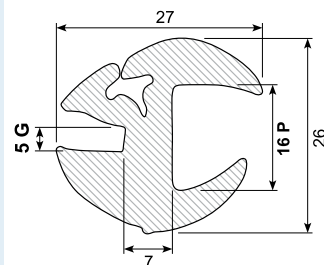

Material: EPDM black  
Hardness: SH 65  
Min. radius: 120 mm

32.523S

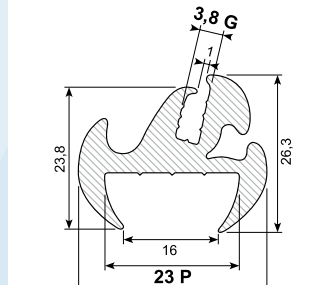

Material: EPDM black  
Hardness: SH 65  
Min. radius: 110 mm

32.527

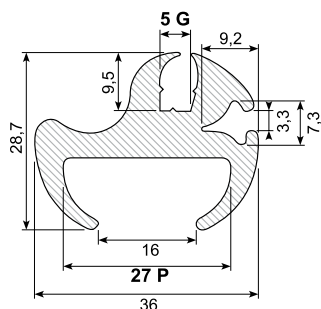

Material: EPDM black  
Hardness: SH 65  
Min. radius: 120 mm

32.1037S

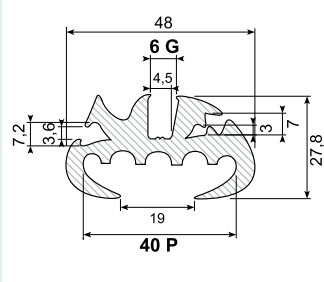

Material: EPDM black  
Hardness: SH 65  
Min. radius: 120 mm

32.1640

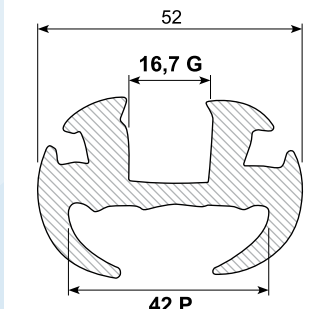

Material: EPDM black  
Hardness: SH 65  
Min. radius: 120 mm

32.754S

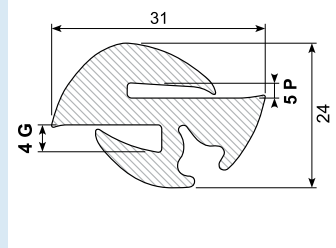

Material: EPDM black  
Hardness: SH 65  
Min. radius: 100 mm  
Safety

**32.866 \***

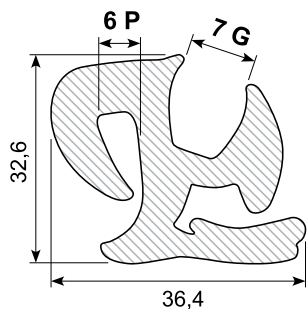

Material: EPDM black  
 Hardness: SH 65  
 Min. radius: 120 mm  
 Safety  
 Min. order: 250 m

**32.795S**

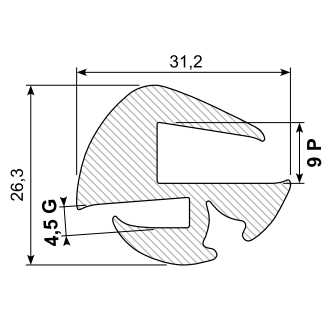

Material: EPDM black  
 Hardness: SH 65  
 Min. radius: 100 mm  
 Safety

**32.7125 \***

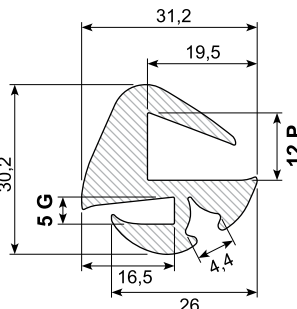

Material: EPDM black  
 Hardness: SH 65  
 Min. radius: 120 mm  
 Safety  
 Min. order: 250 m

**32.7195S**

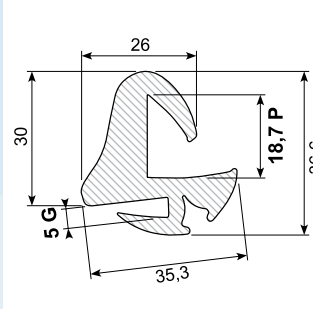

Material: EPDM black  
 Hardness: SH 65  
 Min. radius: 120 mm  
 Safety

**31.365**

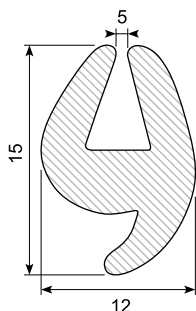

Material: EPDM black  
 Hardness: SH 65

**31.116S**

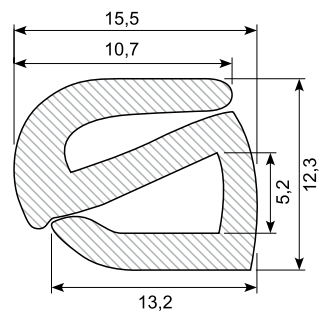

Material: EPDM black  
 Hardness: SH 65

**31.112S**

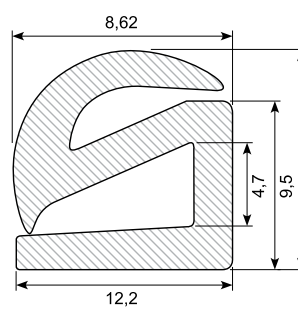

Material: EPDM black  
 Hardness: SH 65

**31.145S**

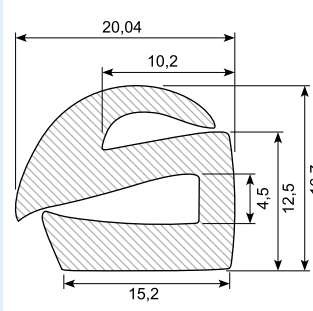

Material: EPDM black  
 Hardness: SH 65

**31.148**

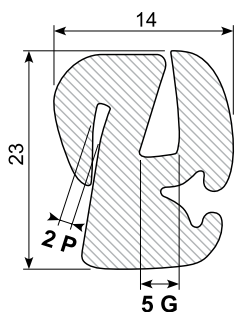

Material: EPDM black  
 Hardness: SH 65

**31.155**

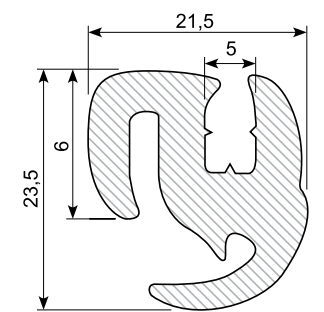

Material: EPDM black  
 Hardness: SH 65

**31.6701**

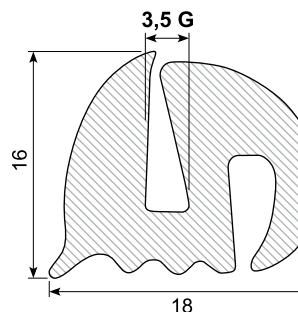

Material: EPDM black  
 Hardness: SH 65

**31.6703 \***

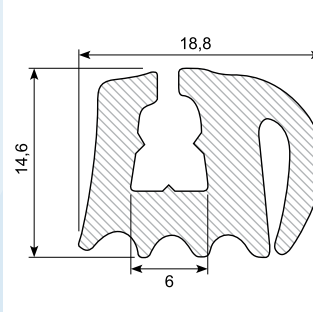

Material: EPDM black  
 Hardness: SH 65  
 Min. order: 1.000 m

**31.6702 \***

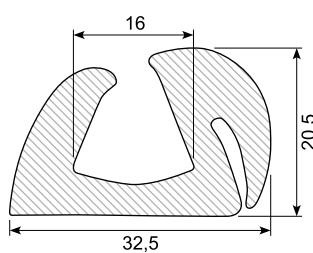

Material: EPDM black  
 Hardness: SH 65  
 Min. order: 500 m