

Spænder Clamps

Horizontal spænder. Force-pressure-hold.

Horizontal clamps. Force-pressure-hold.

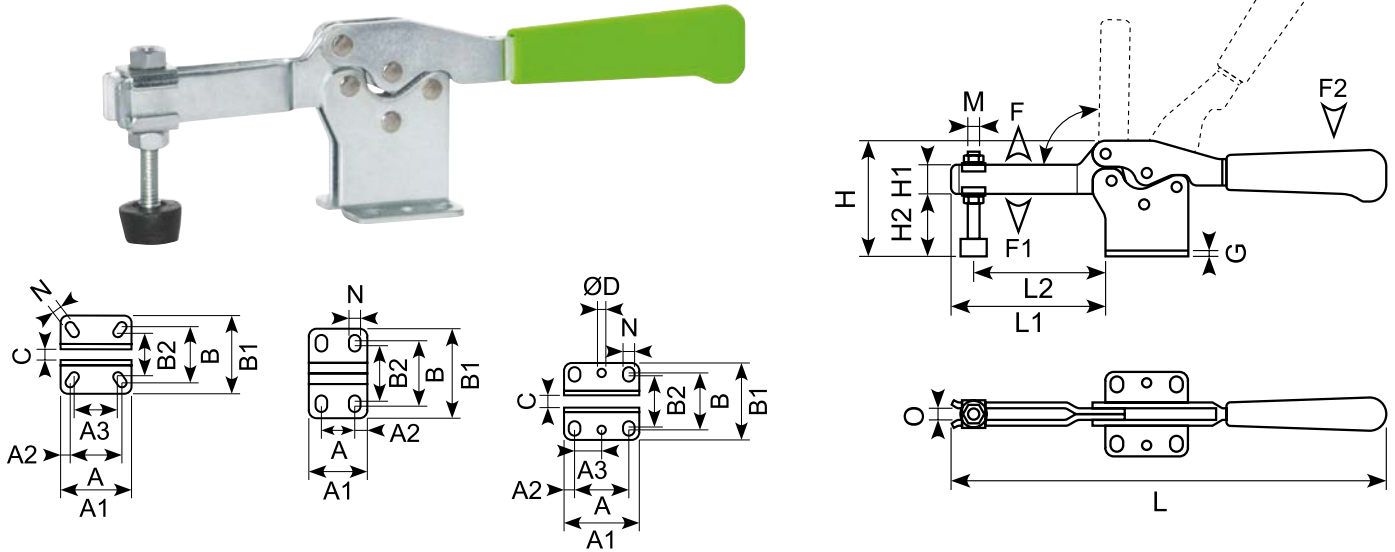

Varenr. Item no.	Vægt Weight	F daN	F1 daN	F2 daN	A	A1	A2	A3	B	B1	B2	C	ØD	G	H	H1	H2	L	L1	L2	M	N	O	α
58.901	0,09	90	25	6	13,3	25	5,7	-	21,5	32	15,6	-	-	2	36	10	21	121	41	15-30	M5x30	4,9	5	90°
58.902	0,19	130	35	9	26	37	5,2	13,7	28,2	39	20,6	5	4,8	2,5	46	13	26	163	61	22-50	M6x35	5,5	6	90°
58.012	0,27	150	55	9	26	42	7,9	-	38	50	20,3	-	-	3	51	14	29	186	57	17-44	M6x40	6,1	6	90°
58.903	0,4	210	60	12	25,7	40	7,6	12,9	30,3	44	25,8	6	4,8	3	65	17	37	234	81	28-67	M8x55	7,5	8	90°
58.904	0,84	320	75	15	40,8	57	7,8	20,5	43,2	58	39,1	8	5,7	4	80	20	42	301	106	33-91	M8x65	8,6	8	90°
58.906	1,5	500	90	18	49	67	9	41,4	53	74	41,4	10	-	5	97	25	61	359	131	42-112	M10x112	8,8	10	90°

Spænder Clamps

Spænder, horisontal sidemontage. Force-pressure-hold.

Side horizontal clamp. Force-pressure-hold.

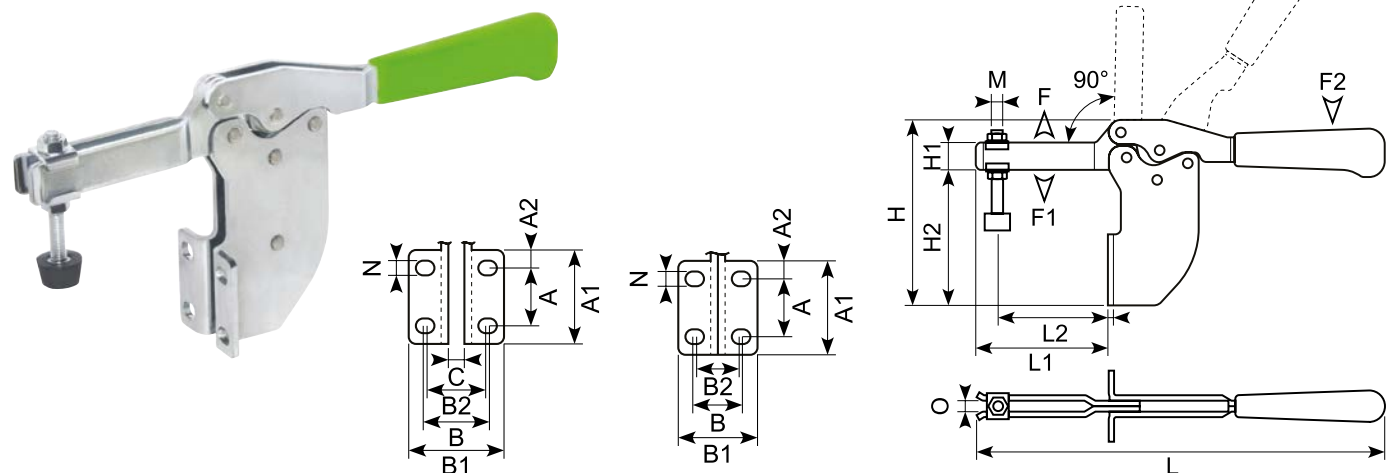

Varenr. Item no.	Vægt Weight	F daN	F1 daN	F2 daN	A	A1	A2	B	B1	B2	C	G	H	H1	H2	L	L1	L2	M	N	O	α
58.922	0,24	130	35	9	20	32	6	27,5	38	25,5	5	2,5	80	13	60	163	55	15-43	M6x35	5,5	6	90°
58.022	0,35	150	55	9	22,4	37	7,3	40,4	55	24,4	-	3	98	14	76	186	51	10-38	M6x40	7,7	6	90°
58.923	0,48	210	60	12	24	38	7	30,5	43	28,5	6	3	106	17	78	234	74	21-59	M8x55	6,5	8	90°
58.924	1	320	75	15	32	52	10	35,5	52	32	8	4	136	20	98	301	96	22-81	M8x65	8,5	8	90°

Spænder Clamps

Variabel horizontal spænder. Force-pressure-hold.

Variable horizontal clamp. Force-pressure-hold.

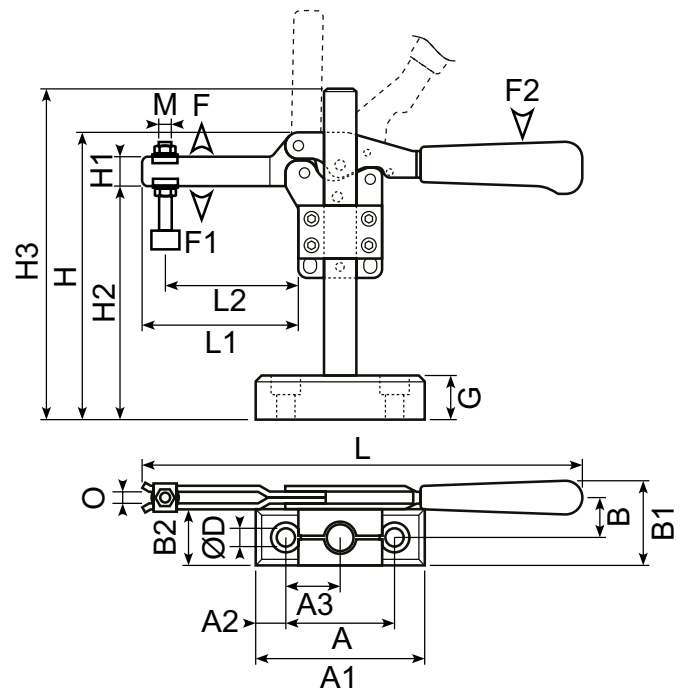

Varenr. Item no.	Vægt Weight	F daN	F1 daN	F2 daN	A	A1	A2	A3	B	B1	B2	G	H	H1	H2	H3	L	L1	L2	ØD	M	O	α
58.963*	1,4	210	60	12	60	90	15	30	23	49	34	26	90-248	17	64-222	206	234	81	28-66	8,5	M8x55	8	90°
58.964*	2,8	320	75	15	74	115	20,5	37	27	58	38	30	115-274	20	78-237	225	301	106	33-90	12,5	M8x65	8	90°
58.966*	4,08	500	90	18	90	140	25	45	29	62	38	36	139-277	25	128-266	216	359	131	41-111	16,5	M10x90	10	90°

58.077

Modsat horizontal spænde. Force-pressure-hold.

Reversed horizontal clamp. Force-pressure-hold.

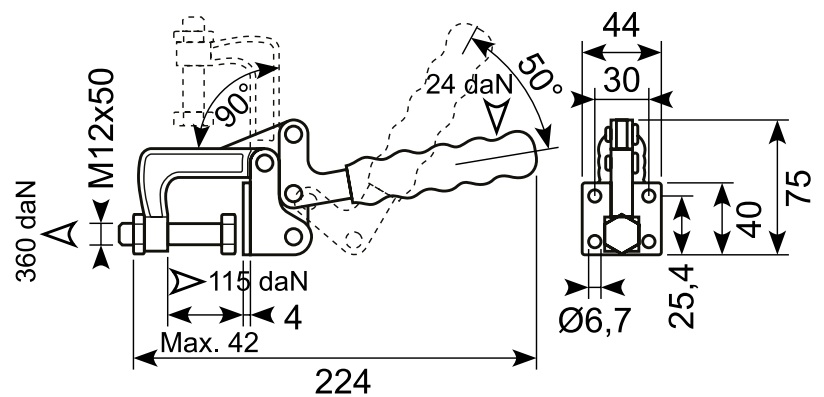
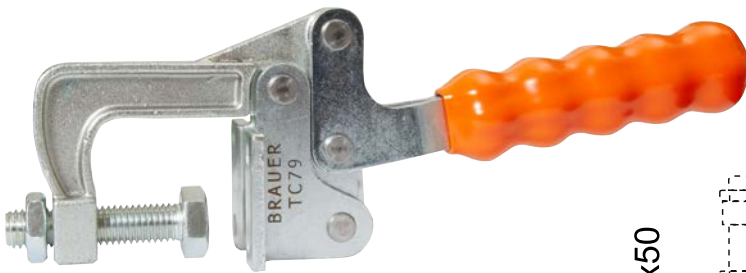

Vægt Weight	F daN	F1 daN	F2 daN
0,56	320	115	24

Spænder Clamps

Vertikal spænder. Force-pressure-hold.

Vertical clamp. Force-pressure-hold.

Model B

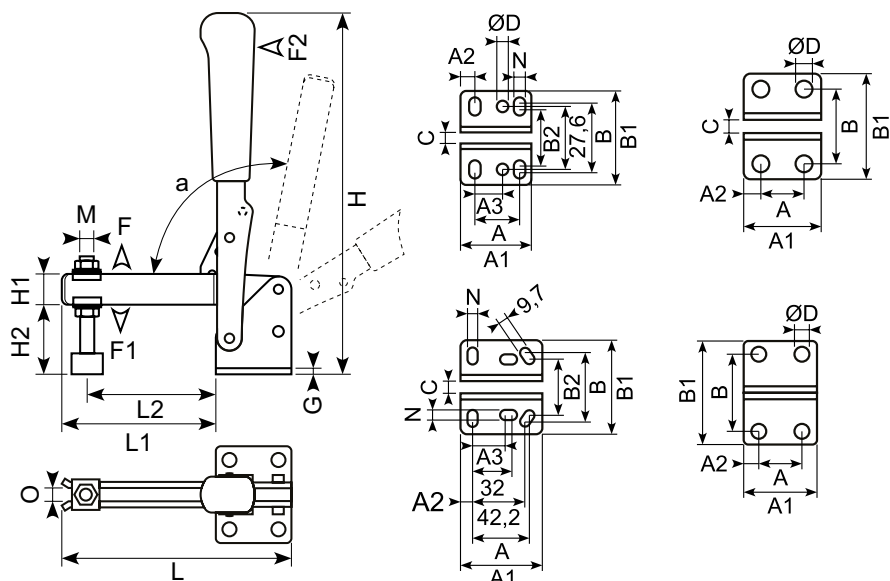
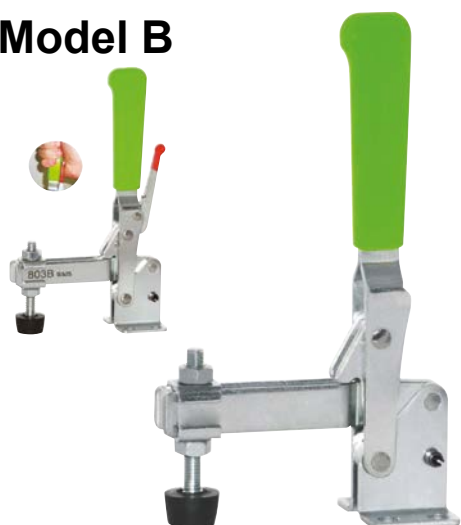

Varenr. Item no.	Vægt Weight	F daN	F1 daN	F2 daN	A	A1	A2	A3	B	B1	B2	C	ØD	G	H	H1	H2	L	L1	L2	M	N	O	α
58.801	0,11	90	40	6	16	26	5,3	-	24,6	35	-	4	4,9	2	107	10	20	62	36	12-26	M5x30	-	5	100°
58.802	0,2	130	70	9	20,2	32	6,6	12,6	32,4	43	26	5	5,2	2,5	132	13	24	80	47	13-35	M6x35	5	6	100°
58.112	0,37	150	65	9	20	34	7	-	33,9	48	-	-	7	3	176	14	28	96	62	19-49	M6x40	-	6	102°
58.803	0,40	210	90	12	19,5	35	7,8	-	34,2	48	-	6	7,9	3	189	17	35	111	76	19-61	M8x55	-	8	90°
58.804	0,84	320	130	15	32	49,5	9	-	45,1	63	-	8	8,9	4	239	20	46	151	102	19-87	M8x65	-	8	90°
58.804B	0,90	320	130	15	32	49,5	9	-	45,1	63	-	8	8,9	4	239	20	46	151	102	19-87	M8x65	-	8	90°
58.806	1,58	500	150	18	45,7	66	9,8	26	56	76	45	10	-	5	278	25	55	203	137	24-117	M10x90	8,3	10	90°

Spænder Clamps

Spænder, vertikal sidemontage. Force-pressure-hold.

Side vertical clamp. Force-pressure-hold.

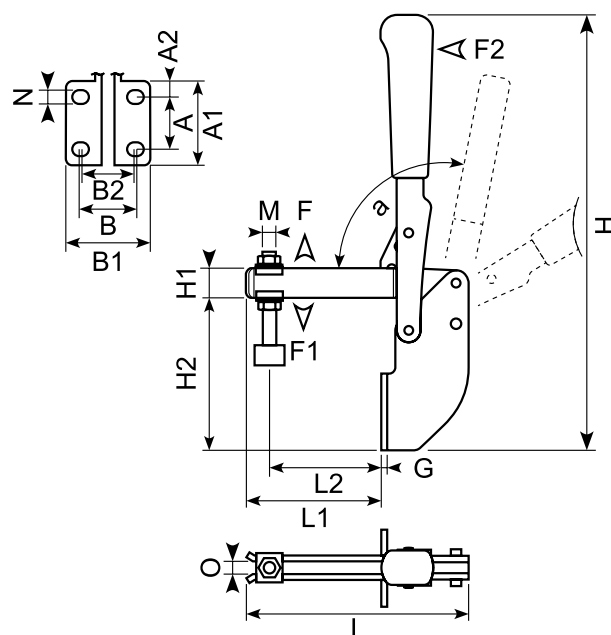

Varenr. Item no.	Vægt Weight	F daN	F1 daN	F2 daN	A	A1	A2	B	B1	B2	G	H	H1	H2	L	L1	L2	M	N	O	α
58.822	0,25	130	70	9	20	32	6	27,5	38	25,5	2,5	166	13	59	80	40	7-29	M8x35	5,5	6	91°
58.823	0,47	210	90	12	24	38	7	30,5	43	28,5	3	230	17	76	111	68	11-54	M8x55	6,5	8	91°
58.824	0,9	320	130	15	32	52	10	35,5	52	32	4	295	20	102	151	92	9-77	M8x65	8,5	8	91°

Spænder Clamps

Forstærket vertikal spænder. Force-pressure-hold.
Strengthened vertical clamp. Force-pressure-hold.

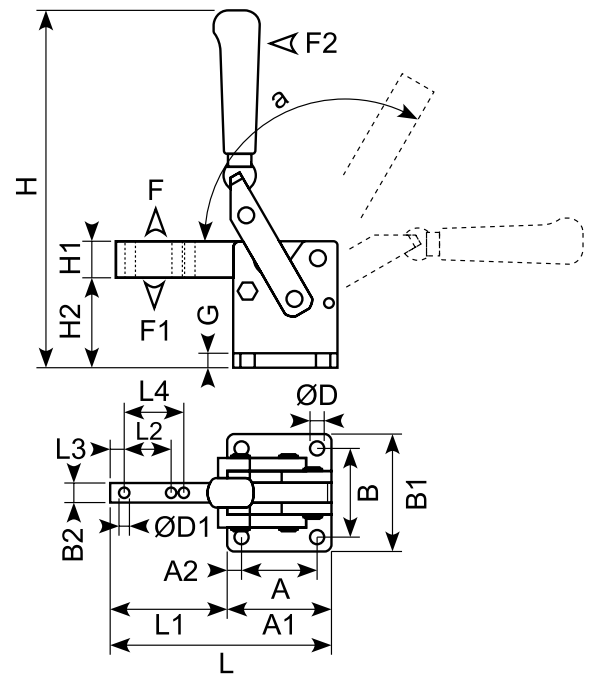

Varenr. Item no.	Vægt Weight	F daN	F1 daN	F2 daN	A	A1	A2	B	B1	B2	ØD	ØD1	G	H	H1	H2	L	L1	L2	L3	L4	α
58.211	0,46	300	70	9	28	40	6	34	46	10	6	5	6	143	14	35	85	45	10	6	-	120°
58.213	1,5	700	130	12	46	64	9	54	72	12	9	6	9	220	22	56	136	72	20	8	-	119°
58.215	2,92	1200	150	15	58	80	11	68	90	15	11	8	11	268	28	69	170	90	25	11	36	118°
58.217	5,8	2300	200	18	76	100	12	76	104	20	13	10	13	326	36	87	216	116	32	14	46	117°

Spænder Clamps

Vertikal spænder. Ekstra stærk med cover og lige base. Force-pressure-hold.
Strong vertical clamps with cover and straight basis. Force-pressure-hold.

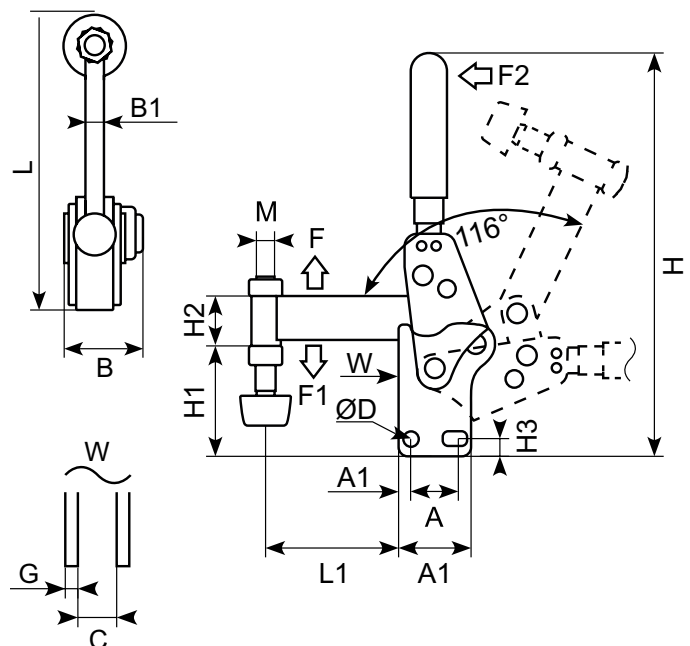

Varenr. Item no.	Vægt Weight	F daN	F1 daN	F2 daN	A	A1	A2	B	B1	C	ØD	G	H	H1	H2	H3	L	L1	M	α	R
58.282C *	0,42	250	70	9	20	33	6,5	29,5	7,8	8,2	6,1	3	150	48,5	20	9	86,5	35	M8x50	116°	3
58.284C *	1,22	500	130	12	30	44,5	7,5	39,5	9,8	10,2	8,5	4	234	71,5	28	11	154	82,5	M10x75	116°	5
58.286C *	2,49	1.000	150	15	45	65	10	52	11,8	12,2	10,5	6	278	87,5	36	14,6	188	100	M12x100	116°	7

* Skaffevare / Special order item

Spænder Clamps

Push-pull spænder. Force-pressure-hold.

Push-pull toggle clamps. Force-pressure-hold.

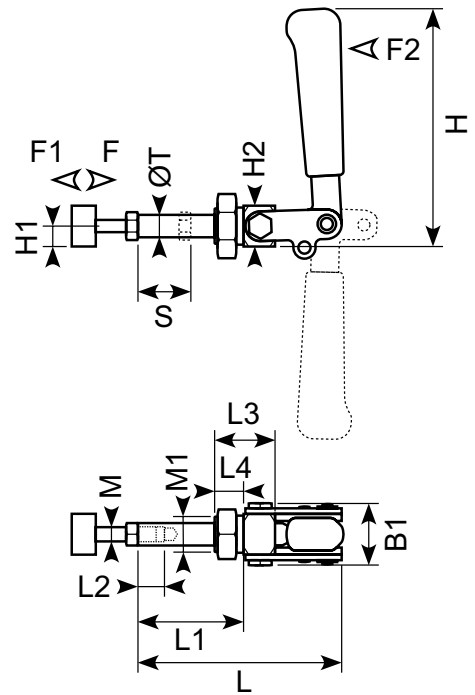

Varenr. Item no.	Vægt Weight	F daN	F1 daN	F2 daN	H	H1	H2	L	L1	L2	L3	L4	M	S	ØT
58.031	0,19	100	100	9	94	10	20	70	14-35	20	24,5	13	M6x30	21	10
58.033	0,4	250	250	12	128	11	22	111	17-57	25	33	16	M8x35	40	12
58.035 *	0,9	400	400	18	159	15	30	176	25-92	30	52	24	M10x50	67	16

Spænder Clamps

Push-pull spænder med beslag. Force-pressure-hold.

Push-pull clamps with bracket. Force-pressure-hold.

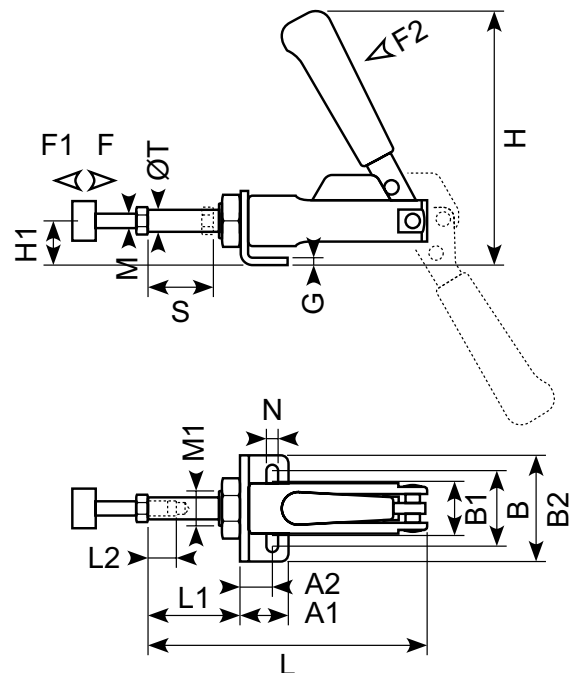

Varenr. Item no.	Vægt Weight	F daN	F1 daN	F2 daN	A1	A2	B	B1	B2	G	H	H1	L	L1	L2	M	M1	N	S	ØT
58.032	0,35	160	170	6	22	15	36	24	50	4	116	20	111	11-34	20	M6x30	M16x1,5	6,5	23	10
58.034	0,70	250	240	12	26	17	42	28	59	5	143	26	162	17-51	25	M8x35	M20x1,5	8,2	34	12
58.036	1,38	450	300	18	34	22	48	35	69	6	174	30	205	19-61	30	M10x50	M24x1,5	11	42	16

* Skaffevare / Special order item

Spænder Clamps

Push-pull spænder med lavt beslag. Force-pressure-hold.

Low push-pull clamp. Force-pressure-hold.

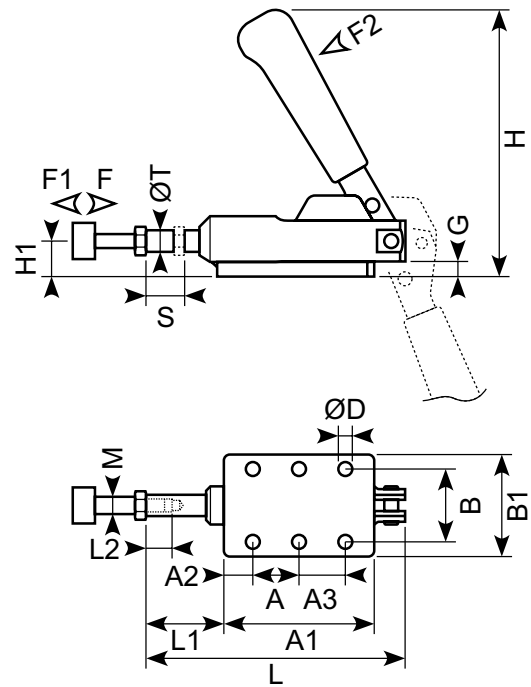

Varenr. Item no.	Vægt Weight	F daN	F1 daN	F2 daN	A	A1	A2	A3	B	B1	ØD	G	H	H1	L	L1	L2	M	S	ØT
58.042	0,42	160	170	6	25	52	9,5	-	39	50	6,5	6	112	16	111	10-33	20	M6x30	23	10
58.044	0,84	240	240	12	35	85	12,5	-	46	60	8,5	8	137	20	162	15-49	25	M8x35	34	12
58.046*	1,66	300	300	18	35	100	15	35	53	70	11	10	167	23	205	19-61	30	M10x50	42	16

Spænder Clamps

Horizontal spænder med bøjle. Force-pressure-hold.

Horizontal clamp with catch. Force-pressure-hold.

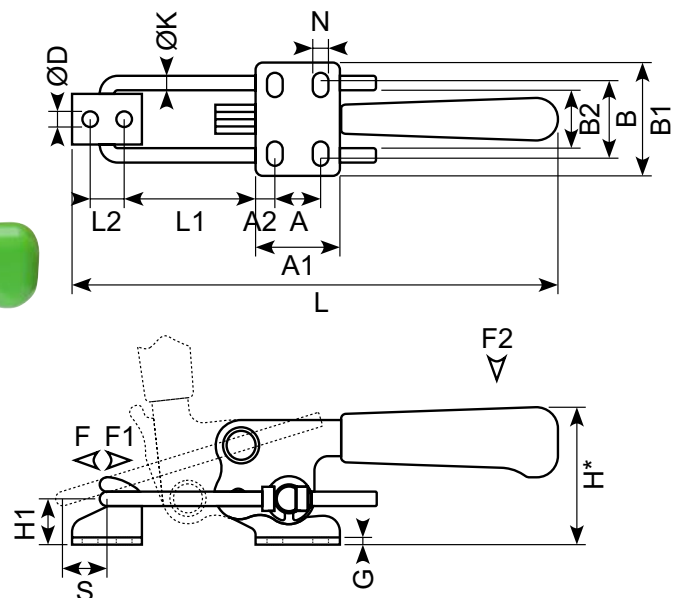

Varenr. Item no.	Vægt Weight	F daN	F1 daN	F2 daN	A	A1	A2	B	B1	B2	ØD=N	G	H*	H1	ØK	L	L1	L2	S
58.721	0,16	200	180	10	13	26	6,5	24	36	19	5,2	2,5	42	12	4	135-170	28-63	11	20
58.723	0,36	400	270	15	19	35	8	30	47	25	6,5	3	57	19	6	185-230	35-80	14	26
58.725	0,82	700	450	20	32	51	9,5	40	64	36	8,5	4	75	25	8	235-300	46-111	19	34

* Skaffevare / Special order item

Spænder Clamps

Horizontal spænder med bøjle og sikkerhedslås. Force-pressure-hold.
Horizontal clamp with catcher and safety device. Force-pressure-hold.

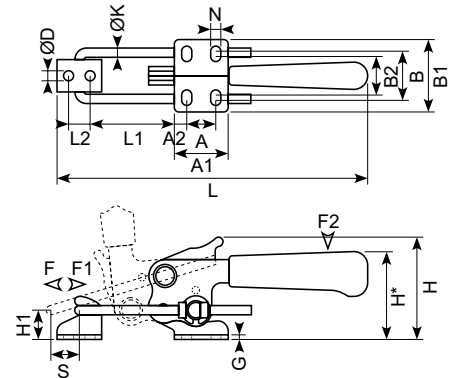

Varenr. Item no.	Vægt Weight	F daN	F1 daN	F2 daN	A	A1	A2	B	B1	B2	ØD=N	G	H	H*	H1	ØK	L	L1	L2	S
58.721B	0,18	200	180	10	13	26	6,5	25	36	19	5,2	2,5	51	42	12	4	135-170	28-63	11	20
58.723B	0,38	400	270	15	19	35	8	30	47	25	6,5	3	66	57	19	6	185-230	35-80	14	26
58.725B	0,88	700	450	20	32	51	9,5	40	64	36	8,5	4	86	75	25	8	235-300	46-111	19	34

Spænder Clamps

Vertikal spænder med bøjle. Force-pressure-hold.
Vertical clamp with catcher. Force-pressure-hold.

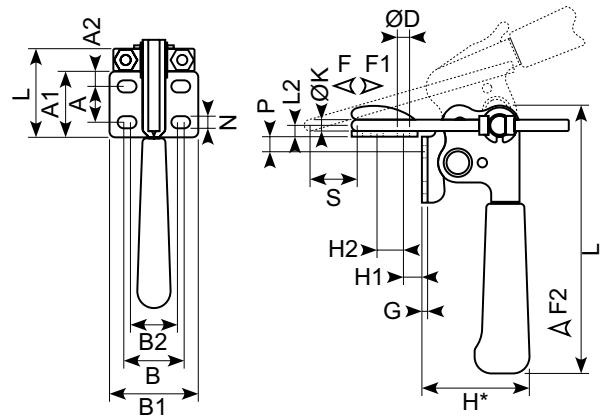

Varenr. Item no.	Vægt Weight	F daN	F1 daN	F2 daN	A	A1	A2	B	B1	B2	ØD=N	G	H*	H1	H2	ØK	L	L1	L2	P	S
58.731	0,16	200	180	10	13	26	6,5	24	36	19	5,2	2,5	42	5-28	11	4	103	40	4,5	7	20
58.733	0,36	400	270	15	19	35	8	30	47	25	6,5	3	57	7-35	14	6	142	52	6	8	26
58.735	0,82	700	450	20	32	51	9,5	40	64	36	8,5	4	75	9-45	19	8	179	74	8	9,5	34

Spænder Clamps

Horizontal spænder med sikkerhedslås. Force-pressure-hold.
Horizontal clamp with safety device. Force-pressure-hold.

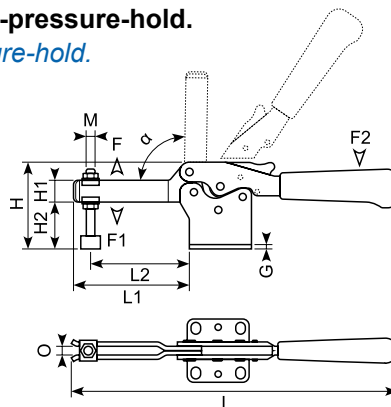

58.903B
58.904B

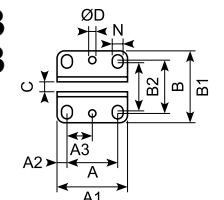

58.906B

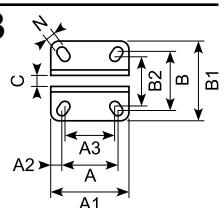

Varenr. Item no.	Vægt Weight	F daN	F1 daN	F2 daN	A	A1	A2	A3	B	B1	B2	C	ØD	G	H	H1	H2	L	L1	L2	M	N	O	α
58.903B	0,43	210	60	12	25,7	40	7,6	12,9	30,3	44	25,8	6	4,8	3	65	17	37	234	81	28 - 67	M8 x 55	7,5	8	90°
58.904B *	0,88	320	75	15	40,8	57	7,8	20,5	43,2	58	39,1	8	5,7	4	80	20	42	301	106	33 - 91	M8 x 65	8,6	8	90°
58.906B	1,56	500	90	18	49	67	9	41,4	53	74	41,4	10	-	5	97	25	61	359	131	42 - 112	M10 x 90	8,8	10	90°

* Skaffevare / Special order item

58.903SS

Rustfri horisontal spænder. Force-pressure-hold.
Stainless steel horizontal clamp. Force-pressure-hold.

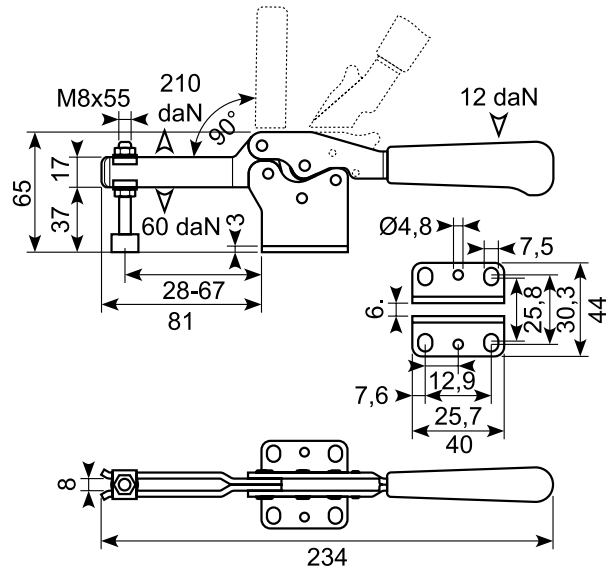

58.923SS

Rustfri spænder, horisontal sidemontage. Force-pressure-hold.
Stainless steel, side horizontal clamp. Force-pressure-hold.

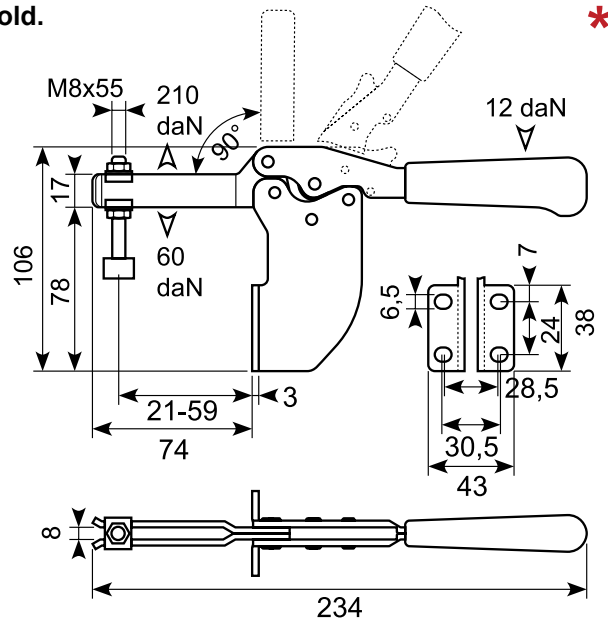

58.803SS

Rustfri vertikal spænder. Force-pressure-hold.
Stainless steel vertical clamp. Force-pressure-hold.

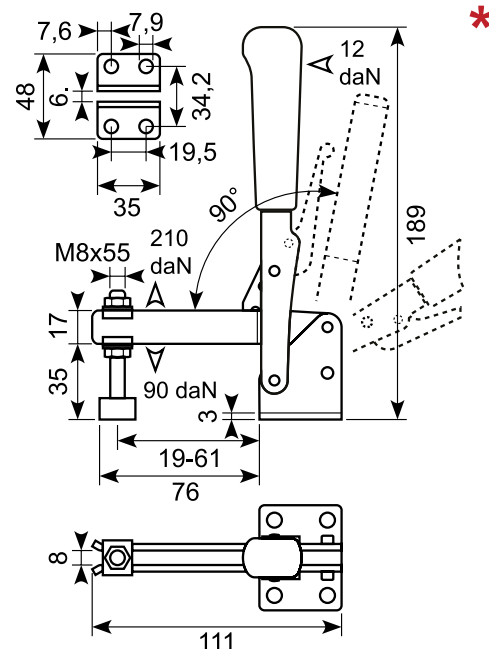

58.823SS

Rustfri spænder, vertikal sidemontage. Force-pressure-hold.

Stainless steel side vertical clamp. Force-pressure-hold.

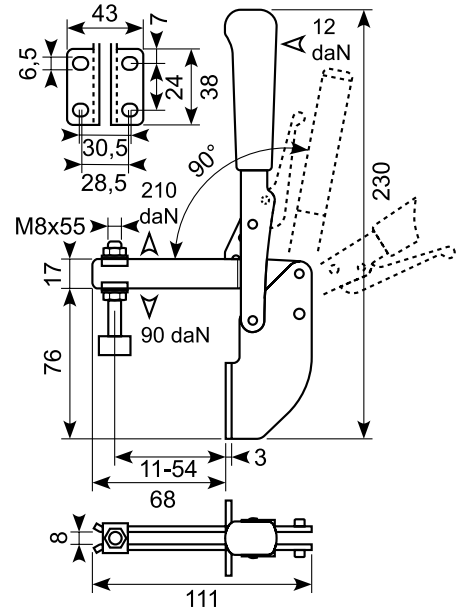

58.723SS

Rustfri horisontal spænder med 6 mm bøjle. Force-pressure-hold.

Stainless steel horizontal clamp with 6 mm catcher. Force-pressure-hold.

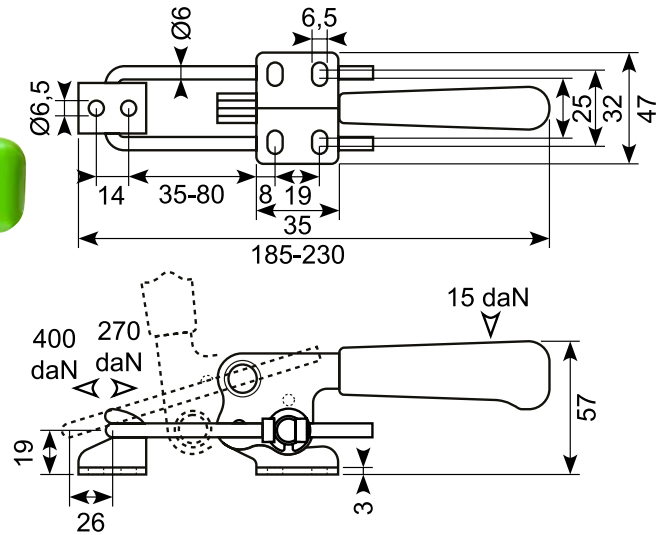

58.733SS

Rustfri vertikal spænder med 6 mm bøjle. Force-pressure-hold.

Stainless steel vertical clamp with 6 mm catcher. Force-pressure-hold.

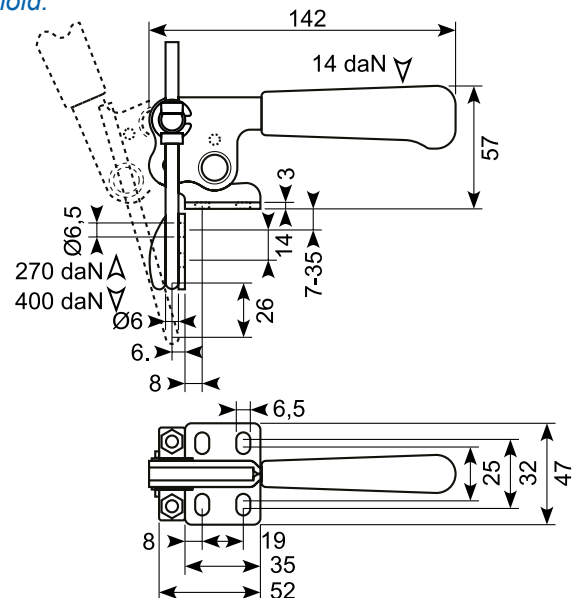

Rustfri push-pull spænder. Force-pressure-hold.
Stainless steel push-pull clamp. Force-pressure-hold.

Rustfri base til push-pull
Stainless base for push-pull

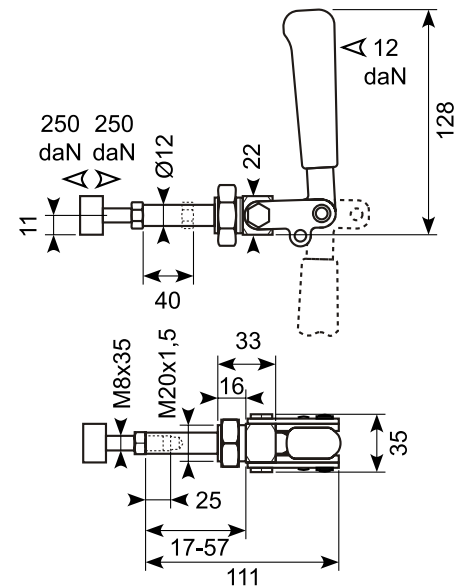
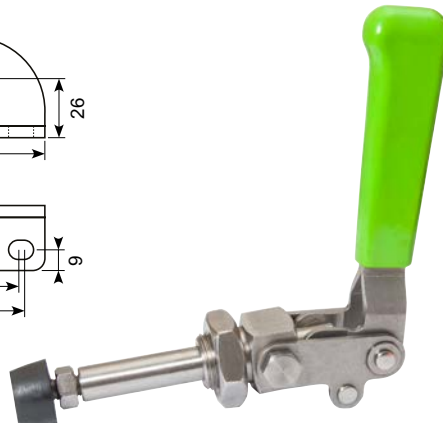
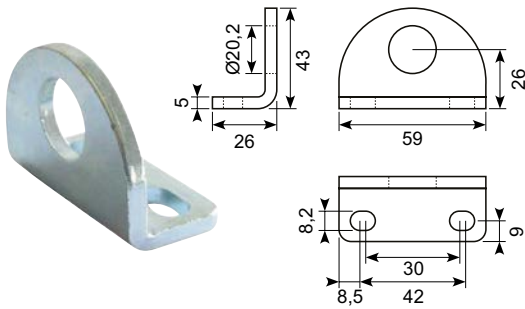

Base til push-pull Base for push-pull

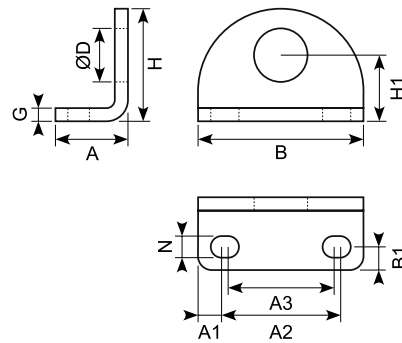

Varenr. Item no.	Vægt Weight	A	A1	A2	A3	B	B1	ØD	G	H	H1	N
58.132NG	0,06 kg	22	7	36	32	50	7	16,2	4	34	10	6,5
58.134NG	0,1 kg	26	8,5	42	30	59	9	20,2	5	43	26	8,2
58.134NGSS		26	8,5	42	30	59	9	20,2	5	43	26	8,2
58.136NG	0,18	34	10,5	48	30	69	12	24,2	6	51	30	11

Dobbeltarm Bi-thrust beam

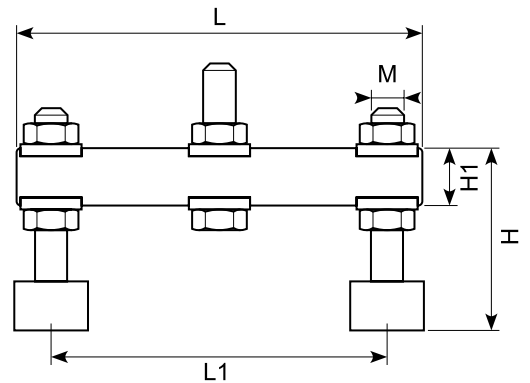
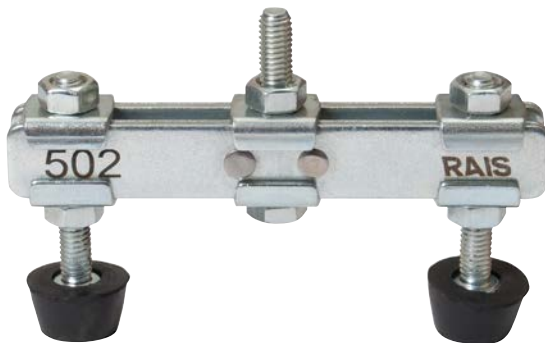

Varenr. Item no.	Vægt Weight	H	H1	L	L1	M	Mark for
58.502	0,14	30-44	14	96	32-80	M6x40	8..2.. , 9..2.. , 012, 022, 052, 112, 152
58.503	0,24	39-53	17	120	36-102	M8x50	8..3.. , 9..3..
58.504	0,35	40-71	20	150	48-132	M8x65	8..4.. , 9..4..
58.506	0,73	51-81	25	200	50-160	M10x90	8..6.. , 9..6..

Trykfod **Set screw**

Trykfodspændebolt med fjeder.

Set screw with plate springs.

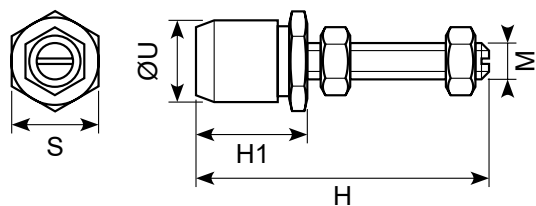

Varenr. Item no.	H	H1	M	S	ØU
58.512	54-56	16-18	M6	17	16
58.514	68-71	22-25	M8	19	19
58.516	94-98	27-31	M10	24	24

Trykfod **Set screw**

Trykfodspændebolt med vippefod.

Self-aligning set screw.

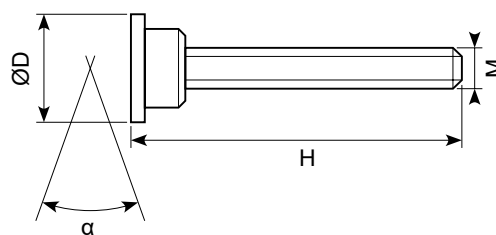

Varenr. Item no.	ØD	H	M	α	Mark for
58.612	19	68	M6	15°	213, 253
58.614	24	80	M8	15°	215, 255, 422, 442
58.616	30	101	M10	15°	217, 257, 424, 444

Trykfod **Set screw**

Trykfodspændebolt med vulkaniseret gummifod.

Set screw with vulcanized beam flange.

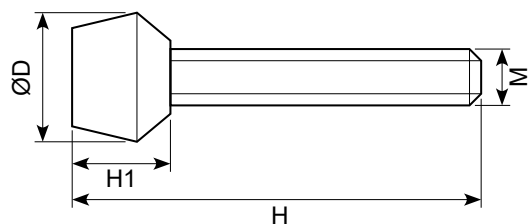

Varenr. Item no.	ØD	H	H1	M
58.621	13	38	10	M5x30
58.622 *	16	45	13	M6x35
58.623	21	63	16	M8x50
58.624	21	78	16	M8x65
58.626	26	116	20	M10x100

Trykfod **Set screw**

Trykfodspændebolt med lys gummifod.

Set screw with a light beam.

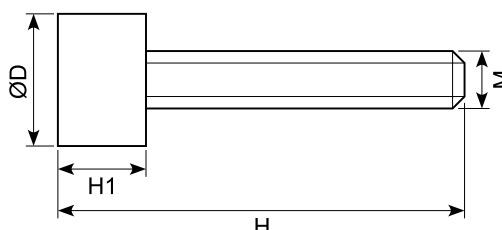

Varenr. Item no.	ØD	H	H1	M
58.632	15	46	13	M6x35
58.634	20	83	17	M8x70
58.636	25	93	18	M10x90

Fod **Foot**

Løs gummifod.

Rubber foot.

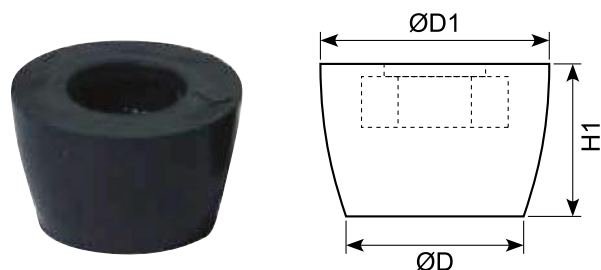

Varenr. Item no.	ØD	ØD1	H1	M
58.641	12	16	10	M5
58.642	14	18	11	M6
58.644	18	22	13	M8
58.646	20	26	16	M10

BIBUS[®]
SUPPORTING YOUR SUCCESS

BIBUS SK, s.r.o.
Trnavská 31, SK-94 901 Nitra

Tel.: 037/ 7777 911 Email: sale@bibus.sk
Fax.: 037/ 7777 999 http://www.bibus.sk