

Sponge rubber / Svampegummi

36.3704

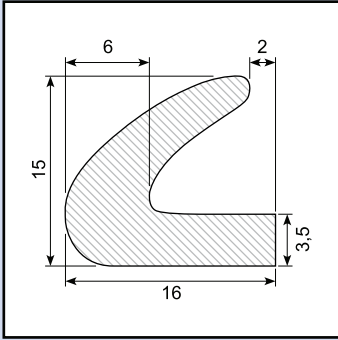

Material: NR dark grey
Hardness: SH 20 - 25
density 0,55 - 0,65

36.3704S

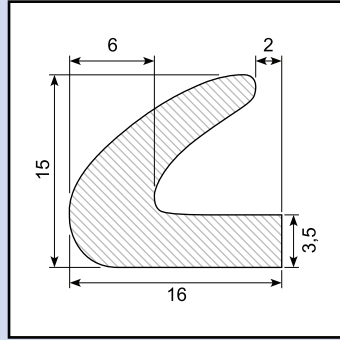

Material: Silicone red
Hardness: SH 18 - 20
density 0,4 - 0,5

36.3351

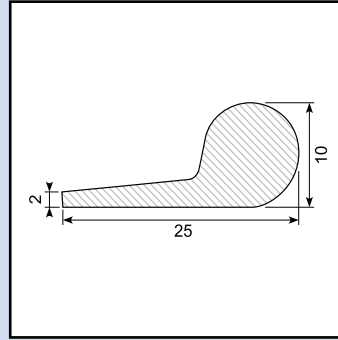

Material: EPDM black
Hardness: SH 14 - 16
density 0,38 - 0,4

36.3354 - 36.3354CR

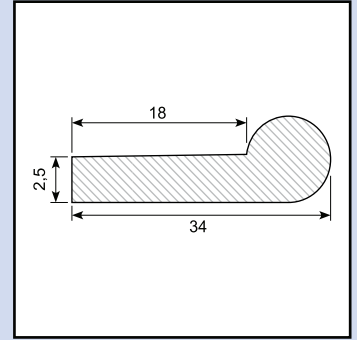

Material: NR dark grey
Hardness: SH 16 - 20
density 0,4
36.3354CR: CR dark grey

36.3352

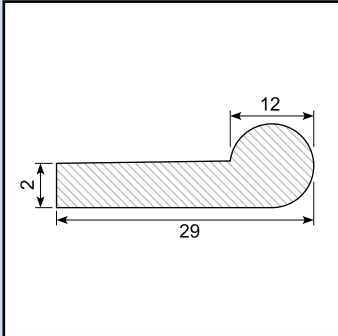

Material: NR dark grey
Hardness: SH 20 - 25
density 0,55 - 0,65

36.3813

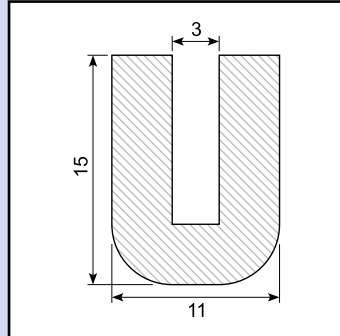

Material: EPDM dark grey
Hardness: SH 16 - 20
density 0,4 - 0,45

36.3314

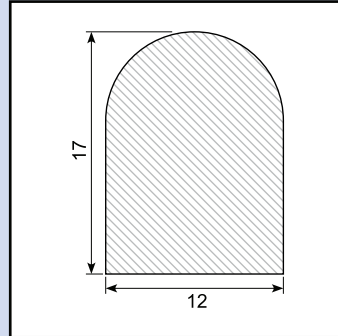

Material: NR dark grey
Hardness: SH 12 - 20
density 0,4

36.3315

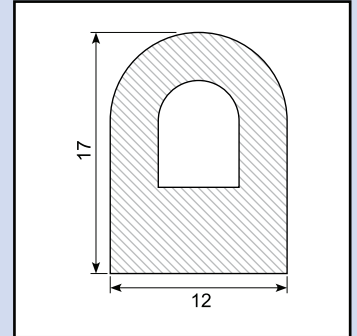

Material: CR black
Hardness: SH 18 - 20
density 0,45 - 0,55

36.3504

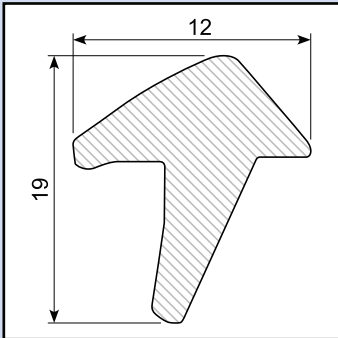

Material: EPDM dark grey
Hardness: SH 14 - 16
density 0,38 - 0,42

36.3881

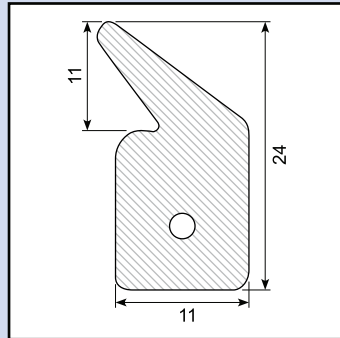

Material: EPDM grey
Hardness: SH 16 - 20
density 0,4 - 0,5

BIBUS[®]
SUPPORTING YOUR SUCCESS

BIBUS SK, s.r.o
Trnavská 31, SK-94 901 Nitra

Tel.: 037/ 7777 911 Email: sale@bibus.sk
Fax.: 037/ 7777 999 http://www.bibus.sk