

Elastomer Jaw Couplings

RINGFEDER® TNM G

Multi-part design, to change the intermediate ring without axial movement of the driven parts

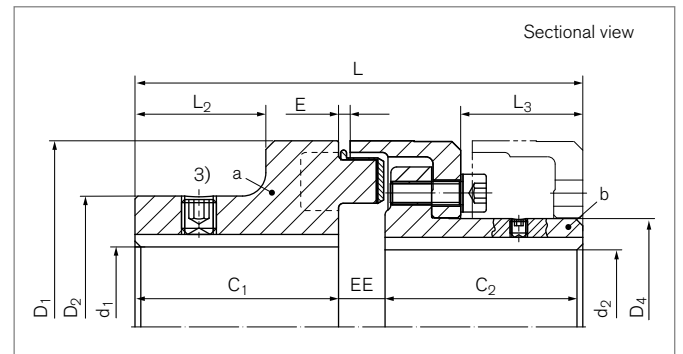
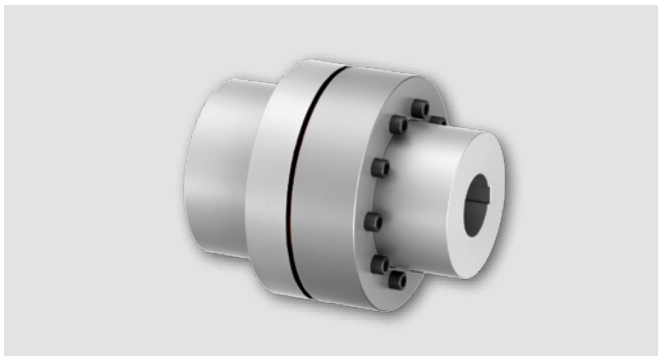

Identifier	Size	$T_{KNPb72}^{2)}$	$T_{KNPb82}^{2)}$	n_{max}	d_{1kmax}	d_{2kmax}	D_1	D_2	D_4	C_1
		Nm	Nm	1/min	mm	mm	mm	mm	mm	mm
WN0208	82	48	75	5000	32	32	82	53	44,5	40
WN0209	97	96	150	5000	42	39	97	69	54,5	50
WN0211	112	150	230	5000	48	46	112	79	64,5	60
WN0212	128	250	380	5000	55	53	128	90	74,5	70
WN0214	148	390	600	4500	65	65	148	107	92,5	80
WN0216	168	630	980	4000	75	75	168	124	104,5	90
WN0219	194	1050	1650	3500	85	85	194	140	121,5	100
WN0221	214	1500	2400	3000	95	95	214	157	135,5	110
WN0224	240	2400	3700	2750	110	100	240	179	146	120
WN0226	265	3700	5800	2500	120	115	265	198	164	140
WN0229	295	4900	7550	2250	130	130	295	214	181	150
WN0233	330	6400	9900	2000	150	135	330	248	208	160
WN0237	370	8900	14000	1750	170	160	370	278	241	180
WN0241	415	13200	20500	1500	190	180	415	315	275	200
WN0248	480	18000	28000	1400	210	200	480	315	289	220
WN0257	575	27000	41000	1200	230	260	575	350	368	240

To continue see next page

Elastomer Jaw Couplings RINGFEDER [®] TNM G

Identifier	Size	C ₂	L	L ₂	L ₃	E	F _E	EE	Gwa ¹⁾	GW _{ub}
		mm	mm	mm	mm	mm	mm	mm	kg	kg
WN0208	82	40	92	24	20	3	+/- 1,0	12	0,9	2,0
WN0209	97	49	113	30	30,5	3	+/- 1,0	14	1,7	3,4
WN0211	112	58	133	38	32,5	3,5	+/- 1,0	15	2,6	5,5
WN0212	128	68	154	45	42	3,5	+/- 1,0	16	4,1	8,3
WN0214	148	78	176	52	47	3,5	+/- 1,0	18	6,3	13,1
WN0216	168	87	198	56	52,5	3,5	+/- 1,5	21	9,6	19,4
WN0219	194	97	221	62	60	3,5	+/- 1,5	24	13,8	28,6
WN0221	214	107	243	68	66,5	4	+/- 2,0	26	19,1	38,8
WN0224	240	117	267	75	75,5	4	+/- 2,0	30	26,7	52,4
WN0226	265	137	310	90	88	5,5	+/- 2,5	33	37,5	75,3
WN0229	295	147	334	98	96	8	+/- 2,5	37	47,9	97,3
WN0233	330	156	356	104	101,5	8	+/- 2,5	40	66,5	130,0
WN0237	370	176	399	118	117	8	+/- 2,5	43	93,9	183,6
WN0241	415	196	441	135	131	8	+/- 2,5	45	129,7	258,2
WN0248	480	220	485	150	149	8	+/- 2,5	45	164,4	346,5
WN0257	575	240	525	170	168	8	+/- 2,5	45	233,5	528,8

¹⁾ Weight inclusive the half share of the intermediate ring

²⁾ Attention on peak load – see chapter „RINGFEDER [®] TNM Basic information“ in Product Paper & Tech Paper „RINGFEDER [®] Elastomer Jaw Couplings“

³⁾ Set screw on demand

Explanation

T _{KNPb72} = Coupling nominal torque by using the elastic element Pb72	D ₁ = Outer diameter	E = Gap width between left and right component
T _{KNPb82} = Coupling nominal torque by using the elastic element Pb82	D ₂ = Outer diameter hub	F _E = Tolerance of the gap width E
n _{max} = Max. rotation speed	D ₄ = Outer diameter hub	EE = Distance of the hubs
d _{1kmax} = Max. bore diameter d ₁ with keyway acc. to DIN 6885-1	C ₁ = Guided length in hub bore	Gwa = Weight of subassembly a
d _{2kmax} = Max. bore diameter d ₂ with keyway acc. to DIN 6885-1	C ₂ = Guided length in hub bore	GW _{ub} = Weight, unbored
	L = Total length	
	L ₂ = Length on the hub	
	L ₃ = Length	

Ordering example

Identifier	Size	d _{1k}	d _{2k}	Buffer identifier (optional) ⁴⁾	Further details
WN0224	240	90	70	Pb82	*

⁴⁾ Details on elastomer materials see chapter „Introduction“ and „RINGFEDER [®] TNM Basic information“ in Product Paper & Tech Paper „RINGFEDER [®] Elastomer Jaw Couplings“

⁵⁾ Without any other specification, we deliver as a standard: with set screws and keyway acc. to DIN 6885-1, keyway side fit P9, bore tolerance H7

Further information on RINGFEDER [®] TNM G on www.ringfeder.com

BIBUS
SUPPORTING YOUR SUCCESS

BIBUS SK, s.r.o
Trnavská 31, SK-94 901 Nitra

Tel.: 037/ 7777 911 Email: sale@bibus.sk
Fax.: 037/ 7777 999 <http://www.bibus.sk>

Disclaimer of liability

All technical details and notes are non-binding and cannot be used as a basis for legal claims. The user is obligated to determine whether the represented products meet his requirements. We reserve the right carry out modifications at any time in the interests of technical progress.

