

# Steel Disc Couplings

## RINGFEDER® TND XDX

Hubs with RINGFEDER® Shrink Discs, Double-Jointed, with Spacer, Shaft-Hub Connection by Shrink Disc

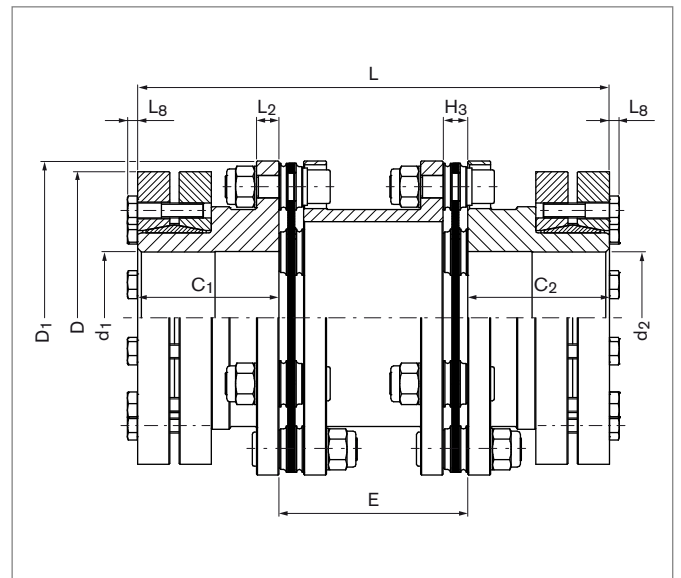

Size	T <sub>KNHD</sub> <sup>1)</sup>	T <sub>KNHT</sub> <sup>1)</sup>	n <sub>max</sub> <sup>2)</sup>	d <sub>1</sub> ; d <sub>2</sub> <sup>3)</sup> min	d <sub>1</sub> ; d <sub>2</sub> <sup>3)</sup> max	C <sub>1</sub> / C <sub>2</sub>	E <sup>5)</sup>	H <sub>3</sub>	D <sub>1</sub>	L <sub>2</sub>	L	n <sub>Sc</sub>	L <sub>8</sub>
XDX	Nm	Nm	1/min	mm	mm	mm	mm	mm	mm	mm	mm	Quantity	mm
82	750	1050	3600	38	60	55	100	10,5	116	10	210	6	4
							140				250		
							180				290		
98	1350	1750	3600	50	70	60	100	12	140,5	11	220	6	5,3
							140				260		
							180				300		
118	2400	3000	3600	50	75	75	100	13	166,5	12	250	6	5,3
							140				290		
							180				330		
141	4000	5200	3400	65	95	90	140	15	198,5	14	320	6	7,5
							180				360		
							250				500		
169	6500	8500	3000	65	105	125	140	21	238	16	390	6	10
							180				430		
							250				500		
205	21000	26000	2500	95	145	160	200	28	295	22	520	8	10
							250				570		
							300				624		
254	36000	44000	2100	94	160	200	224	32,5	345	26	624	8	10
							250				650		
							300				700		

To continue see next page

### Steel Disc Couplings RINGFEDER® TND XDX

Size	E <sup>5)</sup>	G <sub>wsp</sub>	C <sub>Tdyn</sub>		Max. Permissible Misalignment <sup>7)</sup>							
			HD	HT	axial		angular		radial			
XDX	mm	kg	10 <sup>6</sup> Nm/rad	10 <sup>6</sup> Nm/rad	ΔK <sub>a</sub> HD	ΔK <sub>a</sub> HT	ΔK <sub>w</sub> HD	ΔK <sub>w</sub> HT	ΔK <sub>r</sub> HD	ΔK <sub>r</sub> HT		
					mm	mm	Degrees	Degrees	mm	mm		
82	100	1,991	0,271	0,308	1,4	0,8	2	1,4	1,4	1,1		
	140	2,289	0,246	0,277							2,1	1,5
	180	2,586	0,226	0,251							2,8	2,1
	Δ per 100 mm	0,74	1,06									
98	100	3,188	0,513	0,543	2	1,2	2	1,4	2,1	1,5		
	140	3,627	0,469	0,494							2,8	2
	180	4,066	0,433	0,454								
	Δ per 100 mm	1,09	2,18									
118	100	4,874	0,914	0,948	2,4	1,6	2	1,4	2,1	1,5		
	140	5,574	0,855	0,884							2,8	2
	180	6,275	0,803	0,829								
	Δ per 100 mm	1,74	5,24									
141	140	7,944	1,306	1,362	2,8	1,6	2	1,4	2,7	2		
	180	8,718	1,229	1,279								
	Δ per 100 mm	1,92	8,3									
169	140	14,179	2,467	3,035	3	2,4	2	1,4	2,6	1,9		
	180	15,757	2,375	2,898							3,8	2,7
	250	18,520	2,231	2,686								
	Δ per 100 mm	3,92	25,36									
205	200	32,689	8,995	9,142	2,2	1,2	1	0,8	1,8	1,5		
	250	35,489	8,265	8,389								
	Δ per 100 mm	5,56	50,3									
254	224	54,420	14,975	15,19	2,2	1,6	1	0,8	1,8	1,3		
	250	56,404	14,302	14,497								
	300	60,22	13,163	13,328								
	Δ per 100 mm	7,58	81,63									

1) When selecting the coupling size, it is essential to observe the instructions on coupling dimensioning in the document "Product Paper & Tech Paper RINGFEDER® Steel Disc Couplings". Short-term peak torque T<sub>kmax</sub> is limited to 1.75 multiples of T<sub>KN</sub> or by the transmissible torque T of the shrink disc.  
 2) For longer spacers, check bending critical rotational speed.  
 3) Bore tolerance H6 up to diameter 80 mm; Bore tolerance H7 from diameter 80 mm.

5) Longer spacers on request. The figures given at "Δ per 100 mm" for G<sub>wsp</sub>, C<sub>Tdyn</sub>HD and C<sub>Tdyn</sub>HT are approximate values.  
 7) The maximum misalignment values must not apply simultaneously. The instructions on coupling dimensioning in the document "Product Paper & Tech Paper RINGFEDER® Steel Disc Couplings" are to be observed.

To continue see next page

## Steel Disc Couplings RINGFEDER® TND XDX

### Shaft-Hub Connection by Shrink Discs RINGFEDER® RfN 4061

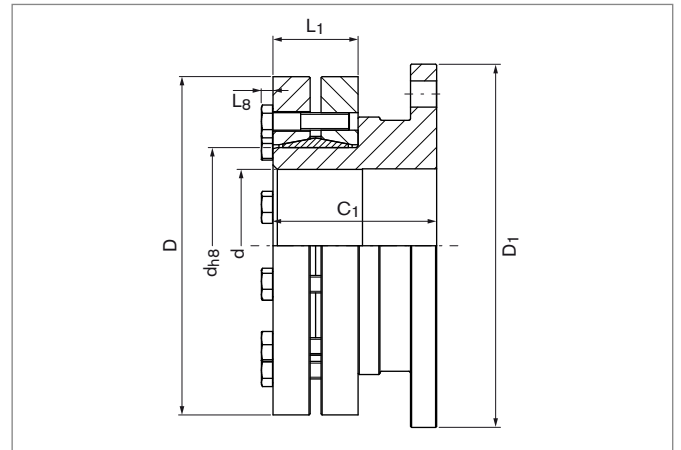

Shrink Discs RINGFEDER® RfN 4061					Sizing RINGFEDER® TND XDX								
dh8	x	D	L1	L8	d	T	Size	D1	C1 / C2	TKNHD <sup>1)</sup>	TKNHT <sup>1)</sup>	n <sub>max</sub>	Gw <sub>HS</sub>
mm		mm	mm	mm	mm	Nm	XDX	mm	mm	Nm	Nm	1/min	kg
50	x	90	27,5	4	38	1350	82	116	55	750	1050	3600	2,3
					40	1500							
					42	1700							
55	x	100	30,5	4	42	1300	82	116	55	750	1050	3600	2,4
					45	1550							
					48	1800							
68	x	115	30,5	4	48	1700	82	116	55	750	1050	3600	2,8
					55	2250							
					60	2850							
75	x	138	32,5	5,3	55	2650	98	140,5	60	1350	1750	3600	4,4
					60	3300							
					65	4050							
80	x	145	32,5	5,3	60	3200	98	140,5	60	1350	1750	3600	4,6
					70	4600							
					65	4800							
90	x	155	39	5,5	70	6050	141	198,5	90	4000	5200	3400	10,5
					75	7300							
					169	238							
115	x	185	56	6,4	75	9100	141	198,5	90	4000	5200	3400	12,6
					95	14050							
					169	238							
140	x	230	60,5	7,5	95	15100	169	238	125	6500	8500	3000	24,4
					100	17550							
					205	295							
165	x	290	71	10	105	20000	254	345	200	36000	44000	2100	60
					105	25000							
					125	39400							
185	x	330	86,4	10	125	43500	205	295	160	21000	26000	2500	60,4
					140	57350							
					254	345							
200	x	350	86	10	145	69000	254	345	200	36000	44000	2100	77,7
					155	81000							
					160	87200							

The transmissible torque of the coupling is dependent on the selected disc pack as well as the type of the shaft-hub connection. The lower torque limits the transmissibility and must be taken as a basis for the selection of the coupling.

To continue see next page

Steel Disc Couplings RINGFEDER <sup>®</sup> TND XDX

Explanations

$T_{KNHD}$ = Nom. transmissible torque with disc pack HD	$L_2$ = Hub flange thickness	$\Delta K_{wHT}$ = Max. permissible angular misalignment with disc pack HT
$T_{KNHT}$ = Nom. transmissible torque with disc pack HT	$L$ = Total length	$\Delta K_{rHD}$ = Max. permissible radial misalignment with disc pack HD
$n_{max}$ = Max. rotational speed	$n_{sc}$ = Quantity of screws	$\Delta K_{rHT}$ = Max. permissible radial misalignment with disc pack HT
$d_{1min}$ = Min. bore diameter $d_1$	$L_8$ = Overhang length	
$d_{2min}$ = Min. bore diameter $d_2$	$GW_{sp}$ = Weight of spacer	
$d_{1max}$ = Max. bore diameter $d_1$	$GW_{hs}$ = Weight of hub including shrink disc	
$d_{2max}$ = Max. bore diameter $d_2$	$C_{TdynHD}$ = Dynamic torsional stiffness with disc pack HD	<b>Shrink Disc Selection</b>
$C_1$ = Guided length in hub bore	$C_{TdynHT}$ = Dynamic torsional stiffness with disc pack HT	$d_{h8}$ = Inner diameter
$C_2$ = Guided length in hub bore	$\Delta K_{aHD}$ = Max. permissible axial misalignment with disc pack HD	$D$ = Outer diameter
$E$ = Distance between hubs	$\Delta K_{aHT}$ = Max. permissible axial misalignment with disc pack HT	$L_1$ = Min. installation length (without screws)
$H_3$ = Width of the disc pack	$\Delta K_{wHD}$ = Max. permissible angular misalignment with disc pack HD	$L_8$ = Overhang length
$D_1$ = Max. outer diameter		$d$ = Solid shaft diameter
		$T$ = Transmissible torque

Ordering example

Type	Size	Disc pack	Distance between hubs E	Bore diameter $d_1$	Shrink Disc RfN 4061 for bore diameter $d_1$	Bore diameter $d_2$	Shrink Disc RfN 4061 for bore diameter $d_2$
TND XDX	98	HD	100	50	68 x 115	60	68 x 115

Further information on RINGFEDER <sup>®</sup> TND XDX on [www.ringfeder.com](http://www.ringfeder.com)

Technical Information

- The specified values for transmissible torques are valid as follows: Shaft tolerance h6 for shaft diameters up to 50 mm; Shaft tolerance g6 for shaft diameters from 50 mm; Surface quality  $R_a \leq 3.2 \mu m$ .
- From a peripheral speed of 30 m/s, separate balancing of the individual coupling parts is recommended.
- Without further instructions on balancing, the coupling parts are balanced individually according to DIN 21940-11 in quality G 6,3 at 1,500 1/min. The hubs and the spacer are balanced without screwed-on disc packs.



**BIBUS**  
SUPPORTING YOUR SUCCESS

BIBUS SK, s.r.o  
Trnavská 31, SK-94 901 Nitra

Tel.: 037/ 7777 911    Email: sale@bibus.sk  
Fax.: 037/ 7777 999    http://www.bibus.sk

Disclaimer of liability

All technical details and notes are non-binding and cannot be used as a basis for legal claims. The user is obligated to determine whether the represented products meet his requirements. We reserve the right to carry out modifications at any time in the interests of technical progress.

