

Steel Disc Couplings RINGFEDER® TND OCO

Standard Hubs with Open Flange, Double-Jointed,
with Compact-Spacer, Shaft-Hub Connection by Keyway

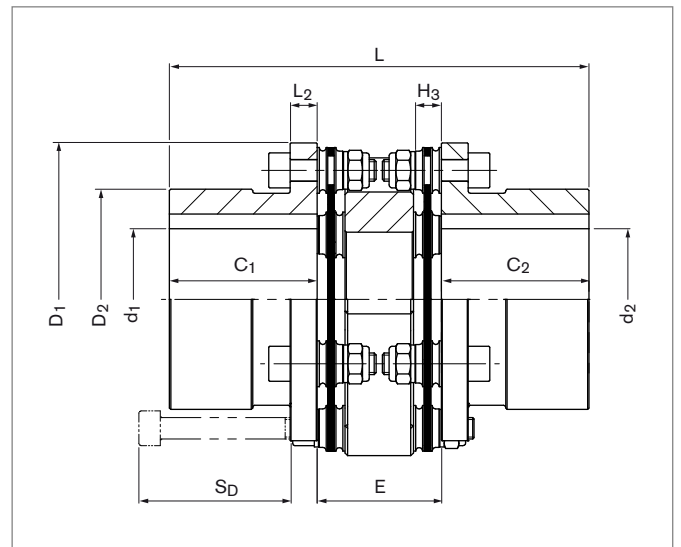

Size	T _{KNHD} ¹⁾	T _{KNHT} ¹⁾	n _{max}	d _{pre} ³⁾	d _{1k} ; d _{2k} max ⁴⁾	C ₁ / C ₂	E	H ₃	D ₁	D ₂	L ₂	L	S _D	n _{Sc}
OCO	Nm	Nm	1/min	mm	mm	mm	mm	mm	mm	mm	mm	mm	mm	Quantity
47	170	230	8400	10	32	39,5	31,2	7,5	70,5	47	5	110	24	6
63	320	420	6800	14	42	45	38	9	88	62,5	8	128	32	6
82	750	1050	5400	15	55	55	46,5	10,5	116	82	10	156,5	40	6
98	1350	1750	4600	19	65	60	55	12	140,5	98	11	175	47	6

Size	G _{WSB} ⁶⁾	J _{SB} ⁶⁾	C _{TdynHD}	C _{TdynHT}	Max. Permissible Misalignment ⁷⁾					
					axial		angular		radial	
OCO	kg	10 ⁻³ kgm ²	10 ⁶ Nm/rad	10 ⁶ Nm/rad	ΔK _{aHD}	ΔK _{aHT}	ΔK _{wHD}	ΔK _{wHT}	ΔK _{rHD}	ΔK _{rHT}
47	1,6	0,71	0,084	0,089	mm	mm	Degrees	Degrees	mm	mm
63	3,1	2,2	0,136	0,151	0,9	0,5	2	1,4	0,3	0,2
82	6,7	8	0,309	0,360	0,8	0,7	2	1,4	0,4	0,3
98	10,3	18	0,569	0,607	1,4	0,6	2	1,4	0,5	0,4
					2	1	2	1,4	0,7	0,5

1) When selecting the size, it is essential to observe the instructions on coupling dimensioning in the document "Product Paper & Tech Paper RINGFEDER® Steel Disc Couplings". Short-term peak torque T_{kmax} is limited to 1.75 multiples of T_{KN}.

3) Pre-bore has free tolerance.

4) Maximum finished bore with keyways according to DIN 6885-1.

6) Weight and mass moments of inertia for pre-bored hubs.

7) The maximum misalignment values must not apply simultaneously. The instructions on coupling dimensioning in the document "Product Paper & Tech Paper RINGFEDER® Steel Disc Couplings" are to be observed.

To continue see next page

Steel Disc Couplings RINGFEDER ® TND OCO

Explanations

T_{KNHD} = Nom. transmissible torque with disc pack HD	H_3 = Width of the disc pack	C_{TdynHT} = Dynamic torsional stiffness with disc pack HT
T_{KNHT} = Nom. transmissible torque with disc pack HT	D_1 = Max. outer diameter	ΔK_aHD = Max. permissible axial misalignment with disc pack HD
n_{max} = Max. rotational speed	D_2 = Outer diameter hub	ΔK_aHT = Max. permissible axial misalignment with disc pack HT
d_{pre} = Diameter pre-bore	L_2 = Hub flange thickness	ΔK_wHD = Max. permissible angular misalignment with disc pack HD
d_{1kmax} = Max. bore diameter d_1 with keyway acc. to DIN 6885-1	L = Total length	ΔK_wHT = Max. permissible angular misalignment with disc pack HT
d_{2kmax} = Max. bore diameter d_2 with keyway acc. to DIN 6885-1	S_D = Disassembly space	ΔK_rHD = Max. permissible radial misalignment with disc pack HD
C_1 = Guided length in hub bore	n_{sc} = Quantity of screws	ΔK_rHT = Max. permissible radial misalignment with disc pack HT
C_2 = Guided length in hub bore	$G_{W_{SB}}$ = Weight at smallest bore diameter	
E = Distance between hubs	J_{SB} = Moment of inertia at smallest bore diameter.	
	C_{TdynHD} = Dynamic torsional stiffness with disc pack HD	

Ordering example

Type	Size	Disc pack	Bore diameter d_1	Bore diameter d_2
TND OCO	98	HD	50	60

Further information on RINGFEDER ® TND OCO on www.ringfeder.com

Technical Information

- Without further specifications, we deliver as standard: Bore tolerance H7; Keyway acc. to DIN 6885-1; Keyway width tolerance P9; Set screw per hub.
- From a peripheral speed of 30 m/s, separate balancing of the individual coupling parts is recommended.
- Without further instructions on balancing, the coupling parts are balanced individually according to DIN 21940-11 in quality G 6,3 at 1,500 1/min. The hubs are balanced half key (before grooving), the spacer without screwed-on disc packs.

Disclaimer of liability

All technical details and notes are non-binding and cannot be used as a basis for legal claims. The user is obligated to determine whether the represented products meet his requirements. We reserve the right to carry out modifications at any time in the interests of technical progress.



BIBUS
SUPPORTING YOUR SUCCESS

BIBUS SK, s.r.o
Trnavská 31, SK-94 901 Nitra

Tel.: 037/ 7777 911 Email: sale@bibus.sk
Fax.: 037/ 7777 999 <http://www.bibus.sk>