

Steel Disc Couplings

RINGFEDER® TND HDV

Combination of Standard Hub and Inverted Hub, Double-Jointed, with Spacer, Shaft-Hub Connection by Keyway

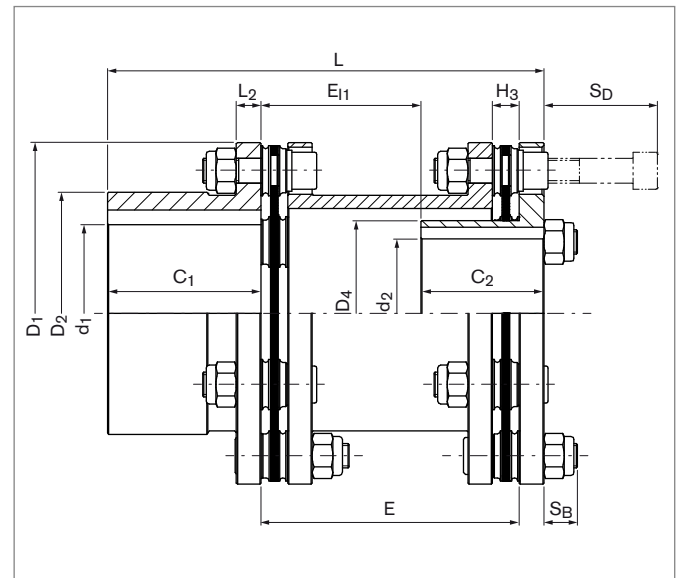
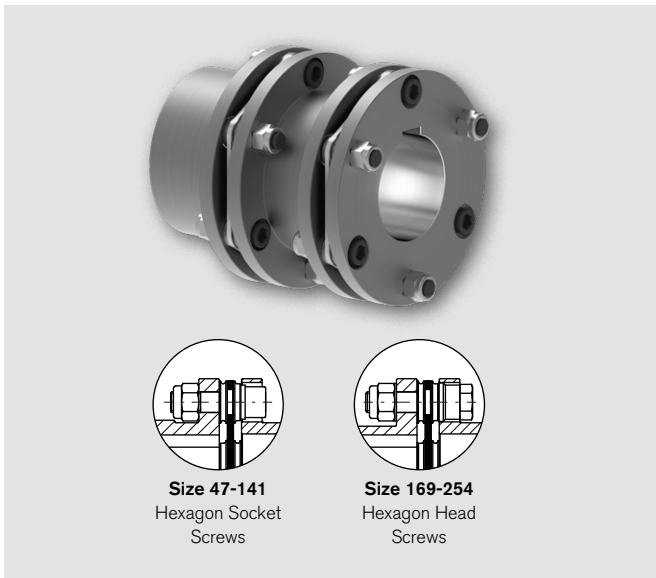

Size	T _{KNHD} ¹⁾	T _{KNHT} ¹⁾	n _{max} ²⁾	d _{pre} ³⁾	d _{1kmax} ⁴⁾	d _{2kmax} ⁴⁾	C ₁ /C ₂	E ₁	E ⁵⁾	H ₃	D ₁	D ₂	D ₄	L ₂	L	S _B	S _D	n _{Sc}
HDV	Nm	Nm	1/min	mm	mm	mm	mm	mm	mm	mm	mm	mm	mm	mm	mm	mm	mm	Quantity
47	170	230	8400	10	32	25	39,5	25,5	60	7,5	70,5	47	37	5	105	11	24	6
								65,5	100						185			
								105,5	140									
63	320	420	6800	14	42	32	45	33	70	9	88	62,5	48	8	123	14	32	6
								43	80						133			
								63	100						153			
								103	140						193			
82	750	1050	5400	15	55	44	55	55	100	10,5	116	82	64	10	165	16	40	6
								95	140						205			
								135	180						245			
98	1350	1750	4600	19	65	50	60	51	100	12	140,5	98	77	11	171	19	47	6
								91	140						211			
								131	180						251			
118	2400	3000	3800	25	85	60	75	37	100	13	166,5	118	90,5	12	187	21	55	6
								77	140						227			
								117	180						267			
141	4000	5200	3400	30	95	75	90	64	140	15	198,5	141	114	14	244	23	64	6
								104	180						284			
								31	140						281			
169	6500	8500	3000	39	115	90	125	71	180	21	238	169	135	16	321	29	81	6
								141	250						391			

To continue see next page

Steel Disc Couplings RINGFEDER® TND HDV

Size	T _{KN} HD ¹⁾	T _{KN} HT ¹⁾	n _{max} ²⁾	d _{pre} ³⁾	d _{1kmax} ⁴⁾	d _{2kmax} ⁴⁾	C ₁ /C ₂	E _{I1}	E ⁵⁾	H ₃	D ₁	D ₂	D ₄	L ₂	L	S _B	S _D	n _{Sc}
HDV	Nm	Nm	1/min	mm	mm	mm	mm	mm	mm	mm	mm	mm	mm	mm	mm	mm	mm	Quantity
205	21000	26000	2500	59	140	115	160	62 112	200 250	28	295	205	170	22	382 432	32	112	8
254	36000	44000	2100	79	175	120	200	50 76 126	224 250 300	32,5	345	254	180	26	450 476 526	40	133	8

Size	E ⁵⁾	G _{WSB} ⁶⁾	J _{SB} ⁶⁾	C _{Tdyn} HD	C _{Tdyn} HT	Max. Permissible Misalignment ⁷⁾					
						axial		angular		radial	
HDV	mm	kg	10 ⁻⁹ kgm ²	10 ⁶ Nm/rad	10 ⁶ Nm/rad	ΔK _a HD	ΔK _a HT	ΔK _w HD	ΔK _w HT	ΔK _r HD	ΔK _r HT
	mm	kg	10 ⁻⁹ kgm ²	10 ⁶ Nm/rad	10 ⁶ Nm/rad	mm	mm	Degrees	Degrees	mm	mm
47	60	1,4	0,69	0,071	0,075					0,8	0,6
	100	1,6	0,75	0,059	0,062	1,0	0,6	2	1,4	1,5	1,1
	140	1,7	0,8	0,051	0,053					2,2	1,5
63	70	2,9	2,33	0,123	0,134					1	0,7
	80	2,9	2,37	0,123	0,134					1,1	0,8
	100	3	2,46	0,116	0,127	1,0	0,8	2	1,4	1,5	1,1
	140	3,2	2,63	0,105	0,114					2,1	1,6
82	100	5,4	8,83	0,271	0,308					1,4	1,1
	140	6,7	9,23	0,246	0,277	1,4	0,8	2	1,4	2,1	1,5
	180	7	9,65	0,226	0,251					2,8	2,1
98	100	9,9	20,35	0,513	0,543					1,5	1
	140	10,4	21,21	0,469	0,494	2,0	1,2	2	1,4	2,1	1,5
	180	10,8	22,07	0,433	0,454					2,8	2
118	100	16	46,28	0,914	0,948					1,4	1
	140	16,7	48,34	0,855	0,884	2,4	1,6	2	1,4	2,1	1,5
	180	17,3	50,39	0,803	0,829					2,8	2
141	140	26,4	98,01	1,306	1,362	2,8	1,6	2	1,4	2	1,5
	180	28,5	105,33	1,229	1,279					2,7	2
169	140	50,7	289,79	2,467	3,035					2	1,4
	180	52,3	299,74	2,375	2,898	3	2,4	2	1,4	2,6	1,9
	250	55	317,15	2,231	2,686					3,8	2,7
205	200	105	951,03	8,995	9,142	2,2	1,2	1	0,8	1,4	1,2
	250	107,8	975,71	8,265	8,389					1,8	1,5
254	224	169,2	2131,73	14,975	15,19					1,6	1,3
	250	171,2	2152,56	14,302	14,497	2,2	1,6	1	0,8	1,8	1,5
	300	175	2192,61	13,163	13,328					2,2	1,8

1) When selecting the size, it is essential to observe the instructions on coupling dimensioning in the document "Product Paper & Tech Paper RINGFEDER® Steel Disc Couplings". Short-term peak torque T_{kmax} is limited to 1.75 multiples of T_{KN}.
 2) For longer spacers, check bending critical rotational speed.
 3) Pre-bore has free tolerance.
 4) Maximum finished bore with keyways according to DIN 6885-1.

5) Longer spacers on request.
 6) Weight and mass moments of inertia for pre-bored hubs.
 7) The maximum misalignment values must not apply simultaneously. The instructions on coupling dimensioning in the document "Product Paper & Tech Paper RINGFEDER® Steel Disc Couplings" are to be observed.

To continue see next page

Steel Disc Couplings RINGFEDER [®] TND HDV

Explanations

T_{KNHD} = Nom. transmissible torque with disc pack HD	H_3 = Width of the disc pack	C_{TdynHD} = Dynamic torsional stiffness with disc pack HD
T_{KNHT} = Nom. transmissible torque with disc pack HT	D_1 = Max. outer diameter	C_{TdynHT} = Dynamic torsional stiffness with disc pack HT
n_{max} = Max. rotational speed	D_2 = Outer diameter hub	ΔK_aHD = Max. permissible axial misalignment with disc pack HD
d_{pre} = Diameter pre-bore	D_4 = Outer diameter of the inverted hub	ΔK_aHT = Max. permissible axial misalignment with disc pack HT
d_{1kmax} = Max. bore diameter d_1 with keyway acc. to DIN 6885-1	L_2 = Hub flange thickness	ΔK_wHD = Max. permissible angular misalignment with disc pack HD
d_{2kmax} = Max. bore diameter d_2 with keyway acc. to DIN 6885-1	L = Total length	ΔK_wHT = Max. permissible angular misalignment with disc pack HT
C_1 = Guided length in hub bore	S_B = Protruding of the screw	ΔK_rHD = Max. permissible radial misalignment with disc pack HD
C_2 = Guided length in hub bore	S_D = Disassembly space	ΔK_rHT = Max. permissible radial misalignment with disc pack HT
E_{11} = Distance between hubs	n_{sc} = Quantity of screws	
E = Distance between hubs	Gw_{SB} = Weight at smallest bore diameter	
	J_{SB} = Moment of inertia at smallest bore diameter	

Ordering example

Type	Size	Disc pack	Distance between hubs E	Bore diameter d_1	Bore diameter d_2
TND HDV	118	HD	140	85	60

Further information on RINGFEDER [®] TND HDV on www.ringfeder.com

Technical Information

- Without further specifications, we deliver as standard: Bore tolerance H7; Keyway acc. to DIN 6885-1; Keyway width tolerance P9; Set screw per hub.
- From a peripheral speed of 30 m/s, separate balancing of the individual coupling parts is recommended.
- Without further instructions on balancing, the coupling parts are balanced individually according to DIN 21940-11 in quality G 6,3 at 1,500 1/min. The hubs are balanced half key (before grooving), the spacer without screwed-on disc packs.



BIBUS[®]
SUPPORTING YOUR SUCCESS

BIBUS SK, s.r.o
Trnavská 31, SK-94 901 Nitra

Tel.: 037/ 7777 911 Email: sale@bibus.sk
Fax.: 037/ 7777 999 <http://www.bibus.sk>

Disclaimer of liability

All technical details and notes are non-binding and cannot be used as a basis for legal claims. The user is obligated to determine whether the represented products meet his requirements. We reserve the right to carry out modifications at any time in the interests of technical progress.