

Steel Disc Couplings

RINGFEDER® TND HDH

Standard Hubs, Double-Jointed, with Spacer,
Shaft-Hub Connection by Keyway

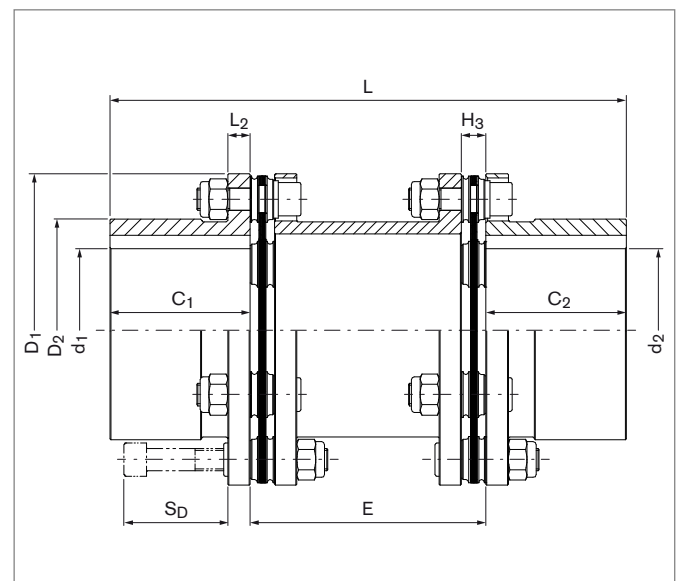

Size	T _{KNHD} ¹⁾	T _{KNHT} ¹⁾	n _{max} ²⁾	d _{pre} ³⁾	d _{1k;d_{2k}} max ⁴⁾	C ₁ / C ₂	E ⁵⁾	H ₃	D ₁	D ₂	L ₂	L	S _D	n _{sc}
HDH	Nm	Nm	1/min	mm	mm	mm	mm	mm	mm	mm	mm	mm	mm	Quantity
47	170	230	8400	10	32	39,5	60	7,5	70,5	47	5	139	24	6
							100					179		
							140					219		
63	320	420	6800	14	42	45	70	9	88	62,5	8	160	32	6
							80					170		
							100					190		
							140					230		
							100					210		
82	750	1050	5400	15	55	55	140	10,5	116	82	10	250	40	6
							180					290		
							100					220		
98	1350	1750	4600	19	65	60	140	12	140,5	98	11	260	47	6
							180					300		
							100					250		
118	2400	3000	3800	25	85	75	140	13	166,5	118	12	290	55	6
							180					330		
							140					320		
141	4000	5200	3400	30	95	90	180	15	198,5	141	14	360	64	6
							140					390		
							180					430		
169	6500	8500	3000	39	115	125	180	21	238	169	16	500	81	6
							250							

To continue see next page

Steel Disc Couplings RINGFEDER® TND HDH

Size	T _{KNHD} ¹⁾	T _{KNHT} ¹⁾	n _{max} ²⁾	d _{pre} ³⁾	d _{1k;d2k} max ⁴⁾	C ₁ / C ₂	E ⁵⁾	H ₃	D ₁	D ₂	L ₂	L	S _D	n _{sc}
HDH	Nm	Nm	1/min	mm	mm	mm	mm	mm	mm	mm	mm	mm	mm	Quantity
205	21000	26000	2500	59	140	160	200 250	28	295	205	22	520 570	112	8
254	36000	44000	2100	79	175	200	224 250 300	32,2	345	254	26	624 650 700	133	8
262	74000	---	1800	90	180	210	280	34	420	262	32	700	137	8
316	130000	---	1500	100	215	240	350	47	510	316	38	830	172	8

Size	E ⁵⁾	G _{WSB} ⁶⁾	J _{SB} ⁶⁾	C _{TdynHD}	C _{TdynHT}	Max. Permissible Misalignment ⁷⁾					
						axial		angular		radial	
HDH	mm	kg	10 ⁻⁹ kgm ²	10 ⁶ Nm/rad	10 ⁶ Nm/rad	ΔK _a HD	ΔK _a HT	ΔK _w HD	ΔK _w HT	ΔK _r HD	ΔK _r HT
						mm	mm	Degrees	Degrees	mm	mm
47	60	1,7	0,76	0,071	0,075	1,0	0,6	2	1,4	0,8	0,6
	100	1,8	0,76	0,059	0,062						
	140	1,9	0,76	0,071	0,075						
	Δ per 100 mm	0,31	0,14	0,14							
63	70	3,3	2,5	0,126	0,139	1,0	0,8	2	1,4	1	0,7
	80	3,3	2,6	0,123	0,134						
	100	3,5	2,7	0,116	0,127						
	140	3,7	2,8	0,105	0,114						
Δ per 100 mm	0,55	0,44	0,44								
82	100	7,1	9,1	0,271	0,308	1,4	0,8	2	1,4	1,4	1,1
	140	7,4	9,5	0,246	0,277						
	180	7,7	9,9	0,226	0,251						
	Δ per 100 mm	0,74	0,10	1,06							
98	100	11,1	21	0,513	0,543	2,0	1,2	2	1,4	1,5	1
	140	11,5	22	0,469	0,494						
	180	12	23	0,433	0,454						
	Δ per 100 mm	1,09	1,04	2,18							
118	100	18,9	52	0,914	0,948	2,4	1,6	2	1,4	1,4	1
	140	19,6	54	0,855	0,884						
	180	20,3	56	0,803	0,829						
	Δ per 100 mm	1,74	5,14	5,24							
141	140	31,7	120	1,306	1,362	2,8	1,6	2	1,4	2	1,5
	180	32,5	130	1,229	1,279						
	Δ per 100 mm	1,92	8,14	8,3							
	169	140	60,2	340	2,467						
180	61,8	350	2,375	2,898							
250	64,5	360	2,231	2,686							
Δ per 100 mm	3,92	24,88	25,36								
205	200	119,6	1070	8,995	9,142	2,2	1,2	1	0,8	1,4	1,2
	250	122,4	1100	8,265	8,389						
	Δ per 100 mm	5,56	49,36	50,3							

To continue see next page

Steel Disc Couplings RINGFEDER ° TND HDH

Size	E ⁵⁾	Gw _{SB} ⁶⁾	J _{SB} ⁶⁾	C _{Tdyn} HD	C _{Tdyn} HT	Max. Permissible Misalignment ⁷⁾					
						axial		angular		radial	
HDH	mm	kg	10 ⁻³ kgm ²	10 ⁶ Nm/rad	10 ⁶ Nm/rad	ΔK _a HD	ΔK _a HT	ΔK _w HD	ΔK _w HT	ΔK _r HD	ΔK _r HT
						mm	mm	Degrees	Degrees	mm	mm
254	224	207,5	2620	14,975	15,19	2,2	1,6	1	0,8	1,6	1,3
	250	209,5	2640	14,302	14,497						
	300	213,3	2680	13,163	13,328						
	Δ per 100 mm	7,58	80,10	81,63							
262	280	261,9	5350	18,116	---	3,2	---	1	---	2,5	---
	Δ per 100 mm	8,75	121,28	122,81							
316	350	450,1	14430	36,134	---	3,8	---	1	---	3	---
	Δ per 100 mm	11,05	221,59	224,4							

- When selecting the size, it is essential to observe the instructions on coupling dimensioning in the document "Product Paper & Tech Paper RINGFEDER ° Steel Disc Couplings". Short-term peak torque T_{Kmax} is limited to 1.75 multiples of T_{KN}.
- For longer spacers, check bending critical rotational speed.
- Pre-bore has free tolerance.
- Maximum finished bore with keyways according to DIN 6885-1.
- Longer spacers on request. The figures given at "Δ per 100 mm" for Gw_{SB}, J_{SB}, C_{Tdyn}HD and C_{Tdyn}HT are approximate values.
- Weight and mass moments of inertia for pre-bored hubs.
- The maximum misalignment values must not apply simultaneously. The instructions on coupling dimensioning in the document "Product Paper & Tech Paper RINGFEDER ° Steel Disc Couplings" are to be observed.

Explanations

T _{KN} HD = Nom. transmissible torque with disc pack HD	D ₁ = Max. outer diameter	ΔK _a HD = Max. permissible axial misalignment with disc pack HD
T _{KN} HT = Nom. transmissible torque with disc pack HT	D ₂ = Outer diameter hub	ΔK _a HT = Max. permissible axial misalignment with disc pack HT
n _{max} = Max. rotational speed	L ₂ = Hub flange thickness	ΔK _w HD = Max. permissible angular misalignment with disc pack HD
d _{pre} = Diameter pre-bore	L = Total length	ΔK _w HT = Max. permissible angular misalignment with disc pack HT
d _{1kmax} = Max. bore diameter d ₁ with keyway acc. to DIN 6885-1	S _D = Disassembly space	ΔK _r HD = Max. permissible radial misalignment with disc pack HD
d _{2kmax} = Max. bore diameter d ₂ with keyway acc. to DIN 6885-1	n _{sc} = Quantity of screws	ΔK _r HT = Max. permissible radial misalignment with disc pack HT
C ₁ = Guided length in hub bore	Gw _{SB} = Weight at smallest bore diameter	
C ₂ = Guided length in hub bore	J _{SB} = Moment of inertia at smallest bore diameter.	
E = Distance between hubs	C _{Tdyn} HD = Dynamic torsional stiffness with disc pack HD	
H ₃ = Width of the disc pack	C _{Tdyn} HT = Dynamic torsional stiffness with disc pack HT	

Ordering example

Type	Size	Disc pack	Distance between hubs E	Bore diameter d ₁	Bore diameter d ₂
TND HDH	118	HT	140	60	80

Further information on RINGFEDER ° TND HDH on www.ringfeder.com

BIBUS
SUPPORTING YOUR SUCCESS

BIBUS SK, s.r.o.
Trnavská 31, SK-94 901 Nitra

Tel.: 037/ 7777 911 Email: sale@bibus.sk
Fax.: 037/ 7777 999 <http://www.bibus.sk>

Technical Information

- Without further specifications, we deliver as standard: Bore tolerance H7; Keyway acc. to DIN 6885-1; Keyway width tolerance P9; Set screw per hub.
- From a peripheral speed of 30 m/s, separate balancing of the individual coupling parts is recommended.
- Without further instructions on balancing, the coupling parts are balanced individually according to DIN 21940-11 in quality G 6,3 at 1,500 1/min. The hubs are balanced half key (before grooving), the spacer without screwed-on disc packs.

Disclaimer of liability

All technical details and notes are non-binding and cannot be used as a basis for legal claims. The user is obligated to determine whether the represented products meet his requirements. We reserve the right to carry out modifications at any time in the interests of technical progress.