

BIBUS

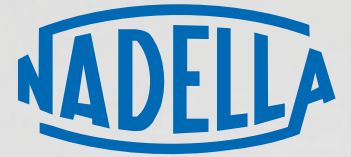

TELESCOPIC-LINE

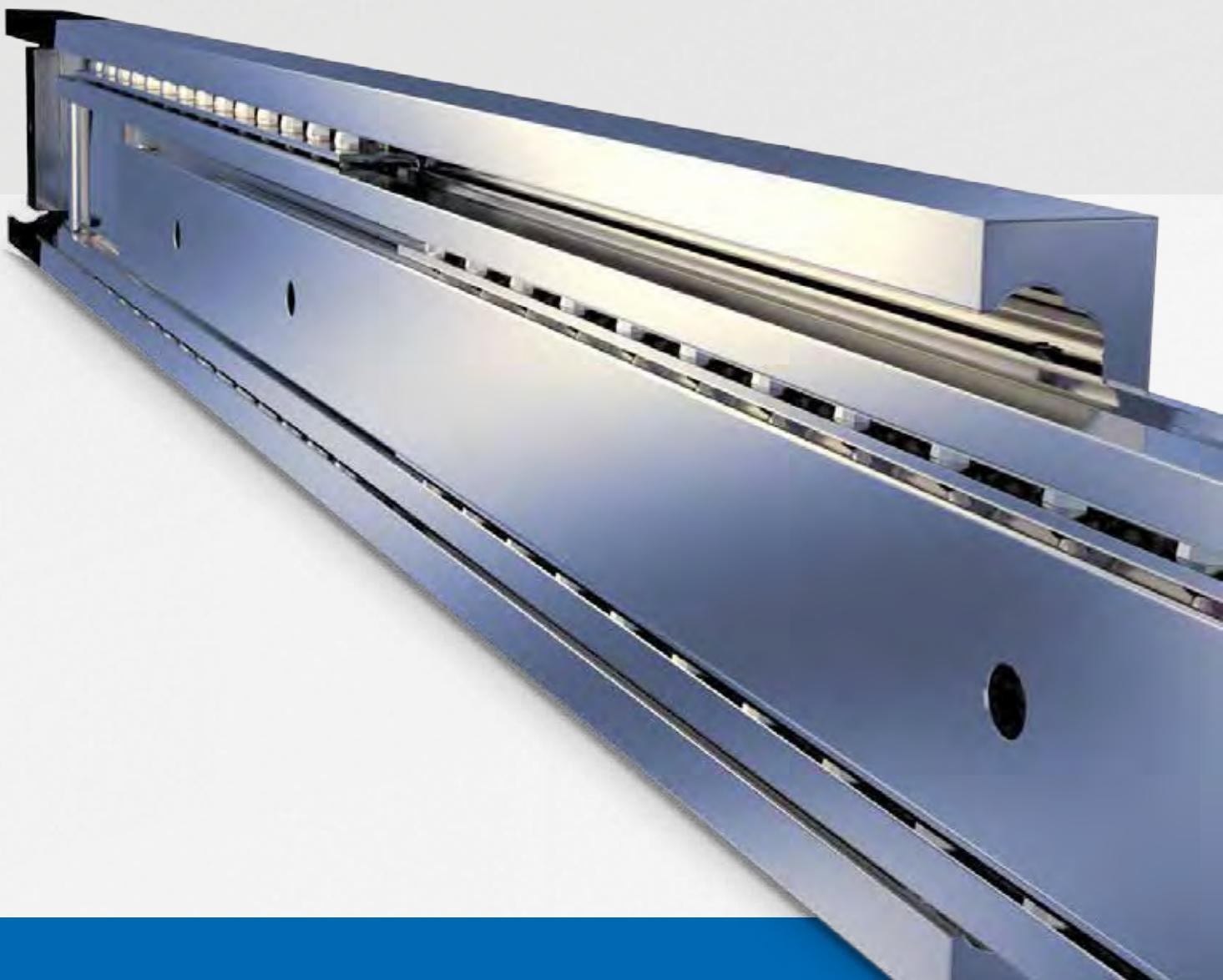

SUMMARY

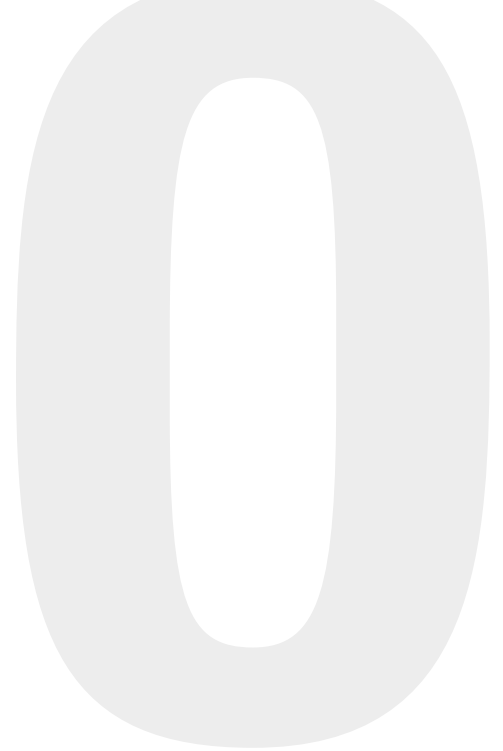

PAGE 4	1.0 COMPANY
PAGE 9	2.0 PART EXTENSIONS
PAGE 27	3.0 FULL EXTENSIONS
PAGE 53	4.0 HEAVY DUTY EXTENSIONS
PAGE 75	5.0 OVER EXTENSIONS
PAGE 93	6.0 LINEAR GUIDES
PAGE 105	7.0 TELESCOPIC LINE: HARDENED TELESCOPIC RAILS FOR HIGHLY DYNAMIC APPLICATIONS
PAGE 133	8.0 GENERAL INFORMATION <ul style="list-style-type: none">• Technical information• Applications• Order code

THE NADELLA COMPANY

THE SPECIALIST FOR MOTION TECHNOLOGY

NADELLA has developed over time from a supplier of rolling bearings, linear guide components and linear axes into an expert system partner for all areas of motion technology. Wherever innovative ideas, precision and reliability are required, developers and design engineers rely on products from NADELLA. Our customers now include renowned mechanical engineering, plant construction and automation engineering companies in Germany, Europe, Asia and the USA.

FULL SERVICE AND JUST IN TIME

We consider ourselves to be a full-service partner – from development of a product through production and all the way to logistics. Our established network guarantees efficient processes in all areas and throughout the value-added chain – all from a single source. Additionally, express deliveries or fast and inexpensive special treatment of catalogue parts is also possible. This also applies to small and medium quantities.

EXPERIENCE AND KNOW-HOW

Professional operations and application consultation are just a few of our distinguishing characteristics: Our consulting engineers collaborate closely with our customers' experts, actively contributing their specialist expertise, their experience and the technical possibilities. This results in custom solutions that set standards.

MAXIMUM QUALITY AND CERTIFIED ENVIRONMENTAL MANAGEMENT

Maximum quality is our top priority. That is why every process step is accompanied and regularly checked by expert employees. All companies and plants are certified according to DIN EN ISO 9001 or ISO/TS 16949, and their environmental management systems comply with DIN EN ISO 14001. We also have the latest measuring and testing equipment at our disposal to ensure that our high quality standards are met over the long term.

- CAQ system
- 3-D CNC measuring machines
- Force testing
- Radiographic inspection
- Microsection analysis
- Materials testing on metal and plastic



WORLDWIDE NETWORK FOR IDEAL SERVICE

MANY PATHS LEAD TO NADELLA – AND THEY ARE SHORT ANYWHERE IN THE WORLD.

Our customers' satisfaction is the basis for our success and growth. That is why we are at your service around the world and always keep your requirements in mind. We now possess a worldwide network of distributors in all important industrialised countries in Europe, Asia and the USA. This allows us to ensure customer-orientated consultation, delivery and service at all times.



NADELLA MAIN OFFICES

China
Germany
Italy
USA

DURBAL HEAD OFFICE

Germany

BRANCHES AND DISTRIBUTORS

Belgium	Romania
Brazil	Sweden
Denmark	Switzerland
Finland	Singapore
France	Slovakia
Great Britain	Slovenia
India	Spain
Korea	Taiwan
Netherlands	Czech Republic
Norway	Turkey
Austria	Hungary
Poland	





PART EXTENSIONS



PAGE 10

2.1 PRODUCT OVERVIEW

PAGE 12

2.2 PART EXTENSIONS

- NTA27-14T
- NTA33-15
- NTA40-18.5
- NTA48-15T
- NTA50-19.5
- NTA59-17.5T
- NTA60-20
- NTA70-21
- NTA72-21.5T
- NTA80-22
- NTA100-26
- NTA120-31
- NTA150-35

PRODUCT OVERVIEW

PART EXTENSIONS

NTA27-14T

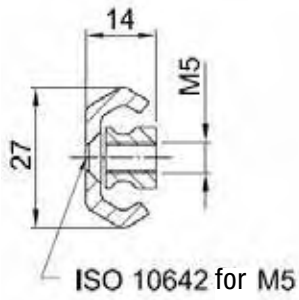

NTA33-15

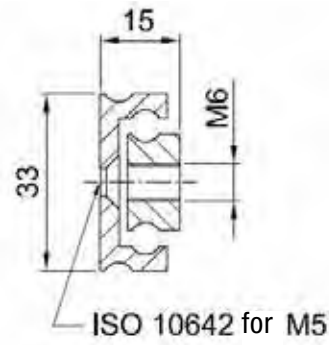

NTA40-18.5

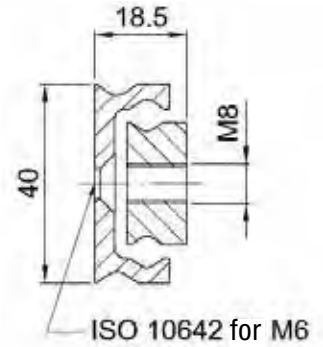

NTA48-15T

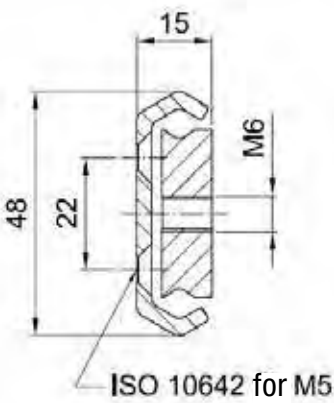

NTA50-19.5

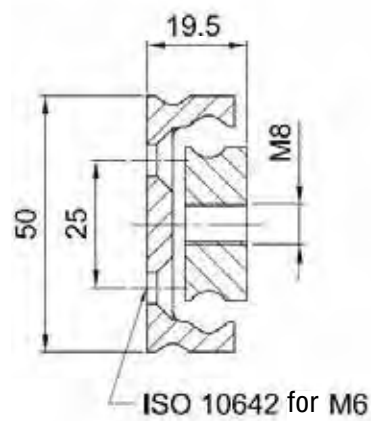

NTA59-17.5T

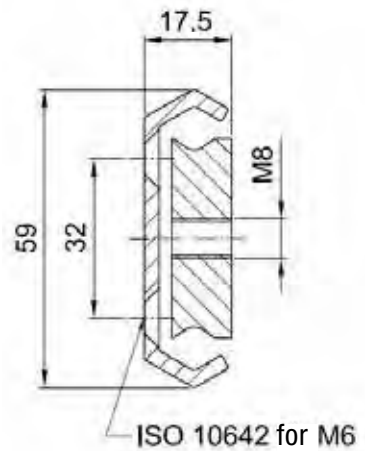

NTA60-20

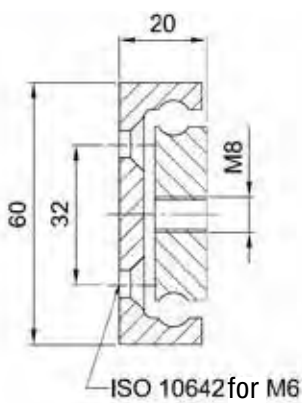

NTA70-21

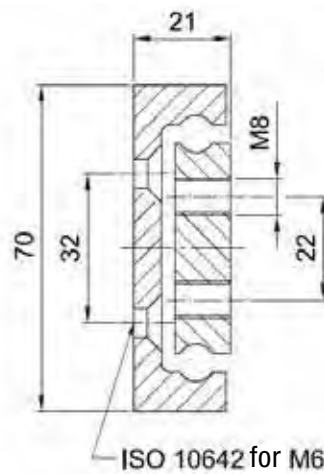

NTA72-21.5T

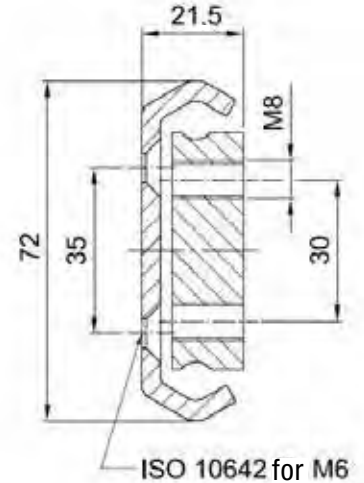

PART EXTENSIONS

NTA80-22

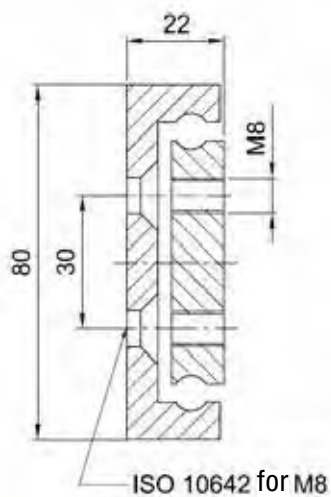

NTA100-26

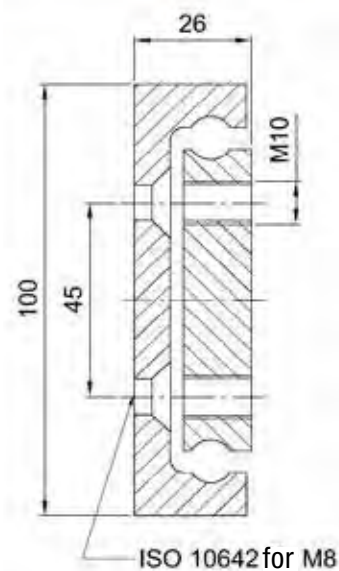

NTA120-31

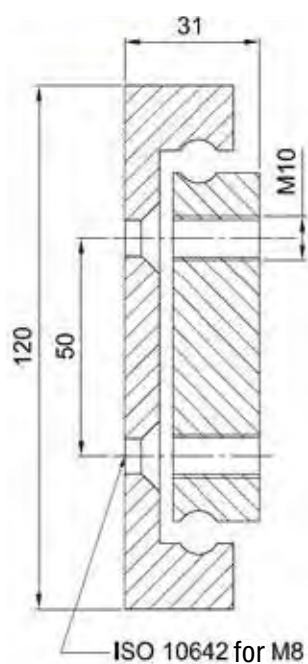

NTA150-35

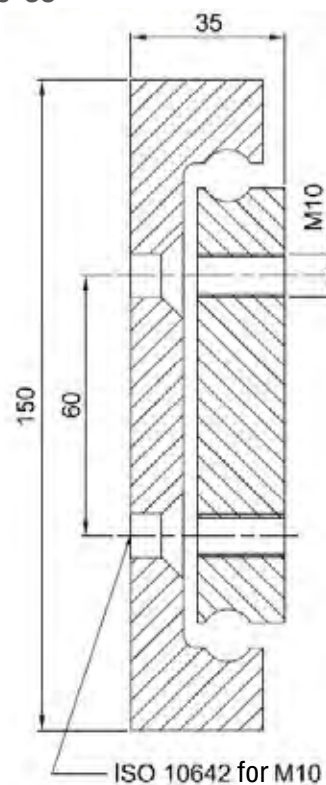

PART EXTENSION

NTA27-14T

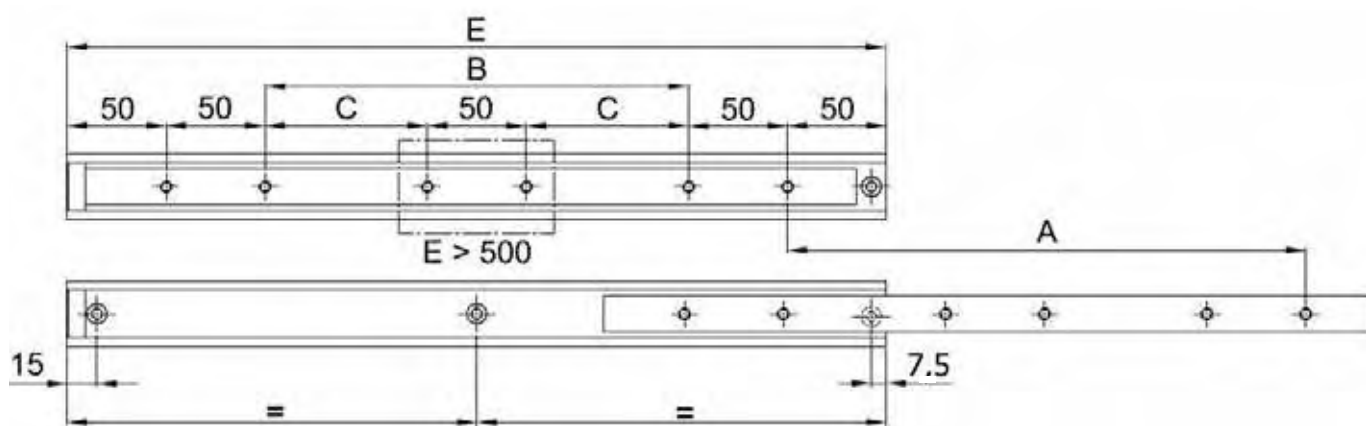
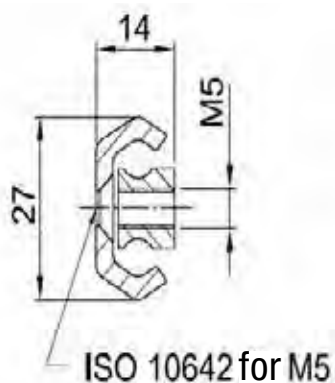

Load Table

Order Number	Hole separation (mm)		Installation length (mm)	Extension length (mm)	Net weight (kg)	Maximum load/pair (N)
	B	C	E	A		
NTA27-14T-250	50		250	130	0.5	710
NTA27-14T-300	100		300	180	0.6	770
NTA27-14T-350	150		350	230	0.7	770
NTA27-14T-400	200		400	260	0.8	710
NTA27-14T-450	250		450	310	0.9	660
NTA27-14T-500	300		500	340	1.0	610
NTA27-14T-550		150	550	370	1.1	560
NTA27-14T-600		175	600	400	1.2	510
NTA27-14T-650		200	650	430	1.3	460
NTA27-14T-700		225	700	460	1.4	410
NTA27-14T-750		250	750	490	1.5	360
NTA27-14T-800		275	800	520	1.6	310
NTA27-14T-850		300	850	550	1.6	260
NTA27-14T-900		325	900	600	1.7	230
NTA27-14T-950		350	950	630	1.8	210
NTA27-14T-1000		375	1000	660	1.9	190

Ordercode and further options see last page. Your desired length is not listed in the table? No problem! Only the most common lengths are shown here. Please contact our application technology division.

NTA33-15

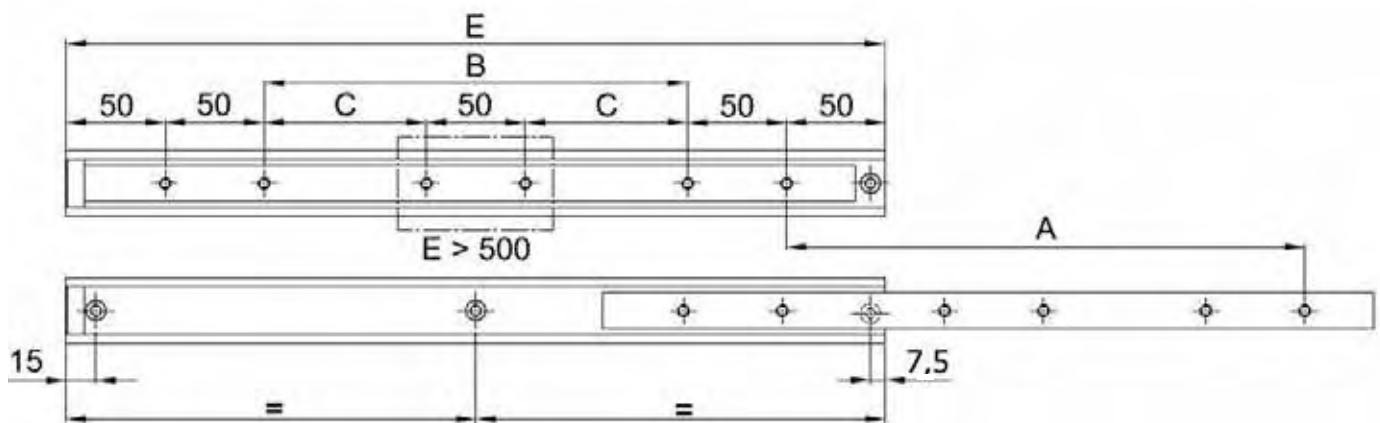
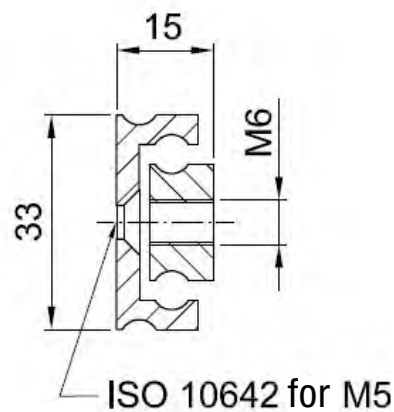

Load Table

Order Number	Hole separation (mm)		Installation length (mm)	Extension length (mm)	Net weight (kg)	Maximum load/pair (N)
	B	C				
NTA33-15-300	100		300	180	0.7	1200
NTA33-15-350	150		350	230	0.8	1150
NTA33-15-400	200		400	260	0.9	1100
NTA33-15-450	250		450	310	1.0	1050
NTA33-15-500	300		500	340	1.2	1000
NTA33-15-550		150	550	370	1.3	950
NTA33-15-600		175	600	400	1.4	900
NTA33-15-650		200	650	430	1.5	850
NTA33-15-700		225	700	460	1.6	800
NTA33-15-750		250	750	490	1.7	750
NTA33-15-800		275	800	520	1.9	700
NTA33-15-850		300	850	550	2.0	650
NTA33-15-900		325	900	600	2.1	600
NTA33-15-950		350	950	630	2.2	550
NTA33-15-1000		375	1000	660	2.4	500

Ordercode and further options see last page. Your desired length is not listed in the table? No problem! Only the most common lengths are shown here. Please contact our application technology division.

PART EXTENSION

NTA40-18.5

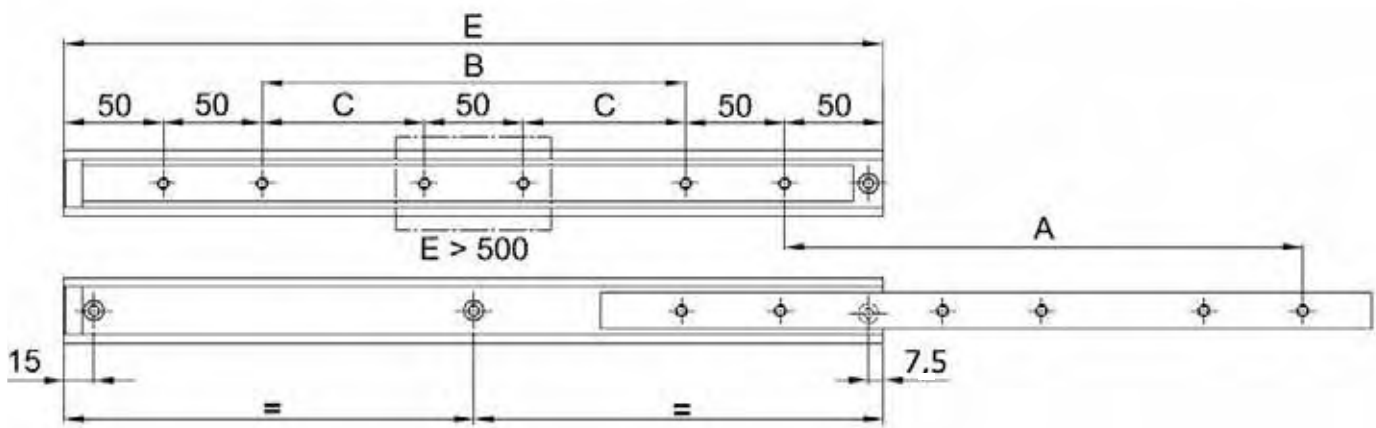
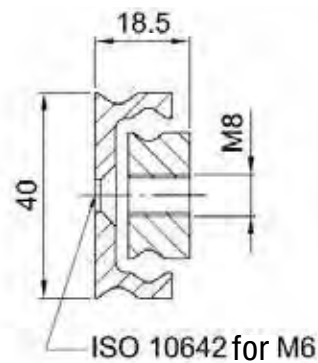

Load Table

Order Number	Hole separation (mm)		Installation length (mm)	Extension length (mm)	Net weight (kg)	Maximum load/pair (N)
	B	C	E	A		
NTA40-18.5-300	100		300	180	1.3	2000
NTA40-18.5-350	150		350	230	1.5	2350
NTA40-18.5-400	200		400	260	1.7	2450
NTA40-18.5-450	250		450	310	1.9	2550
NTA40-18.5-500	300		500	340	2.2	2500
NTA40-18.5-550		150	550	370	2.4	2450
NTA40-18.5-600		175	600	400	2.6	2400
NTA40-18.5-650		200	650	430	2.8	2350
NTA40-18.5-700		225	700	460	3.0	2300
NTA40-18.5-750		250	750	490	3.2	2250
NTA40-18.5-800		275	800	520	3.5	2150
NTA40-18.5-850		300	850	550	3.7	2050
NTA40-18.5-900		325	900	600	3.9	1950
NTA40-18.5-950		350	950	630	4.1	1800
NTA40-18.5-1000		375	1000	660	4.3	1700
NTA40-18.5-1100		425	1100	720	4.7	1600
NTA40-18.5-1200		475	1200	800	5.1	1500

Ordercode and further options see last page. Your desired length is not listed in the table? No problem! Only the most common lengths are shown here. Please contact our application technology division.

NTA48-15T

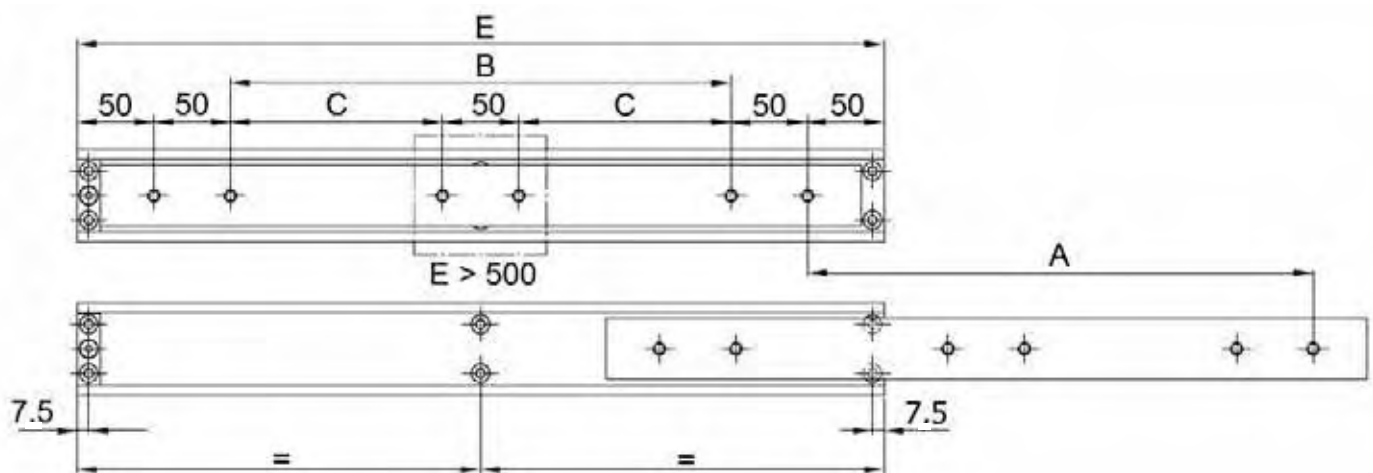
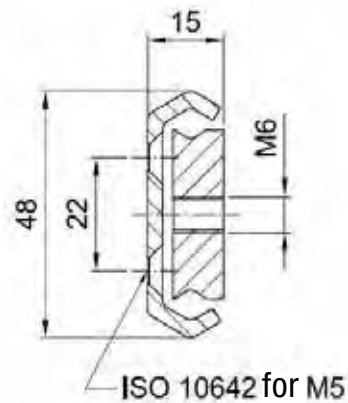

Load Table

Order Number	Hole separation (mm)		Installation length (mm)	Extension length (mm)	Net weight (kg)	Maximum load/pair (N)
	B	C	E	A		
NTA48-15T-300	100		300	180	1.0	1550
NTA48-15T-350	150		350	230	1.2	1650
NTA48-15T-400	200		400	260	1.4	1750
NTA48-15T-450	250		450	310	1.6	1850
NTA48-15T-500	300		500	340	1.8	1800
NTA48-15T-550		150	550	370	1.9	1750
NTA48-15T-600		175	600	400	2.1	1700
NTA48-15T-650		200	650	430	2.2	1650
NTA48-15T-700		225	700	460	2.4	1600
NTA48-15T-750		250	750	490	2.6	1500
NTA48-15T-800		275	800	520	2.7	1400
NTA48-15T-850		300	850	550	2.9	1300
NTA48-15T-900		325	900	600	3.1	1200
NTA48-15T-950		350	950	630	3.3	1100
NTA48-15T-1000		375	1000	660	3.5	1000
NTA48-15T-1100		425	1100	720	3.7	800
NTA48-15T-1200		475	1200	800	4.1	600

Ordercode and further options see last page. Your desired length is not listed in the table? No problem! Only the most common lengths are shown here. Please contact our application technology division.

PART EXTENSION

NTA50-19.5

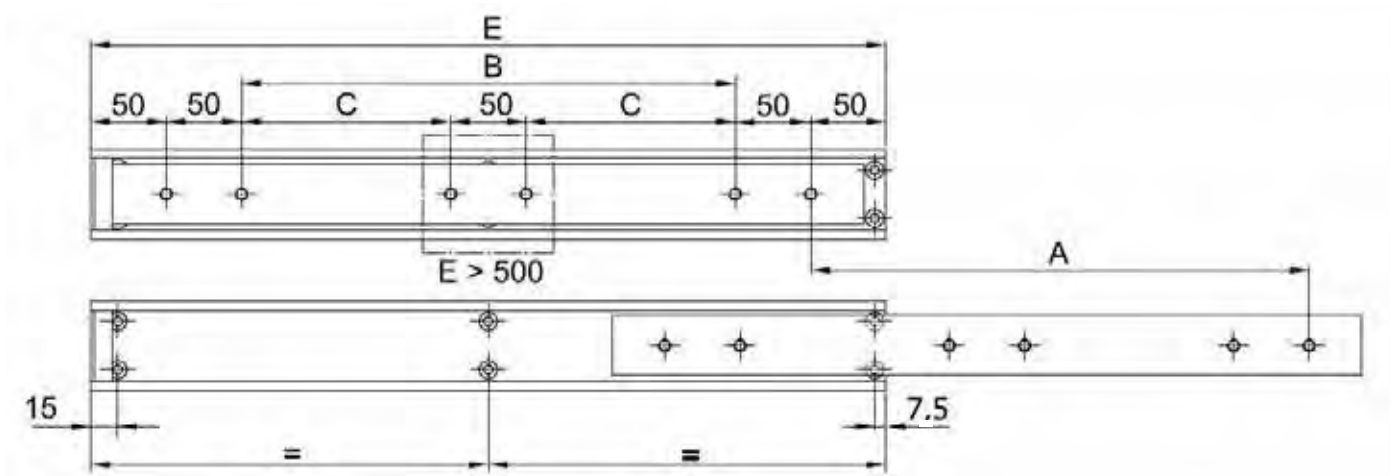
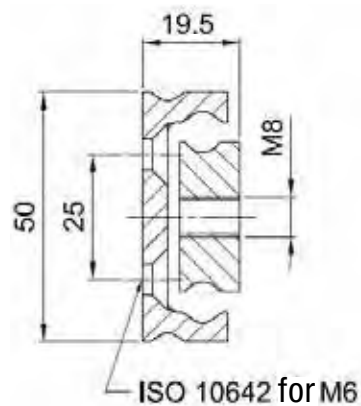

Load Table

Order Number	Hole separation (mm)		Installation length (mm)	Extension length (mm)	Net weight (kg)	Maximum load/pair (N)
	B	C	E	A		
NTA50-19.5-300	100		300	180	1.7	2400
NTA50-19.5-350	150		350	230	2.0	2600
NTA50-19.5-400	200		400	260	2.2	2700
NTA50-19.5-450	250		450	310	2.5	2800
NTA50-19.5-500	300		500	340	2.8	2900
NTA50-19.5-550		150	550	370	3.1	2850
NTA50-19.5-600		175	600	400	3.4	2800
NTA50-19.5-650		200	650	430	3.6	2700
NTA50-19.5-700		225	700	460	3.9	2600
NTA50-19.5-750		250	750	490	4.2	2500
NTA50-19.5-800		275	800	520	4.5	2400
NTA50-19.5-850		300	850	550	4.8	2300
NTA50-19.5-900		325	900	600	5.1	2200
NTA50-19.5-950		350	950	630	5.3	2100
NTA50-19.5-1000		375	1000	660	5.6	2000
NTA50-19.5-1100		425	1100	720	6.2	1850
NTA50-19.5-1200		475	1200	800	6.7	1650

Ordercode and further options see last page. Your desired length is not listed in the table? No problem! Only the most common lengths are shown here. Please contact our application technology division.

NTA59-17.5T

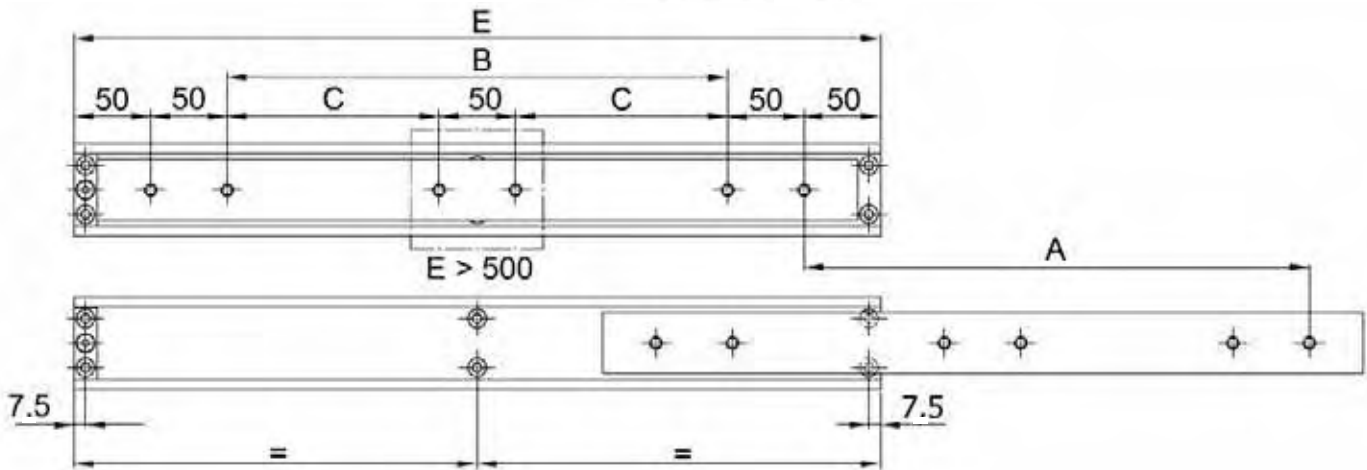
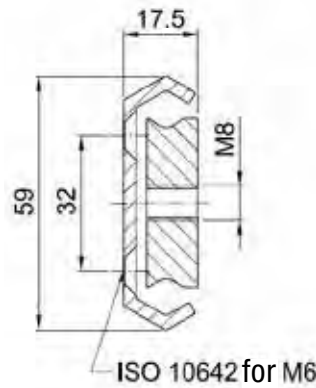

Load Table

Order Number	Hole separation (mm)		Installation length (mm)	Extension length (mm)	Net weight (kg)	Maximum load/pair (N)
	B	C				
NTA59-17.5T-300	100		300	180	2.0	2250
NTA59-17.5T-350	150		350	230	2.3	2350
NTA59-17.5T-400	200		400	260	2.6	2450
NTA59-17.5T-450	250		450	310	2.9	2550
NTA59-17.5T-500	300		500	340	3.1	2500
NTA59-17.5T-550		150	550	370	3.6	2450
NTA59-17.5T-600		175	600	400	3.8	2400
NTA59-17.5T-650		200	650	430	4.2	2350
NTA59-17.5T-700		225	700	460	4.5	2250
NTA59-17.5T-750		250	750	490	4.8	2150
NTA59-17.5T-800		275	800	520	5.2	2050
NTA59-17.5T-850		300	850	550	5.5	1950
NTA59-17.5T-900		325	900	600	5.8	1850
NTA59-17.5T-950		350	950	630	6.1	1750
NTA59-17.5T-1000		375	1000	660	6.4	1650
NTA59-17.5T-1100		425	1100	720	7.1	1450
NTA59-17.5T-1200		475	1200	800	7.7	1200
NTA59-17.5T-1300		525	1300	860	8.3	1050
NTA59-17.5T-1400		575	1400	920	9.0	850
NTA59-17.5T-1500		625	1500	1000	9.6	650

Ordercode and further options see last page. Your desired length is not listed in the table? No problem! Only the most common lengths are shown here. Please contact our application technology division.

PART EXTENSION

NTA60-20

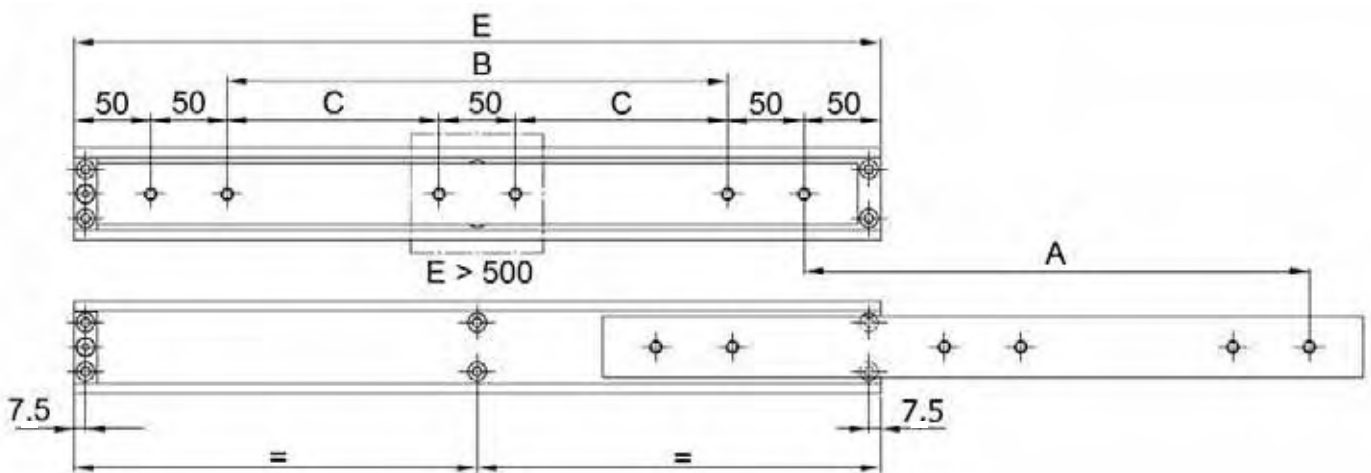
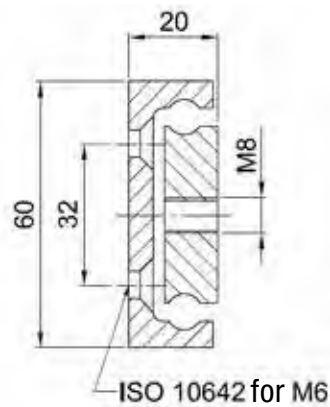

Load Table

Order Number	Hole separation (mm)		Installation length (mm)	Extension length (mm)	Net weight (kg)	Maximum load/pair (N)
	B	C	E	A		
NTA60-20-300	100		300	180	2.3	3200
NTA60-20-350	150		350	210	2.7	3250
NTA60-20-400	200		400	240	3.1	3300
NTA60-20-450	250		450	270	3.5	3350
NTA60-20-500	300		500	300	3.9	3400
NTA60-20-550		150	550	330	4.3	3350
NTA60-20-600		175	600	360	4.6	3300
NTA60-20-650		200	650	390	5.0	3250
NTA60-20-700		225	700	420	5.4	3200
NTA60-20-750		250	750	450	5.8	3100
NTA60-20-800		275	800	480	6.1	3000
NTA60-20-850		300	850	510	6.5	2900
NTA60-20-900		325	900	540	6.9	2800
NTA60-20-950		350	950	570	7.3	2700
NTA60-20-1000		375	1000	600	7.7	2600
NTA60-20-1100		425	1100	660	8.5	2450
NTA60-20-1200		475	1200	720	9.2	2250
NTA60-20-1300		525	1300	780	10.0	2050
NTA60-20-1400		575	1400	840	10.8	1900
NTA60-20-1500		625	1500	900	11.6	1700

Ordercode and further options see last page. Your desired length is not listed in the table? No problem! Only the most common lengths are shown here. Please contact our application technology division.

NTA70-21

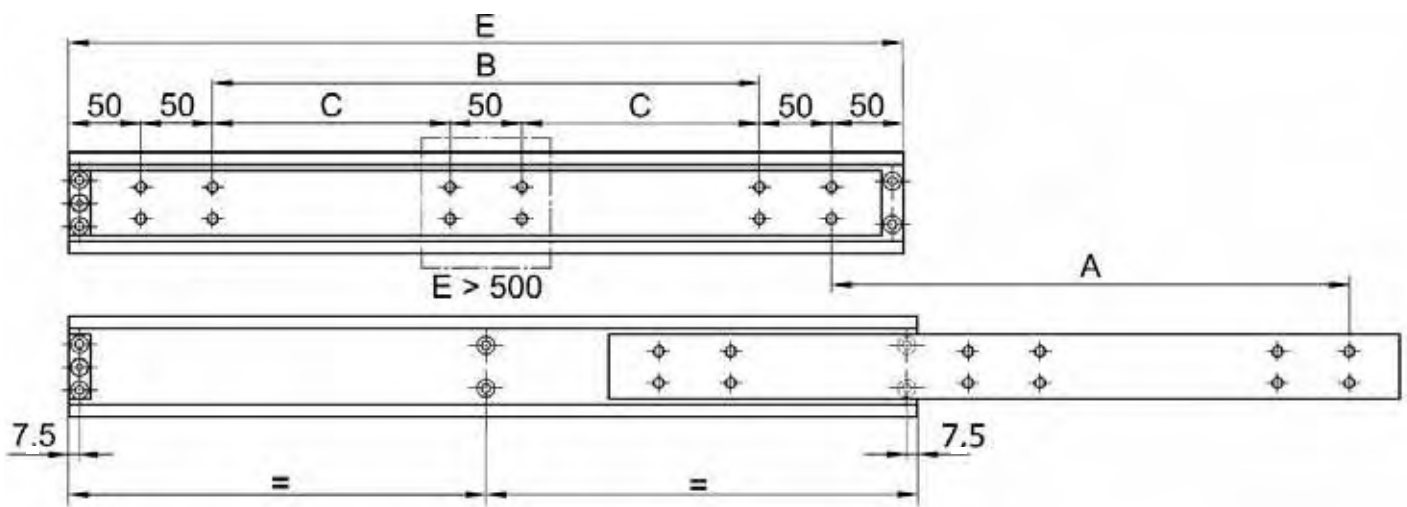
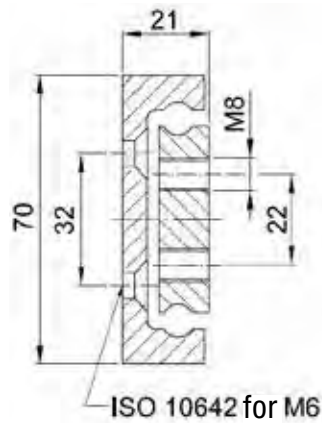

Load Table

Order Number	Hole separation (mm)		Installation length (mm)	Extension length (mm)	Net weight (kg)	Maximum load/pair (N)
	B	C				
NTA70-21-500	300		500	300	4.5	4200
NTA70-21-550		150	550	330	5.0	4150
NTA70-21-600		175	600	360	5.5	4100
NTA70-21-650		200	650	390	6.0	4050
NTA70-21-700		225	700	420	6.5	4000
NTA70-21-750		250	750	450	6.9	3900
NTA70-21-800		275	800	480	7.4	3800
NTA70-21-850		300	850	510	7.8	3700
NTA70-21-900		325	900	540	8.3	3600
NTA70-21-950		350	950	570	8.8	3450
NTA70-21-1000		375	1000	600	9.3	3300
NTA70-21-1100		425	1100	660	10.2	3100
NTA70-21-1200		475	1200	720	11.1	2900
NTA70-21-1300		525	1300	780	12.0	2700
NTA70-21-1400		575	1400	840	12.9	2400
NTA70-21-1500		625	1500	900	13.9	2100
NTA70-21-1600		675	1600	960	14.8	1800
NTA70-21-1700		725	1700	1020	15.7	1500

Ordercode and further options see last page. Your desired length is not listed in the table? No problem! Only the most common lengths are shown here. Please contact our application technology division.

PART EXTENSION

NTA72-21.5T

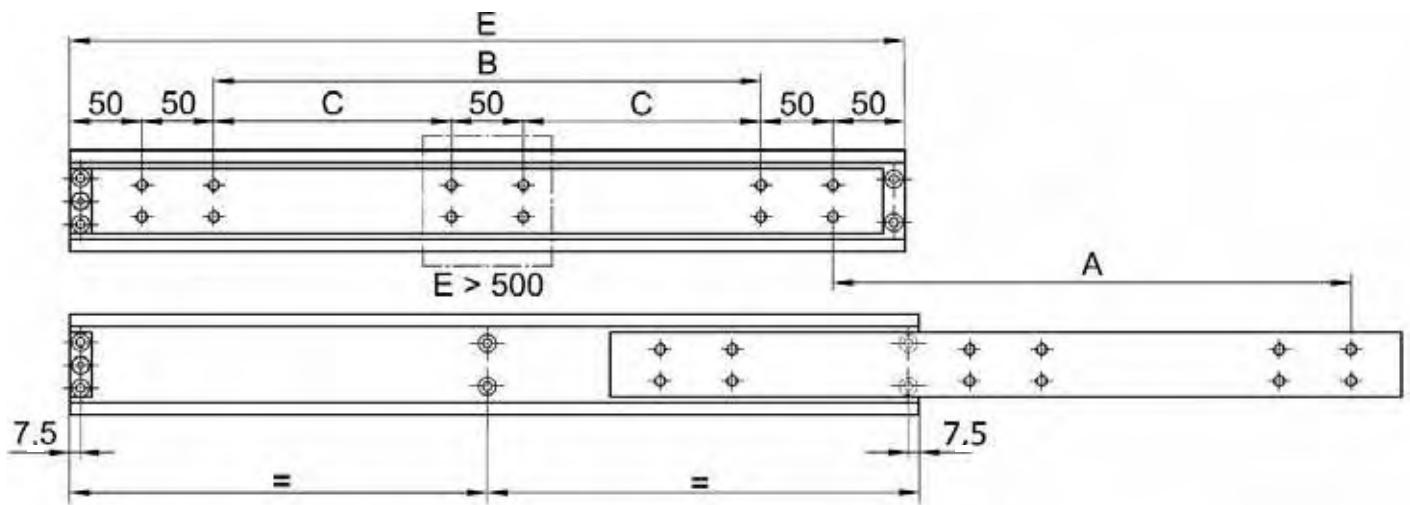
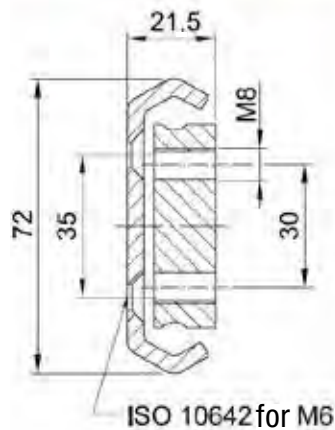

Load Table

Order Number	Hole separation (mm)		Installation length (mm)	Extension length (mm)	Net weight (kg)	Maximum load/pair (N)
	B	C				
NTA72-21.5T-400	200		400	240	3.2	2850
NTA72-21.5T-450	250		450	270	3.6	3000
NTA72-21.5T-500	300		500	300	4.0	2950
NTA72-21.5T-550		150	550	330	4.5	3050
NTA72-21.5T-600		175	600	360	4.9	3000
NTA72-21.5T-650		200	650	390	5.2	2950
NTA72-21.5T-700		225	700	420	5.6	2900
NTA72-21.5T-750		250	750	450	6.0	2850
NTA72-21.5T-800		275	800	480	6.3	2800
NTA72-21.5T-850		300	850	510	6.8	2750
NTA72-21.5T-900		325	900	540	7.2	2700
NTA72-21.5T-950		350	950	570	7.8	2650
NTA72-21.5T-1000		375	1000	600	8.0	2550
NTA72-21.5T-1100		425	1100	660	8.8	2300
NTA72-21.5T-1200		475	1200	720	9.6	2050
NTA72-21.5T-1300		525	1300	780	10.4	1800
NTA72-21.5T-1400		575	1400	840	11.2	1550
NTA72-21.5T-1500		625	1500	900	12.2	1250
NTA72-21.5T-1600		675	1600	960	12.8	950
NTA72-21.5T-1700		725	1700	1020	13.5	750

Ordercode and further options see last page. Your desired length is not listed in the table? No problem! Only the most common lengths are shown here. Please contact our application technology division.

NTA80-22

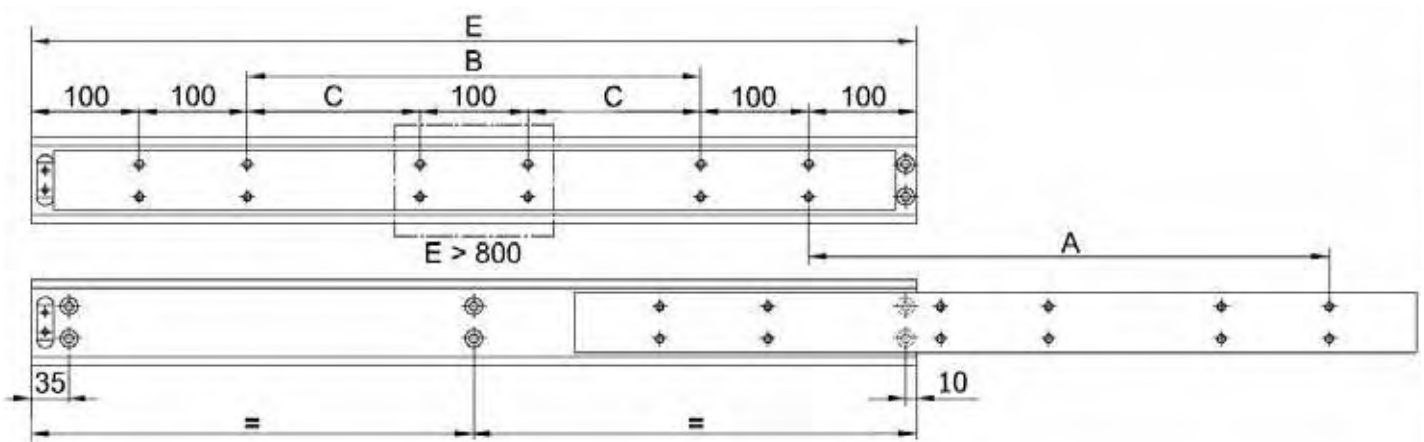
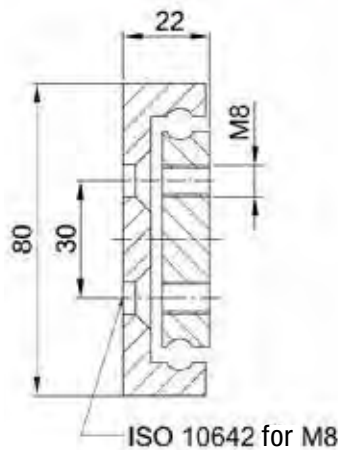

Load Table

Order Number	Hole separation (mm)		Installation length (mm)	Extension length (mm)	Net weight (kg)	Maximum load/pair (N)
	B	C	E	A		
NTA80-22-500	100		500	300	5.2	4800
NTA80-22-550	150		550	330	5.7	4900
NTA80-22-600	200		600	360	6.2	5000
NTA80-22-650	250		650	390	6.7	4900
NTA80-22-700	300		700	420	7.3	4800
NTA80-22-750	350		750	450	7.7	4700
NTA80-22-800	400		800	480	8.3	4600
NTA80-22-850		175	850	510	8.8	4500
NTA80-22-900		200	900	540	9.3	4400
NTA80-22-950		225	950	570	9.8	4250
NTA80-22-1000		250	1000	600	10.4	4100
NTA80-22-1100		300	1100	660	11.4	3800
NTA80-22-1200		350	1200	720	12.4	3500
NTA80-22-1300		400	1300	780	13.5	3200
NTA80-22-1400		450	1400	840	14.5	2900
NTA80-22-1500		500	1500	900	15.6	2600
NTA80-22-1600		550	1600	960	16.6	2300
NTA80-22-1700		600	1700	1020	17.7	2000

Ordercode and further options see last page. Your desired length is not listed in the table? No problem! Only the most common lengths are shown here. Please contact our application technology division.

PART EXTENSION

NTA100-26

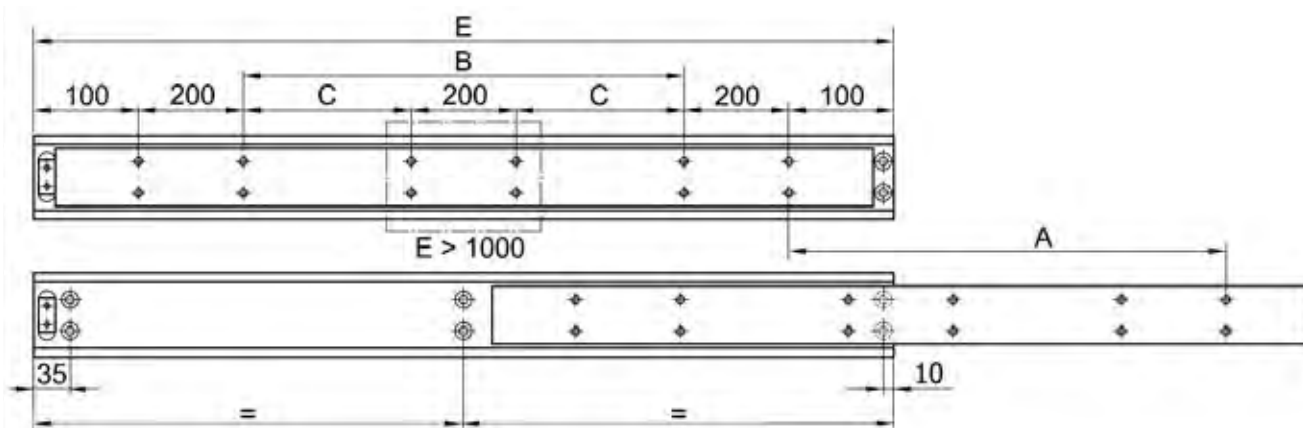
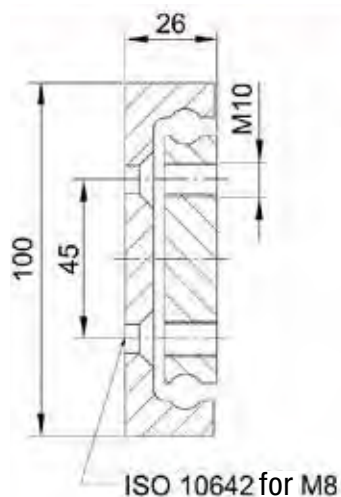

Load Table

Order Number	Hole separation (mm)		Installation length (mm)	Extension length (mm)	Net weight (kg)	Maximum load/pair (N)
	B	C				
NTA100-26-700	100		700	420	12.0	9000
NTA100-26-750	150		750	450	12.8	9500
NTA100-26-800	200		800	480	13.6	10000
NTA100-26-850	250		850	510	14.0	9750
NTA100-26-900	300		900	540	15.4	9500
NTA100-26-950	350		950	570	16.2	9250
NTA100-26-1000	400		1000	600	17.0	9000
NTA100-26-1100		150	1100	660	18.7	8500
NTA100-26-1200		200	1200	720	20.4	8000
NTA100-26-1300		250	1300	780	22.1	7500
NTA100-26-1400		300	1400	840	27.8	6900
NTA100-26-1500		350	1500	900	25.5	6300
NTA100-26-1600		400	1600	960	27.2	5700
NTA100-26-1700		450	1700	1020	28.9	5100
NTA100-26-1800		500	1800	1080	30.6	4500
NTA100-26-1900		550	1900	1140	32.3	3900
NTA100-26-2000		600	2000	1200	34.0	3300

Ordercode and further options see last page. Your desired length is not listed in the table? No problem! Only the most common lengths are shown here. Please contact our application technology division.

NTA120-31

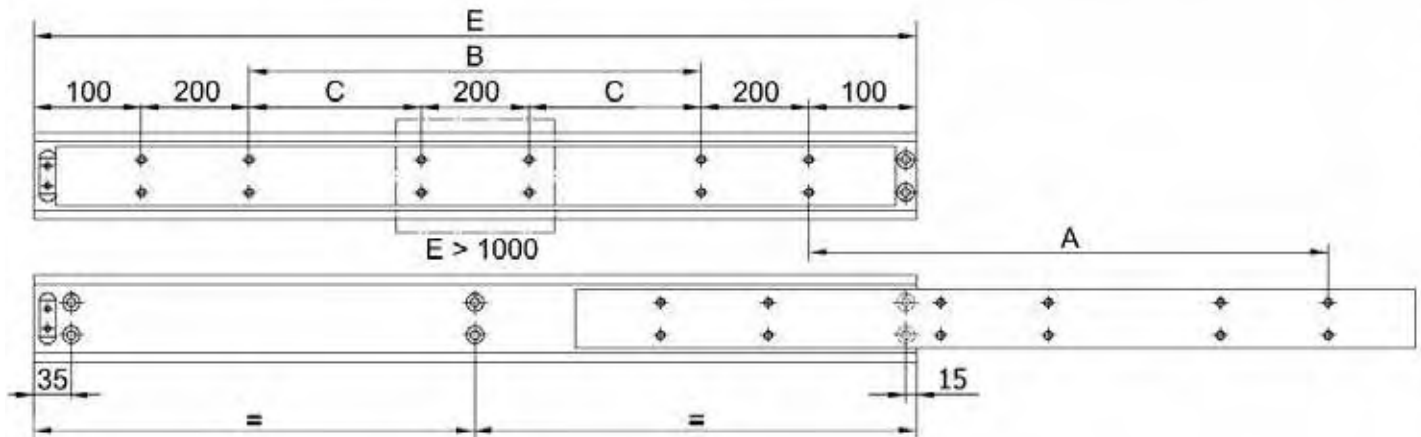
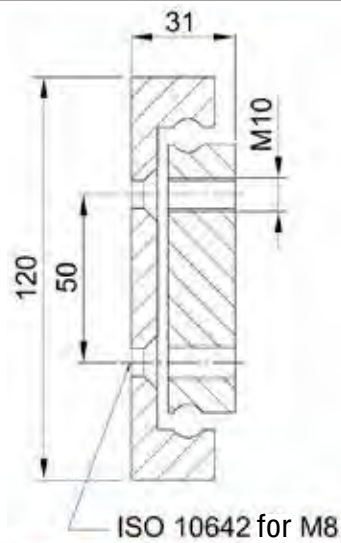

Load Table

Order Number	Hole separation (mm)		Installation length (mm)	Extension length (mm)	Net weight (kg)	Maximum load/pair (N)
	B	C				
NTA120-31-700	100		700	420	16.6	11500
NTA120-31-750	150		750	450	17.8	12000
NTA120-31-800	200		800	480	19.0	12000
NTA120-31-850	250		850	510	20.2	12000
NTA120-31-900	300		900	540	21.4	11700
NTA120-31-950	350		950	570	22.5	11400
NTA120-31-1000	400		1000	600	23.7	11000
NTA120-31-1100		150	1100	660	26.1	10800
NTA120-31-1200		200	1200	720	28.5	10300
NTA120-31-1300		250	1300	780	30.8	9800
NTA120-31-1400		300	1400	840	33.2	9300
NTA120-31-1500		350	1500	900	35,6	8700
NTA120-31-1600		400	1600	960	38.0	8100
NTA120-31-1700		450	1700	1020	40.3	7400
NTA120-31-1800		500	1800	1080	42.7	6700
NTA120-31-1900		550	1900	1140	45.1	5700
NTA120-31-2000		600	2000	1200	47.5	4700
NTA120-31-2100		650	2100	1260	49.4	3700

Ordercode and further options see last page. Your desired length is not listed in the table? No problem! Only the most common lengths are shown here. Please contact our application technology division.

PART EXTENSION

NTA150-35

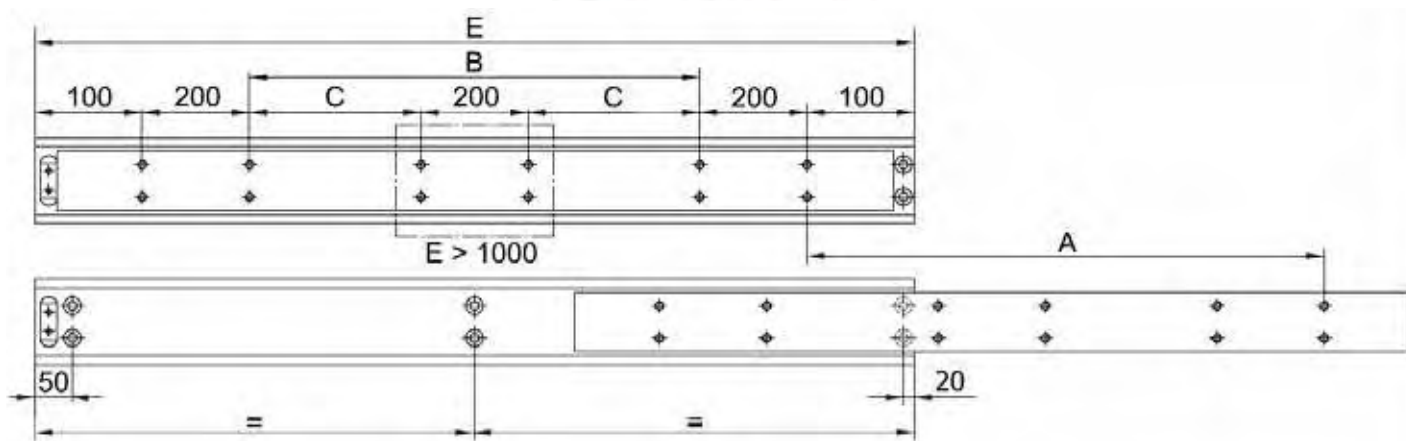
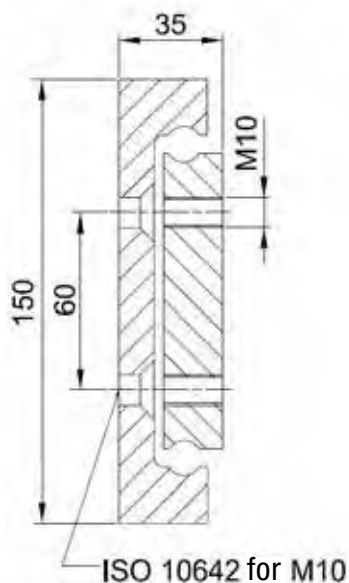

Load Table

Order Number	Hole separation (mm)		Installation length (mm)	Extension length (mm)	Net weight (kg)	Maximum load/pair (N)
	B	C				
NTA150-35-700	100		700	420	24.2	14500
NTA150-35-750	150		750	450	25.9	15000
NTA150-35-800	200		800	480	27.7	15500
NTA150-35-850	250		850	510	29.4	15500
NTA150-35-900	300		900	540	31.1	15000
NTA150-35-950	350		950	570	32.9	14750
NTA150-35-1000	400		1000	600	34.6	14500
NTA150-35-1100		150	1100	660	38.0	14100
NTA150-35-1200		200	1200	720	41.5	13300
NTA150-35-1300		250	1300	780	45.0	12500
NTA150-35-1400		300	1400	840	48.4	11700
NTA150-35-1500		350	1500	900	51.9	10900
NTA150-35-1600		400	1600	960	55.3	10000
NTA150-35-1700		450	1700	1020	58.8	9100
NTA150-35-1800		500	1800	1080	62.3	8200
NTA150-35-1900		550	1900	1140	65.7	7300
NTA150-35-2000		600	2000	1200	69.1	6400
NTA150-35-2100		650	2100	1260	71.9	5500
NTA150-35-2200		700	2200	1320	75.3	4500

Ordercode and further options see last page. Your desired length is not listed in the table? No problem! Only the most common lengths are shown here. Please contact our application technology division.

NOTES

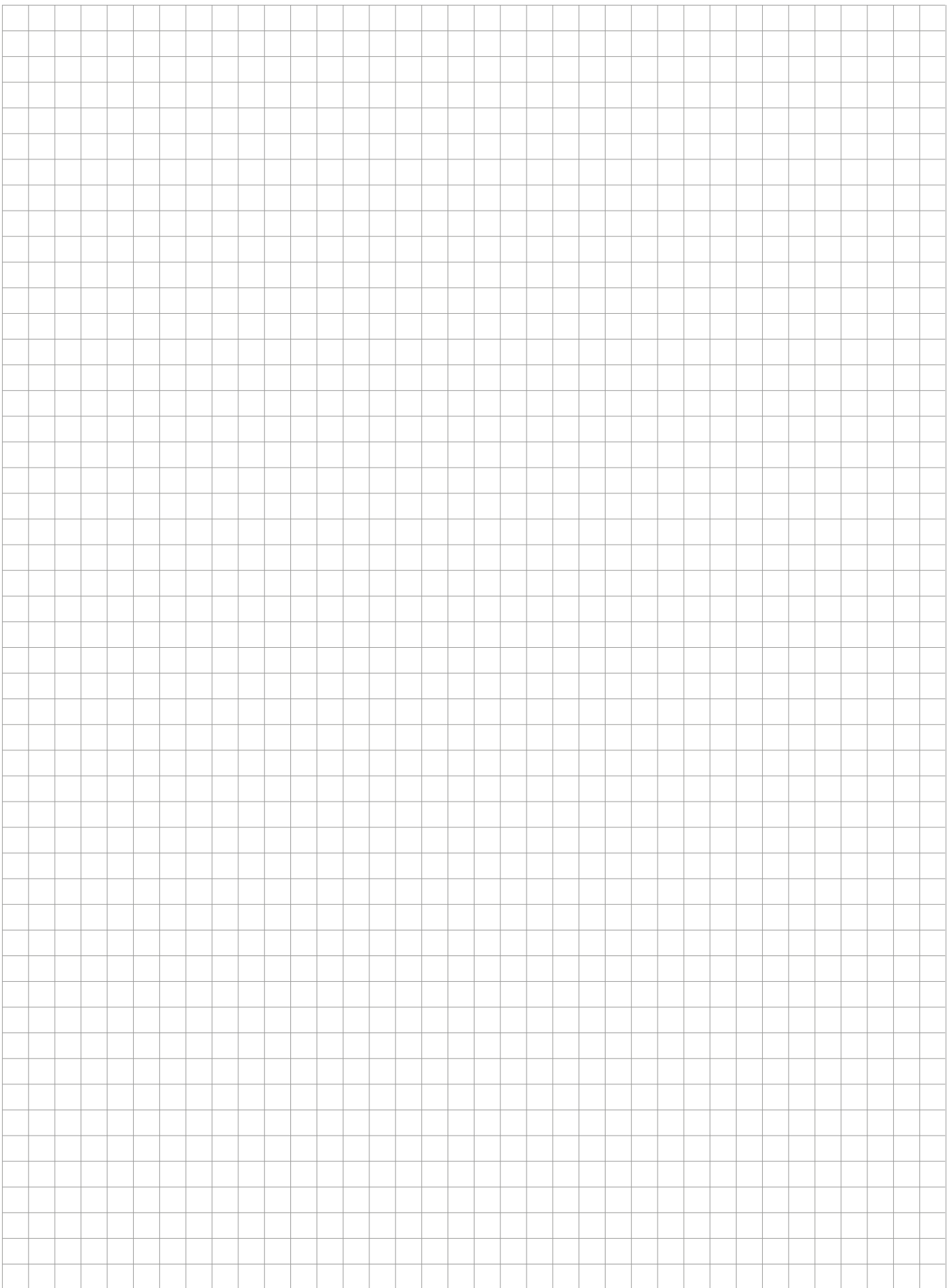

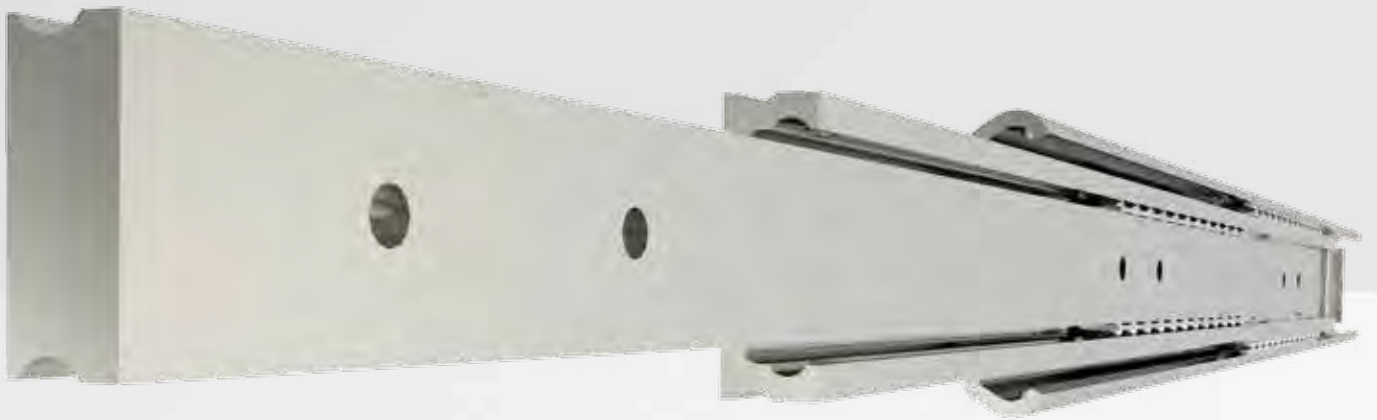

FULL EXTENSIONS

3

PAGE 28

3.1 PRODUCT OVERVIEW

PAGE 32

3.2 FULL EXTENSIONS

- NTV27-26T
- NTV27-28DC
- NTV48-20T
- NTV48-22T
- NTV48-30DC
- NTV59-24T
- NTV59-35DC
- NTV60-26
- NTV72-26T
- NTV72-43DC
- NTV80-27.5
- NTV100-34

PAGE 44

3.3 SPECIAL FULL EXTENSIONS

Z-steel basic profile

- NTVZ45-14
- NTVZ60-17
- NTVZ80-22
- NTVZ100-24
- NTVZ120-28
- NTVZ150-30

PRODUCT OVERVIEW

FULL EXTENSIONS

NTV27-26T

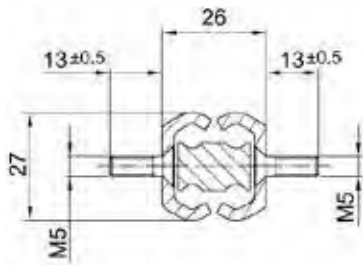

NTV27-28DC

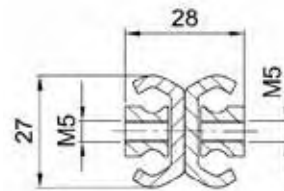

NTV48-20T

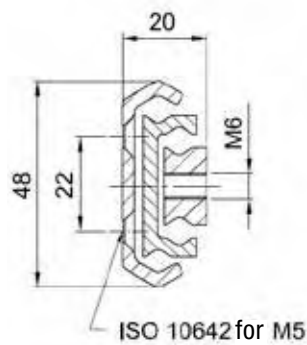

NTV48-22T

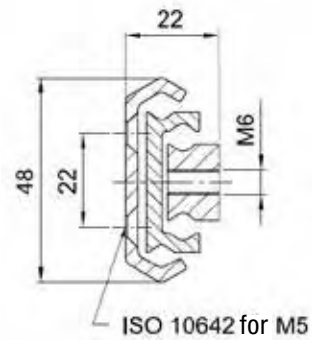

NTV48-30DC

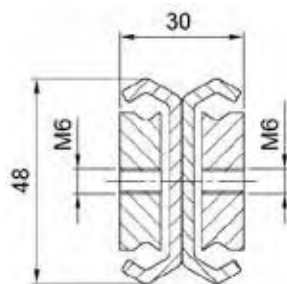

NTV59-24T

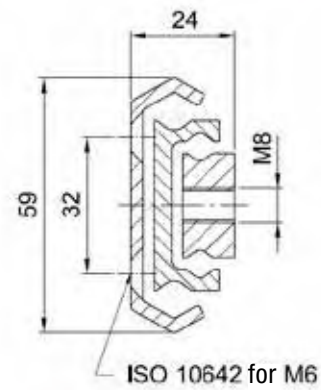

3.1

FULL EXTENSIONS

NTV59-35DC

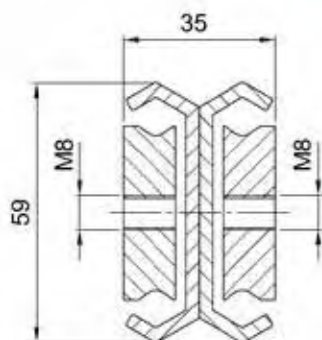

NTV60-26

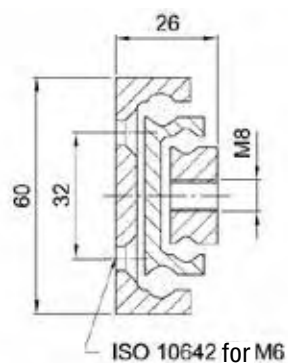

NTV72-26T

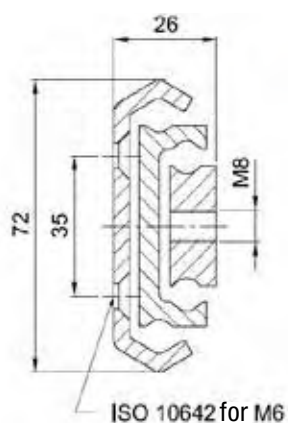

NTV72-43DC

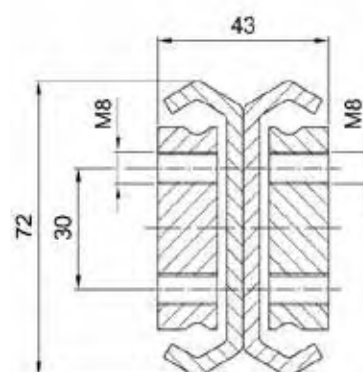

NTV80-27.5

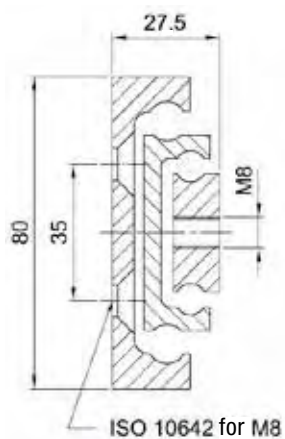

NTV100-34

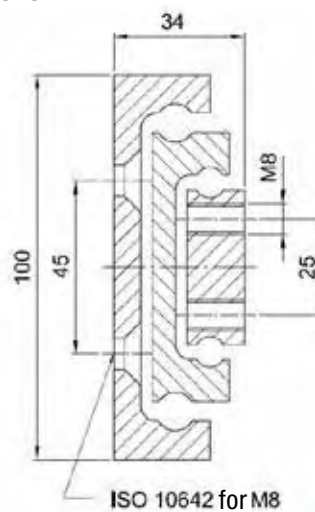

PRODUCT OVERVIEW

FULL EXTENSIONS

NTVZ45-14

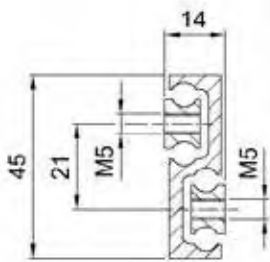

NTVZ60-17

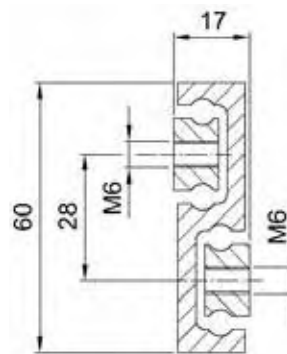

NTVZ80-22

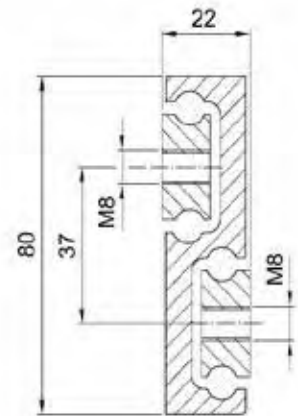

FULL EXTENSIONS

NTVZ100-24

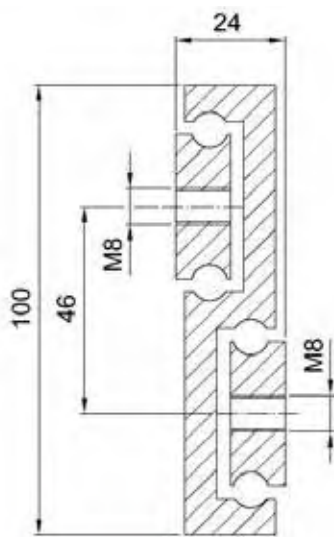

NTVZ120-28

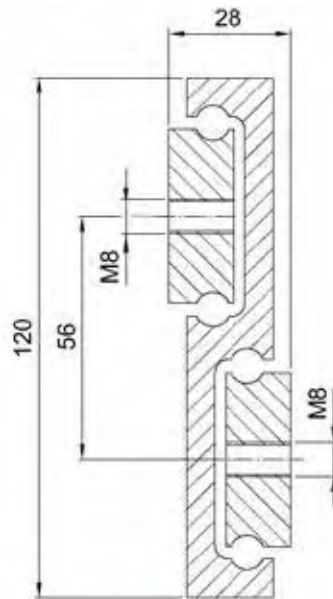

NTVZ150-30

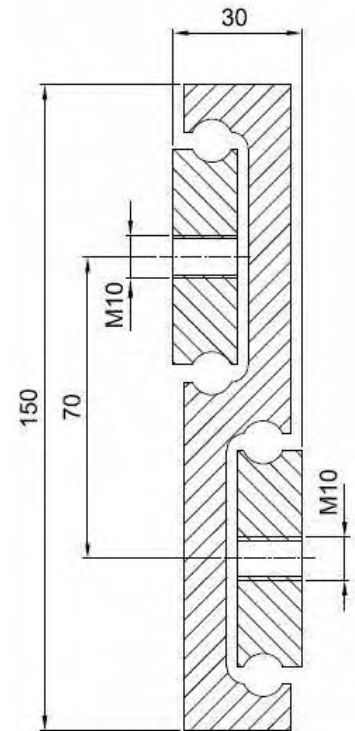

FULL EXTENSION

NTV27-26T

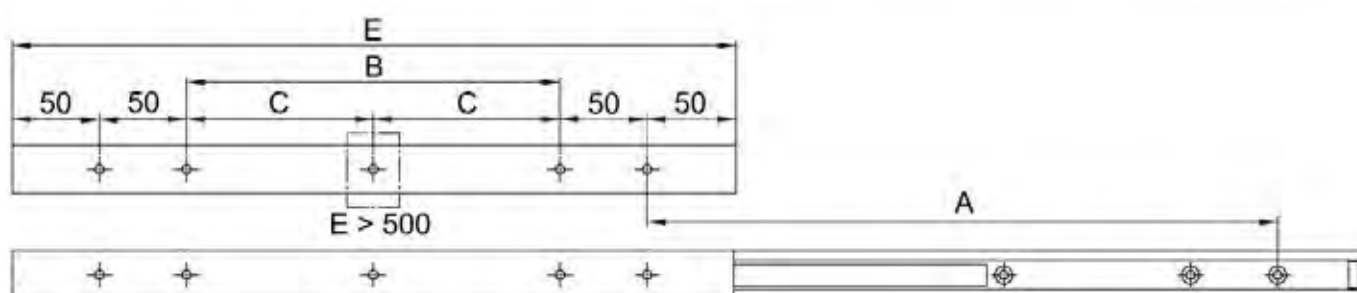
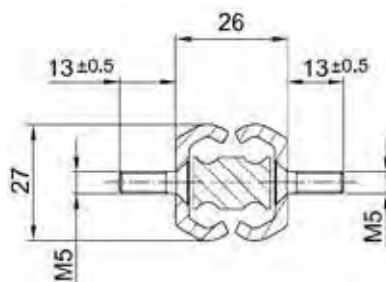

Load Table

Order Number	Hole separation (mm)		Installation length (mm)	Extension length (mm)	Net weight (kg)	Maximum load/pair (N)
	B	C				
NTV27-26T-250	50		250	250	1.0	1100
NTV27-26T-300	100		300	300	1.2	1150
NTV27-26T-350	150		350	350	1.4	1180
NTV27-26T-400	200		400	400	1.6	1200
NTV27-26T-450	250		450	450	1.8	1180
NTV27-26T-500	300		500	500	2.0	1150
NTV27-26T-550		175	550	550	2.2	1120
NTV27-26T-600		200	600	600	2.4	1090
NTV27-26T-650		225	650	650	2.6	1060
NTV27-26T-700		250	700	700	2.8	1030
NTV27-26T-750		275	750	750	3.0	1000
NTV27-26T-800		300	800	800	3.2	970
NTV27-26T-850		325	850	850	3.4	940
NTV27-26T-900		350	900	900	3.6	910
NTV27-26T-950		375	950	950	3.8	880
NTV27-26T-1000		400	1000	1000	4.0	850
NTV27-26T-1100		450	1100	1100	4.4	800
NTV27-26T-1200		500	1200	1200	4.8	750
NTV27-26T-1300		550	1300	1300	5.2	700

Ordercode and further options see last page. Your desired length is not listed in the table? No problem! Only the most common lengths are shown here. Please contact our application technology division.

NTV27-28DC

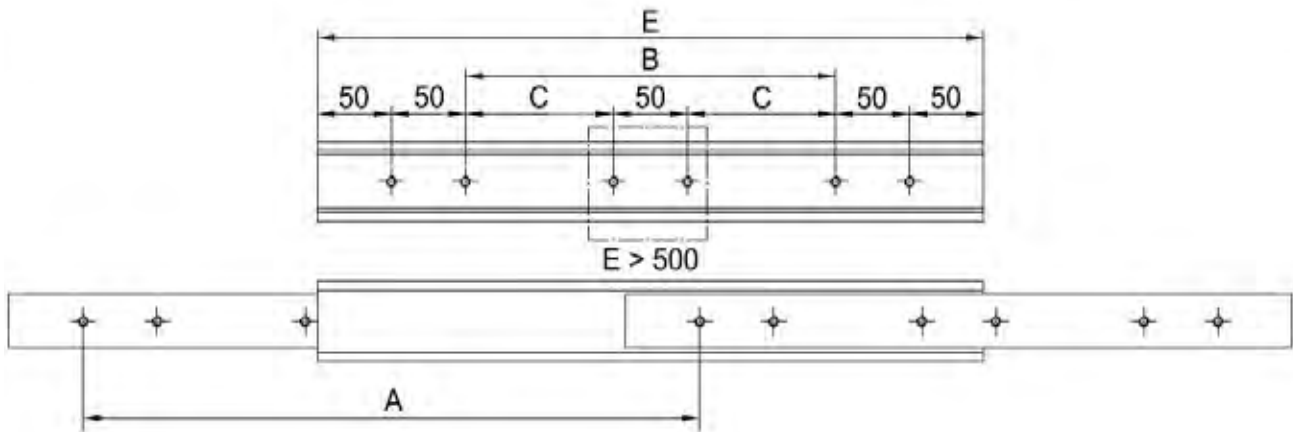
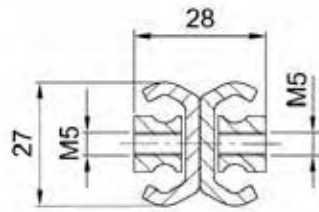

Load Table

Order Number	Hole separation (mm)		Installation length (mm)	Extension length (mm)	Net weight (kg)	Maximum load/pair (N)
	B	C	E	A		
NTV27-28DC-250	50		250	250	0.9	750
NTV27-28DC-300	100		300	300	1.1	800
NTV27-28DC-350	150		350	350	1.3	850
NTV27-28DC-400	200		400	400	1.5	800
NTV27-28DC-450	250		450	450	1.7	750
NTV27-28DC-500	300		500	500	1.9	700
NTV27-28DC-550		150	550	550	2.0	650
NTV27-28DC-600		175	600	600	2.2	600
NTV27-28DC-650		200	650	650	2.4	550
NTV27-28DC-700		225	700	700	2.6	500
NTV27-28DC-750		250	750	750	2.8	450
NTV27-28DC-800		275	800	800	3.0	400
NTV27-28DC-850		300	850	850	3.2	370
NTV27-28DC-900		325	900	900	3.4	340
NTV27-28DC-950		350	950	950	3.6	320
NTV27-28DC-1000		375	1000	1000	3.8	300

Ordercode and further options see last page. Your desired length is not listed in the table? No problem! Only the most common lengths are shown here. Please contact our application technology division.

FULL EXTENSION

NTV48-20T

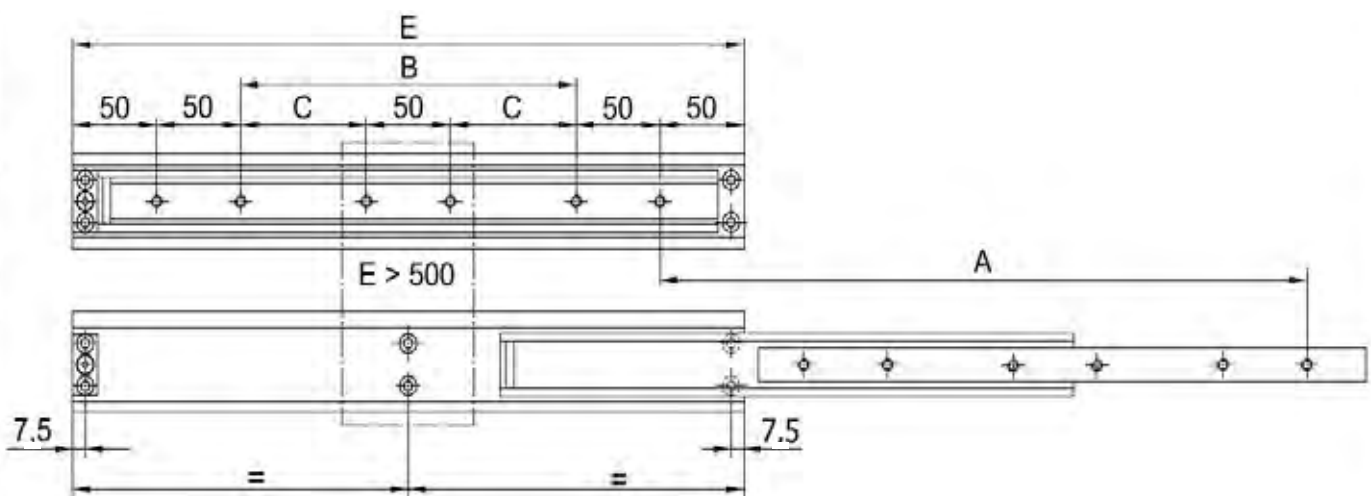
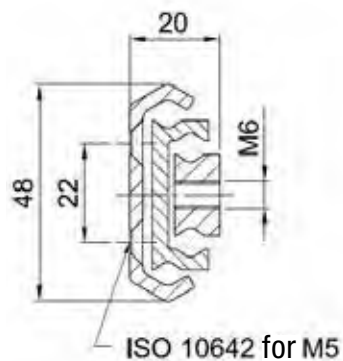

Load Table

Order Number	Hole separation (mm)		Installation length (mm)	Extension length (mm)	Net weight (kg)	Maximum load/pair (N)
	B	C	E	A		
NTV48-20T-300	100		300	300	1.3	1250
NTV48-20T-350	150		350	350	1.5	1300
NTV48-20T-400	200		400	400	1.7	1300
NTV48-20T-450	250		450	450	1.9	1250
NTV48-20T-500	300		500	500	2.1	1250
NTV48-20T-550		150	550	550	2.3	1200
NTV48-20T-600		175	600	600	2.5	1150
NTV48-20T-650		200	650	650	2.7	1100
NTV48-20T-700		225	700	700	2.9	1050
NTV48-20T-750		250	750	750	3.1	1000
NTV48-20T-800		275	800	800	3.3	950
NTV48-20T-850		300	850	850	3.5	900
NTV48-20T-900		325	900	900	3.7	850
NTV48-20T-950		350	950	950	3.9	800
NTV48-20T-1000		375	1000	1000	4.1	750
NTV48-20T-1100		425	1100	1100	4.9	650
NTV48-20T-1200		475	1200	1200	5.0	550

Ordercode and further options see last page. Your desired length is not listed in the table? No problem! Only the most common lengths are shown here. Please contact our application technology division.

NTV48-22T

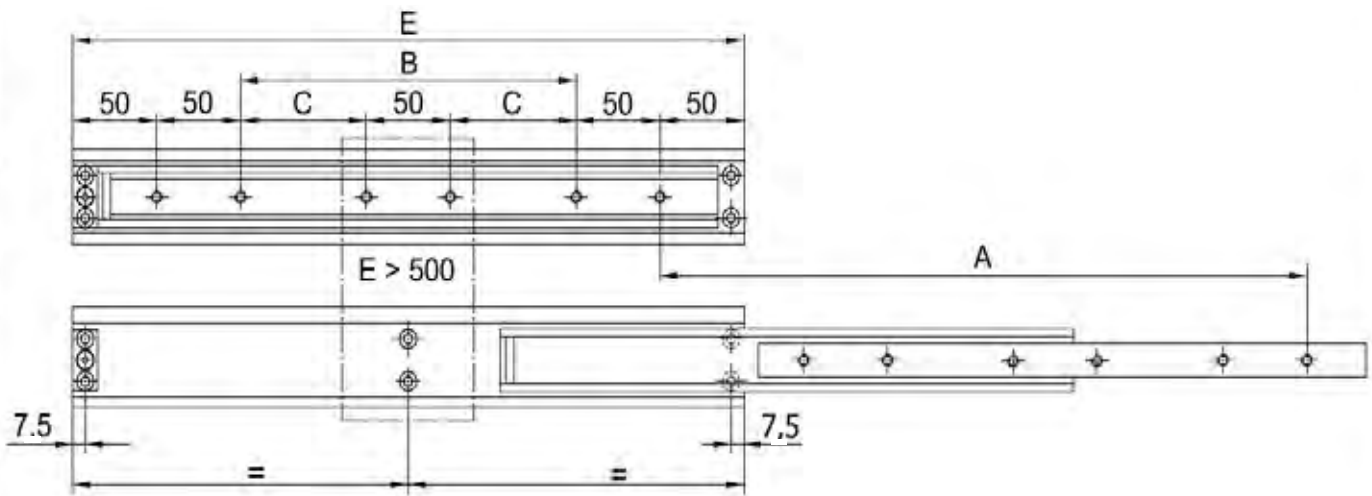
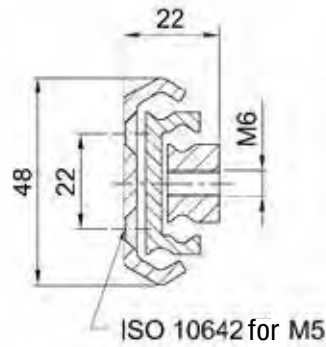

Load Table

Order Number	Hole separation (mm)		Installation length (mm)	Extension length (mm)	Net weight (kg)	Maximum load/pair (N)
	B	C	E	A		
NTV48-22T-300	100		300	300	1.4	1410
NTV48-22T-350	150		350	350	1.6	1460
NTV48-22T-400	200		400	400	1.9	1510
NTV48-22T-450	250		450	450	2.1	1460
NTV48-22T-500	300		500	500	2.4	1410
NTV48-22T-550		150	550	550	2.6	1360
NTV48-22T-600		175	600	600	2.9	1310
NTV48-22T-650		200	650	650	3.1	1260
NTV48-22T-700		225	700	700	3.4	1210
NTV48-22T-750		250	750	750	3.6	1160
NTV48-22T-800		275	800	800	3.9	1110
NTV48-22T-850		300	850	850	4.1	1060
NTV48-22T-900		325	900	900	4.4	1010
NTV48-22T-950		350	950	950	4.6	960
NTV48-22T-1000		375	1000	1000	4.9	910
NTV48-22T-1100		425	1100	1100	5.4	810
NTV48-22T-1200		475	1200	1200	5.9	710
NTV48-22T-1300		525	1300	1300	6.4	610
NTV48-22T-1400		575	1400	1400	6.9	510
NTV48-22T-1500		625	1500	1500	7.4	410

Ordercode and further options see last page. Your desired length is not listed in the table? No problem! Only the most common lengths are shown here. Please contact our application technology division.

FULL EXTENSION

NTV48-30DC

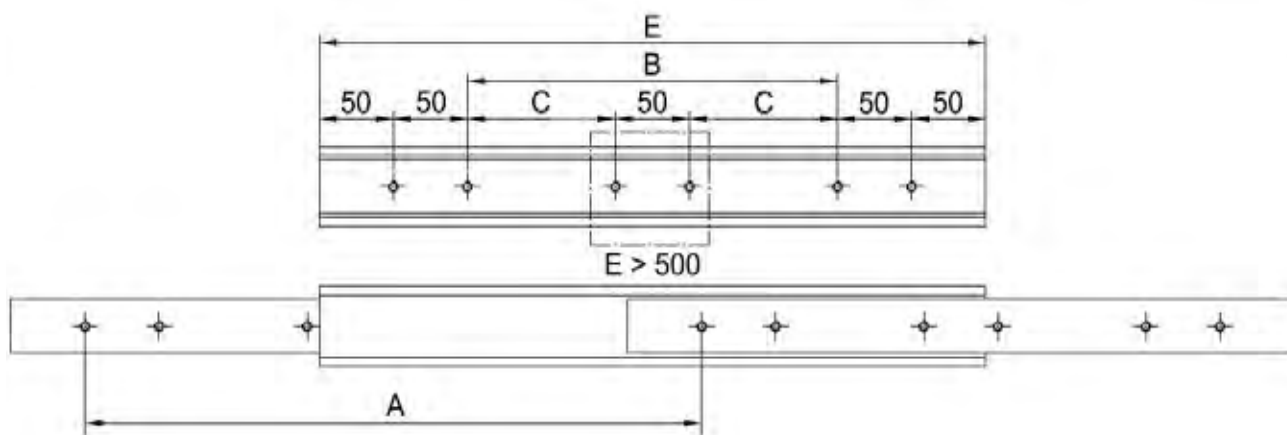
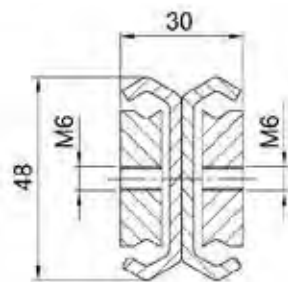

Load Table

Order Number	Hole separation (mm)		Installation length (mm)	Extension length (mm)	Net weight (kg)	Maximum load/pair (N)
	B	C	E	A		
NTV48-30DC-300	100		300	300	2.6	1810
NTV48-30DC-350	150		350	350	3.0	1860
NTV48-30DC-400	200		400	400	3.4	1910
NTV48-30DC-450	250		450	450	3.9	1860
NTV48-30DC-500	300		500	500	4.3	1810
NTV48-30DC-550		150	550	550	4.8	1760
NTV48-30DC-600		175	600	600	5.2	1710
NTV48-30DC-650		200	650	650	5.6	1660
NTV48-30DC-700		225	700	700	6.1	1610
NTV48-30DC-750		250	750	750	6.5	1560
NTV48-30DC-800		275	800	800	7.0	1510
NTV48-30DC-850		300	850	850	7.4	1460
NTV48-30DC-900		325	900	900	7.9	1410
NTV48-30DC-950		350	950	950	8.3	1360
NTV48-30DC-1000		375	1000	1000	8.7	1310
NTV48-30DC-1100		425	1100	1100	9.6	1210
NTV48-30DC-1200		475	1200	1200	10.5	1110
NTV48-30DC-1300		525	1300	1300	11.4	1010
NTV48-30DC-1400		575	1400	1400	12.3	910
NTV48-30DC-1500		625	1500	1500	13.2	810

Ordercode and further options see last page. Your desired length is not listed in the table? No problem! Only the most common lengths are shown here. Please contact our application technology division.

NTV59-24T

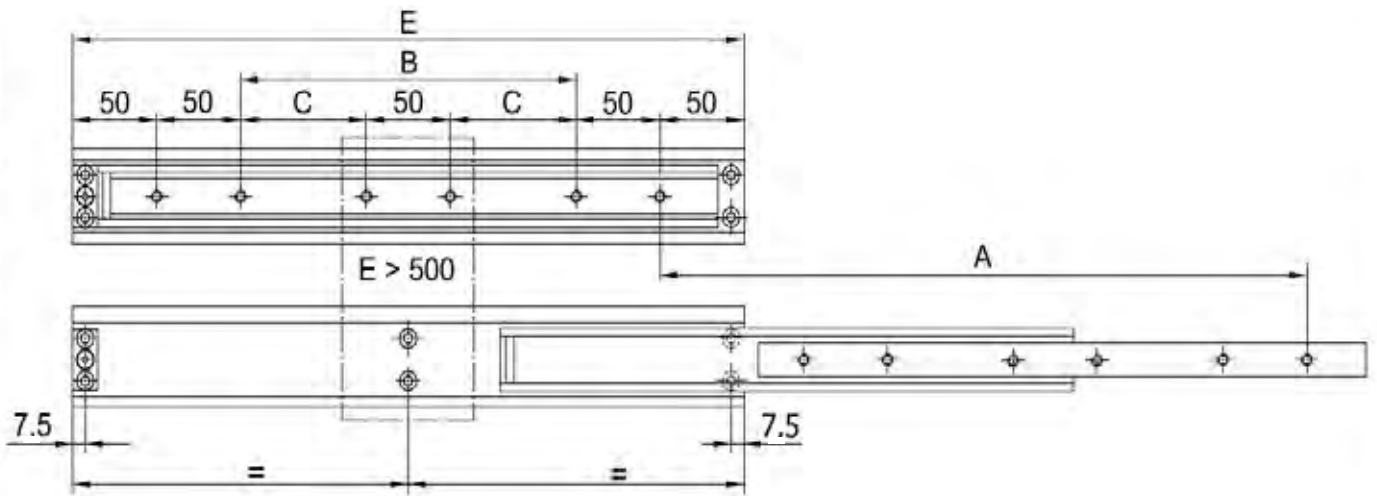
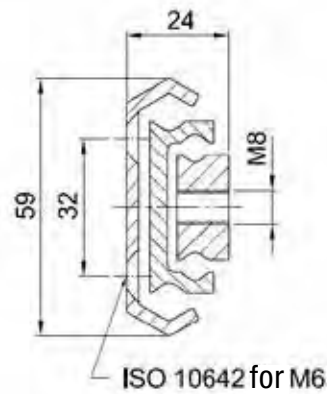

Load Table

Order Number	Hole separation (mm)		Installation length (mm)	Extension length (mm)	Net weight (kg)	Maximum load/pair (N)
	B	C	E	A		
NTV59-24T-300	100		300	300	1.8	2100
NTV59-24T-350	150		350	350	2.4	2150
NTV59-24T-400	200		400	400	2.5	2200
NTV59-24T-450	250		450	450	2.8	2150
NTV59-24T-500	300		500	500	3.1	2100
NTV59-24T-550		150	550	550	3.4	2050
NTV59-24T-600		175	600	600	3.8	2000
NTV59-24T-650		200	650	650	4.1	1950
NTV59-24T-700		225	700	700	4.4	1900
NTV59-24T-750		250	750	750	4.7	1850
NTV59-24T-800		275	800	800	5.1	1800
NTV59-24T-850		300	850	850	5.4	1750
NTV59-24T-900		325	900	900	5.7	1700
NTV59-24T-950		350	950	950	6.0	1650
NTV59-24T-1000		375	1000	1000	6.4	1600
NTV59-24T-1100		425	1100	1100	7.0	1500
NTV59-24T-1200		475	1200	1200	7.6	1400
NTV59-24T-1300		525	1300	1300	8.4	1300
NTV59-24T-1400		575	1400	1400	9.1	1200
NTV59-24T-1500		625	1500	1500	9.5	1100

Ordercode and further options see last page. Your desired length is not listed in the table? No problem! Only the most common lengths are shown here. Please contact our application technology division.

FULL EXTENSION

NTV59-35DC

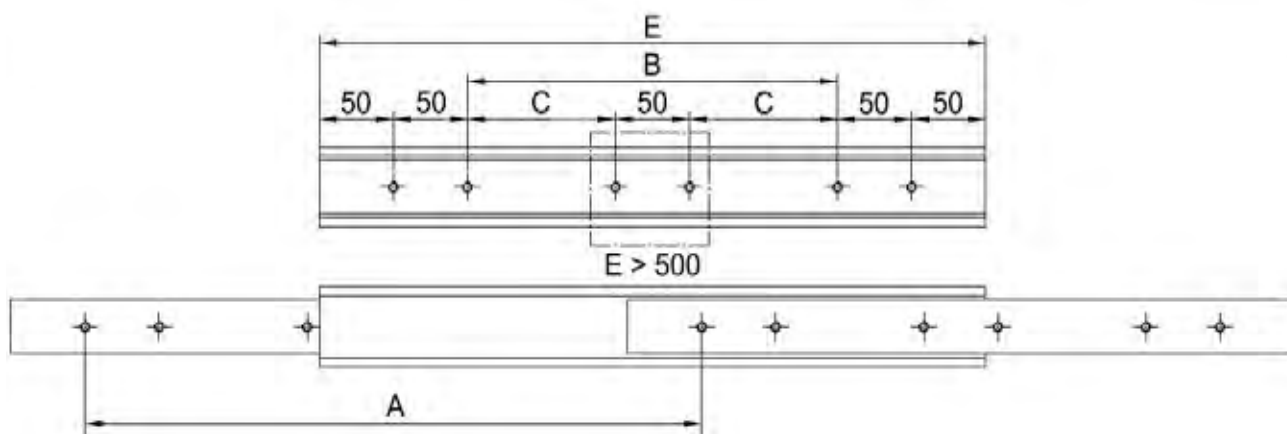
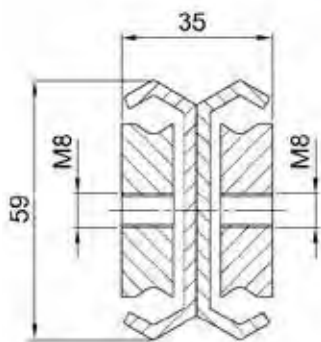

Load Table

Order Number	Hole separation (mm)		Installation length (mm)	Extension length (mm)	Net weight (kg)	Maximum load/pair (N)
	B	C				
NTV59-35DC-300	100		300	300	3.5	2600
NTV59-35DC-350	150		350	350	4.1	2650
NTV59-35DC-400	200		400	400	4.7	2700
NTV59-35DC-450	250		450	450	5.3	2650
NTV59-35DC-500	300		500	500	5.8	2600
NTV59-35DC-550		150	550	550	6.4	2550
NTV59-35DC-600		175	600	600	7.0	2500
NTV59-35DC-650		200	650	650	7.6	2450
NTV59-35DC-700		225	700	700	8.2	2400
NTV59-35DC-750		250	750	750	8.8	2350
NTV59-35DC-800		275	800	800	9.4	2300
NTV59-35DC-850		300	850	850	10.0	2250
NTV59-35DC-900		325	900	900	10.5	2200
NTV59-35DC-950		350	950	950	11.1	2100
NTV59-35DC-1000		375	1000	1000	11.7	2050
NTV59-35DC-1100		425	1100	1100	12.9	1950
NTV59-35DC-1200		475	1200	1200	14.0	1850
NTV59-35DC-1300		525	1300	1300	15.2	1750
NTV59-35DC-1400		575	1400	1400	16.4	1650
NTV59-35DC-1500		625	1500	1500	17.6	1600

Ordercode and further options see last page. Your desired length is not listed in the table? No problem! Only the most common lengths are shown here. Please contact our application technology division.

3.2

NTV60-26

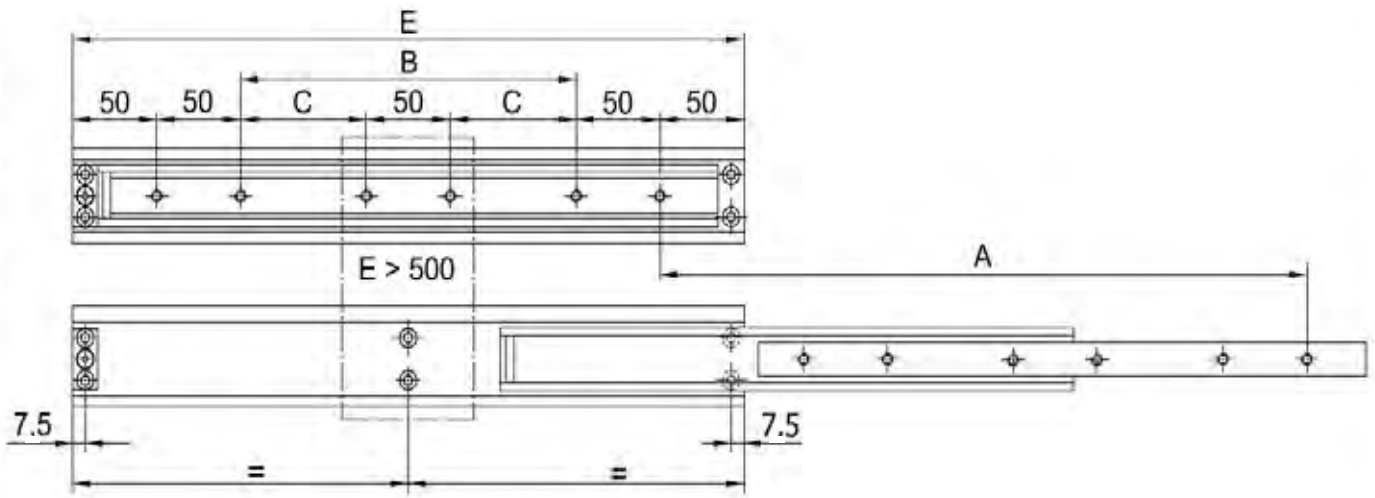
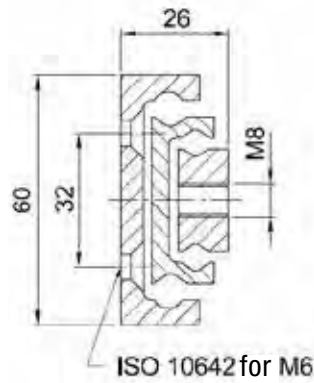

Load Table

Order Number	Hole separation (mm)		Installation length (mm)	Extension length (mm)	Net weight (kg)	Maximum load/pair (N)
	B	C	E	A		
NTV60-26-300	100		300	300	1.5	2800
NTV60-26-350	150		350	350	1.8	2850
NTV60-26-400	200		400	400	2.0	2900
NTV60-26-450	250		450	450	2.3	2850
NTV60-26-500	300		500	500	2.5	2800
NTV60-26-550		150	550	550	2.8	2800
NTV60-26-600		175	600	600	3.0	2700
NTV60-26-650		200	650	650	3.3	2650
NTV60-26-700		225	700	700	3.5	2600
NTV60-26-750		250	750	750	3.8	2550
NTV60-26-800		275	800	800	4.0	2500
NTV60-26-850		300	850	850	4.3	2450
NTV60-26-900		325	900	900	4.5	2400
NTV60-26-950		350	950	950	4.8	2330
NTV60-26-1000		375	1000	1000	5.1	2250
NTV60-26-1100		425	1100	1100	5.6	2100
NTV60-26-1200		475	1200	1200	6.1	1950
NTV60-26-1300		525	1300	1300	6.6	1800
NTV60-26-1400		575	1400	1400	7.1	1700
NTV60-26-1500		625	1500	1500	7.6	1600

Ordercode and further options see last page. Your desired length is not listed in the table? No problem! Only the most common lengths are shown here. Please contact our application technology division.

FULL EXTENSION

NTV72-26T

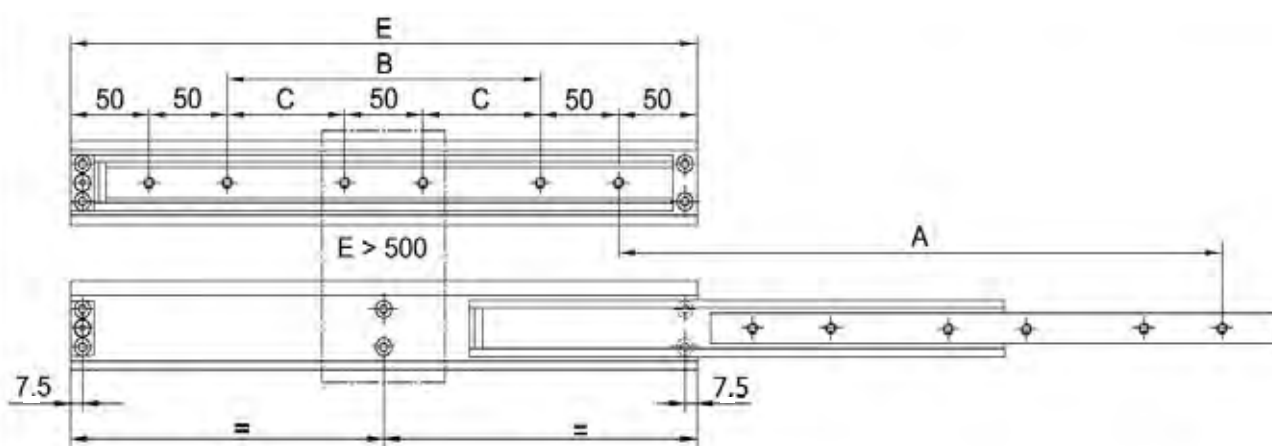
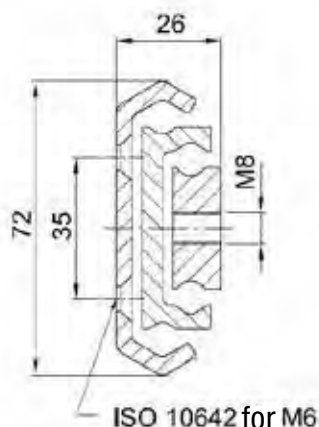

Load Table

Order Number	Hole separation (mm)		Installation length (mm)	Extension length (mm)	Net weight (kg)	Maximum load/pair (N)
	B	C	E	A		
NTV72-26T-300	100		300	300	2.5	3300
NTV72-26T-350	150		350	350	3.0	3350
NTV72-26T-400	200		400	400	3.5	3400
NTV72-26T-450	250		450	450	4.0	3350
NTV72-26T-500	300		500	500	4.4	3300
NTV72-26T-550		150	550	550	4.9	3250
NTV72-26T-600		175	600	600	5.4	3100
NTV72-26T-650		200	650	650	5.9	3150
NTV72-26T-700		225	700	700	6.3	3100
NTV72-26T-750		250	750	750	6.8	3050
NTV72-26T-800		275	800	800	7.3	3000
NTV72-26T-850		300	850	850	7.7	2950
NTV72-26T-900		325	900	900	8.2	2900
NTV72-26T-950		350	950	950	8.6	2850
NTV72-26T-1000		375	1000	1000	9.1	2800
NTV72-26T-1100		425	1100	1100	10.0	2700
NTV72-26T-1200		475	1200	1200	10.9	2600
NTV72-26T-1300		525	1300	1300	11.9	2450
NTV72-26T-1400		575	1400	1400	12.9	2300
NTV72-26T-1500		625	1500	1500	13.9	2150
NTV72-26T-1600		675	1600	1600	14.7	2000
NTV72-26T-1700		725	1700	1700	15.6	1850
NTV72-26T-1800		775	1800	1800	16.5	1700
NTV72-26T-1900		825	1900	1900	17.5	1550
NTV72-26T-2000		875	2000	2000	18.4	1400

Ordercode and further options see last page. Your desired length is not listed in the table? No problem! Only the most common lengths are shown here. Please contact our application technology division.

NTV72-43DC

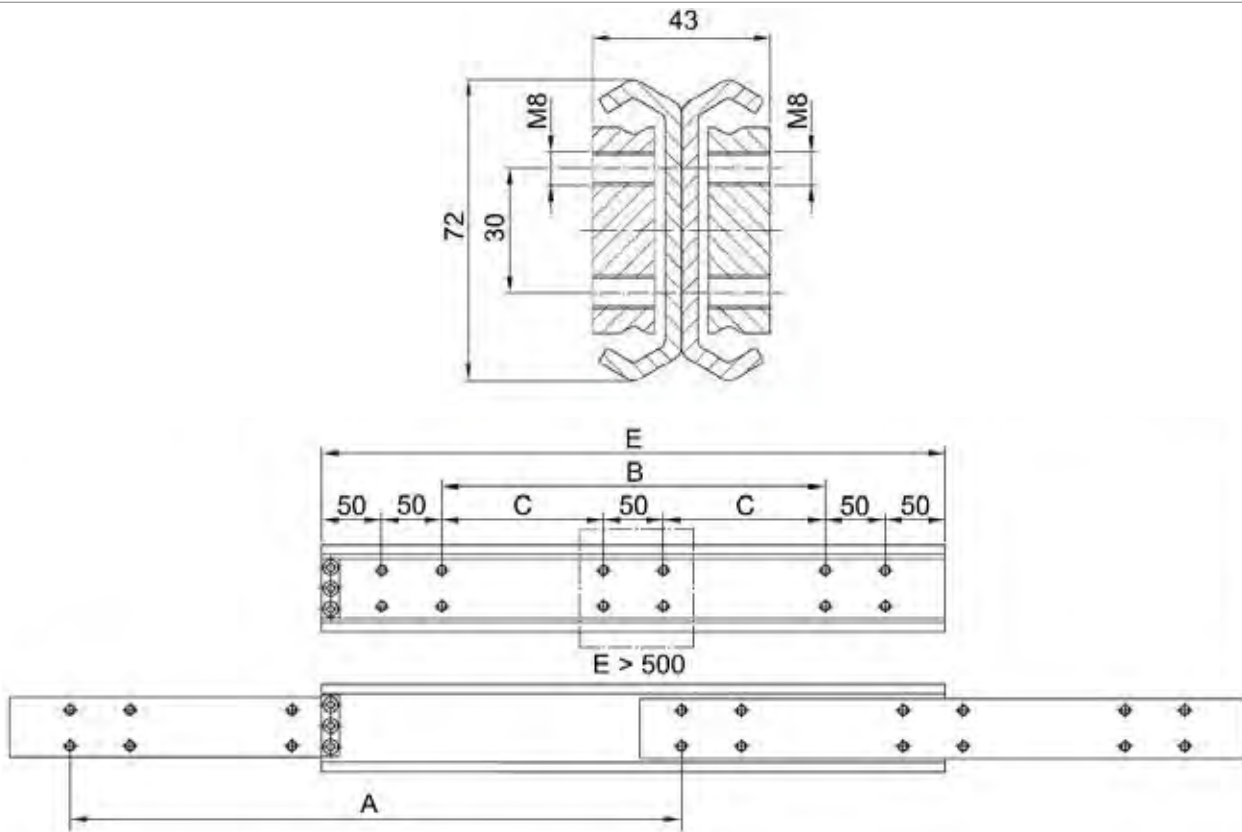

Load Table

Order Number	Hole separation (mm)		Installation length (mm)	Extension length (mm)	Net weight (kg)	Maximum load/pair (N)
	B	C	E	A		
NTV72-43DC-300	100		300	300	5.4	3800
NTV72-43DC-350	150		350	350	6.4	3850
NTV72-43DC-400	200		400	400	7.3	3900
NTV72-43DC-450	250		450	450	8.2	3850
NTV72-43DC-500	300		500	500	9.2	3800
NTV72-43DC-550		150	550	550	10.1	3750
NTV72-43DC-600		175	600	600	11.1	3700
NTV72-43DC-650		200	650	650	12.0	3650
NTV72-43DC-700		225	700	700	13.0	3600
NTV72-43DC-750		250	750	750	13.9	3550
NTV72-43DC-800		275	800	800	14.8	3500
NTV72-43DC-850		300	850	850	15.8	3450
NTV72-43DC-900		325	900	900	16.7	3400
NTV72-43DC-950		350	950	950	17.7	3350
NTV72-43DC-1000		375	1000	1000	18.6	3300
NTV72-43DC-1100		425	1100	1100	19.5	3200
NTV72-43DC-1200		475	1200	1200	22.4	3100
NTV72-43DC-1300		525	1300	1300	24.2	2950
NTV72-43DC-1400		575	1400	1400	26.1	2800
NTV72-43DC-1500		625	1500	1500	28.0	2650
NTV72-43DC-1600		675	1600	1600	29.9	2500
NTV72-43DC-1700		725	1700	1700	31.8	2300
NTV72-43DC-1800		775	1800	1800	33.6	2100
NTV72-43DC-1900		825	1900	1900	35.5	1900
NTV72-43DC-2000		875	2000	2000	37.4	1600

Ordercode and further options see last page. Your desired length is not listed in the table? No problem! Only the most common lengths are shown here. Please contact our application technology division.

FULL EXTENSION

NTV80-27.5

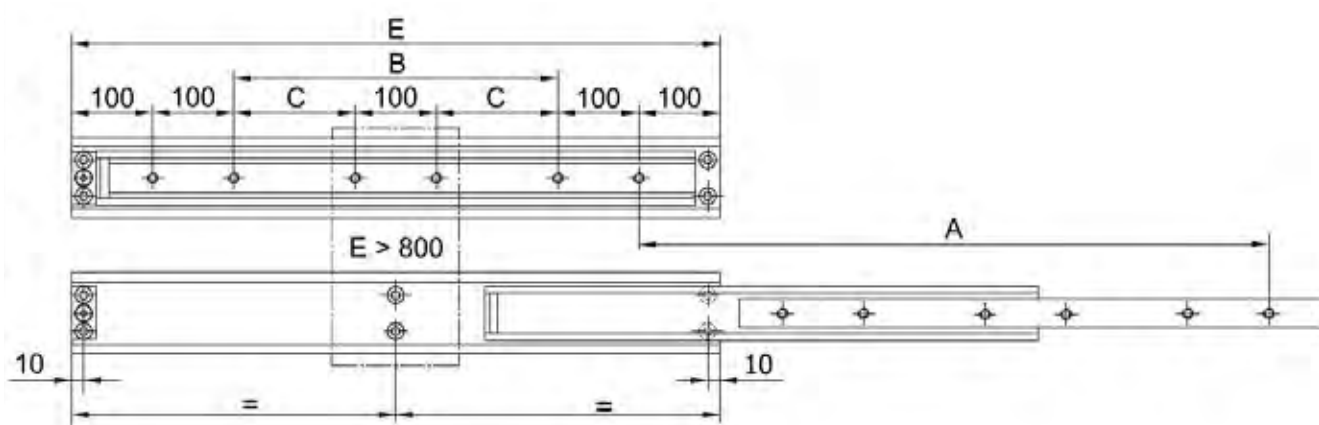
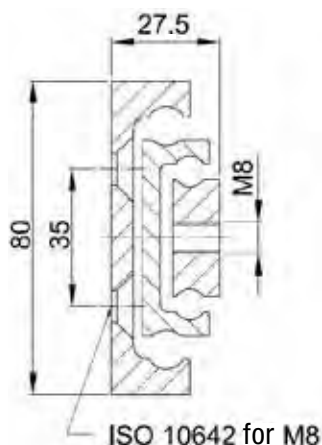

Load Table

Order Number	Hole separation (mm)		Installation length (mm)	Extension length (mm)	Net weight (kg)	Maximum load/pair (N)
	B	C	E	A		
NTV80-27.5-500	100		500	500	5.7	4350
NTV80-27.5-550	150		550	550	6.3	4400
NTV80-27.5-600	200		600	600	6.8	4450
NTV80-27.5-650	250		650	650	7.4	4450
NTV80-27.5-700	300		700	700	8.0	4450
NTV80-27.5-750	350		750	750	8.6	4400
NTV80-27.5-800	400		800	800	9.1	4350
NTV80-27.5-850		175	850	850	9.7	4300
NTV80-27.5-900		200	900	900	10.3	4200
NTV80-27.5-950		225	950	950	10.8	4100
NTV80-27.5-1000		250	1000	1000	11.4	4000
NTV80-27.5-1100		300	1100	1100	12.5	3800
NTV80-27.5-1200		350	1200	1200	13.7	3600
NTV80-27.5-1300		400	1300	1300	14.8	3350
NTV80-27.5-1400		450	1400	1400	15.9	3100
NTV80-27.5-1500		500	1500	1500	17.1	2800
NTV80-27.5-1600		550	1600	1600	18.2	2500
NTV80-27.5-1700		600	1700	1700	19.4	2250
NTV80-27.5-1800		650	1800	1800	20.5	2000
NTV80-27.5-1900		700	1900	1900	21.6	1750
NTV80-27.5-2000		750	2000	2000	22.8	1500

Ordercode and further options see last page. Your desired length is not listed in the table? No problem! Only the most common lengths are shown here. Please contact our application technology division.

NTV100-34

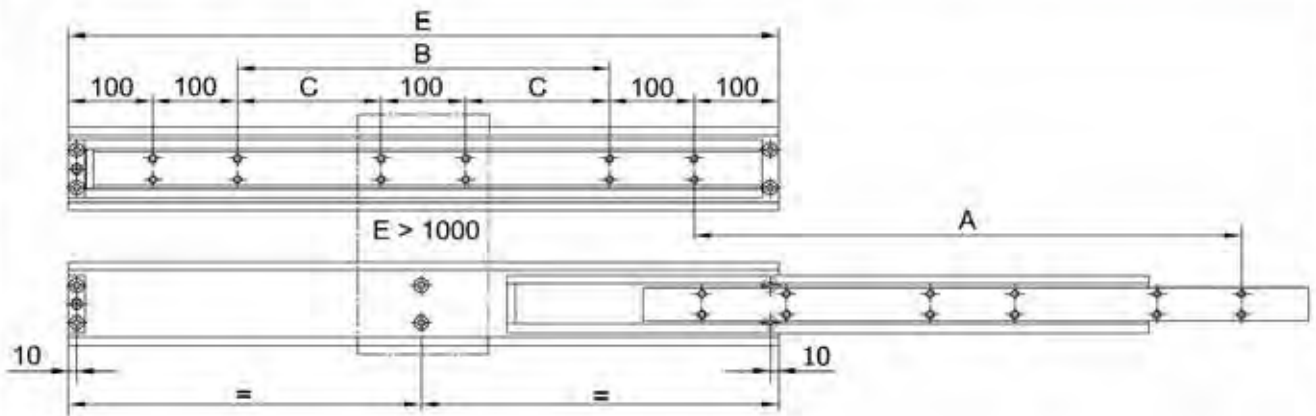
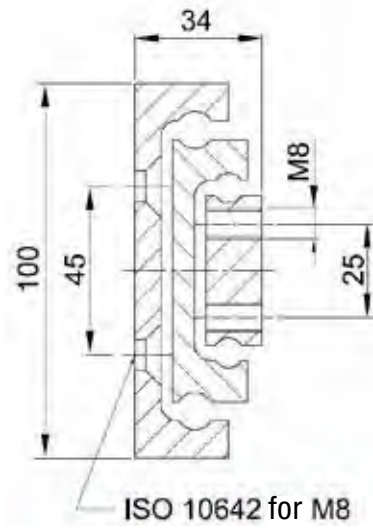

Load Table

Order Number	Hole separation (mm)		Installation length (mm)	Extension length (mm)	Net weight (kg)	Maximum load/pair (N)
	B	C	E	A		
NTV100-34-600	200		600	600	11.2	5750
NTV100-34-650	250		650	650	12.2	5650
NTV100-34-700	300		700	700	13.1	5550
NTV100-34-750	350		750	750	14.0	5450
NTV100-34-800	400		800	800	15.0	5350
NTV100-34-850	450		850	850	15.9	5250
NTV100-34-900	500		900	900	16.8	5150
NTV100-34-950	550		950	950	17.8	5050
NTV100-34-1000	600		1000	1000	18.7	4950
NTV100-34-1100		300	1100	1100	20.6	4750
NTV100-34-1200		350	1200	1200	22.5	4550
NTV100-34-1300		400	1300	1300	24.3	4300
NTV100-34-1400		450	1400	1400	26.2	4050
NTV100-34-1500		500	1500	1500	28.1	3800
NTV100-34-1600		550	1600	1600	29.9	3550
NTV100-34-1700		600	1700	1700	31.8	3300
NTV100-34-1800		650	1800	1800	33.7	3050
NTV100-34-1900		700	1900	1900	35.6	2750
NTV100-34-2000		750	2000	2000	37.4	2450

Ordercode and further options see last page. Your desired length is not listed in the table? No problem! Only the most common lengths are shown here. Please contact our application technology division.

FULL EXTENSION

NTVZ45-14

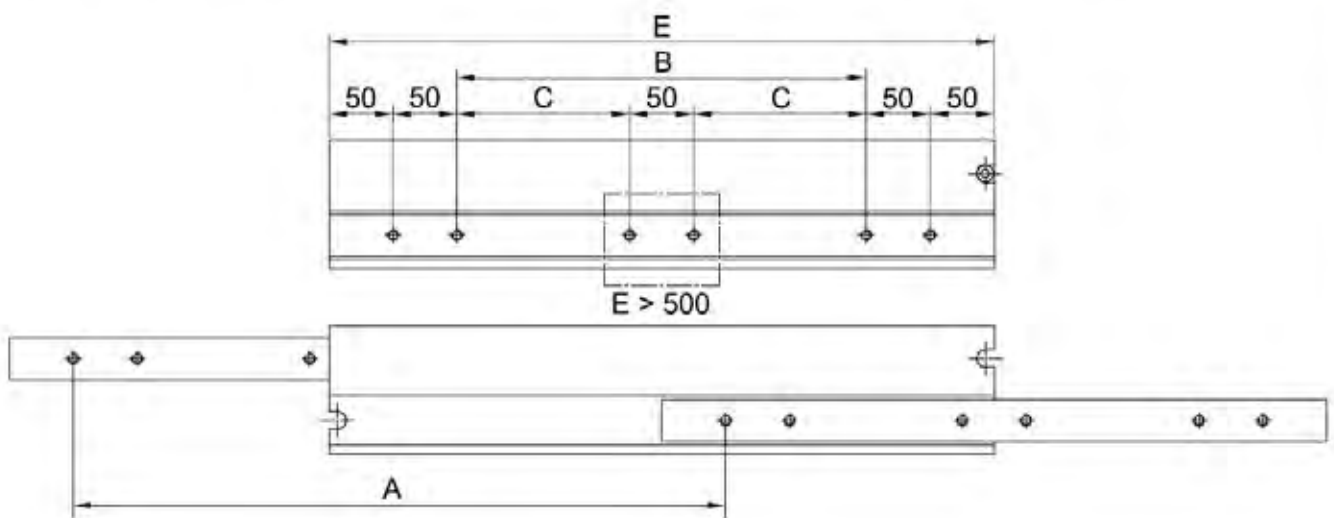
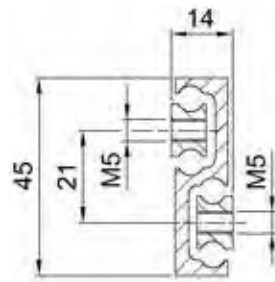

Order Number	Load Table					
	Hole separation (mm)		Installation length (mm)	Extension length (mm)	Net weight (kg)	Maximum load/pair (N)
	B	C	E	A		
NTVZ45-14-250	50		250	250	0.8	450
NTVZ45-14-300	100		300	300	0.9	530
NTVZ45-14-350	150		350	350	1.1	650
NTVZ45-14-400	200		400	400	1.2	600
NTVZ45-14-450	250		450	450	1.4	550
NTVZ45-14-500	300		500	500	1.6	500
NTVZ45-14-550		150	550	550	1.7	450
NTVZ45-14-600		175	600	600	1.9	400
NTVZ45-14-650		200	650	650	2.0	360
NTVZ45-14-700		225	700	700	2.2	330
NTVZ45-14-750		250	750	750	2.3	300
NTVZ45-14-800		275	800	800	2.5	250

Ordercode and further options see last page. Your desired length is not listed in the table? No problem! Only the most common lengths are shown here. Please contact our application technology division.

NTVZ60-17

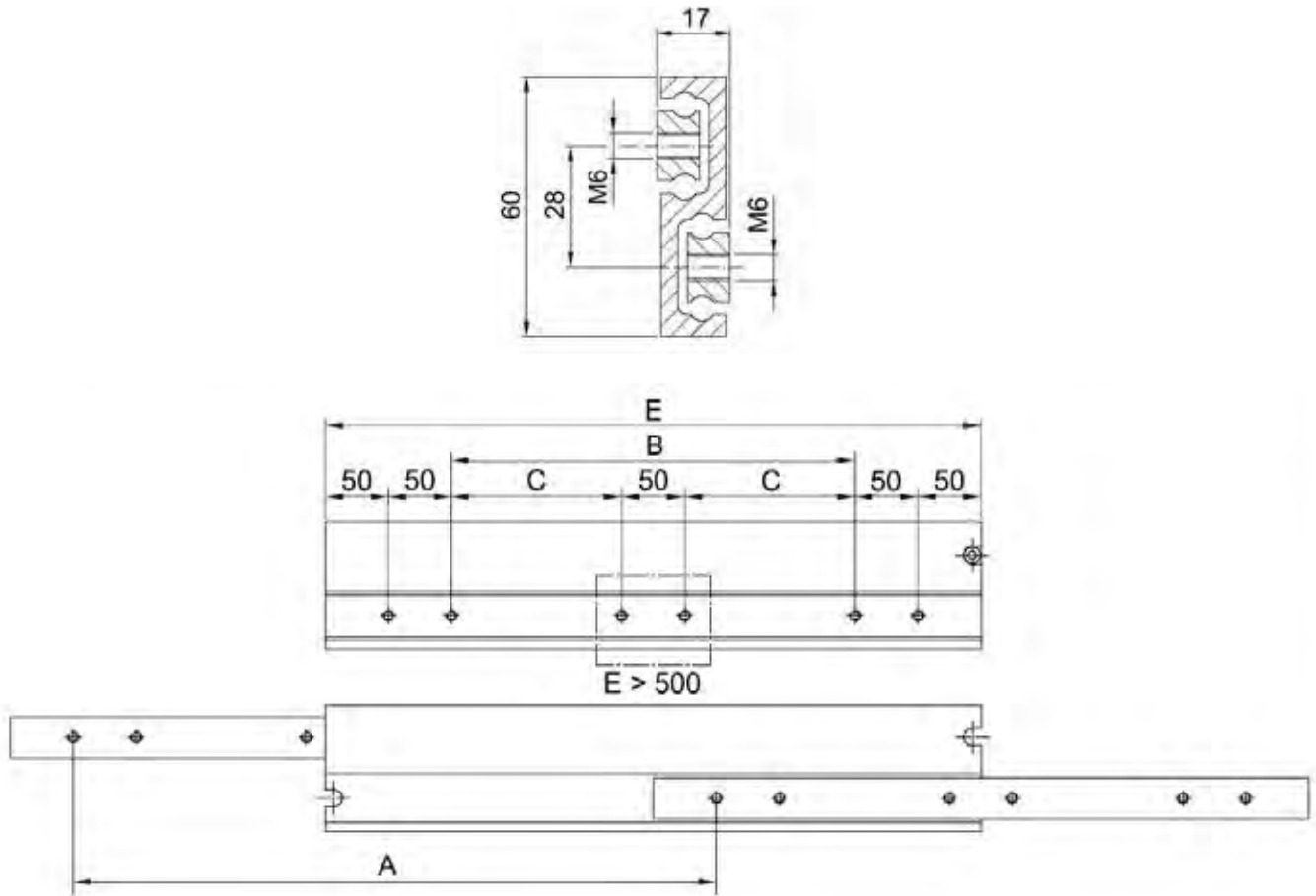

Load Table

Order Number	Hole separation (mm)		Installation length (mm)	Extension length (mm)	Net weight (kg)	Maximum load/pair (N)
	B	C	E	A		
NTVZ60-17-250	50		250	250	1.8	1000
NTVZ60-17-300	100		300	300	2.0	1250
NTVZ60-17-350	150		350	350	2.2	1350
NTVZ60-17-400	200		400	400	2.5	1400
NTVZ60-17-450	250		450	450	2.8	1400
NTVZ60-17-500	300		500	500	3.1	1400
NTVZ60-17-550		150	550	550	3.5	1350
NTVZ60-17-600		175	600	600	3.7	1300
NTVZ60-17-650		200	650	650	4.1	1250
NTVZ60-17-700		225	700	700	4.1	1200
NTVZ60-17-750		250	750	750	4.4	1150
NTVZ60-17-800		275	800	800	4.7	1050
NTVZ60-17-850		300	850	850	5.0	950
NTVZ60-17-900		325	900	900	5.3	850
NTVZ60-17-950		350	950	950	5.7	750
NTVZ60-17-1000		375	1000	1000	6.0	650

Ordercode and further options see last page. Your desired length is not listed in the table? No problem! Only the most common lengths are shown here. Please contact our application technology division.

FULL EXTENSION

NTVZ80-22

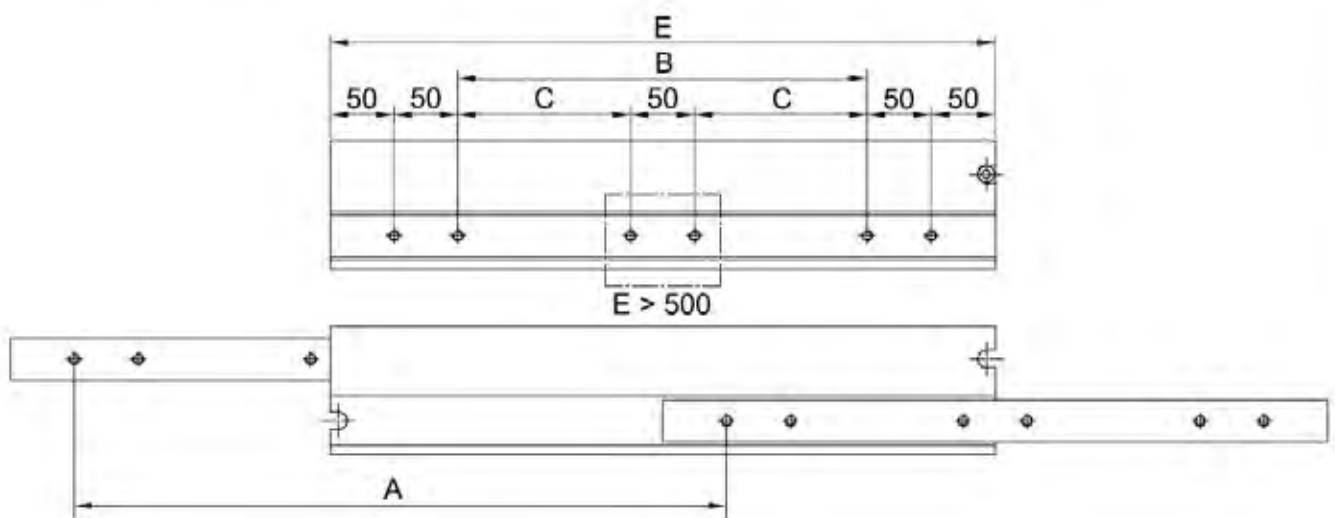
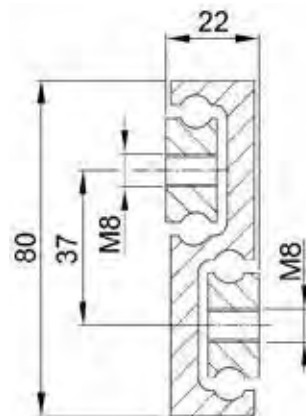

Load Table

Order Number	Hole separation (mm)		Installation length (mm)	Extension length (mm)	Net weight (kg)	Maximum load/pair (N)
	B	C	E	A		
NTVZ80-22-250	50		250	250	2.7	1600
NTVZ80-22-300	100		300	300	3.2	2000
NTVZ80-22-350	150		350	350	3.7	2200
NTVZ80-22-400	200		400	400	4.2	2350
NTVZ80-22-450	250		450	450	4.7	2450
NTVZ80-22-500	300		500	500	5.3	2450
NTVZ80-22-550		150	550	550	5.8	2450
NTVZ80-22-600		175	600	600	6.3	2400
NTVZ80-22-650		200	650	650	6.8	2300
NTVZ80-22-700		225	700	700	7.4	2200
NTVZ80-22-750		250	750	750	7.9	2100
NTVZ80-22-800		275	800	800	8.4	2000
NTVZ80-22-850		300	850	850	8.9	1900
NTVZ80-22-900		325	900	900	9.4	1800
NTVZ80-22-950		350	950	950	10.0	1650
NTVZ80-22-1000		375	1000	1000	10.5	1500

Ordercode and further options see last page. Your desired length is not listed in the table? No problem! Only the most common lengths are shown here. Please contact our application technology division.

NTVZ100-24

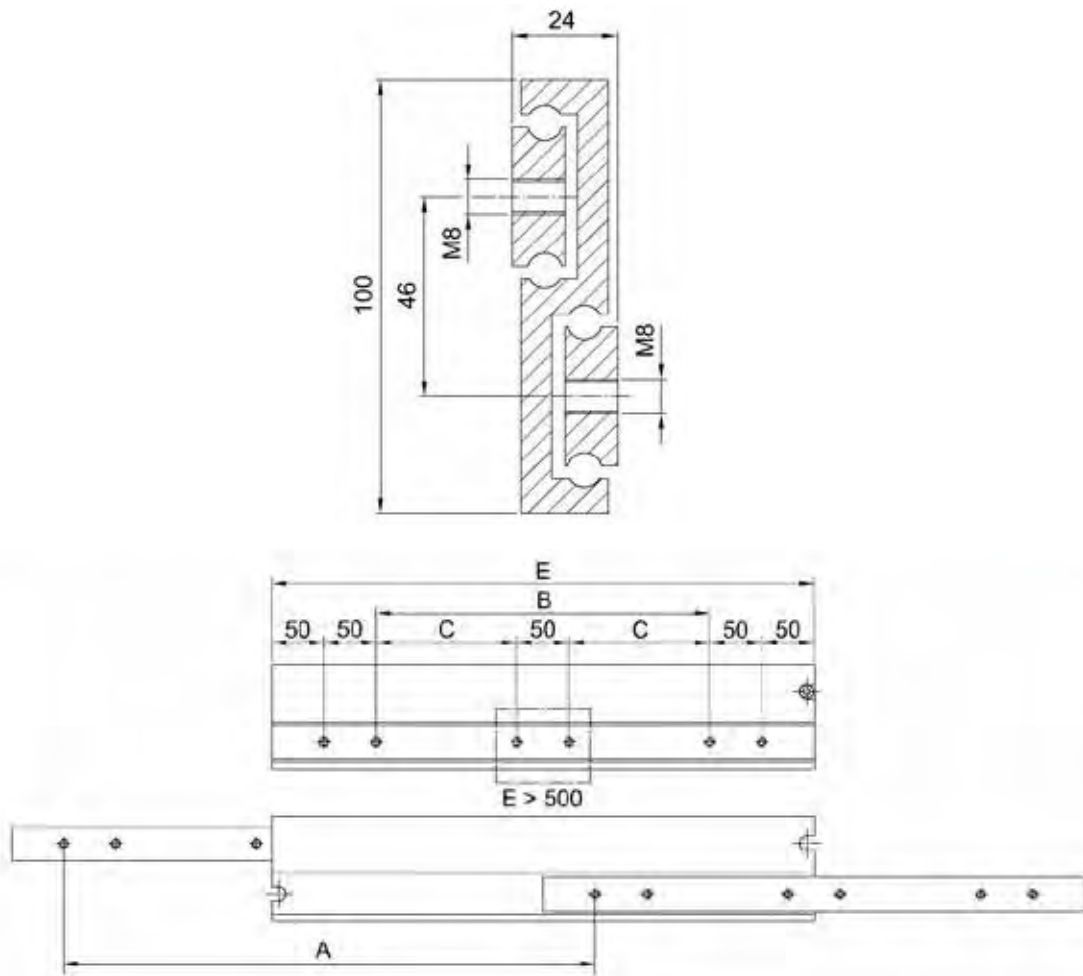

Load Table

Order Number	Hole separation (mm)		Installation length (mm)	Extension length (mm)	Net weight (kg)	Maximum load/pair (N)
	B	C				
NTVZ100-24-400	200		400	400	5.7	3200
NTVZ100-24-450	250		450	450	6.4	3500
NTVZ100-24-500	300		500	500	7.1	3600
NTVZ100-24-550		150	550	550	7.8	3600
NTVZ100-24-600		175	600	600	8.5	3550
NTVZ100-24-650		200	650	650	9.3	3450
NTVZ100-24-700		225	700	700	10.0	3300
NTVZ100-24-750		250	750	750	10.7	3150
NTVZ100-24-800		275	800	800	11.4	3000
NTVZ100-24-850		300	850	850	12.1	2850
NTVZ100-24-900		325	900	900	12.8	2700
NTVZ100-24-950		350	950	950	13.4	2550
NTVZ100-24-1000		375	1000	1000	14.2	2400
NTVZ100-24-1100		425	1100	1100	15.6	2250
NTVZ100-24-1200		475	1200	1200	17.1	2100
NTVZ100-24-1300		525	1300	1300	18.5	1950
NTVZ100-24-1400		575	1400	1400	19.9	1850
NTVZ100-24-1500		625	1500	1500	21.3	1600

Ordercode and further options see last page. Your desired length is not listed in the table? No problem! Only the most common lengths are shown here. Please contact our application technology division.

FULL EXTENSION

NTVZ120-28

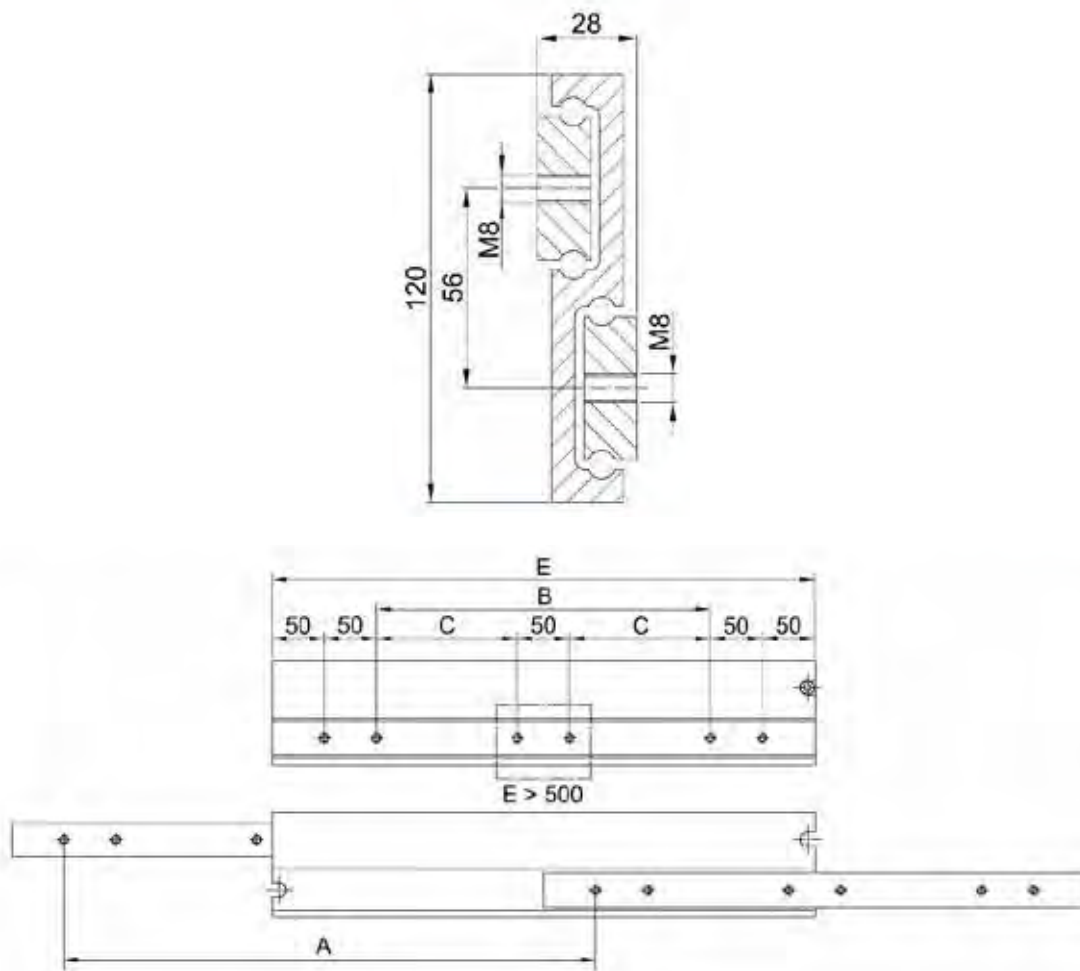

Load Table

Order Number	Hole separation (mm)		Installation length (mm)	Extension length (mm)	Net weight (kg)	Maximum load/pair (N)
	B	C	E	A		
NTVZ120-28-400	200		400	400	7.4	5250
NTVZ120-28-450	250		450	450	8.3	5350
NTVZ120-28-500	300		500	500	9.2	5400
NTVZ120-28-550		150	550	550	10.1	5500
NTVZ120-28-600		175	600	600	11.0	5400
NTVZ120-28-650		200	650	650	12.0	5350
NTVZ120-28-700		225	700	700	12.9	5250
NTVZ120-28-750		250	750	750	13.8	5100
NTVZ120-28-800		275	800	800	14.7	4900
NTVZ120-28-850		300	850	850	15.7	4700
NTVZ120-28-900		325	900	900	16.6	4500
NTVZ120-28-950		350	950	950	17.5	4300
NTVZ120-28-1000		375	1000	1000	18.4	4050
NTVZ120-28-1100		425	1100	1100	20.3	3700
NTVZ120-28-1200		475	1200	1200	22.1	3300
NTVZ120-28-1300		525	1300	1300	24.0	2900
NTVZ120-28-1400		575	1400	1400	25.8	2500
NTVZ120-28-1500		625	1500	1500	27.6	2100

Ordercode and further options see last page. Your desired length is not listed in the table? No problem! Only the most common lengths are shown here. Please contact our application technology division.

NTVZ150-30

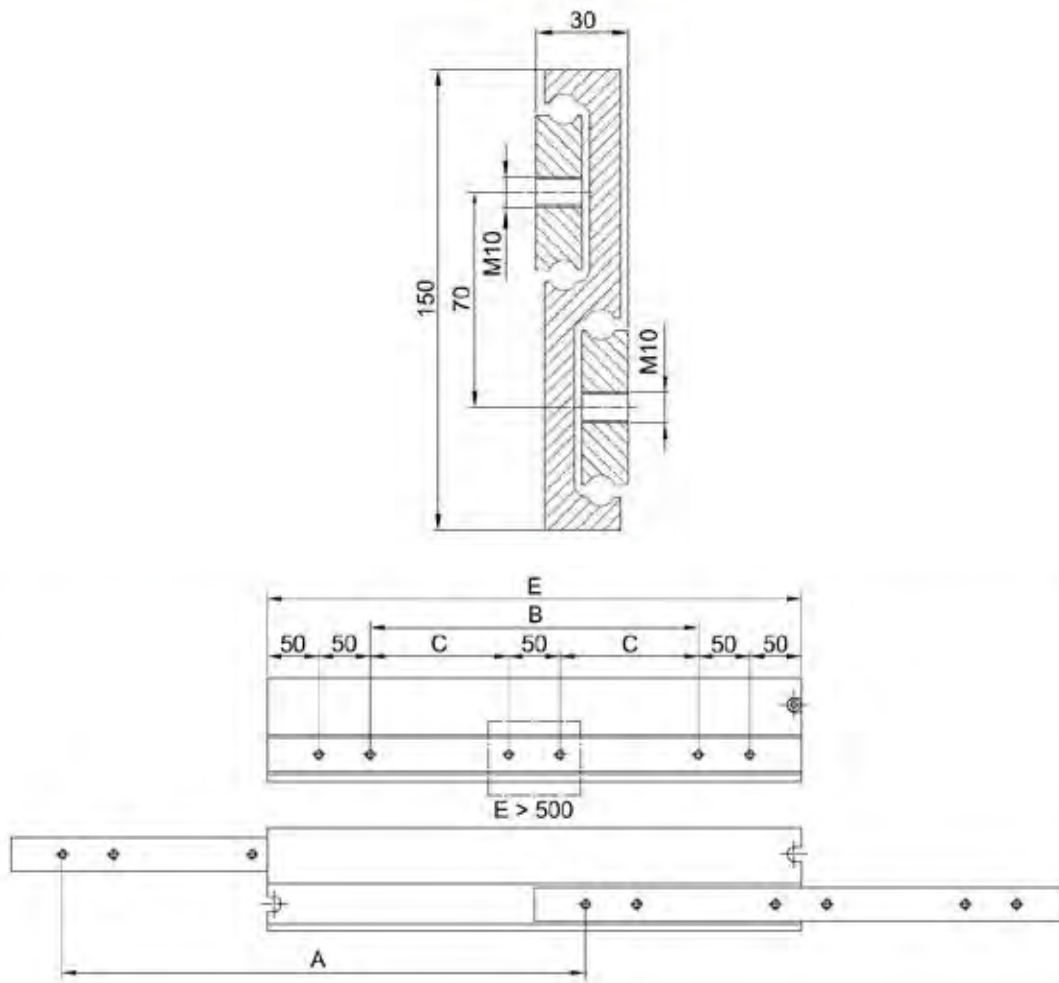

Load Table

Order Number	Hole separation (mm)		Installation length (mm)	Extension length (mm)	Net weight (kg)	Maximum load/pair (N)
	B	C	E	A		
NTVZ150-30-400	200		400	400	10.9	6500
NTVZ150-30-450	250		450	450	12.3	7000
NTVZ150-30-500	300		500	500	13.6	7200
NTVZ150-30-550		150	550	550	15.0	7400
NTVZ150-30-600		175	600	600	16.4	7400
NTVZ150-30-650		200	650	650	17.7	7300
NTVZ150-30-700		225	700	700	19.1	7150
NTVZ150-30-750		250	750	750	20.5	6950
NTVZ150-30-800		275	800	800	21.8	6750
NTVZ150-30-850		300	850	850	23.2	6550
NTVZ150-30-900		325	900	900	24.6	6300
NTVZ150-30-950		350	950	950	26.0	6100
NTVZ150-30-1000		375	1000	1000	27.3	5800
NTVZ150-30-1100		425	1100	1100	30.0	5450
NTVZ150-30-1200		475	1200	1200	32.7	5000
NTVZ150-30-1300		525	1300	1300	35.5	4550
NTVZ150-30-1400		575	1400	1400	38.2	4100
NTVZ150-30-1500		625	1500	1500	40.9	3650

Ordercode and further options see last page. Your desired length is not listed in the table? No problem! Only the most common lengths are shown here. Please contact our application technology division.

NOTES

A large grid of graph paper for taking notes, consisting of 20 columns and 40 rows of small squares.

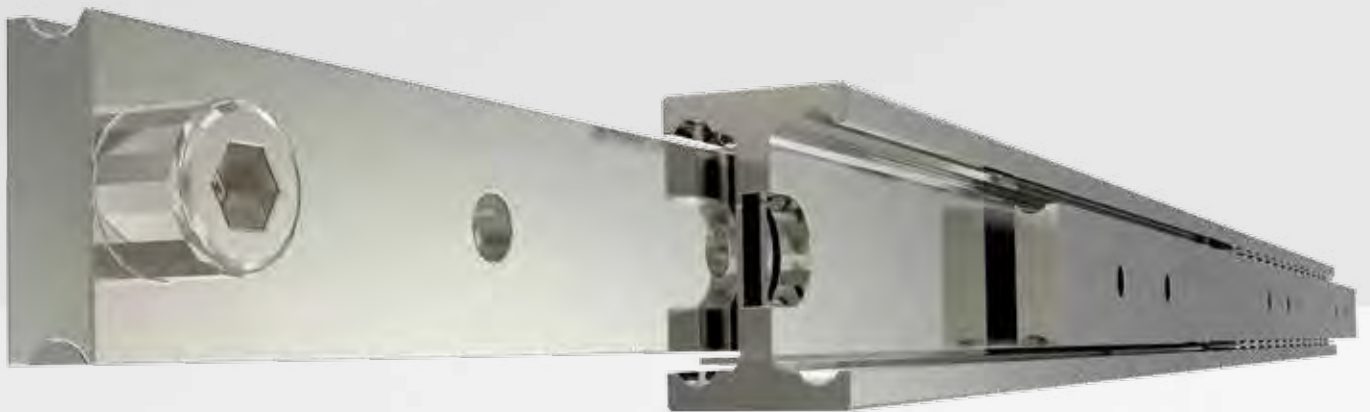

HEAVY DUTY EXTENSIONS



PAGE 54

4.1 PRODUCT OVERVIEW

PAGE 58

4.2 HEAVY DUTY EXTENSIONS

- NTS30-26
- NTS33-30
- NTS33-34
- NTS35-30
- NTS40-26
- NTS50-30
- NTS60-32
- NTS70-36
- NTS80-36
- NTS100-44
- NTS120-44
- NTS150-56
- NTS200-72
- NTS250-74
- NTS250-104

PRODUCT OVERVIEW

HEAVY DUTY EXTENSIONS

NTS30-26

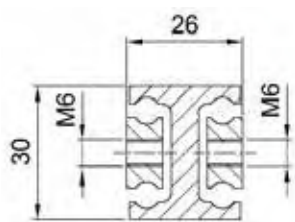

NTS33-30

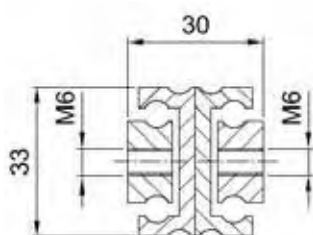

NTS33-34

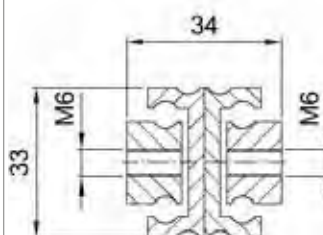

NTS35-30

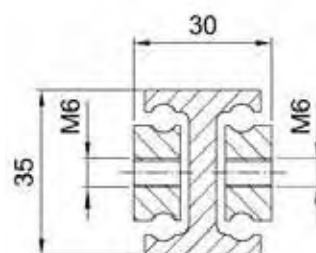

NTS40-26

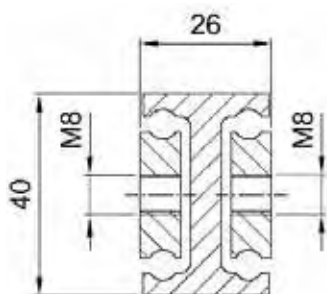

NTS50-30

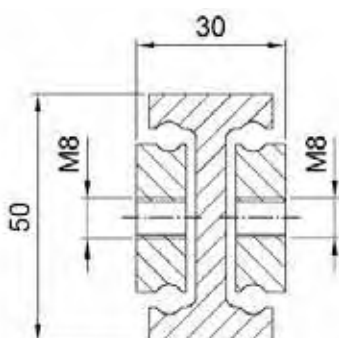

NTS60-32

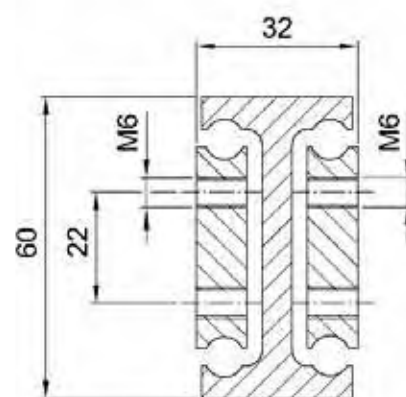

HEAVY DUTY EXTENSIONS

NTS70-36

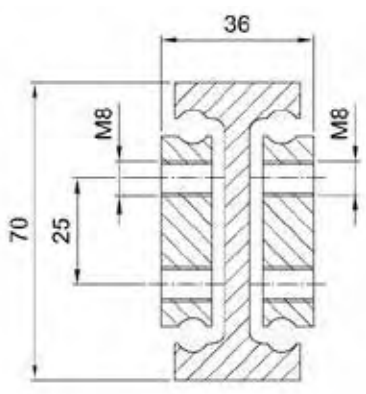

NTS80-36

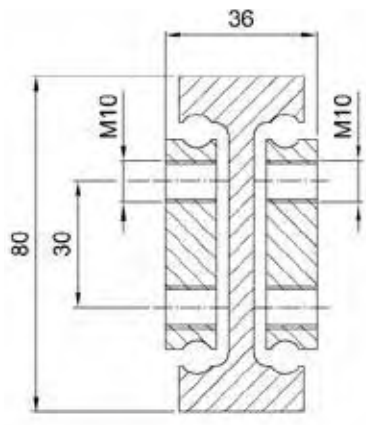

NTS100-44

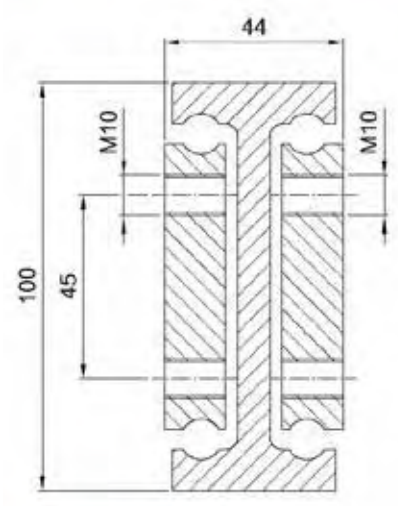

NTS120-44

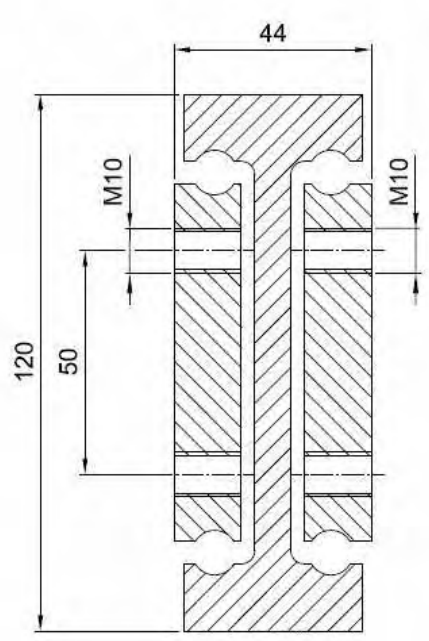

NTS150-56

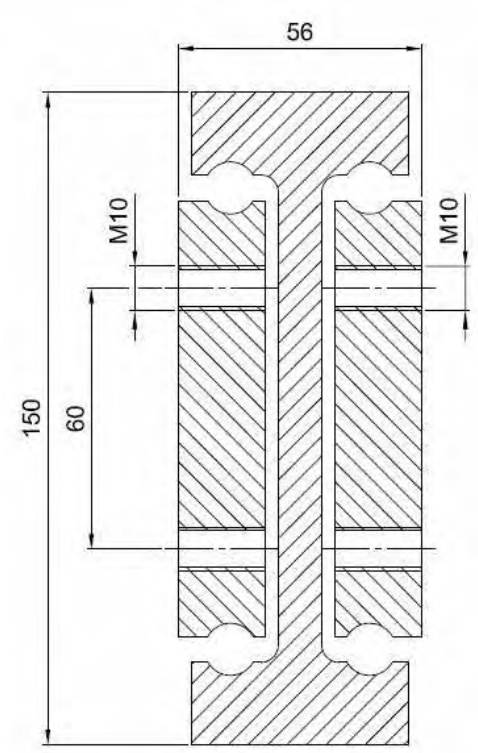

PRODUCT OVERVIEW

HEAVY DUTY EXTENSIONS

NTS200-72

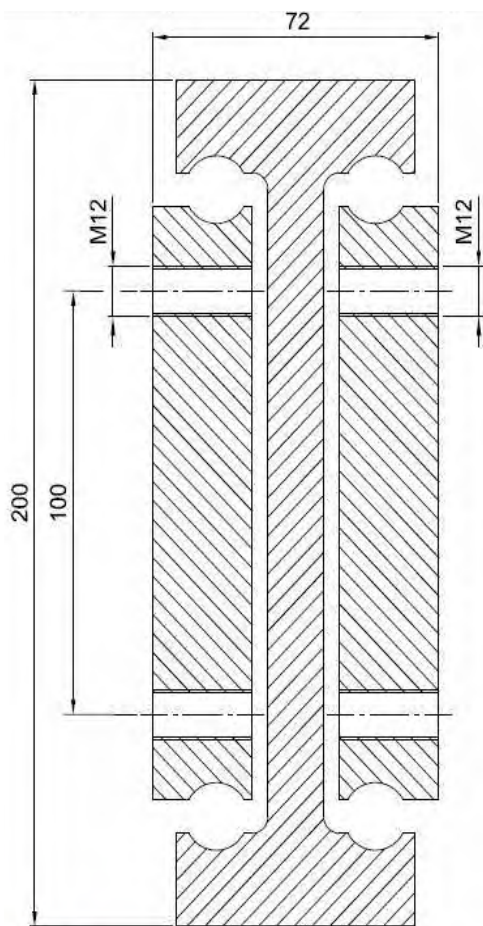

NTS250-74

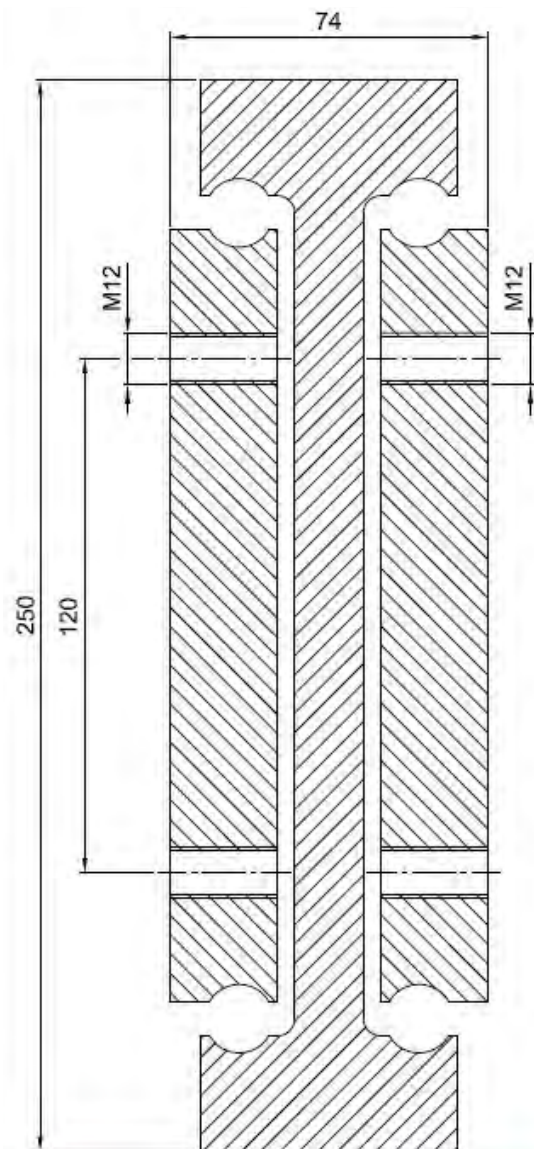

HEAVY DUTY EXTENSIONS

NTS250-104

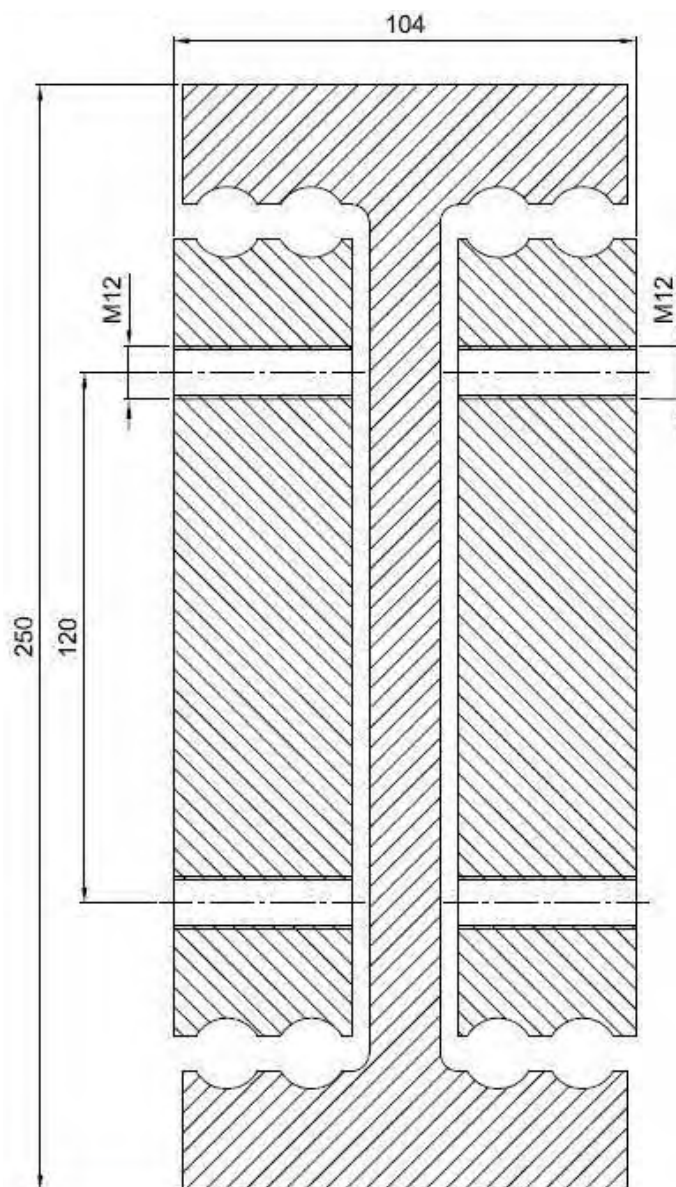

HEAVY DUTY EXTENSION

NTS30-26

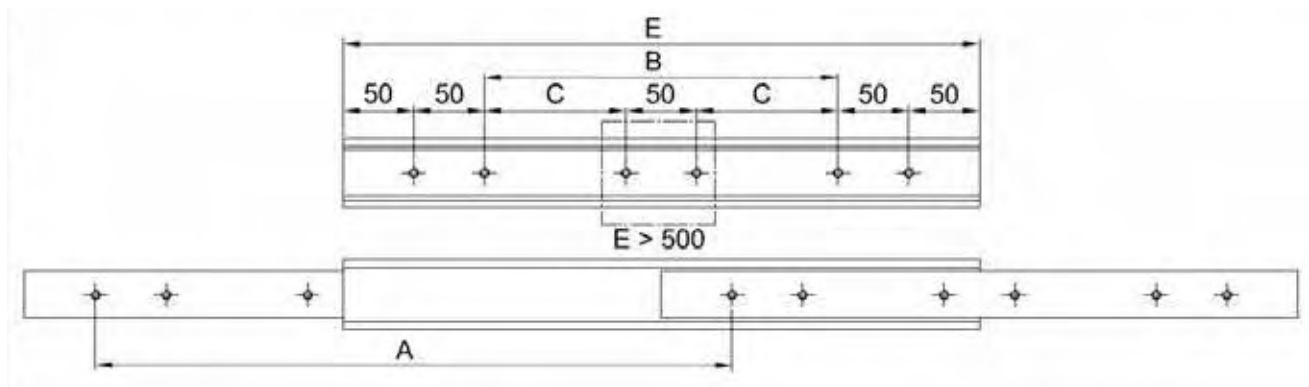
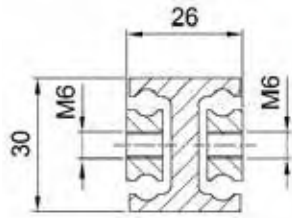

Load Table

Order Number	Hole separation (mm)		Installation length (mm)	Extension length (mm)	Net weight (kg)	Maximum load/pair (N)
	B	C	E	A		
NTS30-26-250	50		250	250	1.2	1000
NTS30-26-300	100		300	300	1.4	1050
NTS30-26-350	150		350	350	1.6	1100
NTS30-26-400	200		400	400	1.8	1100
NTS30-26-450	250		450	450	2.1	1050
NTS30-26-500	300		500	500	2.3	1050
NTS30-26-550		150	550	550	2.5	1000
NTS30-26-600		175	600	600	2.8	1000
NTS30-26-650		200	650	650	3.0	950
NTS30-26-700		225	700	700	3.2	900
NTS30-26-750		250	750	750	3.5	850
NTS30-26-800		275	800	800	3.7	800
NTS30-26-850		300	850	850	3.9	750
NTS30-26-900		325	900	900	4.1	700
NTS30-26-950		350	950	950	4.4	650
NTS30-26-1000		375	1000	1000	4.6	600

Note: This telescopic rail is only available in NX2, NX4 or A.

Ordercode and further options see last page. Your desired length is not listed in the table? No problem! Only the most common lengths are shown here. Please contact our application technology division.

NTS33-30

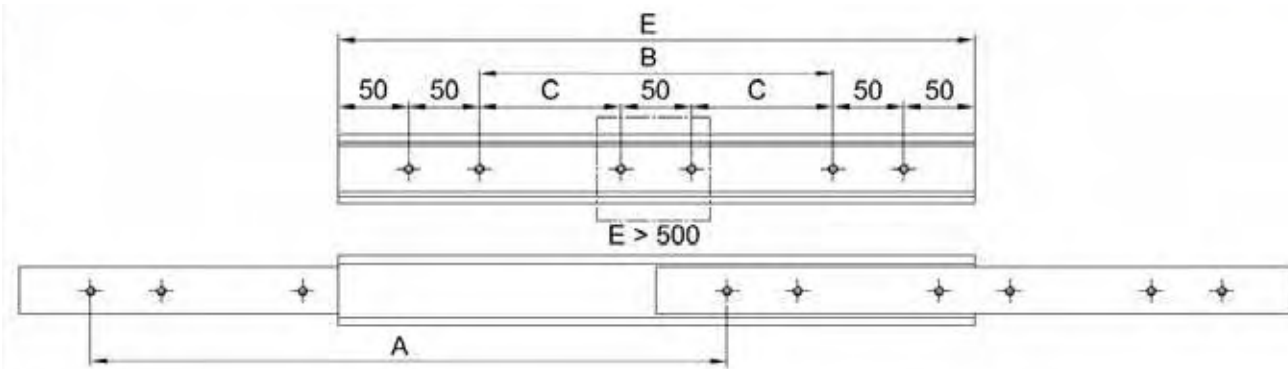
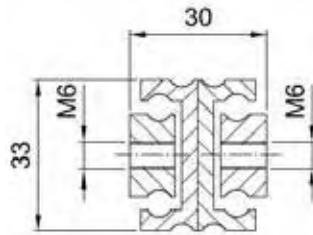

Load Table

Order Number	Hole separation (mm)		Installation length (mm)	Extension length (mm)	Net weight (kg)	Maximum load/pair (N)
	B	C	E	A		
NTS33-30-250	50		250	250	1.6	1200
NTS33-30-300	100		300	300	2.0	1250
NTS33-30-350	150		350	350	2.3	1300
NTS33-30-400	200		400	400	2.6	1300
NTS33-30-450	250		450	450	3.0	1250
NTS33-30-500	300		500	500	3.3	1250
NTS33-30-550		150	550	550	3.6	1200
NTS33-30-600		175	600	600	3.9	1200
NTS33-30-650		200	650	650	4.3	1150
NTS33-30-700		225	700	700	4.6	1100
NTS33-30-750		250	750	750	4.9	1050
NTS33-30-800		275	800	800	5.2	1000
NTS33-30-850		300	850	850	5.5	950
NTS33-30-900		325	900	900	5.8	900
NTS33-30-950		350	950	950	6.1	850
NTS33-30-1000		375	1000	1000	6.4	800

Ordercode and further options see last page. Your desired length is not listed in the table? No problem! Only the most common lengths are shown here. Please contact our application technology division.

HEAVY DUTY EXTENSION

NTS33-34

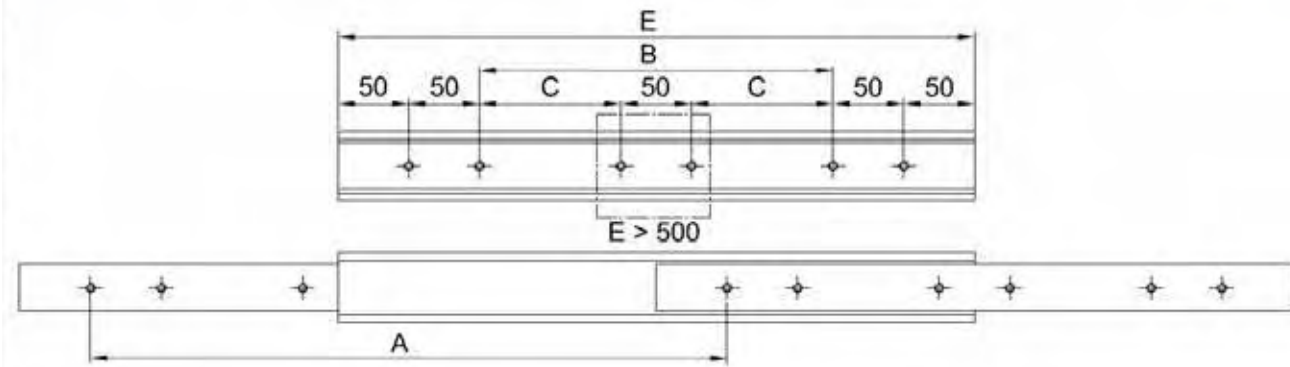
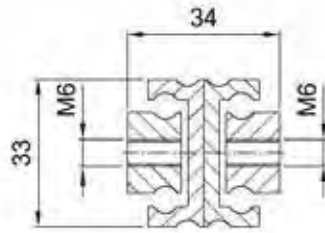

Load Table

Order Number	Hole separation (mm)		Installation length (mm)	Extension length (mm)	Net weight (kg)	Maximum load/pair (N)
	B	C	E	A		
NTS33-34-250	50		250	250	1.6	1450
NTS33-34-300	100		300	300	1.9	1500
NTS33-34-350	150		350	350	2.2	1550
NTS33-34-400	200		400	400	2.6	1600
NTS33-34-450	250		450	450	2.9	1600
NTS33-34-500	300		500	500	3.2	1600
NTS33-34-550		150	550	550	3.5	1550
NTS33-34-600		175	600	600	3.8	1500
NTS33-34-650		200	650	650	4.2	1400
NTS33-34-700		225	700	700	4.5	1350
NTS33-34-750		250	750	750	4.8	1300
NTS33-34-800		275	800	800	5.1	1250
NTS33-34-850		300	850	850	5.4	1200
NTS33-34-900		325	900	900	5.8	1150
NTS33-34-950		350	950	950	6.0	1100
NTS33-34-1000		375	1000	1000	6.4	1000

Ordercode and further options see last page. Your desired length is not listed in the table? No problem! Only the most common lengths are shown here. Please contact our application technology division.

NTS35-30

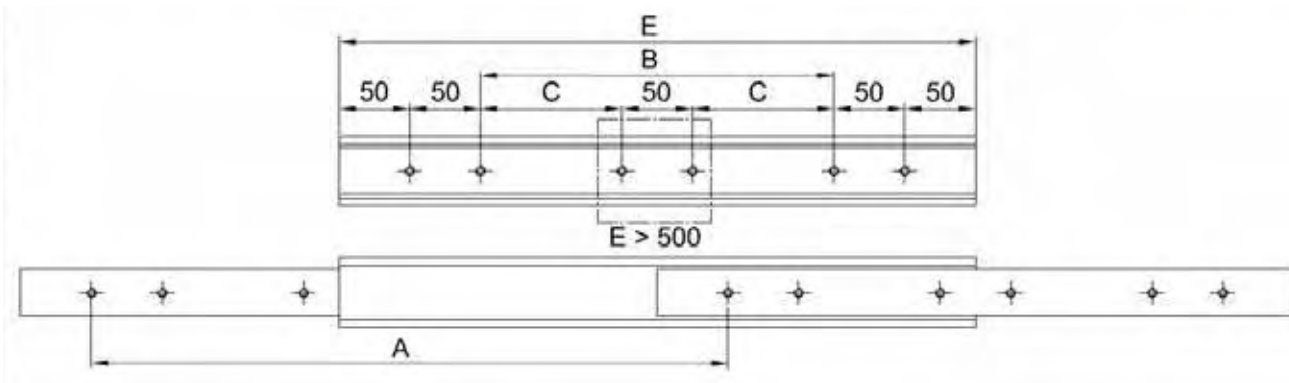
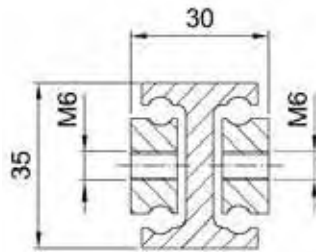

Load Table

Order Number	Hole separation (mm)		Installation length (mm)	Extension length (mm)	Net weight (kg)	Maximum load/pair (N)
	B	C	E	A		
NTS35-30-250	50		250	250	1.6	1300
NTS35-30-300	100		300	300	1.9	1350
NTS35-30-350	150		350	350	2.2	1400
NTS35-30-400	200		400	400	2.5	1400
NTS35-30-450	250		450	450	2.8	1350
NTS35-30-500	300		500	500	3.1	1350
NTS35-30-550		150	550	550	3.4	1300
NTS35-30-600		175	600	600	3.7	1300
NTS35-30-650		200	650	650	4.0	1250
NTS35-30-700		225	700	700	4.3	1200
NTS35-30-750		250	750	750	4.6	1150
NTS35-30-800		275	800	800	5.0	1100
NTS35-30-850		300	850	850	5.3	1050
NTS35-30-900		325	900	900	5.6	1000
NTS35-30-950		350	950	950	5.9	950
NTS35-30-1000		375	1000	1000	6.2	900

Note: This telescopic rail is only available in NX2, NX4 or A.

Ordercode and further options see last page. Your desired length is not listed in the table? No problem! Only the most common lengths are shown here. Please contact our application technology division.

HEAVY DUTY EXTENSION

NTS40-26

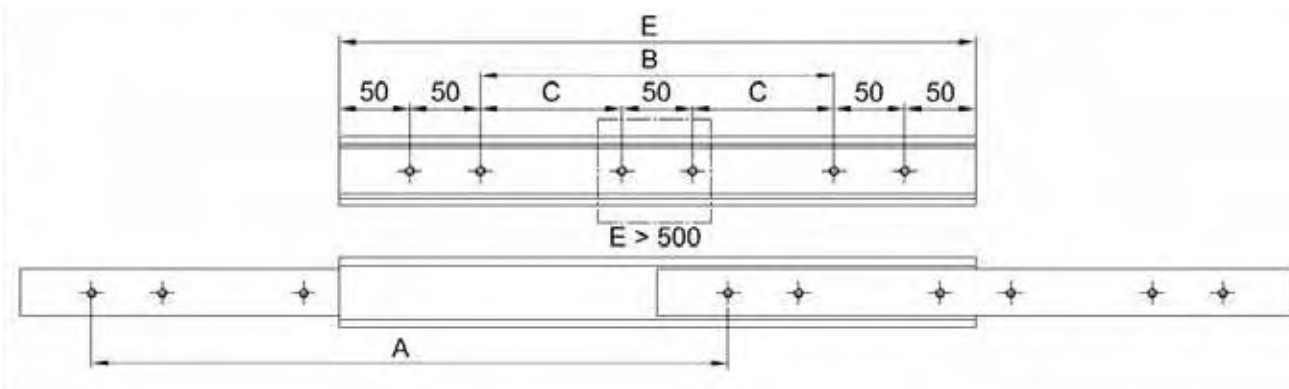
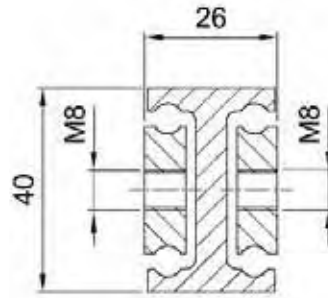

Load Table

Order Number	Hole separation (mm)		Installation length (mm)	Extension length (mm)	Net weight (kg)	Maximum load/pair (N)
	B	C	E	A		
NTS40-26-250	50		250	250	1.6	1400
NTS40-26-300	100		300	300	1.9	1500
NTS40-26-350	150		350	350	2.3	1600
NTS40-26-400	200		400	400	2.5	1550
NTS40-26-450	250		450	450	2.8	1500
NTS40-26-500	300		500	500	3.1	1450
NTS40-26-550		150	550	550	3.5	1400
NTS40-26-600		175	600	600	3.8	1350
NTS40-26-650		200	650	650	4.1	1300
NTS40-26-700		225	700	700	4.4	1250
NTS40-26-750		250	750	750	4.7	1200
NTS40-26-800		275	800	800	5.0	1150
NTS40-26-850		300	850	850	5.3	1100
NTS40-26-900		325	900	900	5.6	1050
NTS40-26-950		350	950	950	5.9	1000
NTS40-26-1000		375	1000	1000	6.2	950
NTS40-26-1050		400	1050	1050	6.5	900
NTS40-26-1100		425	1100	1100	6.8	850
NTS40-26-1150		450	1150	1150	7.1	775
NTS40-26-1200		475	1200	1200	7.4	700
NTS40-26-1250		500	1250	1250	7.7	600

Ordercode and further options see last page. Your desired length is not listed in the table? No problem! Only the most common lengths are shown here. Please contact our application technology division.

NTS50-30

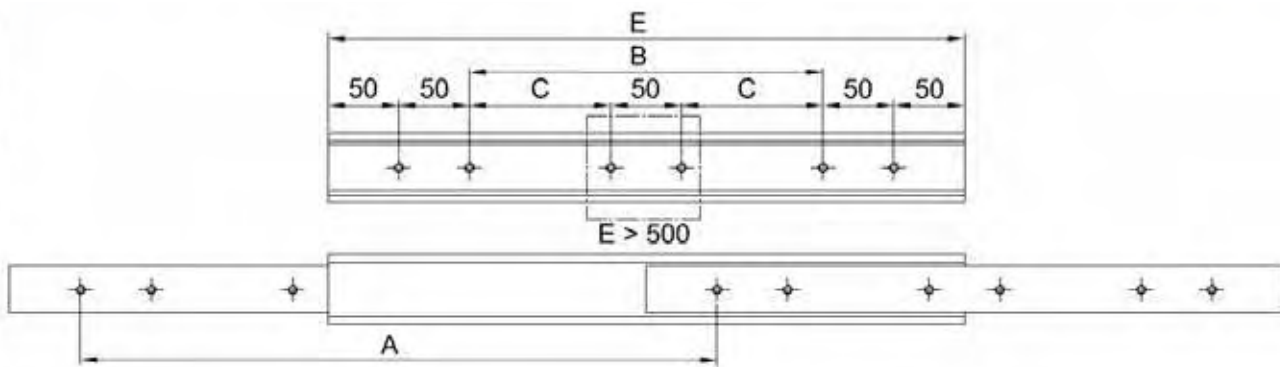
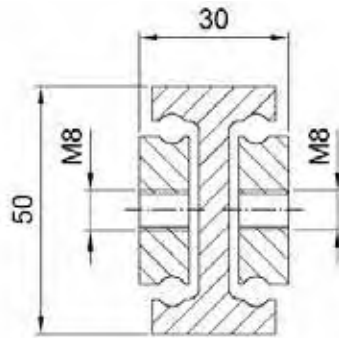

Load Table

Order Number	Hole separation (mm)		Installation length (mm)	Extension length (mm)	Net weight (kg)	Maximum load/pair (N)
	B	C				
NTS50-30-250	50		250	250	2.4	2000
NTS50-30-300	100		300	300	2.9	2300
NTS50-30-350	150		350	350	3.2	2500
NTS50-30-400	200		400	400	3.7	2650
NTS50-30-450	250		450	450	4.1	2750
NTS50-30-500	300		500	500	4.6	2800
NTS50-30-550		150	550	550	5.0	2700
NTS50-30-600		175	600	600	5.5	2700
NTS50-30-650		200	650	650	6.0	2650
NTS50-30-700		225	700	700	6.4	2550
NTS50-30-750		250	750	750	6.9	2450
NTS50-30-800		275	800	800	7.3	2350
NTS50-30-850		300	850	850	7.8	2250
NTS50-30-900		325	900	900	8.3	2150
NTS50-30-950		350	950	950	8.7	2050
NTS50-30-1000		375	1000	1000	9.2	1950
NTS50-30-1050		400	1050	1050	9.6	1850
NTS50-30-1100		425	1100	1100	10.1	1750
NTS50-30-1150		450	1150	1150	10.6	1700
NTS50-30-1200		475	1200	1200	11.0	1650
NTS50-30-1250		500	1250	1250	11.5	1500

Ordercode and further options see last page. Your desired length is not listed in the table? No problem! Only the most common lengths are shown here. Please contact our application technology division.

HEAVY DUTY EXTENSION

NTS60-32

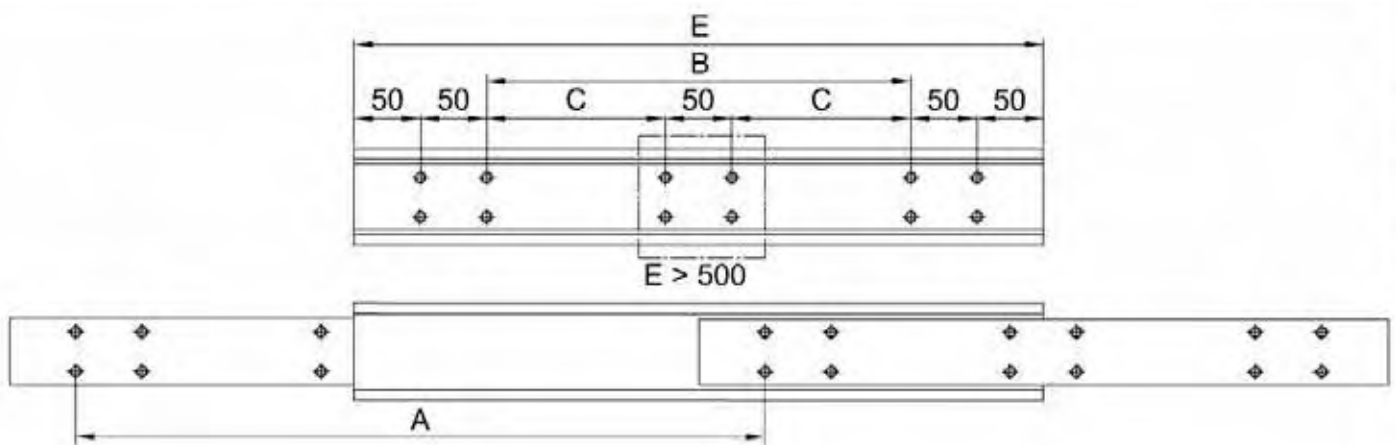
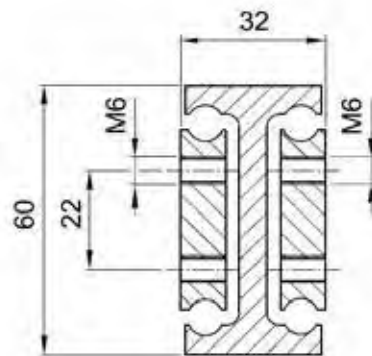

Load Table

Order Number	Hole separation (mm)		Installation length (mm)	Extension length (mm)	Net weight (kg)	Maximum load/pair (N)
	B	C	E	A		
NTS60-32-400	200		400	400	4.6	5250
NTS60-32-450	250		450	450	5.2	5350
NTS60-32-500	300		500	500	5.8	5400
NTS60-32-550		150	550	550	6.4	5500
NTS60-32-600		175	600	600	7.0	5400
NTS60-32-660		200	650	650	7.6	5350
NTS60-32-700		225	700	700	8.2	5350
NTS60-32-750		250	750	750	8.7	5100
NTS60-32-800		275	800	800	9.3	4900
NTS60-32-850		300	850	850	9.9	4700
NTS60-32-900		325	900	900	10.5	4500
NTS60-32-950		350	950	950	11.1	4300
NTS60-32-1000		375	1000	1000	11.7	4050
NTS60-32-1050		400	1050	1050	12.3	3850
NTS60-32-1100		425	1100	1100	12.9	3700
NTS60-32-1150		450	1150	1150	13.5	3500
NTS60-32-1200		475	1200	1200	14.0	3300
NTS60-32-1250		500	1250	1250	14.6	3100
NTS60-32-1300		525	1300	1300	15.2	2900
NTS60-32-1400		550	1400	1400	16.4	2500

Ordercode and further options see last page. Your desired length is not listed in the table? No problem! Only the most common lengths are shown here. Please contact our application technology division.

NTS70-36

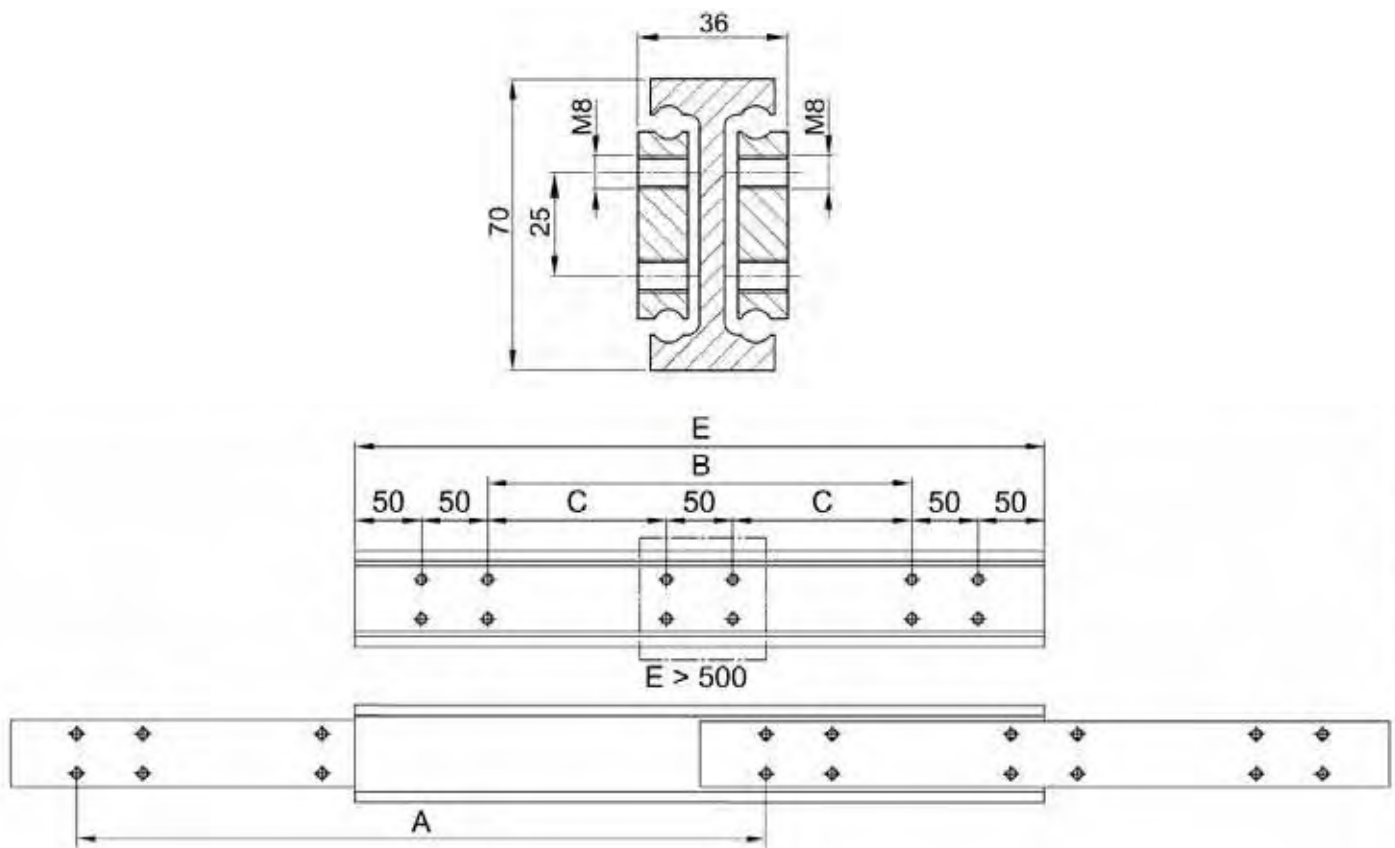

Load Table

Order Number	Hole separation (mm)		Installation length (mm)	Extension length (mm)	Net weight (kg)	Maximum load/pair (N)
	B	C	E	A		
NTS70-36-400	200		400	400	5.8	6500
NTS70-36-450	250		450	450	6.6	7000
NTS70-36-500	300		500	500	7.3	7200
NTS70-36-550		150	550	550	7.9	7400
NTS70-36-600		175	600	600	8.5	7400
NTS70-36-660		200	650	650	9.1	7300
NTS70-36-700		225	700	700	9.7	7150
NTS70-36-750		250	750	750	10.2	6950
NTS70-36-800		275	800	800	10.8	6750
NTS70-36-850		300	850	850	11.4	6550
NTS70-36-900		325	900	900	12.0	6300
NTS70-36-950		350	950	950	12.6	6100
NTS70-36-1000		375	1000	1000	13.2	5800
NTS70-36-1050		400	1050	1050	13.9	5600
NTS70-36-1100		425	1100	1100	14.5	5450
NTS70-36-1150		450	1150	1150	15.2	5200
NTS70-36-1200		475	1200	1200	16.7	5000
NTS70-36-1250		500	1250	1250	17.1	4775
NTS70-36-1300		525	1300	1300	17.5	4550
NTS70-36-1400		575	1400	1400	19.0	4100
NTS70-36-1500		625	1500	1500	20.5	3650

Ordercode and further options see last page. Your desired length is not listed in the table? No problem! Only the most common lengths are shown here. Please contact our application technology division.

HEAVY DUTY EXTENSION

NTS80-36

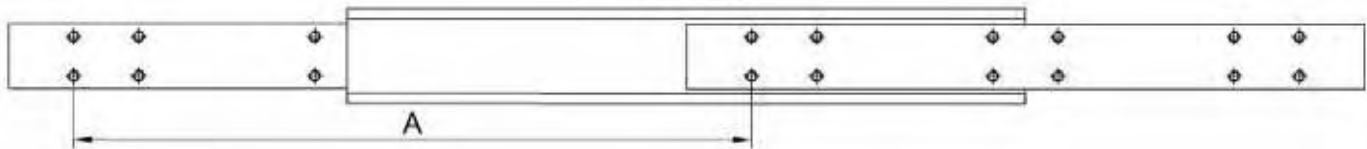
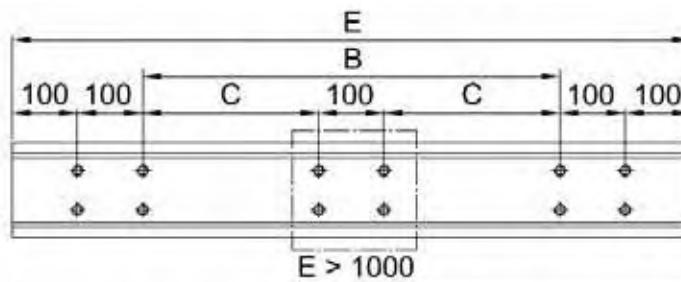
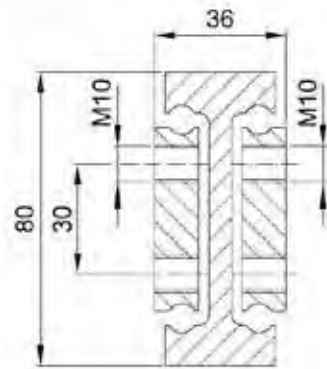

Load Table

Order Number	Hole separation (mm)		Installation length (mm)	Extension length (mm)	Net weight (kg)	Maximum load/pair (N)
	B	C	E	A		
NTS80-36-500	100		500	500	8.8	9000
NTS80-36-550	150		550	550	9.6	9250
NTS80-36-600	200		600	600	10.5	9350
NTS80-36-650	250		650	650	11.4	9200
NTS80-36-700	300		700	700	12.3	9050
NTS80-36-750	350		750	750	13.1	8800
NTS80-36-800	400		800	800	14.0	8600
NTS80-36-850	450		850	850	14.9	8350
NTS80-36-900	500		900	900	15.8	8100
NTS80-36-950	550		950	950	16.6	7850
NTS80-36-1000	600		1000	1000	17.5	7650
NTS80-36-1100		300	1100	1100	19.3	7150
NTS80-36-1200		350	1200	1200	21.0	6700
NTS80-36-1300		400	1300	1300	22.8	6200
NTS80-36-1400		450	1400	1400	24.5	5700
NTS80-36-1500		500	1500	1500	26.3	5200
NTS80-36-1600		550	1600	1600	28.0	4600
NTS80-36-1700		600	1700	1700	29.8	4100
NTS80-36-1800		650	1800	1800	31.5	3600
NTS80-36-1900		700	1900	1900	33.3	3000
NTS80-36-2000		750	2000	2000	35.0	2600

Ordercode and further options see last page. Your desired length is not listed in the table? No problem! Only the most common lengths are shown here. Please contact our application technology division.

NTS100-44

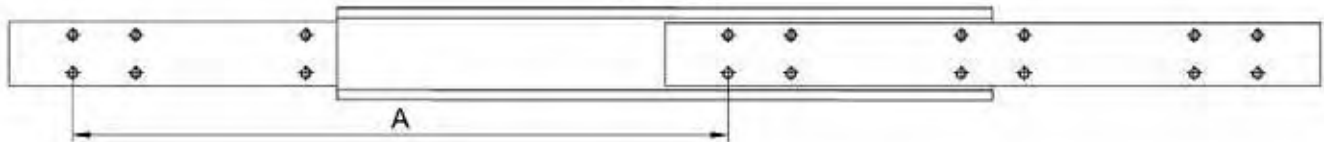
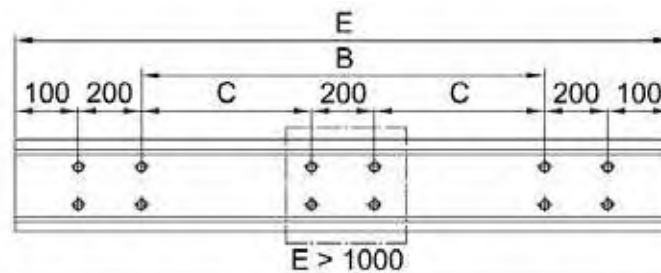
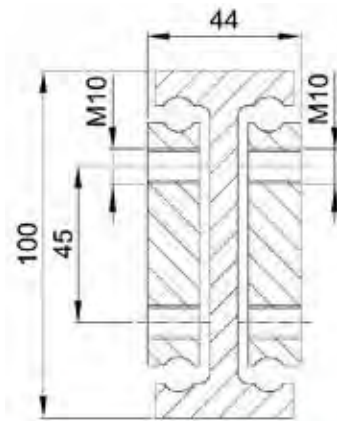

Load Table

Order Number	Hole separation (mm)		Installation length (mm)	Extension length (mm)	Net weight (kg)	Maximum load/pair (N)
	B	C	E	A		
NTS100-44-700	100		700	700	19.3	11000
NTS100-44-750	150		750	750	20.7	10750
NTS100-44-800	200		800	800	22.1	10500
NTS100-44-850	250		850	850	23.5	10250
NTS100-44-900	300		900	900	24.9	10000
NTS100-44-950	350		950	950	26.2	9750
NTS100-44-1000	400		1000	1000	27.6	9500
NTS100-44-1100		150	1100	1100	30.4	9000
NTS100-44-1200		200	1200	1200	33.2	8500
NTS100-44-1300		250	1300	1300	36.0	7900
NTS100-44-1400		300	1400	1400	38.7	7300
NTS100-44-1500		350	1500	1500	41.5	6700
NTS100-44-1600		400	1600	1600	44.2	6100
NTS100-44-1700		450	1700	1700	47.0	5450
NTS100-44-1800		500	1800	1800	49.7	4800
NTS100-44-1900		550	1900	1900	52.5	4100
NTS100-44-2000		600	2000	2000	55.3	3500
NTS100-44-2100		650	2100	2100	58.1	3000
NTS100-44-2200		700	2200	2200	60.9	2600
NTS100-44-2300		750	2300	2300	63.7	2300
NTS100-44-2400		800	2400	2400	66.5	2100

Ordercode and further options see last page. Your desired length is not listed in the table? No problem! Only the most common lengths are shown here. Please contact our application technology division.

HEAVY DUTY EXTENSION

NTS120-44

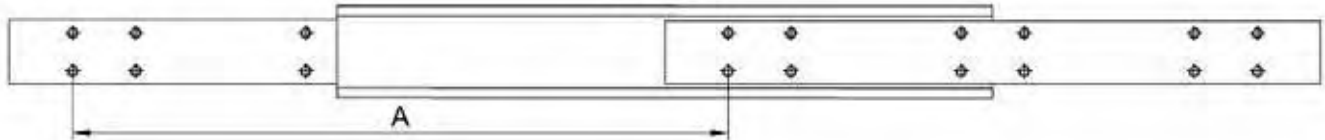
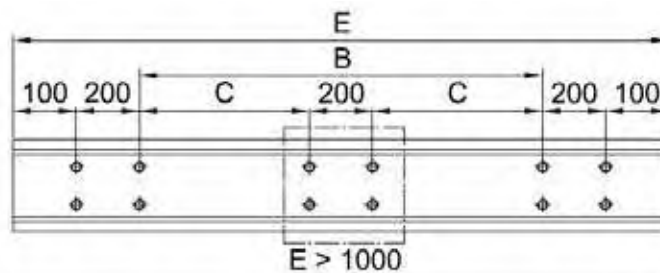
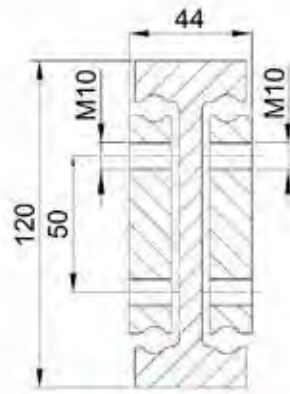

Load Table

Order Number	Hole separation (mm)		Installation length (mm)	Extension length (mm)	Net weight (kg)	Maximum load/pair (N)
	B	C	E	A		
NTS120-44-700	100		700	700	23.3	11500
NTS120-44-750	150		750	750	25.0	11800
NTS120-44-800	200		800	800	26.7	11800
NTS120-44-850	250		850	850	28.4	11550
NTS120-44-900	300		900	900	30.1	11300
NTS120-44-950	350		950	950	31.7	11050
NTS120-44-1000	400		1000	1000	33.4	10800
NTS120-44-1100		150	1100	1100	36.7	10300
NTS120-44-1200		200	1200	1200	40.1	9800
NTS120-44-1300		250	1300	1300	43.4	9200
NTS120-44-1400		300	1400	1400	46.8	8600
NTS120-44-1500		350	1500	1500	50.2	8000
NTS120-44-1600		400	1600	1600	53.5	7400
NTS120-44-1700		450	1700	1700	56.8	6800
NTS120-44-1800		500	1800	1800	60.2	6100
NTS120-44-1900		550	1900	1900	63.5	5400
NTS120-44-2000		600	2000	2000	66.9	4700
NTS120-44-2100		650	2100	2100	70.3	3900
NTS120-44-2200		700	2200	2200	73.7	3350
NTS120-44-2300		750	2300	2300	77.1	2950
NTS120-44-2400		800	2400	2400	80.5	2750

Ordercode and further options see last page. Your desired length is not listed in the table? No problem! Only the most common lengths are shown here. Please contact our application technology division.

NTS150-56

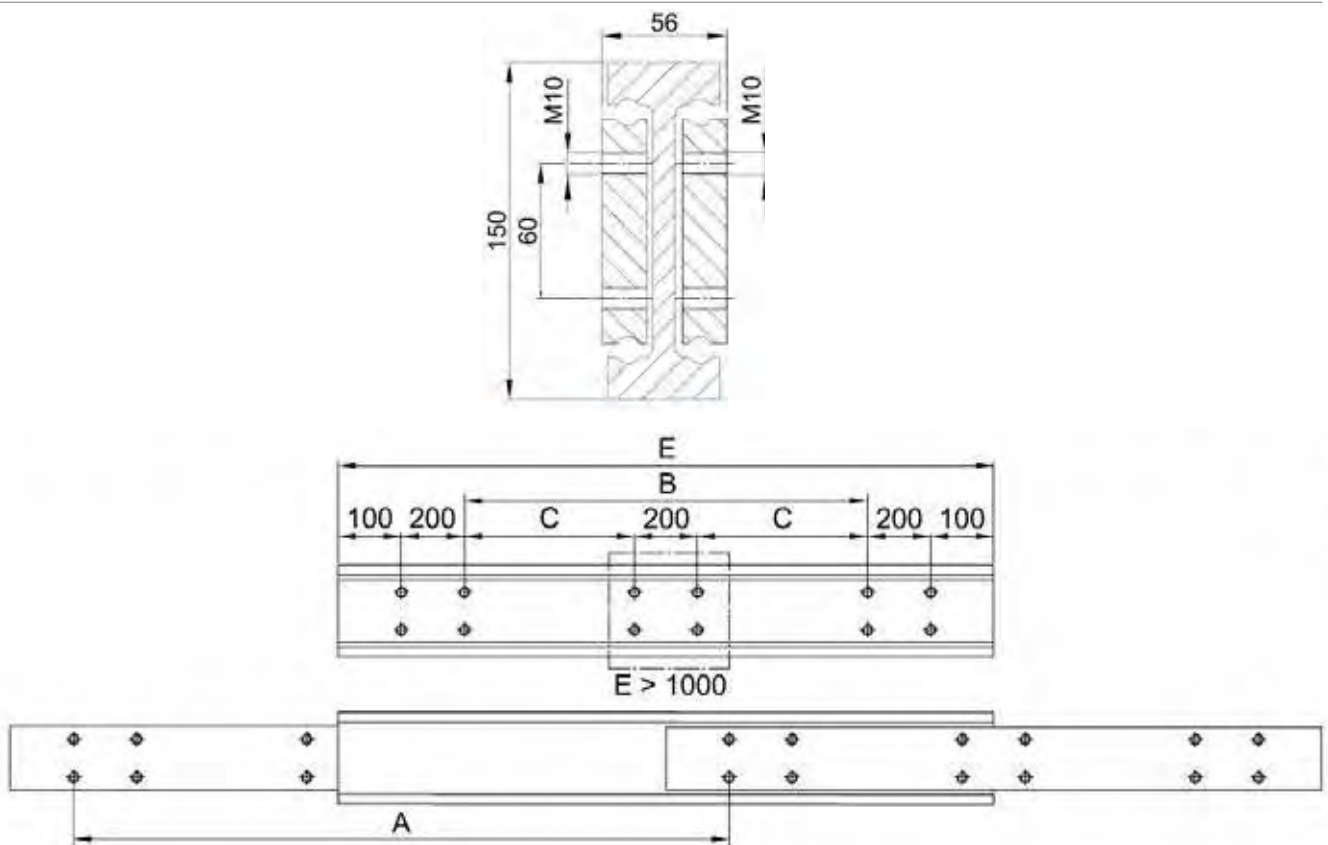

Load Table

Order Number	Hole separation (mm)		Installation length (mm)	Extension length (mm)	Net weight (kg)	Maximum load/pair (N)
	B	C				
NTS150-56-700	100		700	700	38.6	13900
NTS150-56-750	150		750	750	41.3	13700
NTS150-56-800	200		800	800	44.0	13500
NTS150-56-850	250		850	850	46.7	13300
NTS150-56-900	300		900	900	49.5	13100
NTS150-56-950	350		950	950	52.3	12800
NTS150-56-1000	400		1000	1000	55.0	12500
NTS150-56-1100		150	1100	1100	60.4	12100
NTS150-56-1200		200	1200	1200	66.0	11700
NTS150-56-1300		250	1300	1300	71.4	11300
NTS150-56-1400		300	1400	1400	76.9	10900
NTS150-56-1500		350	1500	1500	82.4	10400
NTS150-56-1600		400	1600	1600	87.9	9900
NTS150-56-1700		450	1700	1700	93.5	9250
NTS150-56-1800		500	1800	1800	99.0	8600
NTS150-56-1900		550	1900	1900	104.0	7800
NTS150-56-2000		600	2000	2000	109.9	7000
NTS150-56-2100		650	2100	2100	115.8	6200
NTS150-56-2200		700	2200	2200	121.7	5400
NTS150-56-2300		750	2300	2300	127.6	4600
NTS150-56-2400		800	2400	2400	133.5	3800

Ordercode and further options see last page. Your desired length is not listed in the table? No problem! Only the most common lengths are shown here. Please contact our application technology division.

HEAVY DUTY EXTENSION

NTS200-72

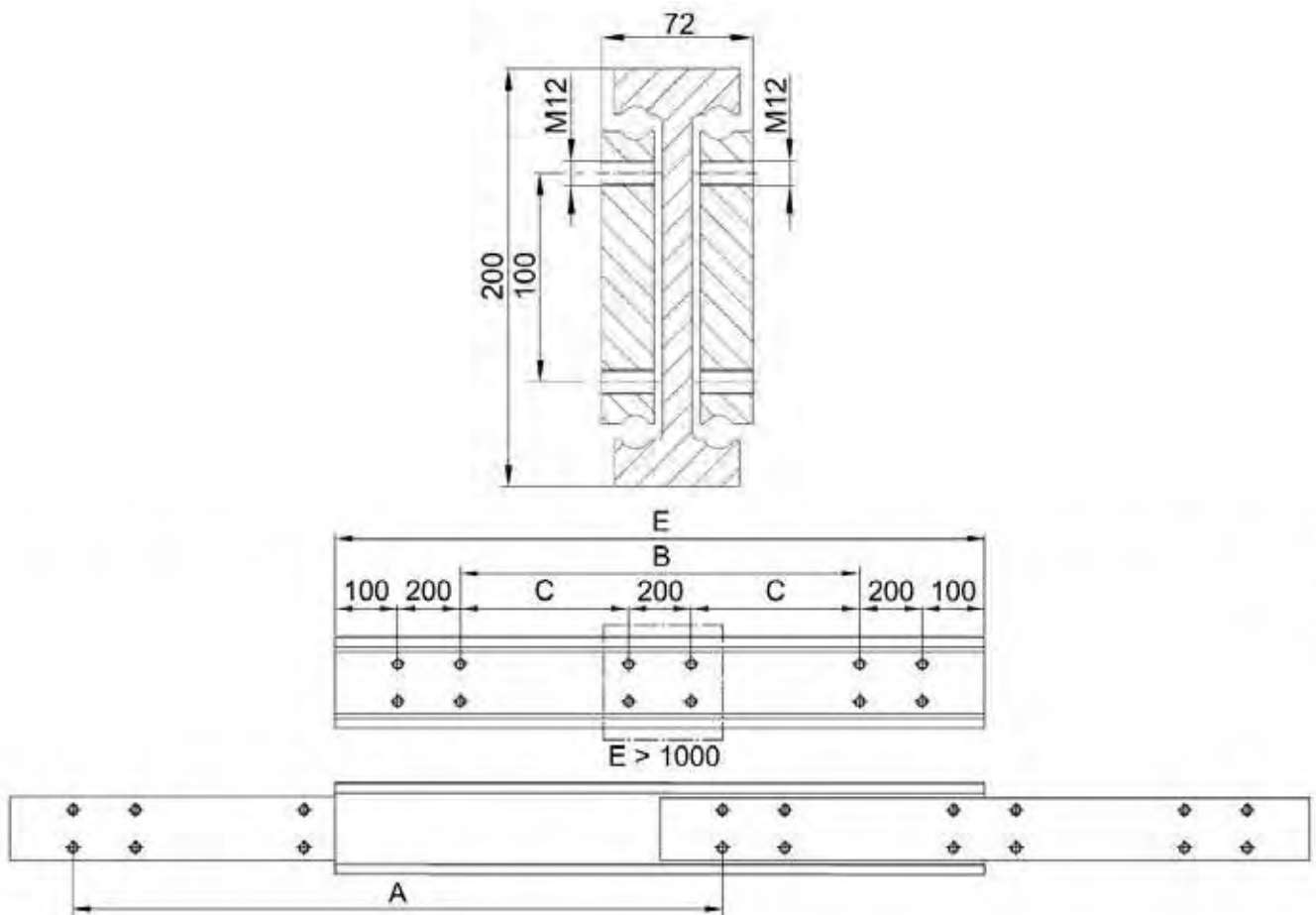

Load Table

Order Number	Hole separation (mm)		Installation length (mm)	Extension length (mm)	Net weight (kg)	Maximum load/pair (N)
	B	C	E	A		
NTS200-72-700	100		700	700	64.9	15000
NTS200-72-750	150		750	750	69.5	16000
NTS200-72-800	200		800	800	74.1	17000
NTS200-72-850	250		850	850	78.8	17500
NTS200-72-900	300		900	900	83.4	17500
NTS200-72-950	350		950	950	88.1	17200
NTS200-72-1000	400		1000	1000	92.7	17000
NTS200-72-1100		150	1100	1100	102.0	16500
NTS200-72-1200		200	1200	1200	111.2	16000
NTS200-72-1300		250	1300	1300	120.5	15500
NTS200-72-1400		300	1400	1400	129.7	15000
NTS200-72-1500		350	1500	1500	139.0	14400
NTS200-72-1600		400	1600	1600	148.3	13600
NTS200-72-1700		450	1700	1700	157.5	12800
NTS200-72-1800		500	1800	1800	166.8	12000
NTS200-72-1900		550	1900	1900	176.0	11000
NTS200-72-2000		600	2000	2000	185.3	10000
NTS200-72-2100		650	2100	2100	194.6	9000
NTS200-72-2200		700	2200	2200	203.9	8000
NTS200-72-2300		750	2300	2300	213.1	6700

Ordercode and further options see last page. Your desired length is not listed in the table? No problem! Only the most common lengths are shown here. Please contact our application technology division.

NTS250-74

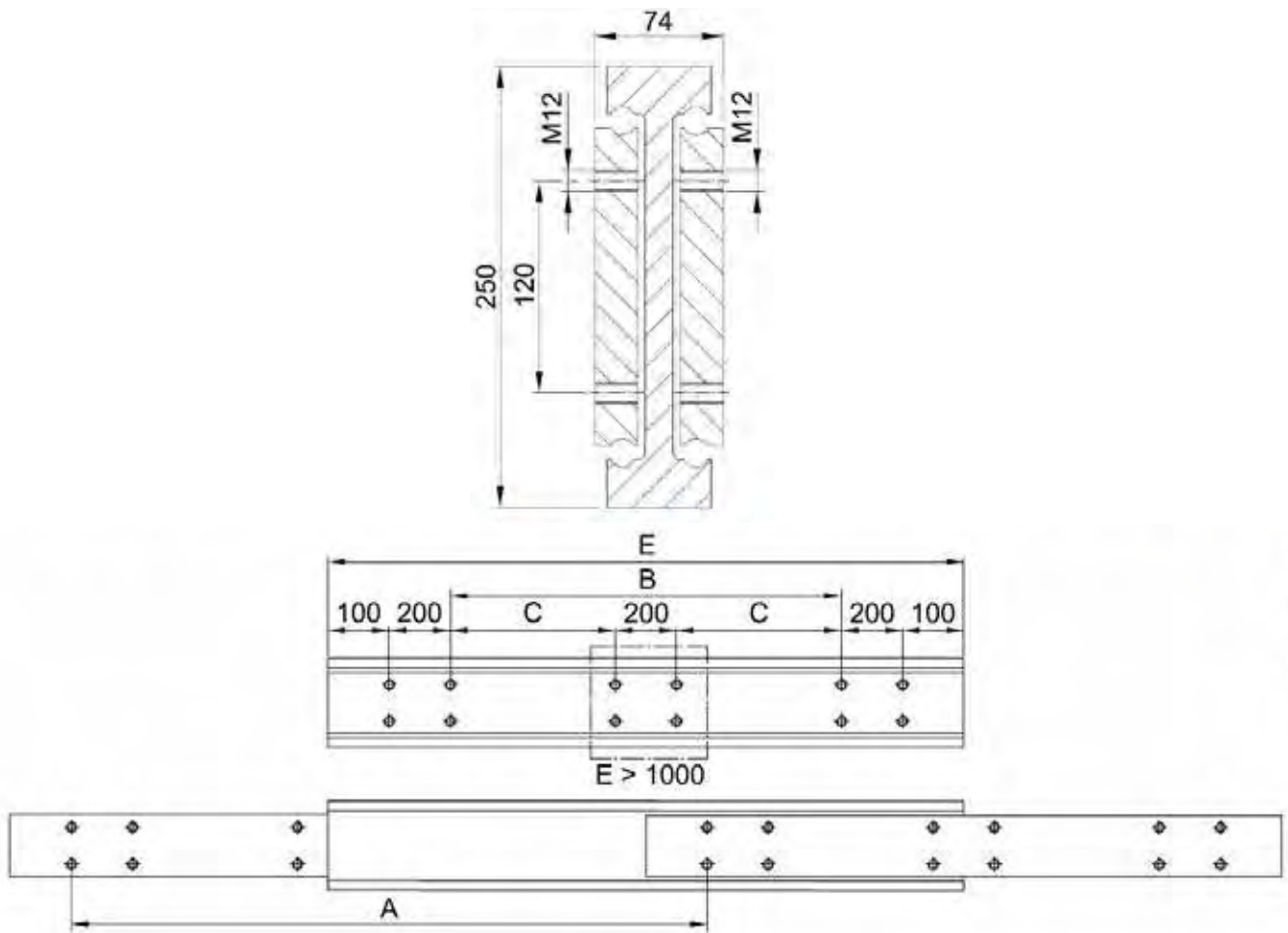

Order Number	Load Table					
	Hole separation (mm)		Installation length (mm)	Extension length (mm)	Net weight (kg)	Maximum load/pair (N)
	B	C	E	A		
NTS250-74-700	100		700	700	81.8	17500
NTS250-74-750	150		750	750	87.7	18500
NTS250-74-800	200		800	800	93.5	19500
NTS250-74-850	250		850	850	99.4	20000
NTS250-74-900	300		900	900	105.2	20000
NTS250-74-950	350		950	950	111.0	19700
NTS250-74-1000	400		1000	1000	116.9	19500
NTS250-74-1100		150	1100	1100	128.6	19000
NTS250-74-1200		200	1200	1200	140.3	18500
NTS250-74-1300		250	1300	1300	152.0	18000
NTS250-74-1400		300	1400	1400	163.7	17500
NTS250-74-1500		350	1500	1500	175.4	16900
NTS250-74-1600		400	1600	1600	187.0	16100
NTS250-74-1700		450	1700	1700	198.7	15300
NTS250-74-1800		500	1800	1800	210.4	14500
NTS250-74-1900		550	1900	1900	222.1	13500
NTS250-74-2000		600	2000	2000	233.8	12500

Ordercode and further options see last page. Your desired length is not listed in the table? No problem! Only the most common lengths are shown here. Please contact our application technology division.

HEAVY DUTY EXTENSION

NTS250-104

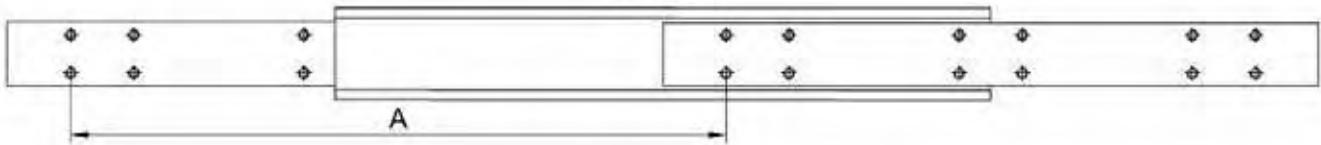
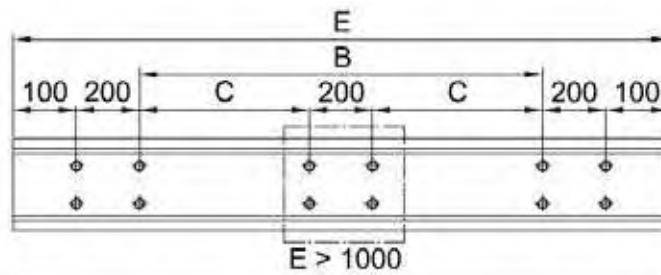
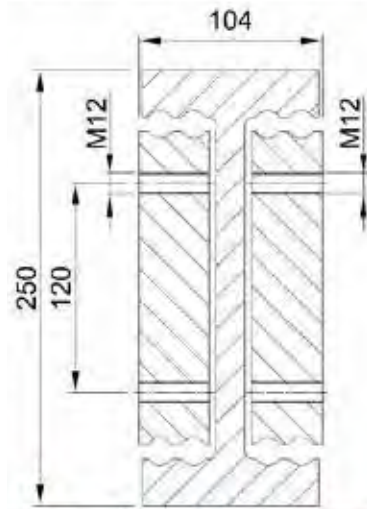

Load Table

Order Number	Hole separation (mm)		Installation length (mm)	Extension length (mm)	Net weight (kg)	Maximum load/pair (N)
	B	C	E	A		
NTS250-104-700	100		700	700	121.8	27000
NTS250-104-750	150		750	750	130.5	28000
NTS250-104-800	200		800	800	139.2	28500
NTS250-104-850	250		850	850	147.9	29000
NTS250-104-900	300		900	900	156.6	29500
NTS250-104-950	350		950	950	165.3	30000
NTS250-104-1000	400		1000	1000	174.0	30000
NTS250-104-1100		150	1100	1100	191.4	29500
NTS250-104-1200		200	1200	1200	208.8	29000
NTS250-104-1300		250	1300	1300	226.2	28500
NTS250-104-1400		300	1400	1400	243.6	28000
NTS250-104-1500		350	1500	1500	261.0	27000
NTS250-104-1600		400	1600	1600	278.4	26000
NTS250-104-1700		450	1700	1700	295.8	25000
NTS250-104-1800		500	1800	1800	313.2	24000
NTS250-104-1900		550	1900	1900	330.6	23000
NTS250-104-2000		600	2000	2000	348.0	22000

Ordercode and further options see last page. Your desired length is not listed in the table? No problem! Only the most common lengths are shown here. Please contact our application technology division.

NOTES

A large grid of graph paper for taking notes, consisting of 20 columns and 30 rows of small squares.



OVER EXTENSIONS



PAGE 76

5.1 PRODUCT OVERVIEW

PAGE 78

5.2 OVER EXTENSIONS

- NTSU40-52DS
- NTU48-35DC
- NTSU50-60DS
- NTU59-41.5DC
- NTSU60-40
- NTSU60-68DS
- NTU72-30T
- NTU72-47.5DC
- NTSU80-43
- NTSU80-79DS
- NTSU100-51
- NTSU100-98DS
- NTSU150-64

PRODUCT OVERVIEW

OVER EXTENSIONS

NTSU40-52DS

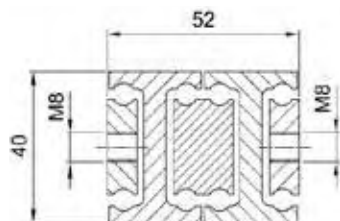

NTU48-35DC

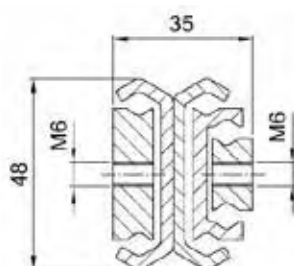

NTSU50-60DS

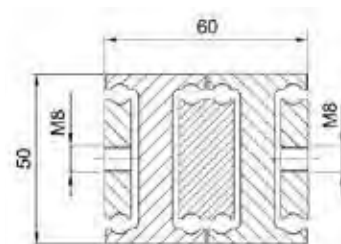

NTU59-41.5DC

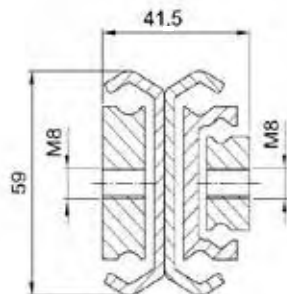

NTSU60-40

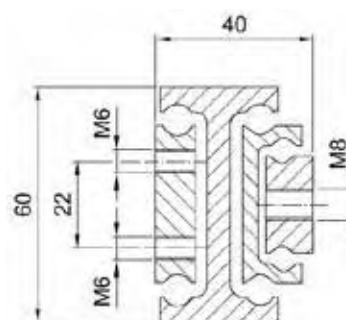

NTSU60-68DS

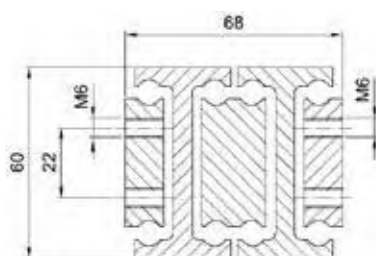

NTU72-30T

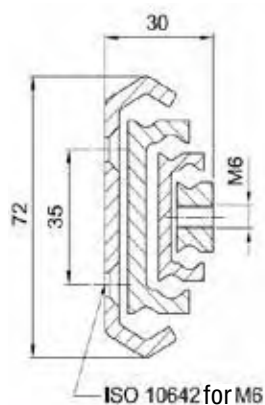

NTU72-47.5DC

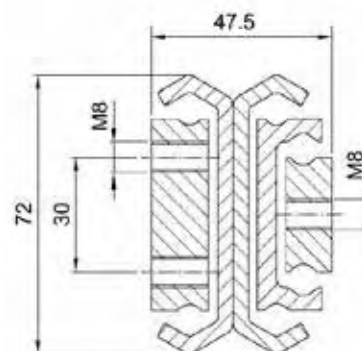

NTSU80-43

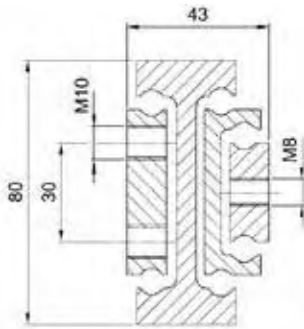

NTSU80-79DS

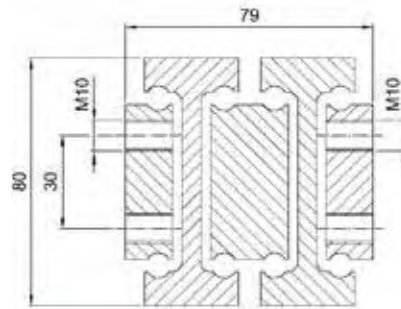

NTSU100-51

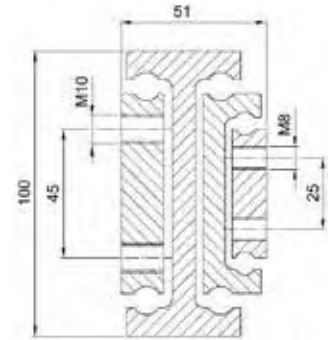

NTSU100-98DS

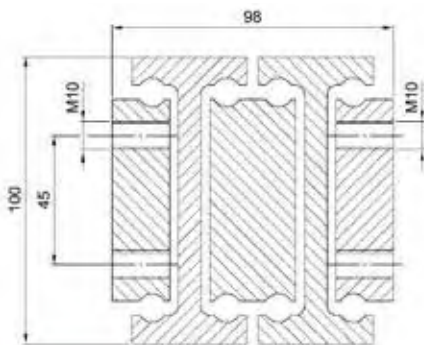

NTSU150-64

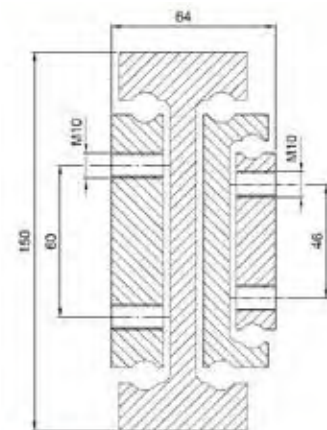

OVER EXTENSION

NTSU40-52DS

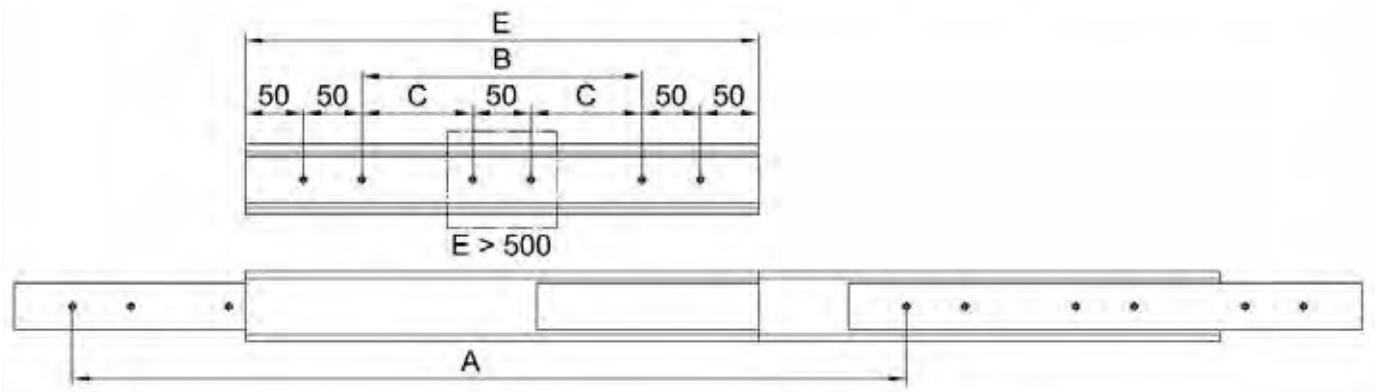
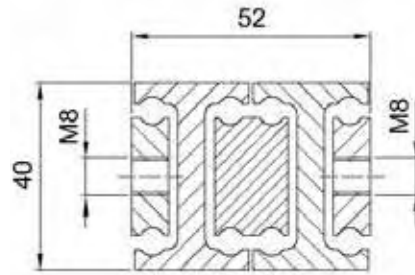

Load Table

Order Number	Hole separation (mm)		Installation length (mm)	Extension length (mm)	Net weight (kg)	Maximum load/pair (N)
	B	C	E	A		
NTSU40-52DS-250	50		250	500	2.0	600
NTSU40-52DS-300	100		300	600	2.5	650
NTSU40-52DS-350	150		350	700	2.9	710
NTSU40-52DS-400	200		400	800	3.3	750
NTSU40-52DS-450	250		450	900	3.7	750
NTSU40-52DS-500	300		500	1000	4.1	750
NTSU40-52DS-550		150	550	1100	4.5	750
NTSU40-52DS-600		175	600	1200	4.9	710
NTSU40-52DS-650		200	650	1300	5.3	710
NTSU40-52DS-700		225	700	1400	5.7	650
NTSU40-52DS-750		250	750	1500	6.1	600
NTSU40-52DS-800		275	800	1600	6.5	550
NTSU40-52DS-850		300	850	1700	7.0	500
NTSU40-52DS-900		325	900	1800	7.4	450
NTSU40-52DS-950		350	950	1900	7.8	380
NTSU40-52DS-1000		375	1000	2000	8.2	350
NTSU40-52DS-1100		425	1100	2200	9.0	320
NTSU40-52DS-1200		475	1200	2400	9.8	300

Ordercode and further options see last page. Your desired length is not listed in the table? No problem! Only the most common lengths are shown here. Please contact our application technology division.

NTU48-35DC

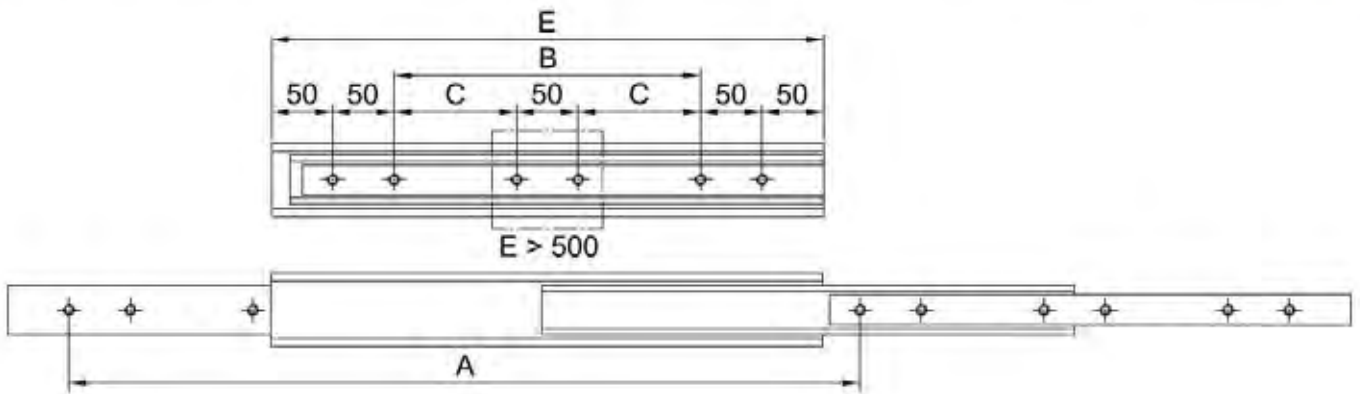
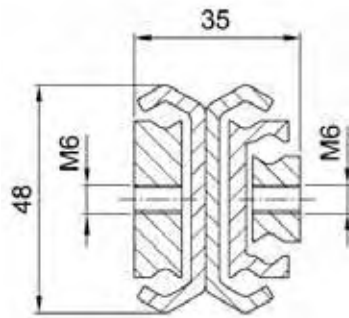

Load Table

Order Number	Hole separation (mm)		Installation length (mm)	Extension length (mm)	Net weight (kg)	Maximum load/pair (N)
	B	C	E	A		
NTU48-35DC-250	50		250	375	2.0	600
NTU48-35DC-300	100		300	450	2.5	650
NTU48-35DC-350	150		350	525	2.9	710
NTU48-35DC-400	200		400	600	3.3	750
NTU48-35DC-450	250		450	675	3.7	750
NTU48-35DC-500	300		500	750	4.1	750
NTU48-35DC-550		150	550	825	4.5	750
NTU48-35DC-600		175	600	900	4.9	710
NTU48-35DC-650		200	650	975	5.3	710
NTU48-35DC-700		225	700	1050	5.7	650
NTU48-35DC-750		250	750	1125	6.1	600
NTU48-35DC-800		275	800	1200	6.5	550
NTU48-35DC-850		300	850	1275	7.0	500
NTU48-35DC-900		325	900	1350	7.4	450
NTU48-35DC-950		350	950	1425	7.8	380
NTU48-35DC-1000		375	1000	1500	8.2	350
NTU48-35DC-1100		425	1100	1675	9.0	320
NTU48-35DC-1200		475	1200	1750	9.8	300

Ordercode and further options see last page. Your desired length is not listed in the table? No problem! Only the most common lengths are shown here. Please contact our application technology division.

OVER EXTENSION

NTSU50-60DS

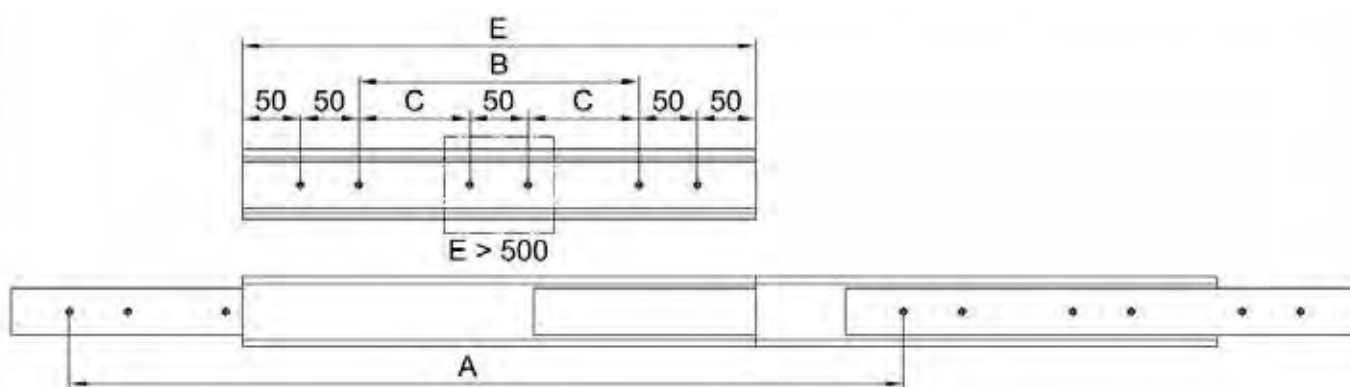
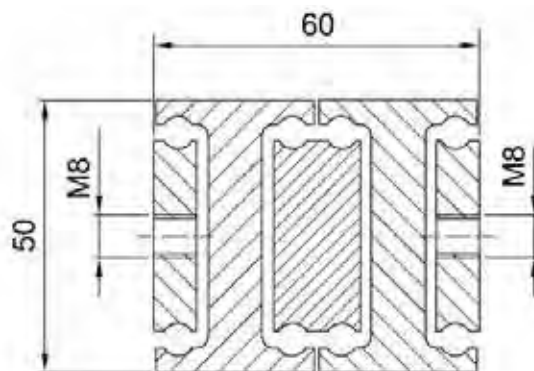

Load Table

Order Number	Hole separation (mm)		Installation length (mm)	Extension length (mm)	Net weight (kg)	Maximum load/pair (N)
	B	C	E	A		
NTSU50-60DS-300	100		300	600	3,3	1800
NTSU50-60DS-350	150		350	700	3,8	1900
NTSU50-60DS-400	200		400	800	4,4	1950
NTSU50-60DS-450	250		450	900	4,9	2000
NTSU50-60DS-500	300		500	1000	5,5	2000
NTSU50-60DS-550		150	550	1100	6,0	1950
NTSU50-60DS-600		175	600	1200	6,6	1900
NTSU50-60DS-650		200	650	1300	7,1	1850
NTSU50-60DS-700		225	700	1400	7,7	1800
NTSU50-60DS-750		250	750	1500	8,2	1750
NTSU50-60DS-800		275	800	1600	8,8	1700
NTSU50-60DS-850		300	850	1700	9,3	1630
NTSU50-60DS-900		325	900	1800	9,9	1560
NTSU50-60DS-950		350	950	1900	10,4	1490
NTSU50-60DS-1000		375	1000	2000	11,0	1420
NTSU50-60DS-1100		425	1100	2200	12,1	1290
NTSU50-60DS-1200		475	1200	2400	13,2	1160
NTSU50-60DS-1300		525	1300	2600	14,3	1020
NTSU50-60DS-1400		575	1400	2800	15,4	860
NTSU50-60DS-1500		625	1500	3000	16,5	700

Ordercode and further options see last page. Your desired length is not listed in the table? No problem! Only the most common lengths are shown here. Please contact our application technology division.

NTU59-41.5DC

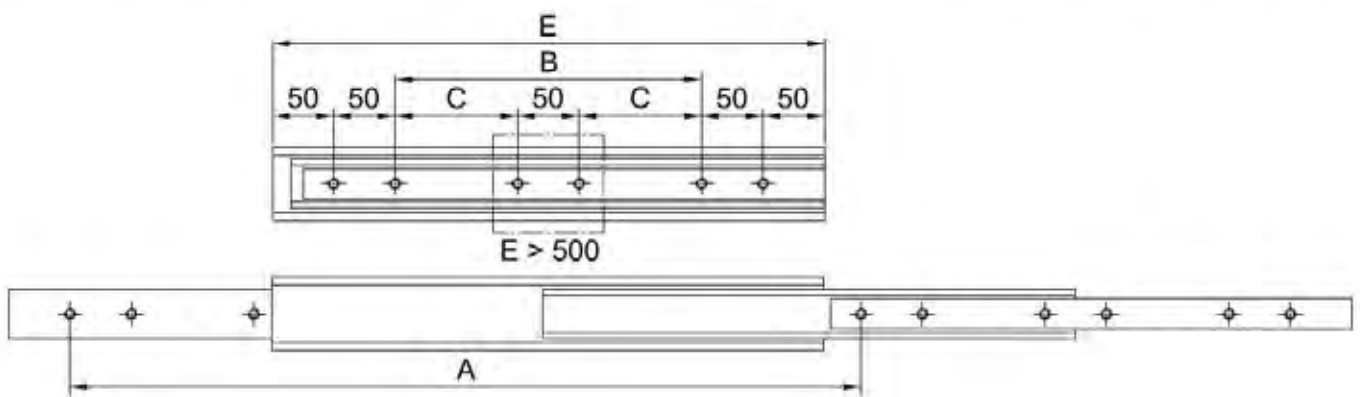
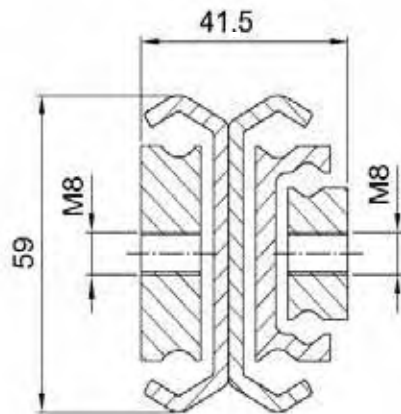

Load Table

Order Number	Hole separation (mm)		Installation length (mm)	Extension length (mm)	Net weight (kg)	Maximum load/pair (N)
	B	C	E	A		
NTU59-41.5DC-300	100		300	450	3.3	1800
NTU59-41.5DC-350	150		350	525	3.8	1900
NTU59-41.5DC-400	200		400	600	4.4	1950
NTU59-41.5DC-450	250		450	675	4.9	2000
NTU59-41.5DC-500	300		500	750	5.5	2000
NTU59-41.5DC-550		150	550	825	6.0	1950
NTU59-41.5DC-600		175	600	900	6.6	1900
NTU59-41.5DC-650		200	650	975	7.1	1850
NTU59-41.5DC-700		225	700	1050	7.7	1800
NTU59-41.5DC-750		250	750	1125	8.2	1750
NTU59-41.5DC-800		275	800	1200	8.8	1700
NTU59-41.5DC-850		300	850	1275	9.3	1630
NTU59-41.5DC-900		325	900	1350	9.9	1560
NTU59-41.5DC-950		350	950	1425	10.4	1490
NTU59-41.5DC-1000		375	1000	1500	11.0	1420
NTU59-41.5DC-1100		425	1100	1650	12.1	1290
NTU59-41.5DC-1200		475	1200	1800	13.2	1160
NTU59-41.5DC-1300		525	1300	1950	14.3	1020
NTU59-41.5DC-1400		575	1400	2100	15.4	860

Ordercode and further options see last page. Your desired length is not listed in the table? No problem! Only the most common lengths are shown here. Please contact our application technology division.

OVER EXTENSION

NTSU60-40

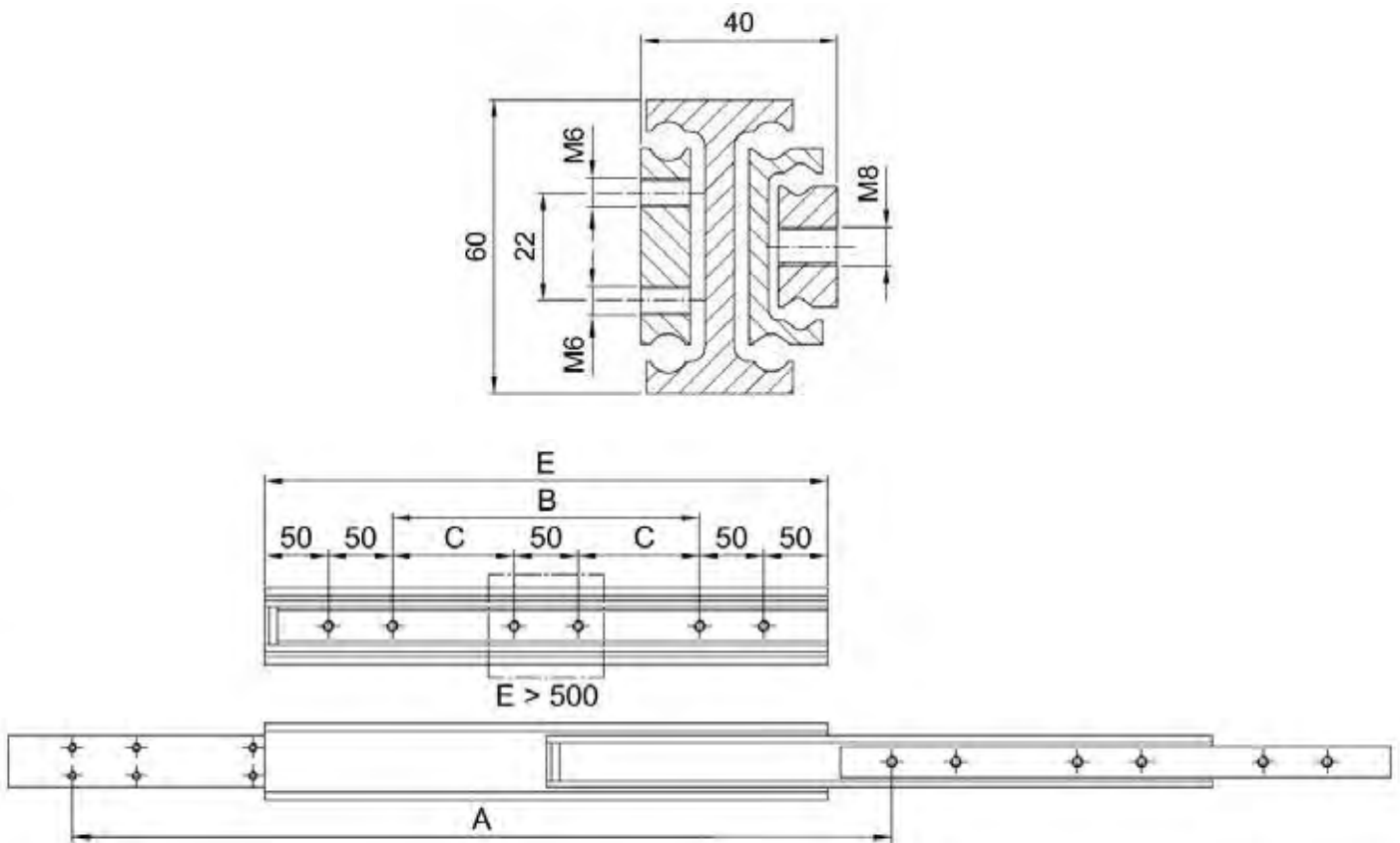

Load Table

Order Number	Hole separation (mm)		Installation length (mm)	Extension length (mm)	Net weight (kg)	Maximum load/pair (N)
	B	C	E	A		
NTSU60-40-300	100		300	450	4.1	2500
NTSU60-40-350	150		350	525	4.7	2600
NTSU60-40-400	200		400	600	5.3	2650
NTSU60-40-450	250		450	675	6.0	2700
NTSU60-40-500	300		500	750	6.6	2700
NTSU60-40-550		150	550	825	7.3	1650
NTSU60-40-600		175	600	900	7.9	2600
NTSU60-40-650		200	650	975	8.6	2550
NTSU60-40-700		225	700	1050	9.2	2500
NTSU60-40-750		250	750	1125	9.9	2450
NTSU60-40-800		275	800	1200	10.5	2400
NTSU60-40-850		300	850	1275	11.1	2350
NTSU60-40-900		325	900	1350	11.8	2300
NTSU60-40-950		350	950	1425	12.4	2250
NTSU60-40-1000		375	1000	1500	13.1	2200
NTSU60-40-1100		425	1100	1650	14.3	2100
NTSU60-40-1200		475	1200	1800	15.6	1950
NTSU60-40-1300		525	1300	1950	16.9	1800
NTSU60-40-1400		575	1400	2100	18.2	1650
NTSU60-40-1500		625	1500	2250	19.5	1500

Ordercode and further options see last page. Your desired length is not listed in the table? No problem! Only the most common lengths are shown here. Please contact our application technology division.

NTSU60-68DS

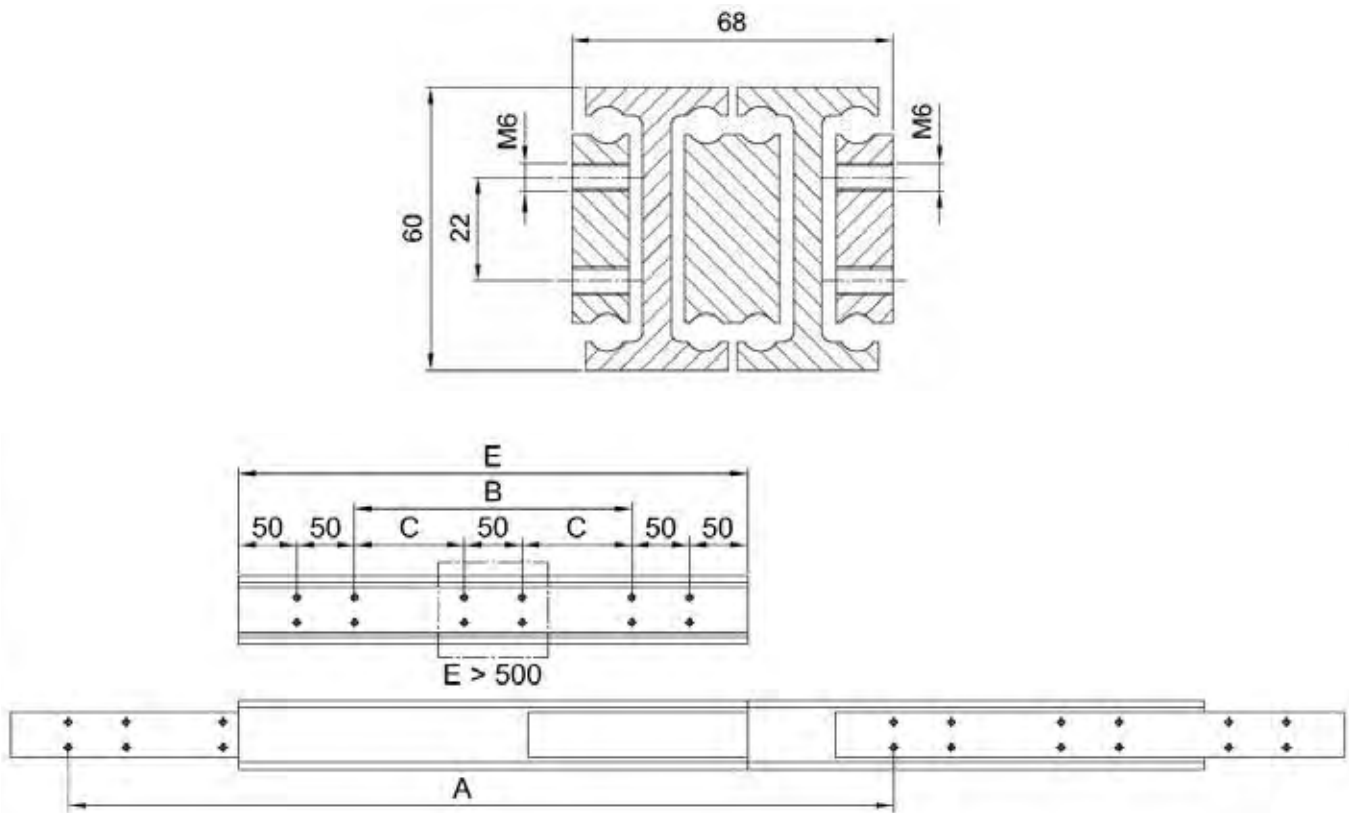

Load Table

Order Number	Hole separation (mm)		Installation length (mm)	Extension length (mm)	Net weight (kg)	Maximum load/pair (N)
	B	C	E	A		
NTSU60-68DS-500	300		500	1000	11.5	7120
NTSU60-68DS-550		150	550	1100	12.6	7250
NTSU60-68DS-600		175	600	1200	13.8	7120
NTSU60-68DS-650		200	650	1300	14.9	7050
NTSU60-68DS-700		225	700	1400	16.0	7050
NTSU60-68DS-750		250	750	1500	17.1	6730
NTSU60-68DS-800		275	800	1600	18.2	6470
NTSU60-68DS-850		300	850	1700	19.4	6210
NTSU60-68DS-900		325	900	1800	20.5	5950
NTSU60-68DS-950		350	950	1900	21.7	5690
NTSU60-68DS-1000		375	1000	2000	22.8	5360
NTSU60-68DS-1100		425	1100	2200	25.0	4910
NTSU60-68DS-1200		475	1200	2400	27.3	4390
NTSU60-68DS-1300		525	1300	2600	29.6	3870
NTSU60-68DS-1400		576	1400	2800	31.8	3550
NTSU60-68DS-1500		625	1500	3000	34.1	2830

Ordercode and further options see last page. Your desired length is not listed in the table? No problem! Only the most common lengths are shown here. Please contact our application technology division.

OVER EXTENSION

NTU72-30T

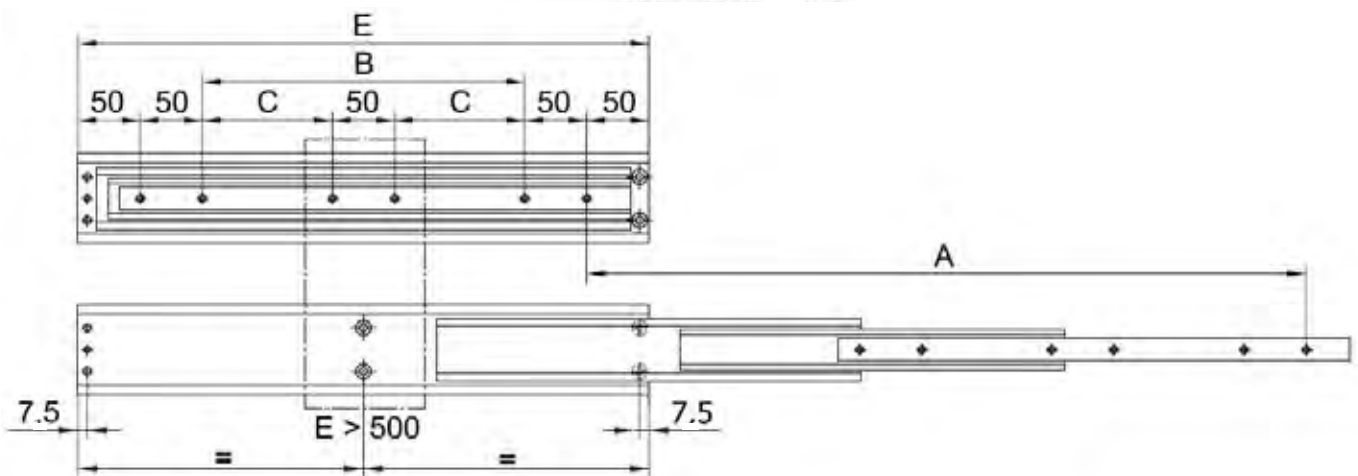
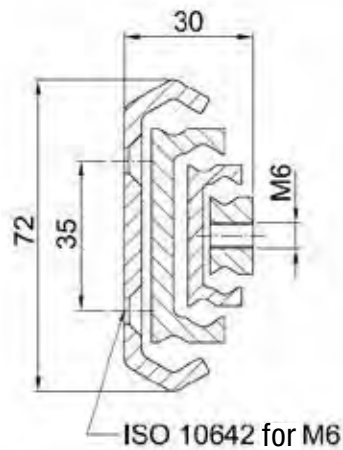

Load Table

Order Number	Hole separation (mm)		Installation length (mm)	Extension length (mm)	Net weight (kg)	Maximum load/pair (N)
	B	C				
NTU72-30T-300	100		300	450	2.6	1380
NTU72-30T-350	150		350	525	3.0	1440
NTU72-30T-400	200		400	600	3.4	1500
NTU72-30T-450	250		450	675	3.9	1550
NTU72-30T-500	300		500	750	4.3	1500
NTU72-30T-550		150	550	825	4.7	1380
NTU72-30T-600		175	600	900	5.2	1320
NTU72-30T-650		200	650	975	5.6	1260
NTU72-30T-700		225	700	1050	6.0	1210
NTU72-30T-750		250	750	1125	6.4	1150
NTU72-30T-800		275	800	1200	6.9	1090
NTU72-30T-850		300	850	1275	7.3	1030
NTU72-30T-900		325	900	1350	7.7	980
NTU72-30T-950		350	950	1425	8.2	920
NTU72-30T-1000		375	1000	1500	8.6	860
NTU72-30T-1100		425	1100	1650	9.5	750
NTU72-30T-1200		475	1200	1800	10.3	630
NTU72-30T-1300		525	1300	1950	11.2	520
NTU72-30T-1400		575	1400	2100	12.0	400
NTU72-30T-1500		625	1500	2250	12.9	300

Ordercode and further options see last page. Your desired length is not listed in the table? No problem! Only the most common lengths are shown here. Please contact our application technology division.

NTU72-47.5DC

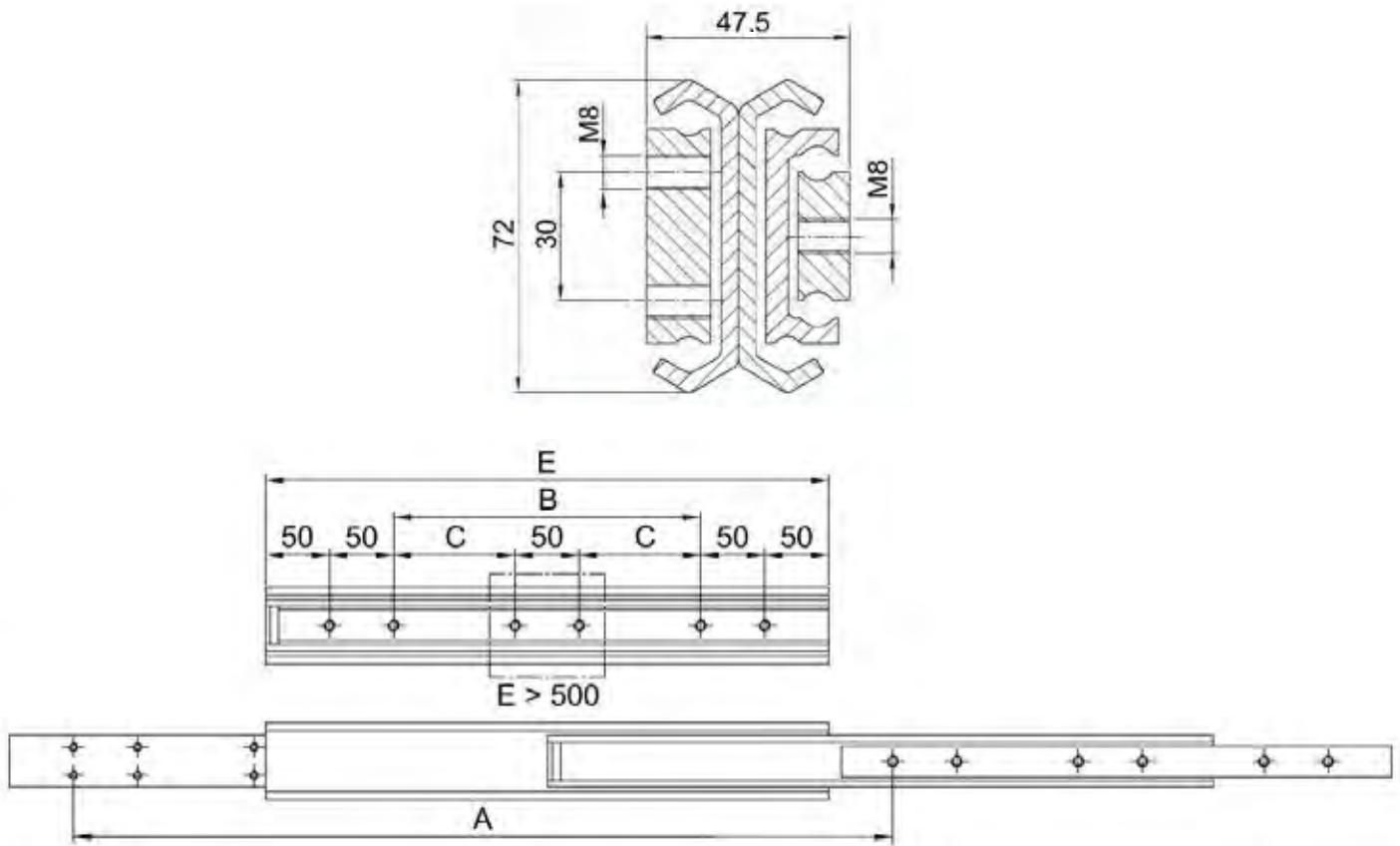

Load Table

Order Number	Hole separation (mm)		Installation length (mm)	Extension length (mm)	Net weight (kg)	Maximum load/pair (N)
	B	C	E	A		
NTU72-47.5DC-300	100		300	450	5.1	2500
NTU72-47.5DC-350	150		350	525	5.9	2600
NTU72-47.5DC-400	200		400	600	6.8	2650
NTU72-47.5DC-450	250		450	675	7.6	2700
NTU72-47.5DC-500	300		500	750	8.5	2700
NTU72-47.5DC-550		150	550	825	9.3	2650
NTU72-47.5DC-600		175	600	900	10.2	2600
NTU72-47.5DC-650		200	650	975	11.0	2550
NTU72-47.5DC-700		225	700	1050	11.9	2500
NTU72-47.5DC-750		250	750	1125	12.7	2450
NTU72-47.5DC-800		275	800	1200	13.6	2400
NTU72-47.5DC-850		300	850	1275	14.4	2350
NTU72-47.5DC-900		325	900	1350	15.3	2300
NTU72-47.5DC-950		350	950	1425	16.1	2250
NTU72-47.5DC-1000		375	1000	1500	17.0	2200
NTU72-47.5DC-1100		425	1100	1650	18.7	2100
NTU72-47.5DC-1200		475	1200	1800	20.4	1950
NTU72-47.5DC-1300		525	1300	1950	22.1	1800
NTU72-47.5DC-1400		575	1400	2100	23.8	1650
NTU72-47.5DC-1500		625	1500	2250	25.5	1500

Ordercode and further options see last page. Your desired length is not listed in the table? No problem! Only the most common lengths are shown here. Please contact our application technology division.

OVER EXTENSION

NTSU80-43

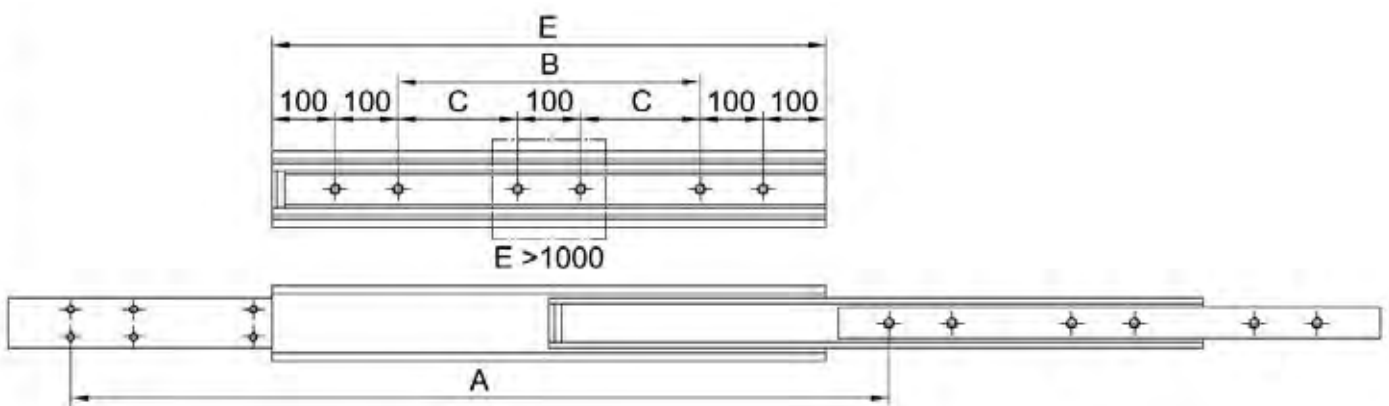
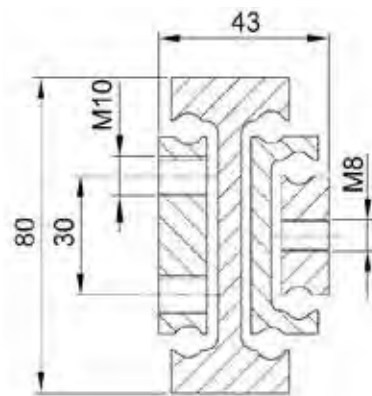

Order Number	Load Table					
	Hole separation (mm)		Installation length (mm)	Extension length (mm)	Net weight (kg)	Maximum load/pair (N)
	B	C	E	A		
NTSU80-43-500	100		500	750	9.5	3200
NTSU80-43-550	150		550	825	10.4	3250
NTSU80-43-600	200		600	900	11.4	3300
NTSU80-43-650	250		650	975	12.3	3250
NTSU80-43-700	300		700	1050	13.3	3200
NTSU80-43-750	350		750	1125	14.2	3100
NTSU80-43-800	400		800	1200	15.1	3000
NTSU80-43-850	450		850	1275	15.9	2900
NTSU80-43-900	500		900	1350	17.0	2800
NTSU80-43-950	550		950	1425	17.9	2700
NTSU80-43-1000	600		1000	1500	18.8	2600
NTSU80-43-1100		300	1100	1650	20.7	2380
NTSU80-43-1200		350	1200	1800	22.5	2160
NTSU80-43-1300		400	1300	1950	24.4	1940
NTSU80-43-1400		450	1400	2100	26.2	1720
NTSU80-43-1500		500	1500	2250	28.1	1500

Ordercode and further options see last page. Your desired length is not listed in the table? No problem! Only the most common lengths are shown here. Please contact our application technology division.

NTSU80-79DS

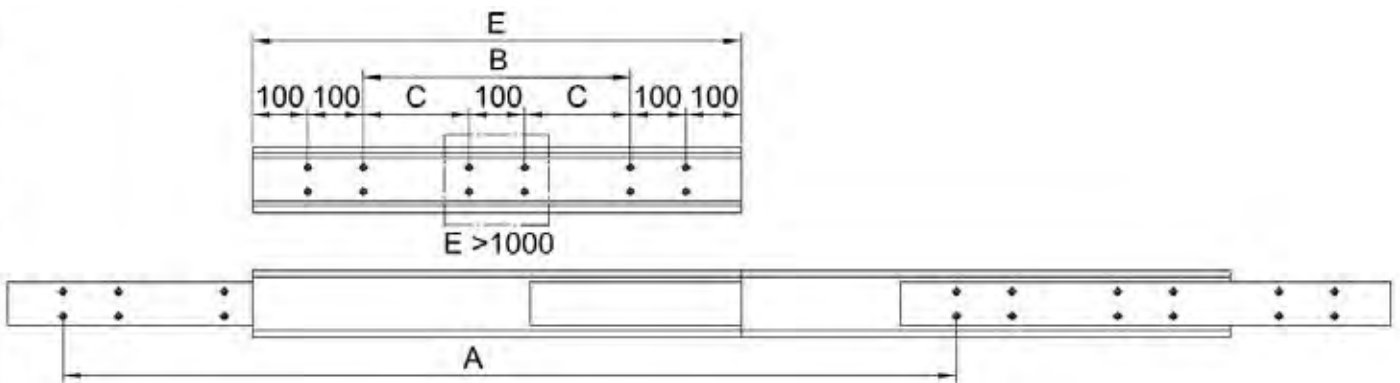
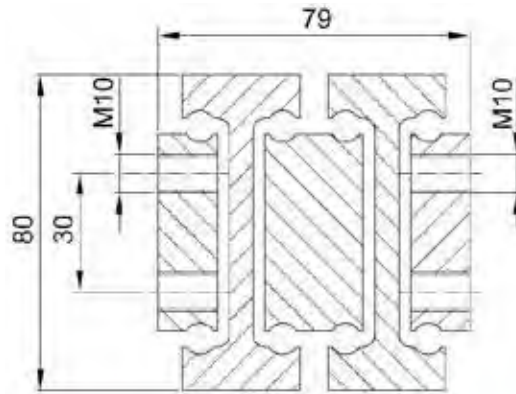

Load Table

Order Number	Hole separation (mm)		Installation length (mm)	Extension length (mm)	Net weight (kg)	Maximum load/pair (N)
	B	C	E	A		
NTSU80-79DS-500	100		500	1000	17.6	10900
NTSU80-79DS-550	150		550	1100	19.3	11200
NTSU80-79DS-600	200		600	1200	21.1	11320
NTSU80-79DS-650	250		650	1300	22.8	11140
NTSU80-79DS-700	300		700	1400	24.8	10960
NTSU80-79DS-750	350		750	1500	26.3	10660
NTSU80-79DS-800	400		800	1600	28.0	10420
NTSU80-79DS-850	450		850	1700	29.8	10120
NTSU80-79DS-900	500		900	1800	31.5	9820
NTSU80-79DS-950	550		950	1900	33.3	9520
NTSU80-79DS-1000	600		1000	2000	35.0	9280
NTSU80-79DS-1100		300	1100	2200	38.5	8680
NTSU80-79DS-1200		350	1200	2400	42.0	8140
NTSU80-79DS-1300		400	1300	2600	45.4	7540
NTSU80-79DS-1400		450	1400	2800	48.9	6940
NTSU80-79DS-1500		500	1500	3000	52.4	6340

Ordercode and further options see last page. Your desired length is not listed in the table? No problem! Only the most common lengths are shown here. Please contact our application technology division.

OVER EXTENSION

NTSU100-51

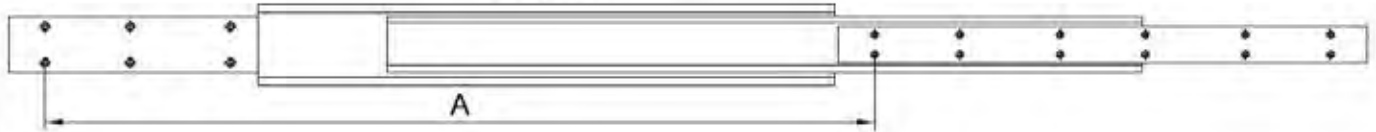
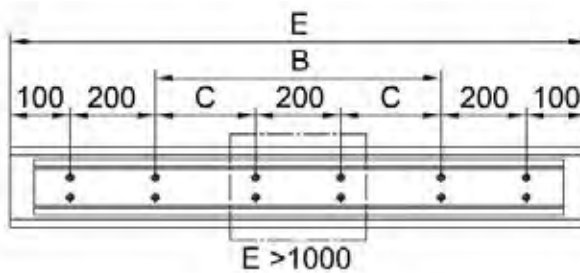
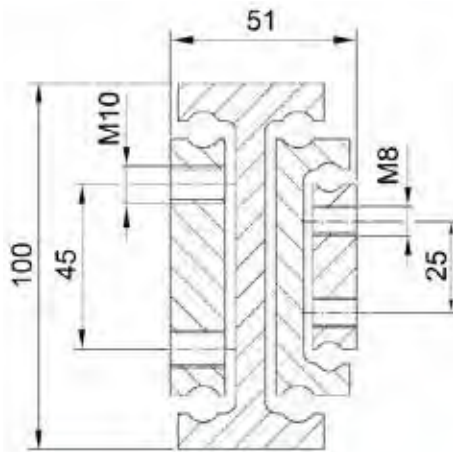

Load Table

Order Number	Hole separation (mm)		Installation length (mm)	Extension length (mm)	Net weight (kg)	Maximum load/pair (N)
	B	C	E	A		
NTSU100-51-700	100		700	1050	20.2	5600
NTSU100-51-750	150		750	1125	21.7	5600
NTSU100-51-800	200		800	1200	23.1	5400
NTSU100-51-850	250		850	1275	24.5	5200
NTSU100-51-900	300		900	1350	26.0	4800
NTSU100-51-950	350		950	1425	27.4	4600
NTSU100-51-1000	400		1000	1500	28.8	4400
NTSU100-51-1100		150	1100	1650	31.7	4100
NTSU100-51-1200		200	1200	1800	34.6	3800
NTSU100-51-1300		250	1300	1950	37.5	3500
NTSU100-51-1400		300	1400	2100	40.3	3200
NTSU100-51-1500		350	1500	2250	43.2	3000
NTSU100-51-1600		400	1600	2400	45.0	2700
NTSU100-51-1700		450	1700	2550	48.9	2400
NTSU100-51-1800		500	1800	2700	51.8	2100
NTSU100-51-1900		550	1900	2850	54.7	1800
NTSU100-51-2000		600	2000	3000	57.5	1500

Ordercode and further options see last page. Your desired length is not listed in the table? No problem! Only the most common lengths are shown here. Please contact our application technology division.

NTSU100-98DS

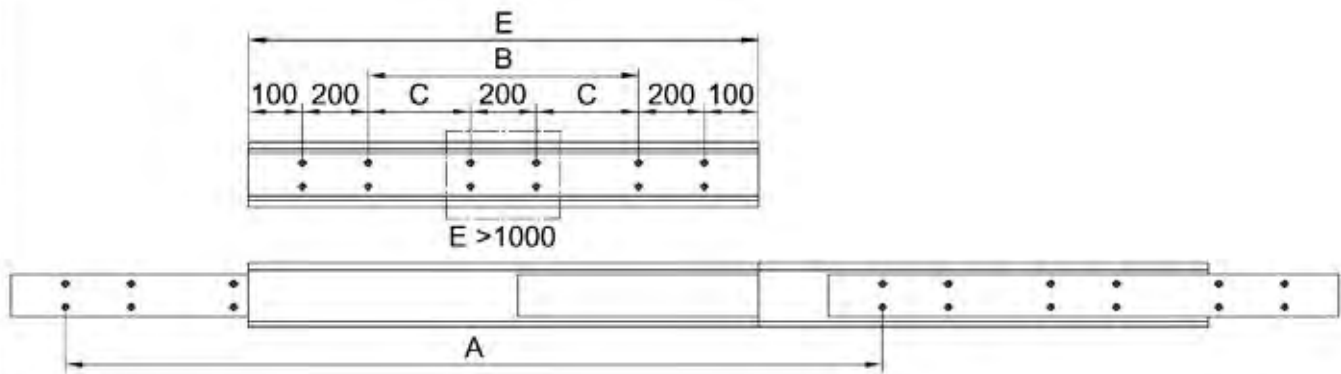
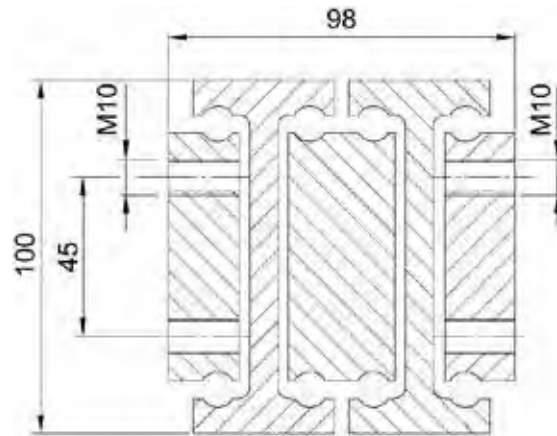

Load Table

Order Number	Hole separation (mm)		Installation length (mm)	Extension length (mm)	Net weight (kg)	Maximum load/pair (N)
	B	C	E	A		
NTSU100-98DS-650	50		650	1300	39.1	13925
NTSU100-98DS-700	100		700	1400	42.1	13700
NTSU100-98DS-750	150		750	1500	45.1	13325
NTSU100-98DS-800	200		800	1600	48.2	13025
NTSU100-98DS-850	250		850	1700	51.2	12650
NTSU100-98DS-900	300		900	1800	54.2	12275
NTSU100-98DS-950	350		950	1900	57.2	11900
NTSU100-98DS-1000	400		1000	2000	60.2	11600
NTSU100-98DS-1100		150	1100	2200	66.2	10850
NTSU100-98DS-1200		200	1200	2400	72.2	10175
NTSU100-98DS-1300		250	1300	2600	78.3	9425
NTSU100-98DS-1400		300	1400	2800	84.3	8675
NTSU100-98DS-1500		350	1500	3000	90.3	7925

Ordercode and further options see last page. Your desired length is not listed in the table? No problem! Only the most common lengths are shown here. Please contact our application technology division.

OVER EXTENSION

NTSU150-64

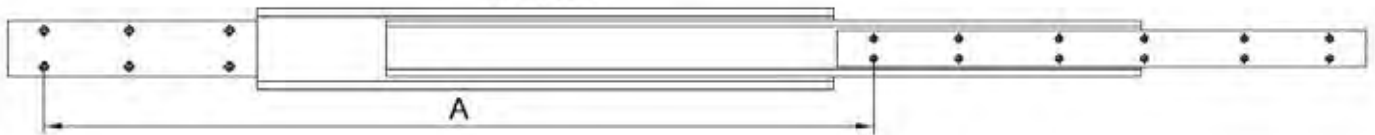
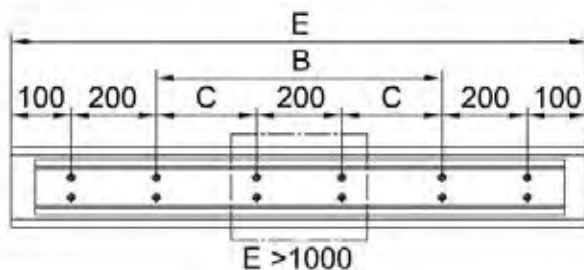
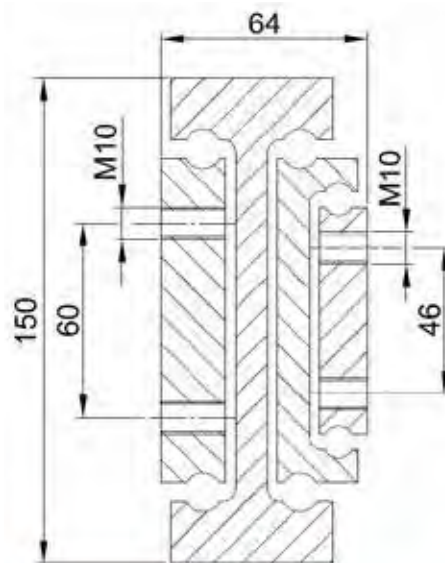

Load Table

Order Number	Hole separation (mm)		Installation length (mm)	Extension length (mm)	Net weight (kg)	Maximum load/pair (N)
	B	C	E	A		
NTSU150-64-700	100		700	1050	38.1	7100
NTSU150-64-750	150		750	1125	40.8	7200
NTSU150-64-800	200		800	1200	43.5	7600
NTSU150-64-850	250		850	1275	46.2	7500
NTSU150-64-900	300		900	1350	48.9	7350
NTSU150-64-950	350		950	1425	51.6	7200
NTSU150-64-1000	400		1000	1500	54.3	7000
NTSU150-64-1100		150	1100	1650	59.7	6600
NTSU150-64-1200		200	1200	1800	65.2	6200
NTSU150-64-1300		250	1300	1950	70.5	5800
NTSU150-64-1400		300	1400	2100	75.9	5300
NTSU150-64-1500		350	1500	2250	81.3	4800
NTSU150-64-1600		400	1600	2400	86.8	4300
NTSU150-64-1700		450	1700	2550	92.2	3800
NTSU150-64-1800		500	1800	2700	97.6	3300
NTSU150-64-1900		550	1900	2850	103.0	2800
NTSU150-64-2000		600	2000	3000	108.5	2400

Ordercode and further options see last page. Your desired length is not listed in the table? No problem! Only the most common lengths are shown here. Please contact our application technology division.

NOTES

A large grid of graph paper for taking notes, consisting of 20 columns and 30 rows of small squares.



LINEAR GUIDES

6

PAGE 94

6.1 PRODUCT OVERVIEW

PAGE 96

6.2 LINEAR GUIDES

- NTSF33
- NTSF40
- NTSF50
- NTSF60
- NTSF80
- NTSF100
- NTSF120

PRODUCT OVERVIEW

LINEAR GUIDES

NTSF33

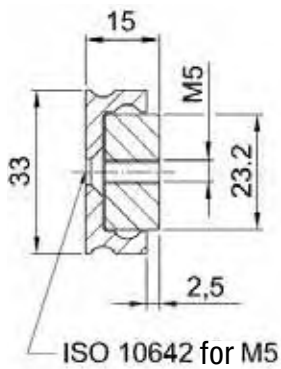

NTSF40

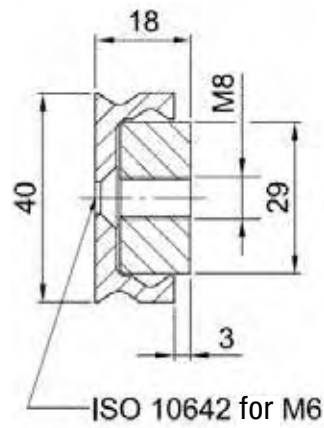

NTSF50

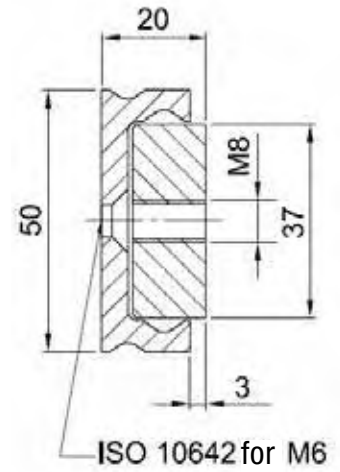

NTSF60

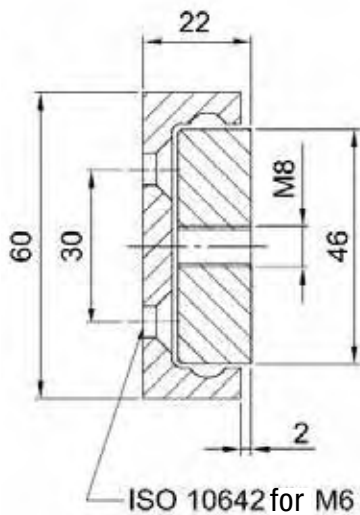

NTSF80

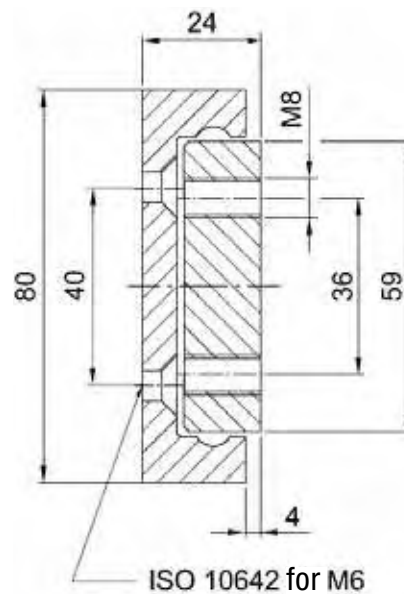

LINEAR GUIDES

NTSF100

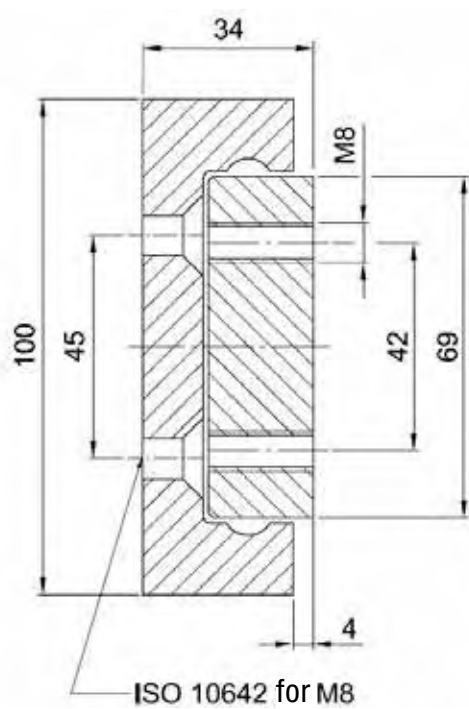

NTSF120

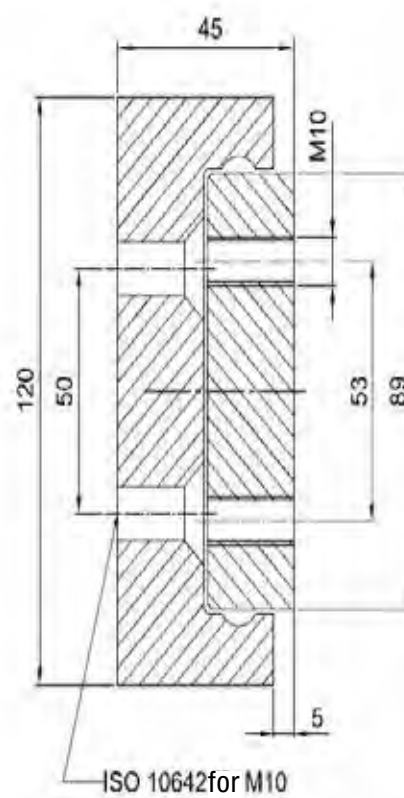

LINEAR GUIDES

NTSF33

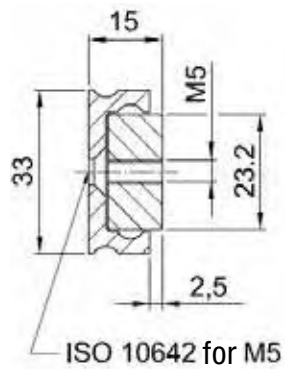

Steel thick-layer passivated

	NTSF33-60	NTSF33-80	NTSF33-100
L (mm)	60	80	100
X (mm)	44	64	84
Stroke	E-80	E-100	E-120
Load / carrier on major axis (N)	1100	1400	1600
Load / carrier on minor axis (N)	550	700	800
Mounting holes slide	2 x M5	2 x M5	2 x M5
Mounting hole guide rail	ISO 10642 for M5		

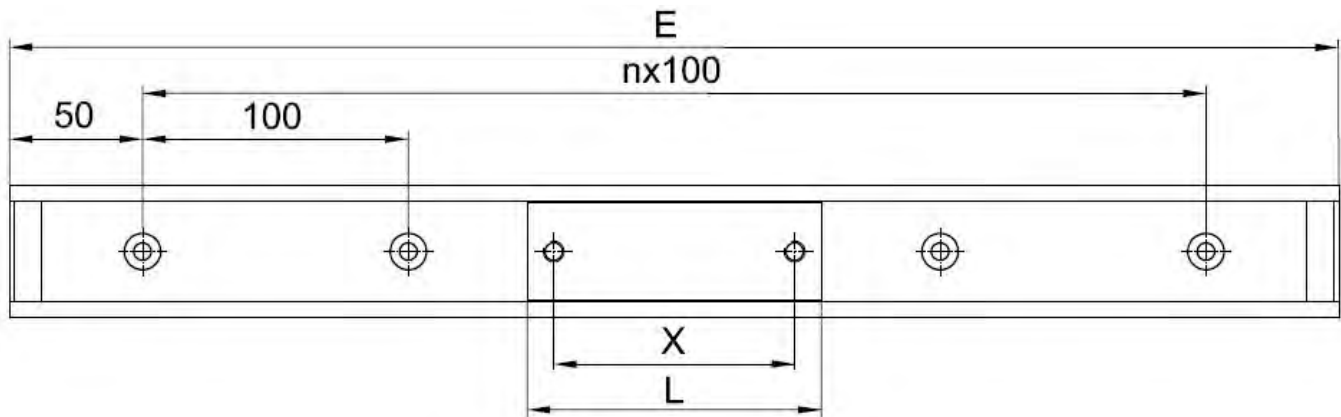

Ordercode and further options see last page. Your desired length is not listed in the table? No problem! Only the most common lengths are shown here. Please contact our application technology division.

NTSF40

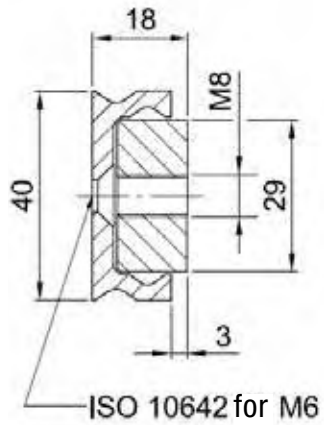

Steel thick-layer passivated

	NTSF40-80	NTSF40-100	NTSF40-120
L (mm)	80	100	120
X (mm)	60	80	100
Stroke	E-104	E-124	E-144
Load / carrier on major axis (N)	1900	2200	2400
Load / carrier on minor axis (N)	950	1100	1200
Mounting holes slide	2 x M8	2 x M8	3 x M8
Mounting hole guide rail	ISO 10642 for M6		

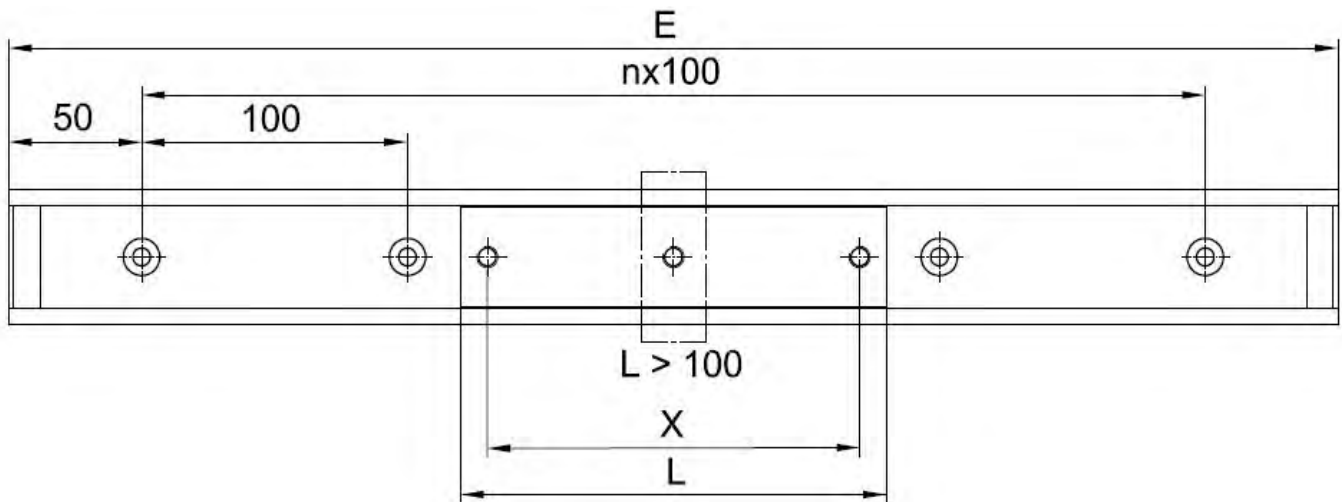

Ordercode and further options see last page. Your desired length is not listed in the table? No problem! Only the most common lengths are shown here. Please contact our application technology division.

LINEAR GUIDES

NTSF50

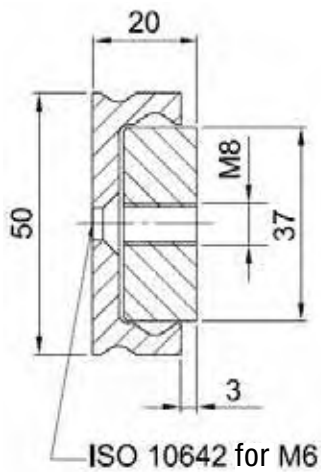

Steel thick-layer passivated

	NTSF50-100	NTSF50-120	NTSF50-160	NTSF50-200
L (mm)	100	120	160	200
X (mm)	80	100	140	180
Stroke	E-124	E-144	E-184	E-224
Load / carrier on major axis (N)	2500	2700	2900	3200
Load / carrier on minor axis (N)	1250	1350	1450	1600
Mounting holes slide	2 x M8	2 x M8	3 x M8	3 x M8
Mounting hole guide rail	ISO 10642 for M6			

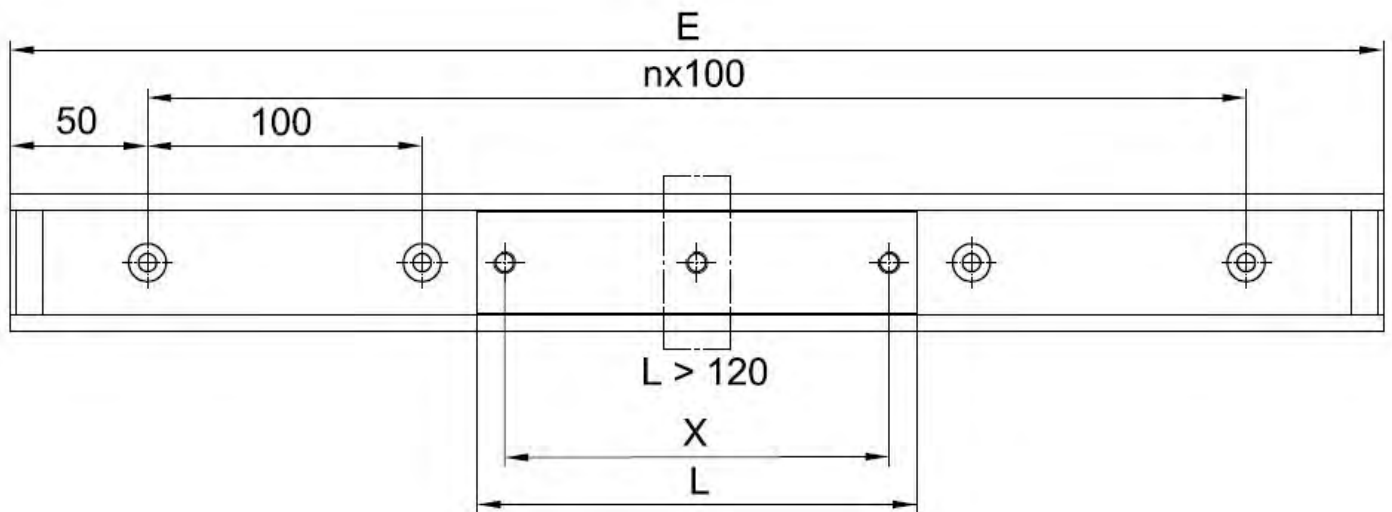

Ordercode and further options see last page. Your desired length is not listed in the table? No problem! Only the most common lengths are shown here. Please contact our application technology division.

NTSF60

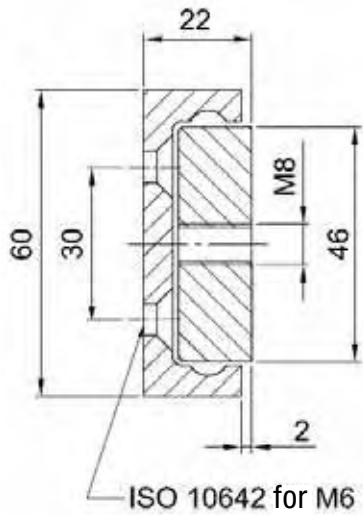

Steel thick-layer passivated

	NTSF60-100	NTSF60-120	NTSF60-160	NTSF60-200
L (mm)	100	120	160	200
X (mm)	80	100	140	180
Stroke	E-130	E-150	E-190	E-230
Load / carrier on major axis (N)	3000	3200	3400	3600
Load / carrier on minor axis (N)	1500	1600	1700	1800
Mounting holes slide	2 x M8	2 x M8	3 x M8	3 x M8
Mounting hole guide rail	ISO 10642 for M6			

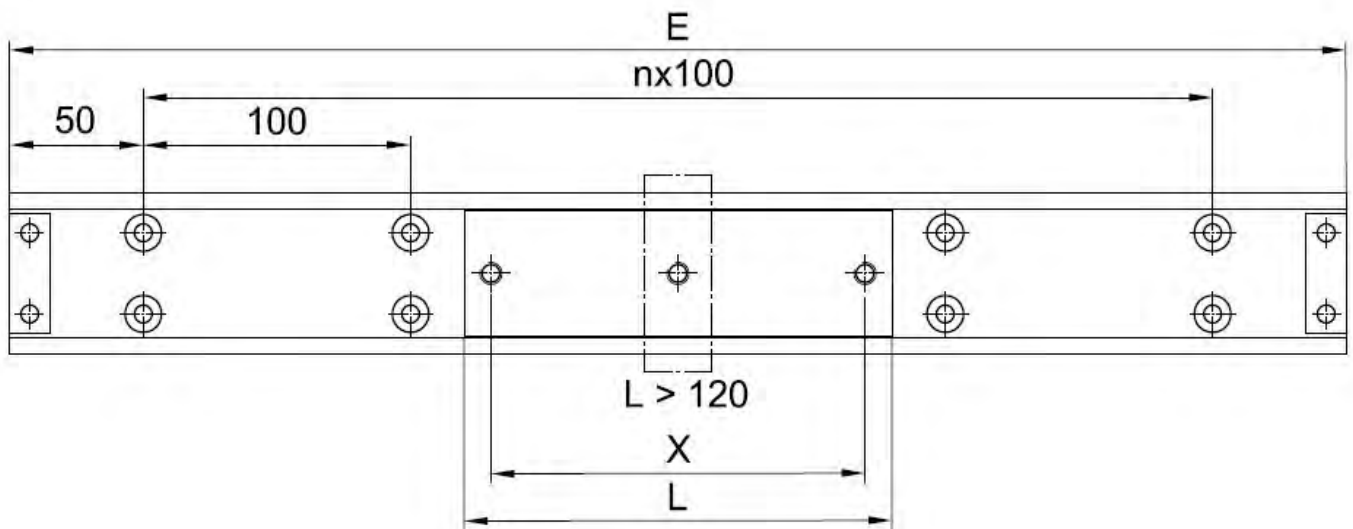

Ordercode and further options see last page. Your desired length is not listed in the table? No problem! Only the most common lengths are shown here. Please contact our application technology division.

LINEAR GUIDES

NTSF80

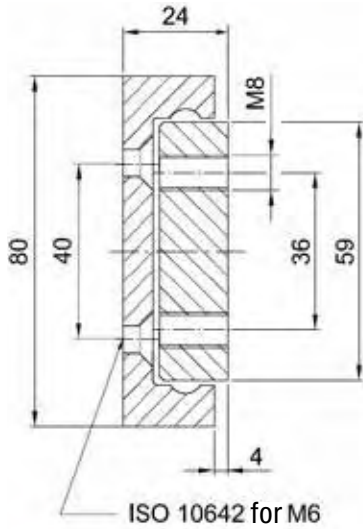

Steel thick-layer passivated

	NTSF80-160	NTSF80-200	NTSF80-300
L (mm)	160	200	300
X (mm)	100	140	240
Stroke	E-190	E-230	E-330
Load / carrier on major axis (N)	5000	5300	6200
Load / carrier on minor axis (N)	2500	2650	3100
Mounting holes slide	4 x M8	5 x M8	5 x M8
Mounting hole guide rail	ISO 10642 for M6		

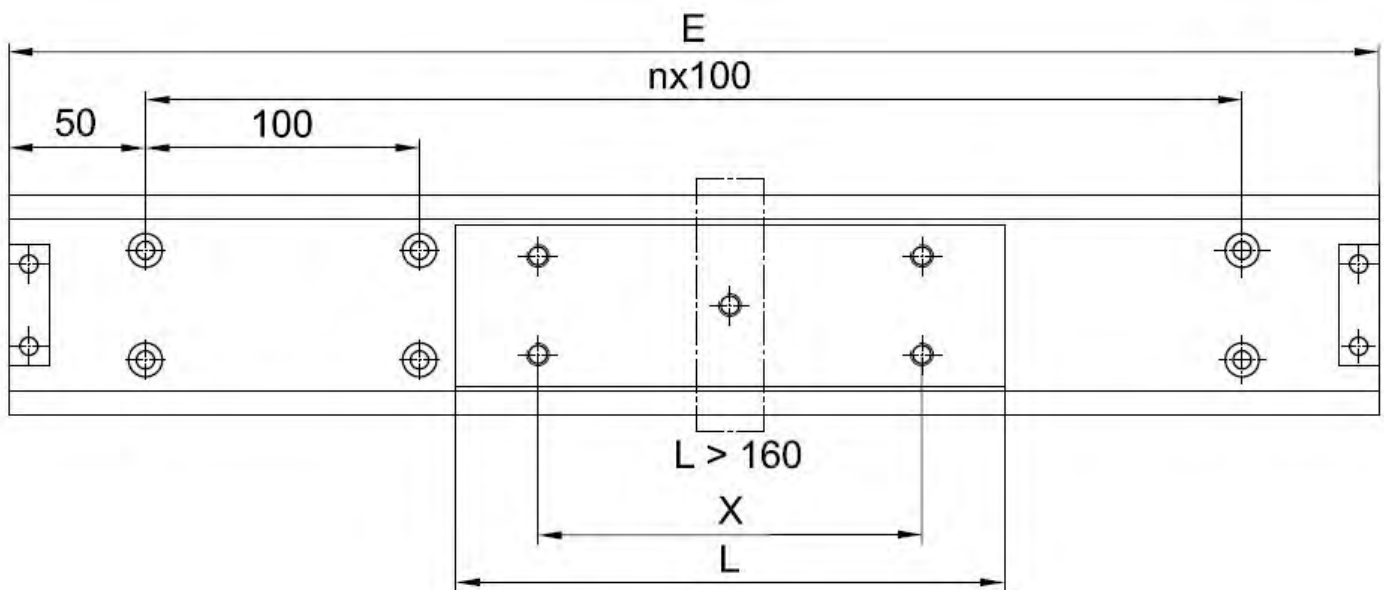

Ordercode and further options see last page. Your desired length is not listed in the table? No problem! Only the most common lengths are shown here. Please contact our application technology division.

NTSF100

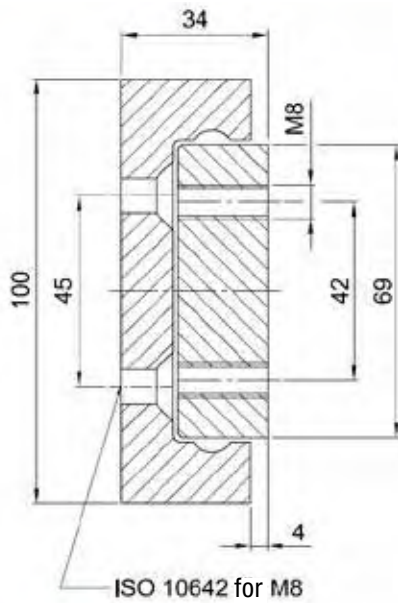

Steel thick-layer passivated

	NTSF100-160	NTSF100-200	NTSF100-300
L (mm)	160	200	300
X (mm)	90	130	230
Stroke	E-200	E-240	E-340
Load / carrier on major axis (N)	6600	7300	8300
Load / carrier on minor axis (N)	3300	3650	4150
Mounting holes slide	4 x M8	4 x M8	5 x M8
Mounting hole guide rail	ISO 10642 for M8		

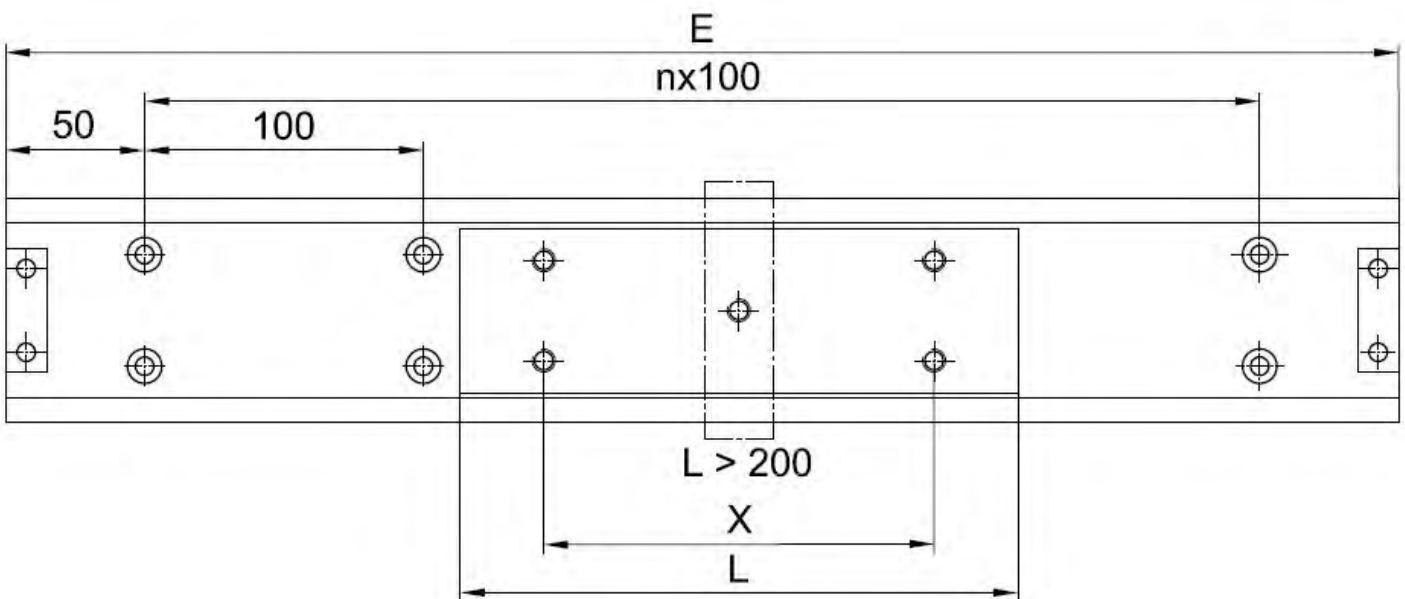

Ordercode and further options see last page. Your desired length is not listed in the table? No problem! Only the most common lengths are shown here. Please contact our application technology division.

LINEAR GUIDES

NTSF120

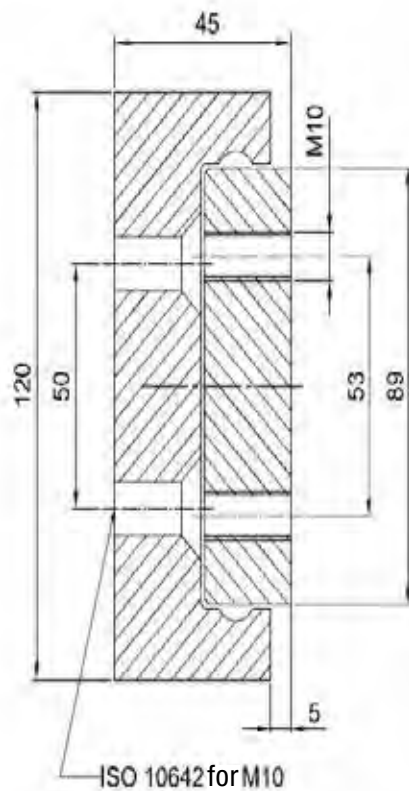

Steel thick-layer passivated

	NTSF120-160	NTSF120-200	NTSF120-300
L (mm)	160	200	300
X (mm)	80	120	220
Stroke	E-200	E-240	E-340
Load / carrier on major axis (N)	8400	9200	10300
Load / carrier on minor axis (N)	4200	4600	5150
Mounting holes slide	4 x M10	4 x M10	5 x M10
Mounting hole guide rail	ISO 10642 for M10		

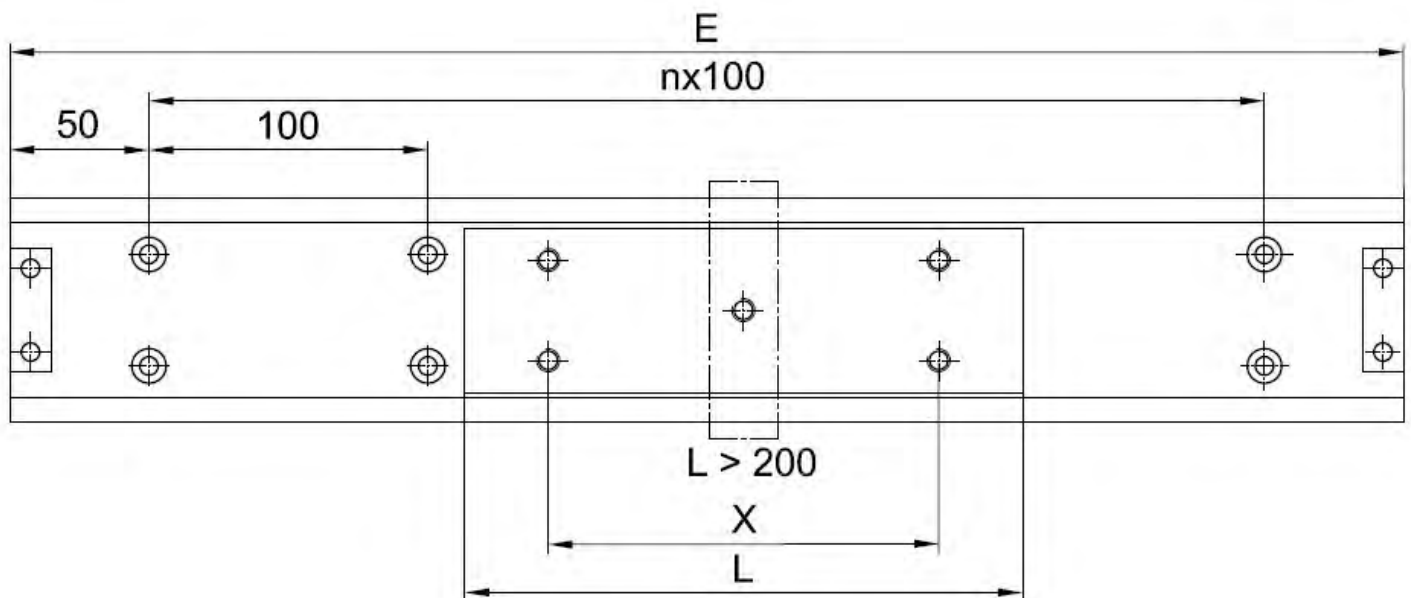

Ordercode and further options see last page. Your desired length is not listed in the table? No problem! Only the most common lengths are shown here. Please contact our application technology division.

NOTES

A large grid of graph paper for taking notes, consisting of 20 columns and 30 rows of small squares.

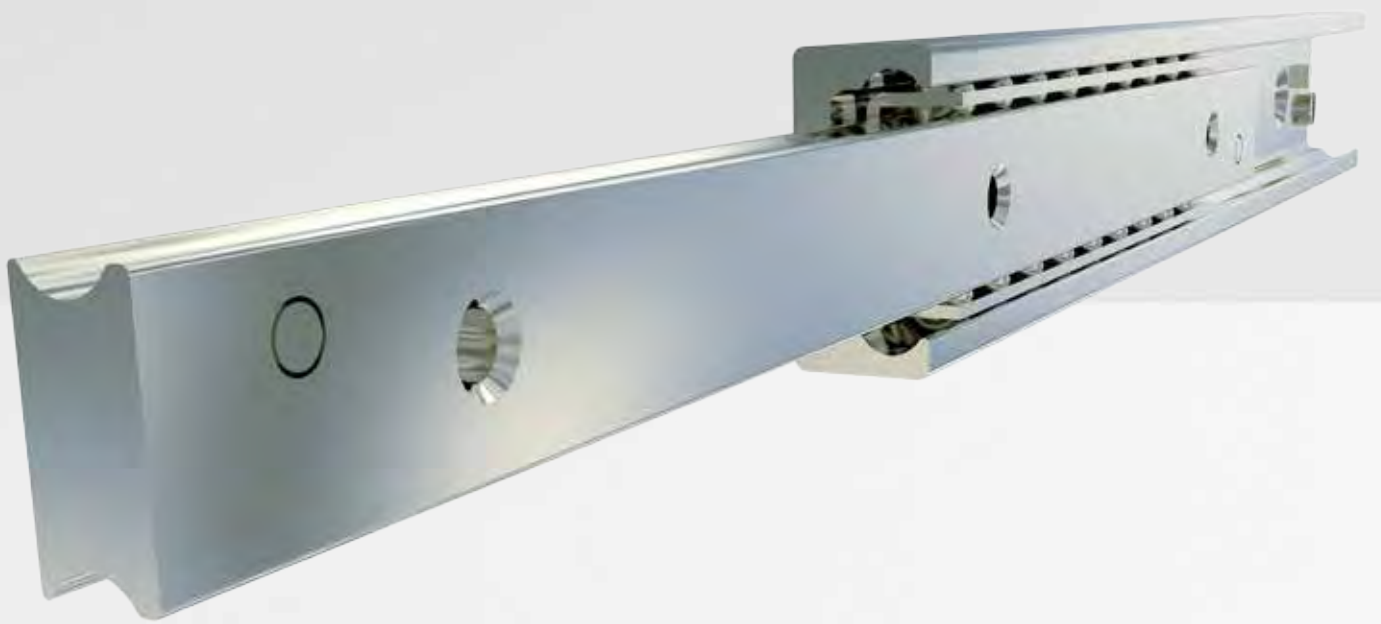

TELESCOPIC RAILS



HARDENED TELESCOPIC RAILS FOR HIGHLY DYNAMIC APPLICATIONS

PAGE 106	7.1 PRODUCT OVERVIEW
PAGE 116	7.2 PART EXTENSIONS
PAGE 120	7.3 FULL EXTENSIONS
PAGE 126	7.4 LINEAR GUIDES

PRODUCT OVERVIEW

TELESCOPIC RAILS

LST28

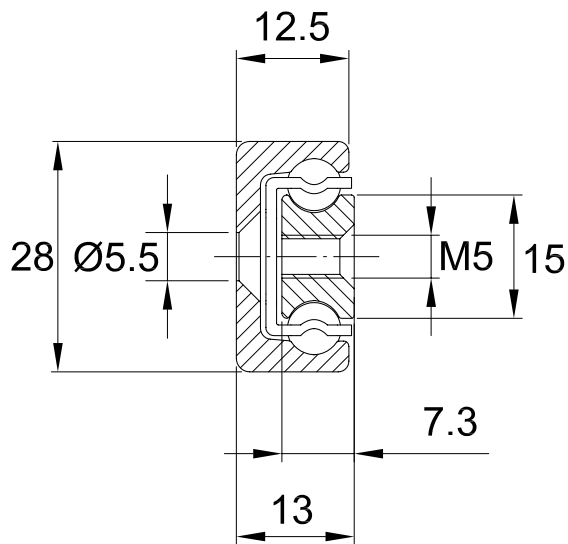

LST43

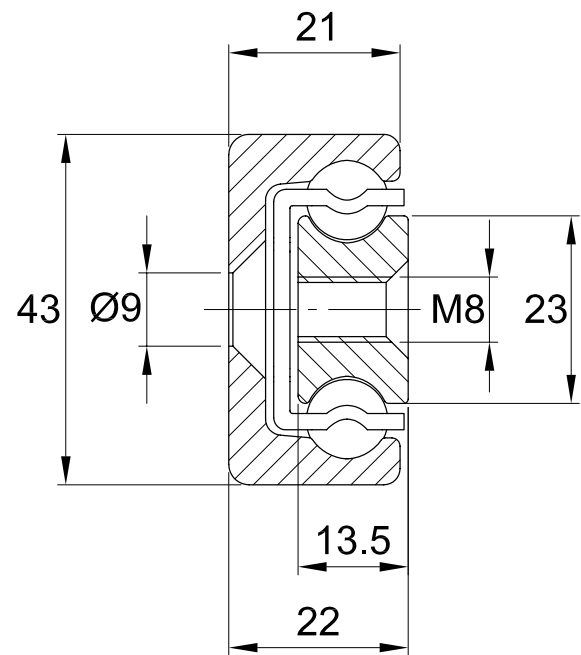

LSE28

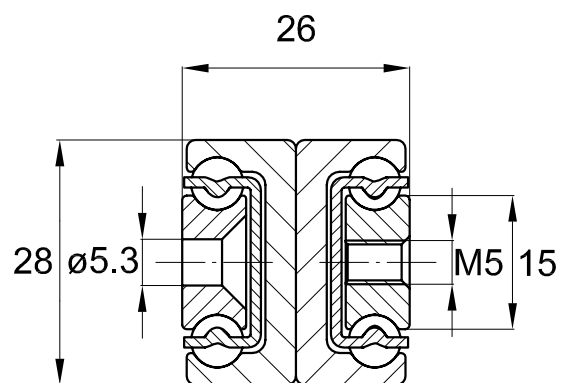

LSE43

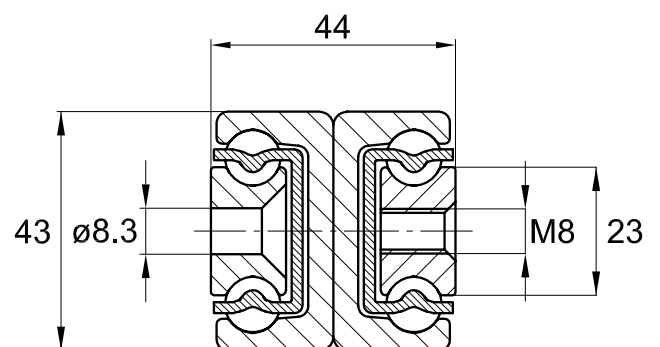

TELESCOPIC RAILS

LSS28

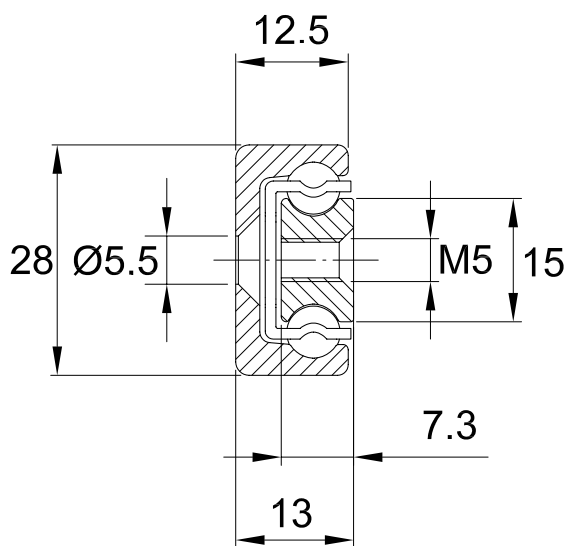

LSS43

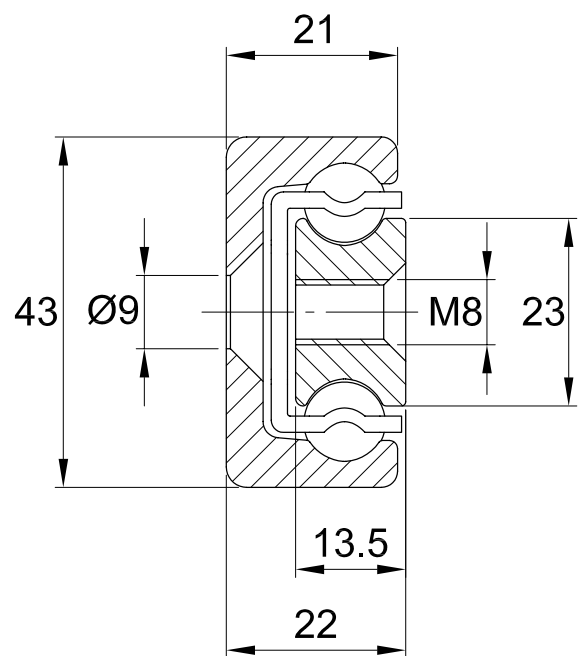

TELESCOPIC RAILS

LSS, LST AND LSE

Nadella telescopic rails are ball guided and very compact and flexible products. Made entirely of steel, with profiles cold drawn and raceways induction hardened, enables you to move heavy loads while maintaining excellent rolling features thanks to the robust ball cage interposed between the sliding elements.

The product is composed by the external drawn profile, with C shaped section, the internal slider and the ball-cage:

- Linear guide cold drawn in bearing steel with high durability; internal concave raceways with gothic arch shape, induction hardened for a high wear resistance and durability. The rails are supplied with a standard surface treatment of white zinc plating.
- Internal slider in bearing steel with high durability; internal concave raceways with gothic arch shape, induction hardened for a high wear resistance and durability. Sliders are supplied drilled with a surface treatment of electrolytic white zinc plating.
- Bent steel plate ball-cage with surface treatment of white zinc plating which holds the rolling elements consisting of steel bearing balls, which allows the reciprocal sliding of the elements; the high diameter and the narrow pitch between the balls allow a very high load capacity.

The raceways have a gothic arch shape which increases the load capacity of the system compared with the v shaped raceways.

The proposed range includes three lines:

- Semi-telescopic rails LST, where the slider can escape for more than half its length.
- Telescopic rails LSE, that allow a stroke equal to the length of the closed rail, thanks to the intermediate element that acts as a bridge between the two sliders.



- LSS rails, with one or more sliders which run inside the rail.

Our rails are available in two sizes, 28 and 43, and can be supplied in the standard version according to the present catalogue, or in several different configurations according to the requiring of the applications.

SURFACE TREATMENT

LSS and LST rails are supplied with a surface treatment of electrolytic white zinc plating on all the components (slider, rail and ball-cage). Zinc-plating treatment process is done after drilling the elements.

On request other surface treatments can be supplied (chemical nickel plating, suffix NW, phosphating).

Balls, in bearing steel, hardened, don't have any surface treatment. Upon request the rails can be equipped with balls in stainless steel.

LUBRICATION

For a proper exercise and to ensure an adequate lifetime, a film of lubricant must always be guaranteed in the contact area between the balls and the raceways of the elements (relubricate the raceways periodically according to the own specific working cycle and the environment, in order to always guarantee a layer of lubricant in the contact area between balls and raceways). The guides are provided with raceways lubricated with a bearing grease with a base of soap barium, which allows to work in a temperature range between -20°C and $+120^{\circ}\text{C}$. Please contact our technical support if you plan application with higher temperatures.

We recommend the lubrication of the raceways at least every 50 000 cycles.

For extreme working temperature, please contact our Technical service.



TELESCOPIC RAILS

LSS, LST AND LSE

LUBRICATION AND TEMPERATURE

We recommend to use the rails with lubrication on the raceways. During production the rails are equipped with a lubricant which allows to work in a range of temperatures between -20°C and $+120^{\circ}\text{C}$. Out of this range suitable mounting precautions should be evaluated: use of a lubricant for extreme temperatures, mounting with increased clearance, to remedy to the thermal expansion.

Maximum working temperature is 170°C , for higher temperature the use should happen in consideration of a reduction of the load capacity (at high temperatures the hardened raceways undergo a tempering process, reducing the surface hardness of the elements).

MAXIMUM SPEED

We suggest to work at speed not higher than 0.5 m/s in order to have a correct functioning (for rails LSE maximum speed $0,3\text{ m/s}$).

These products are suggested for applications with small inversion frequencies and accelerations (please consult the following «Suggestions for a correct mounting» paragraph).

LOAD CAPACITIES

Guide rails with ball cage have preferential load capacity with the mounting on the side (major axis).

Ideal mounting configuration is realised with two parallel guide rails, with the load to be moved uniformly distributed on the moving elements. Mounting of the guide rail to the structure and of the external load to the sliders should involve all available holes of the components.

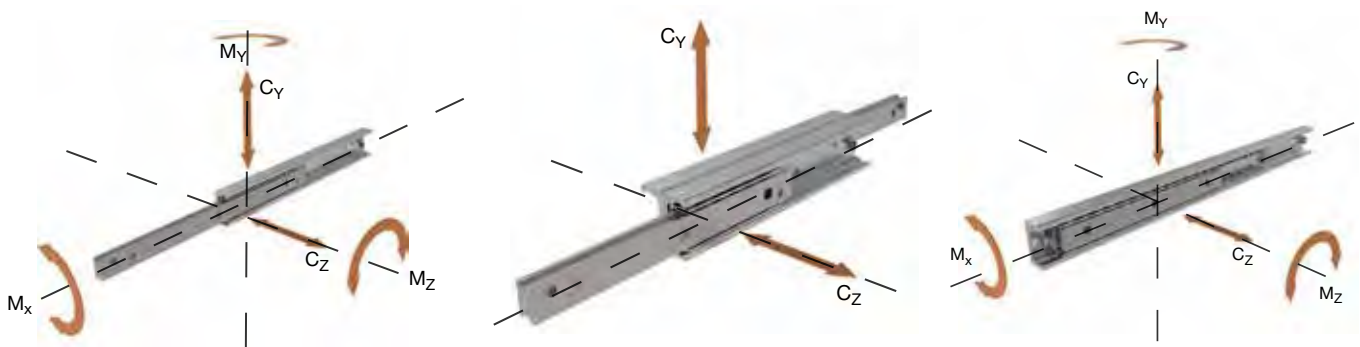

Load capacities are expressed in N (Newton), torque load capacities are expressed in Nm, refer to the Cartesian axes with origin in the centre of the slider and are valued according to standard ISO 14728-2. Tables of load capacities in the following pages refer to a single slider and are to be intended as maximum static admissible loads for a smooth operation.

In order to choose the correct guide rail we suggest to use the product with the appropriate load capacity by calculating the safety factor F_s . With more loads and torques acting simultaneously in different directions the check of the loads shouldn't be on the single component, but the contemporary action of all the components should be considered (P_{eq}).

$$F_s = \left(\frac{C_y}{P_{eq}} \right) > 1$$

$$P_{eq} = P_1 + \left(\frac{P_2}{C_z} + \frac{M_1}{M_x} + \frac{M_2}{M_y} + \frac{M_3}{M_z} \right) \times C_y$$

with:

- P_{eq}** equivalent load in Y direction resulting from the combination of all the loads and torques acting contemporary on the slider
- P₁** load applied in the middle of the slider in Y direction
- P₂** load applied in the middle of the slider in Z direction
- M₁** torque applied in the middle of the slider around X axis
- M₂** torque applied in the middle of the slider around Y axis
- M₃** torque applied in the middle of the slider around Z axis
- C_y** maximum admissible static load capacity in Y direction
- C_z** maximum admissible static load capacity in Z direction
- M_x** maximum admissible static torque load capacity around X axis
- M_y** maximum admissible static torque load capacity around Y axis
- M_z** maximum admissible static torque load capacity around Z axis

TELESCOPIC RAILS

LSS, LST AND LSE

LIFETIME

Lifetime of the guide rail is the maximum stroke (in km for rails LSS) or maximum number of cycles (for rails LST and LSE), that the guide rail will be able to reach before the appearances of plastic deformation on the raceways.

For rails LSS

$$L_{\text{km}} = 100 \times \left(\frac{C_{100}}{P_{\text{eq}}} \times \frac{1}{f} \right)^3$$

For rails LST and LSE

$$L_{\text{cycles}} = 100000 \times \left(\frac{C_{\text{dyn}}}{P_{\text{eq}}} \times \frac{1}{f} \right)^3$$

with:

C₁₀₀ dynamic load in Y direction [N], valued according to standard ISO 14728-1 for the calculation of the lifetime in km (rails LSS)

C_{dyn} dynamic load in Y direction [N], valued according to standard ISO 14728-1 for calculation of the lifetime in cycles (rails LST and LSE)

P_{eq} equivalent load in Y direction resulting from the combination of all the loads and torques acting contemporary on the slider (see formula above)

f application coefficient

Smooth operation at low speed at constant load without shocks

..... **f = 1 - 1.2**

Smooth operation with load variation

..... **f = 1.2 - 1.5**

Operation with small shocks and vibrations

..... **f = 1.5 - 2**

High accelerations, shocks and vibrations

..... **f = 2 - 4**

DEFLECTION

The deflection is the elastic deformation you can register at the edge of the opened rail when a load is applied.

With semi-telescopic rails LST, that can partially exit from the rail, the deflection will depend almost exclusively on the rigidity of the structures connected to the guide elements.

For telescopic rails LSE, please refer to the values of deflection written in the tables of the load capacities and which refer to the maximum load (Cy) applied in the middle of the opened slider. For applied loads inferior to the maximum load capacity, please reduce the deflection proportionally.



SUGGESTIONS FOR A CORRECT MOUNTING

In guide systems based on ball-cage, the sliding occurs thanks to the simultaneous movement of the slider and of the ball-cage: the slider, moved by a drive system or manually, sets in motion the ball-cage, which will cover half of the stroke done by the slider, until reaching the end-stop.

During operation, with the succession of working cycles and consequent motion reversals, imperceptible displacements of the ball-cage, in relation to the position of the slider, occur, due to the inertia to the movement of the ball-cage that doesn't engage immediately when the slider starts its race.

This process, that is defined displacement and leads to a gradual reduction of the stroke and consequent dragging of the ball-cage on the raceways, can be slowed down by a correct use, with races constantly up to the end stops and low speed and acceleration. The restoration of the proper functioning must be done by setting a forced cycle up to the end stop: when the movement of the slider is commanded by a drive system, we recommend to provide a peak motor torque 10 times higher (friction coefficient in normal condition is 0,01).

Guide systems based on ball-cages are recommended for movement on the horizontal plane. Movement in the vertical direction is not recommended because the ball-cage tends to fall by gravity, accelerating the process of displacement.

Providing an external end stop is highly recommended in order not to discharge on the screw of the internal stop the arrest of the machine.

TELESCOPIC RAILS

LSS, LST AND LSE

During the mounting of LSS and LST rails we suggest to work the holes in the support in order to avoid any interference between the screws and the sliders (see table below).

Size	Chamfer
LSS28, LST28	1 x 45°
LSS43, LST43	1.5 x 45°

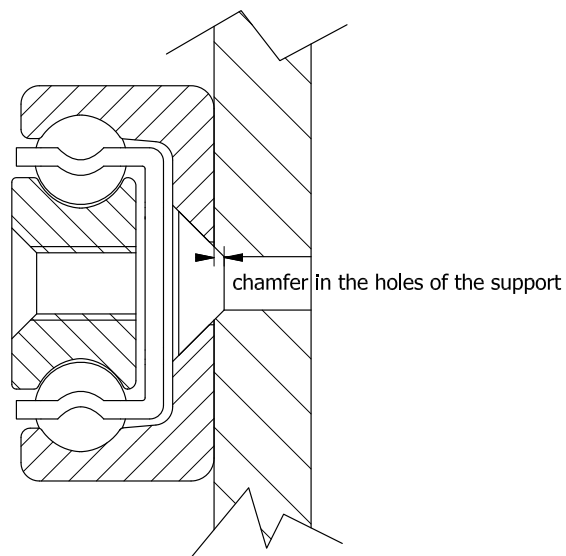

EXTERNAL END STOPS

Provide external end stop in order not to discharge on the screws of the internal stop the arrest of the machine.

Mounting screws of resistance class 10.9 are recommended for mounting.

FRICTION COEFFICIENT

The friction coefficient in normal condition is equal to 0,01.

When the movement of the slider is commanded by a drive system, we recommend to provide a peak motor torque 10 times higher than the standard required due to the process of displacement (see the "Suggestion for a correct mounting" paragraph).

For telescopic rails LSE the force necessary for closing the rails and let the slider go back in central position is increased from the deflection due to the extraction of the moving elements.

NOTES

A large grid of graph paper for taking notes, consisting of 20 columns and 30 rows of small squares.

PART EXTENSIONS

LST

LST 28



LST 43



Part extensions LST of Nadella allow the partial extraction of the slider which escapes for more than half its length from the edge of the rail, while maintaining a smooth and regular movement through the interposition of a robust metal ball-cage. The perfect solution for all applications requiring a protruding extraction.

LST guide rail is available in two sizes, LST28 and LST43, and several standard lengths (on request different rail lengths can be provided that will be managed as special items).

LOAD CAPACITIES

Part extensions with ball cage have preferential load capacity with the mounting on the side (major axis).

Ideal mounting configuration is realised with two parallel guide rails, with the load to be moved uniformly distributed on the moving elements. Mounting of the guide rail to the structure and of the external load to the sliders should involve all available holes of the components.

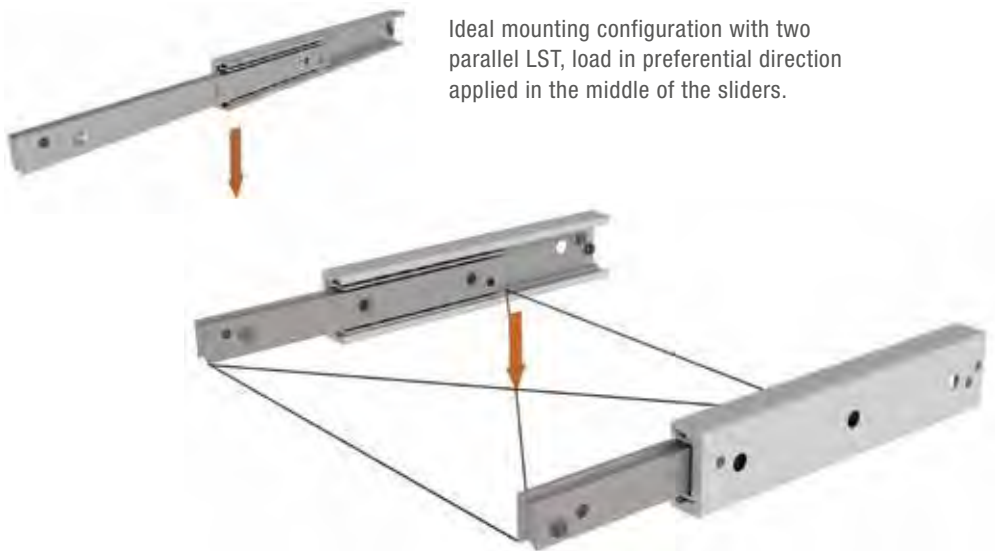

Ideal mounting configuration with two parallel LST, load in preferential direction applied in the middle of the sliders.

DOUBLE STROKE

In order to obtain the double stroke and allow the slider to escape in both directions, please remove the screw at the edge of the rail.



Remove the screw at the edge of the rail for double stroke.

PART EXTENSIONS

LST 28

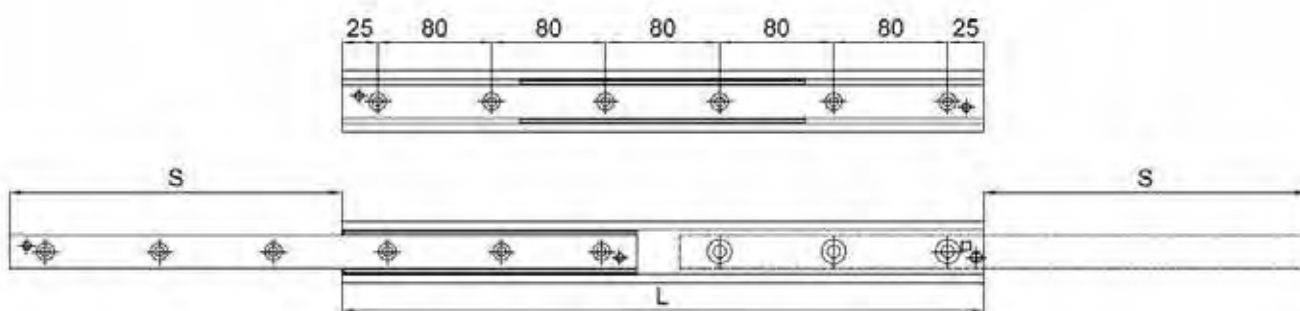
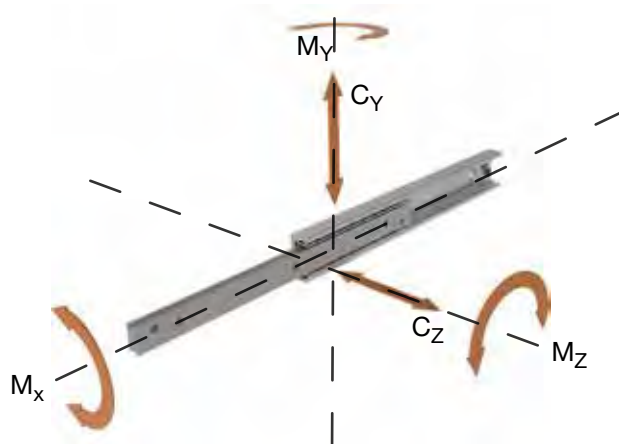
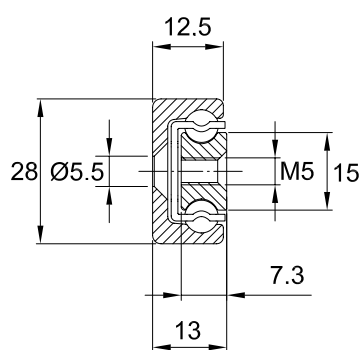

Order Number	L	S	Cy	Cz	Mx	My	Mz	Cdyn ⁽¹⁾	Mass
	[mm]	[mm]	[N]	[N]	[Nm]	[Nm]	[Nm]	[N]	[kg]
LST28-130	130	73	943	660	30	30	43	3451	0.28
LST28-210	210	113	1731	1212	54	86	123	4606	0.45
LST28-290	290	153	2526	1769	78	170	243	5449	0.62
LST28-370	370	193	3320	2325	102	282	403	6119	0.80
LST28-450	450	233	4111	2878	126	422	603	6681	0.97
LST28-530	530	273	4899	3430	150	590	842	7170	1.14
LST28-610	610	323	5215	3651	168	733	1047	6976	1.31
LST28-690	690	363	5994	4197	192	948	1355	7410	1.49
LST28-770	770	398	6771	4741	216	1191	1701	7805	1.66
LST28-850	850	433	8025	5619	246	1532	2188	8687	1.84
LST28-930	930	473	8802	6163	270	1835	2621	8997	2.01
LST28-1010	1010	523	9096	6369	288	2080	2970	8819	2.18
LST28-1090	1090	563	9868	6910	312	2430	3470	9115	2.36
LST28-1170	1170	603	10639	7449	336	2806	4008	9394	2.53

Load capacity for single rail

⁽¹⁾ Cdyn is used for lifetime calculation

DOUBLE STROKE

In order to obtain the double stroke and allow the slider to escape in both directions, please remove the screw at the edge of the rail.

LST43

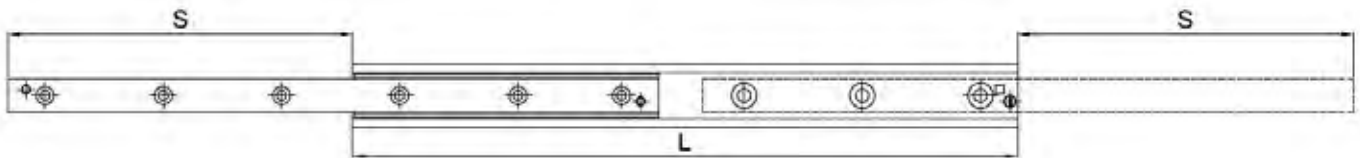
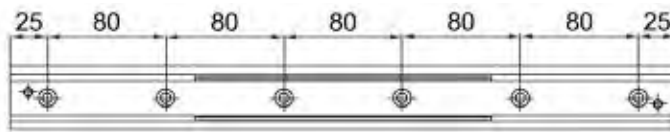
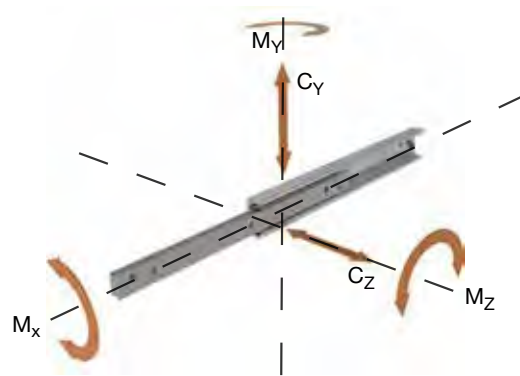
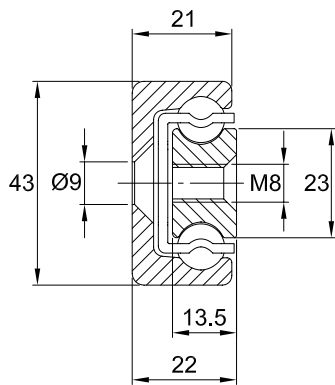

Order Number	L	S	Cy	Cz	Mx	My	Mz	Cdyn ⁽¹⁾	Mass
	[mm]		[N]		[Nm]			[N]	[kg]
LST43-210	210	123	2223	1556	115	117	166	7268	1.10
LST43-290	290	158	3945	2762	185	272	389	10337	1.53
LST43-370	370	208	4610	3228	231	412	589	10319	1.95
LST43-450	450	243	6376	4465	300	676	965	12534	2.39
LST43-530	530	278	8187	5733	369	1003	1433	14466	2.82
LST43-610	610	313	10025	7020	439	1394	1991	16178	3.26
LST43-690	690	363	10601	7423	485	1690	2414	15804	3.67
LST43-770	770	398	12428	8702	554	2187	3123	17266	4.11
LST43-850	850	433	14270	9992	623	2746	3922	18609	4.54
LST43-930	930	483	14823	10379	670	3155	4505	18246	4.96
LST43-1010	1010	518	16654	11662	739	3819	5454	19446	5.40
LST43-1090	1090	568	17212	12052	785	4297	6136	19139	5.82
LST43-1170	1170	603	19035	13328	854	5066	7234	20230	6.25
LST43-1250	1250	638	20866	14611	924	5897	8422	21262	6.68
LST43-1330	1330	688	21410	14992	970	6486	9263	20967	7.10
LST43-1410	1410	723	23234	16269	1039	7421	10598	21922	7.54
LST43-1490	1490	758	25065	17551	1108	8418	12022	22835	7.97
LST43-1570	1570	793	26901	18836	1178	9478	13535	23707	8.41
LST43-1650	1650	843	27423	19202	1224	10218	14593	23409	8.82
LST43-1730	1730	878	29253	20483	1293	11381	16254	24231	9.26
LST43-1810	1810	928	29780	20852	1339	12190	17410	23964	9.68
LST43-1890	1890	963	31603	22129	1408	13456	19218	24742	10.11
LST43-1970	1970	1013	32134	22500	1455	14334	20472	24499	10.53

Load capacity for single rail

⁽¹⁾ Cdyn is used for lifetime calculation

DOUBLE STROKE

In order to obtain the double stroke and allow the slider to escape in both directions, please remove the screw at the edge of the rail.

FULL EXTENSIONS

LSE

LSE 28



LSE 43



Full extensions LSE allow a stroke equal to the length of the closed rail, thanks to the intermediate element that acts as a bridge between the two sliders.

LSE guides allow a smooth and regular movement and are the perfect solution for all the applications requiring a total telescopic extraction.

LSE guide rail is available in two sizes, LSE28 and LSE43, and several standard lengths (on request different rail lengths can be provided that will be managed as special items).

LOAD CAPACITIES

Full extensions with ball cage have preferential load capacity with the mounting on the side (major axis). Ideal mounting configuration is realised with two parallel guide rails, with the load to be moved uniformly distributed on the moving elements. Mounting of the guide rail to the structure and of the external load to the sliders should involve all available holes of the components.

AVAILABLE HOLE CONFIGURATIONS

LSE full extensions are available with countersunk holes (suffix V) and threaded holes (suffix F), or in the mixed version (suffix M), with one slider with countersunk holes and one slider with threaded holes.

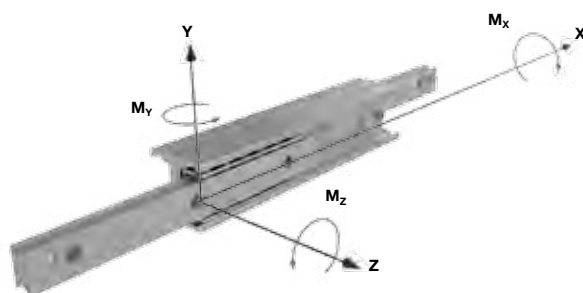

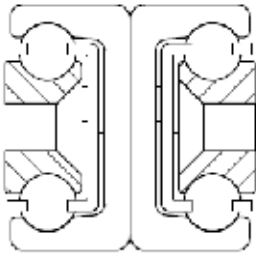

LSE28-...V
LSE43-...V

Code example: LSE28-450 V, full extension LSE size 28, closed length 450 mm, countersunk holes in both sliders

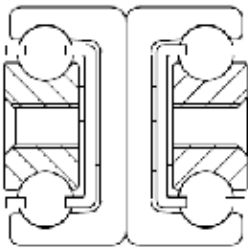

LSE28-...F
LSE43-...F

Code example: LSE43-770 F, full extension LSE size 43, closed length 770 mm, threaded holes in both sliders.

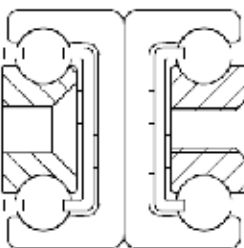

LSE28-...M
LSE43-...M

Code example: LSE43-1170 M, full extension LSE size 43, closed length 1170 mm, threaded holes on one slider and countersunk holes in the opposite one.

DOUBLE STROKE

In order to obtain the double stroke and allow the slider to escape in both directions, please remove the screw at the edge of the intermediate element.



Remove the screw at the edge of the rail for double stroke.



Ideal mounting configuration with two parallel LSE, load in preferential direction applied in the middle of the sliders.

FULL EXTENSIONS

LSE 28

LSE 28-..M

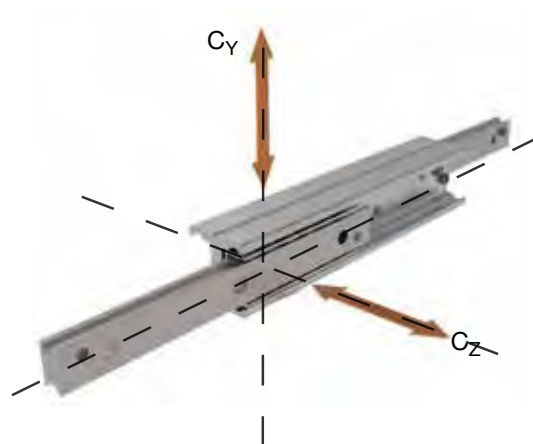
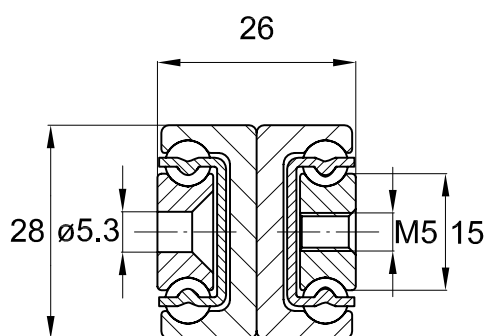

LSE 28-..F

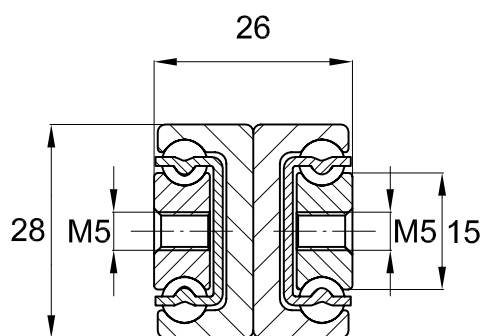

LSE 28-..V

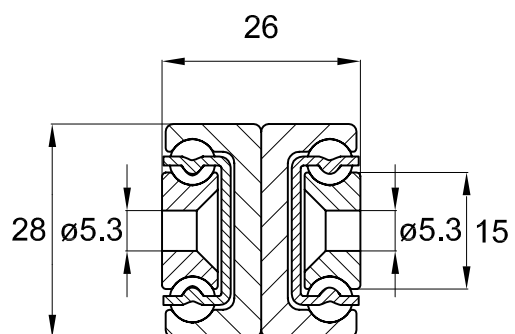

LSE 28

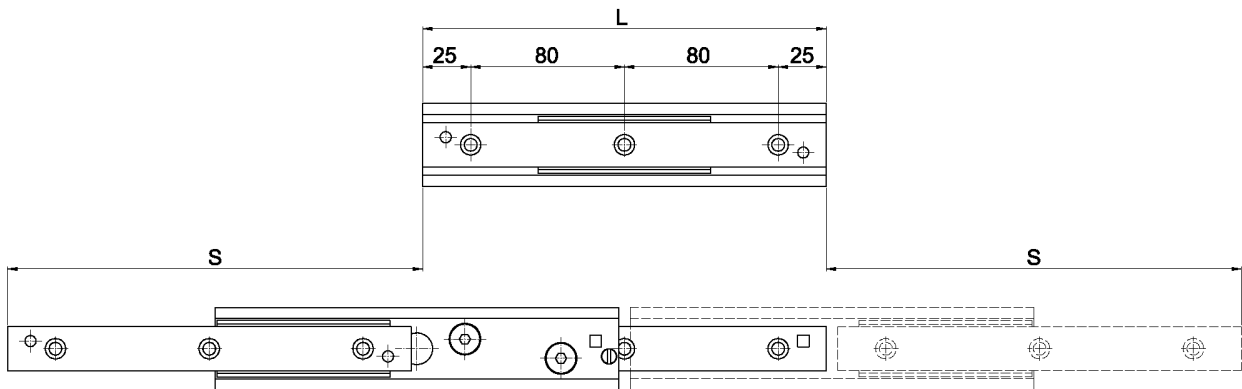

Order Number	L	S	Cy	Cz	Cdyn ⁽¹⁾	Deflection	Mass
	[mm]		[N]			[mm]	[kg]
LSE28-130	130	146	548	487	1006	1	0.55
LSE28-210	210	226	998	617	2115	3	0.90
LSE28-290	290	306	1125	464	2643	4	1.25
LSE28-370	370	386	1108	372	2824	6	1.60
LSE28-450	450	466	1042	310	2817	7	1.94
LSE28-530	530	546	952	266	2714	9	2.29
LSE28-610	610	646	843	219	2536	11	2.63
LSE28-690	690	726	772	196	2420	12	2.98
LSE28-770	770	806	710	177	2305	14	3.32
LSE28-850	850	866	669	169	2225	14	3.68
LSE28-930	930	946	620	155	2126	15	4.02
LSE28-1010	1010	1046	572	138	2025	18	4.36
LSE28-1090	1090	1126	537	129	1951	19	4.71
LSE28-1170	1170	1206	503	120	1895	21	5.06

Load capacity for single rail

⁽¹⁾ Cdyn is used for lifetime calculation

DOUBLE STROKE

In order to obtain the double stroke and allow the slider to escape in both directions, please remove the screw at the edge of the intermediate element.

FULL EXTENSIONS

LSE 43

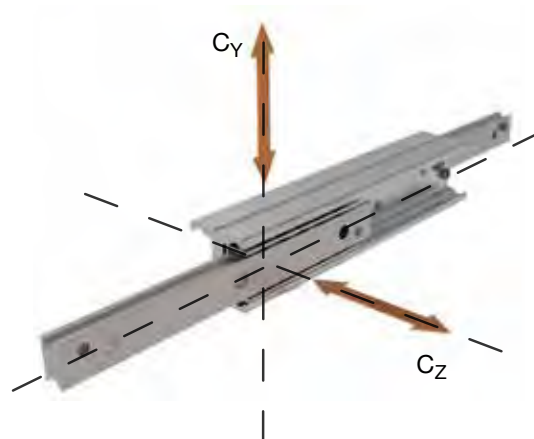

LSE 43-..M

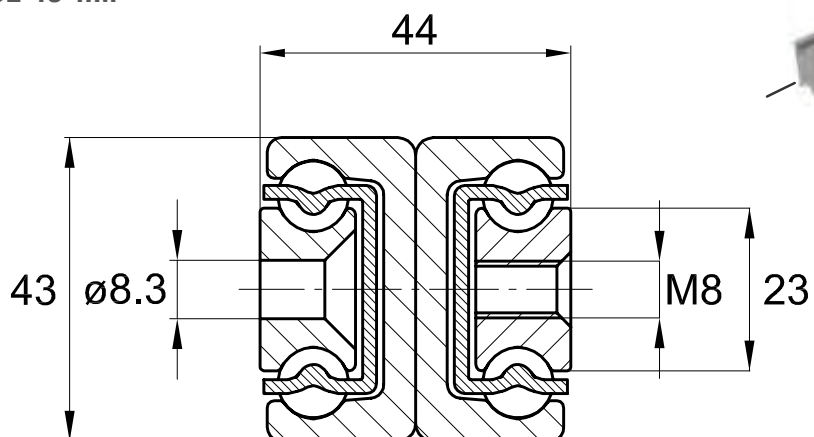

LSE 43-..F

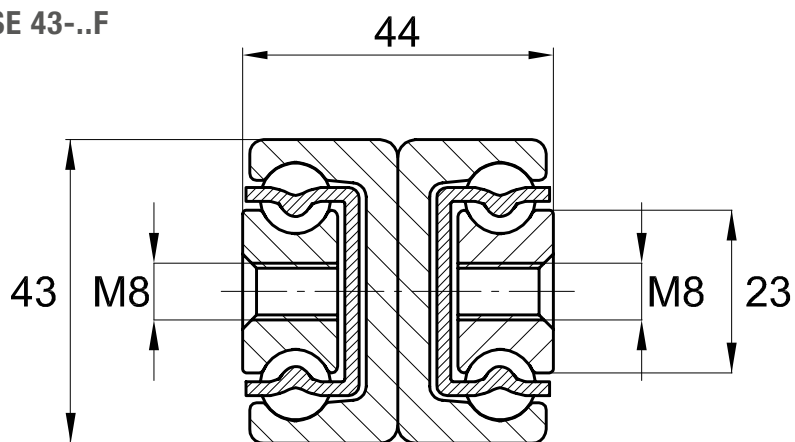

LSE 43-..V

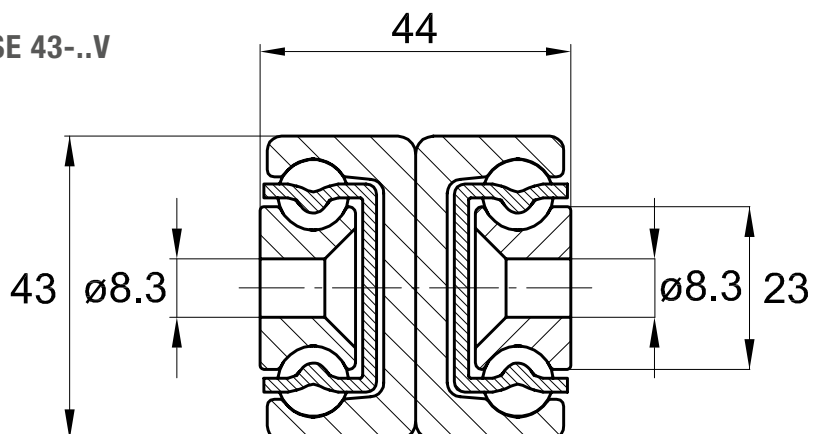

LSE 43

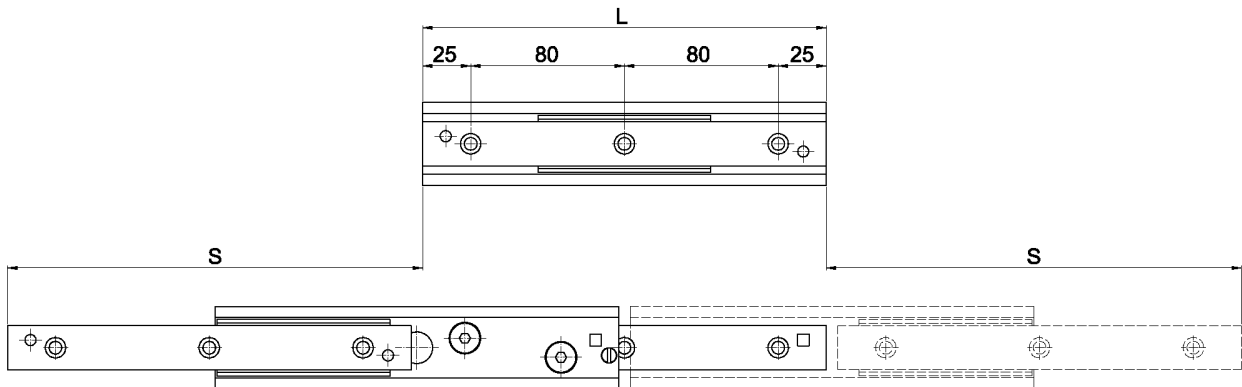

Order Number	L	S	Cy	Cz	Cdyn ⁽¹⁾	Deflection	Mass
	[mm]	[mm]	[N]	[N]	[N]	[mm]	[kg]
LSE43-210	210	246	1209	880	2454	3	2.20
LSE43-290	290	316	1982	1549	4480	5	3.07
LSE43-370	370	416	1987	1466	4806	6	3.90
LSE43-450	450	486	2209	1496	5625	7	4.77
LSE43-530	530	556	2326	1392	6195	9	5.64
LSE43-610	610	626	2562	1262	6619	11	6.51
LSE43-690	690	726	2239	1063	6519	12	7.35
LSE43-770	770	796	2237	986	6716	14	8.22
LSE43-850	850	866	2214	918	6834	16	9.10
LSE43-930	930	966	2096	808	6710	18	9.92
LSE43-1010	1010	1036	2056	763	6738	20	10.80
LSE43-1090	1090	1136	1834	685	6511	21	11.63
LSE43-1170	1170	1206	1895	652	6533	24	12.50
LSE43-1250	1250	1276	1850	622	6500	25	13.37
LSE43-1330	1330	1376	1694	570	6364	28	14.20
LSE43-1410	1410	1446	1626	547	6304	29	15.07
LSE43-1490	1490	1516	1562	525	6187	29	15.90
LSE43-1570	1570	1586	1504	506	6143	30	16.81
LSE43-1650	1650	1686	1399	470	5965	33	17.65
LSE43-1730	1730	1756	1352	455	5852	33	18.52
LSE43-1810	1810	1856	1267	426	5690	36	19.36
LSE43-1890	1890	1926	1228	413	5593	37	20.22
LSE43-1970	1970	2026	1157	389	5445	40	21.06

Load capacity for single rail

⁽¹⁾ Cdyn is used for lifetime calculation

DOUBLE STROKE

In order to obtain the double stroke and allow the slider to escape in both directions, please remove the screw at the edge of the intermediate element.

LINEAR GUIDES

LSS

LSS 28



LSS 43



With LSS linear guides the movement is achieved through one or more sliders which run inside the guide rail. Several different combinations are possible and the final product can be configured out according to the application requests.

LSS WITH SINGLE SLIDER

In the standard configuration the final product is composed by the guide rail inside which run a single ball-cage and a single slider.

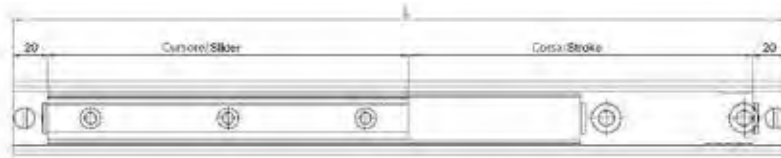

LSS28-total length L-stroke

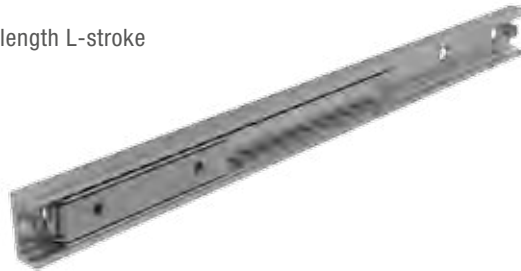

LSS WITH TWO INDEPENDENT SLIDERS

This configuration allows the movement, inside the guide rail, of two ball-cages, inside each ball-cage one or more sliders. The two ball-cages can run in opposing directions.

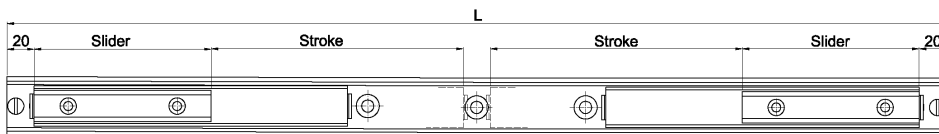

LSS43-total length L-2xstroke



LSS WITH TWO SYNCHRONISED SLIDERS

This configuration allows the movement inside the ball-cage of two synchronized sliders.

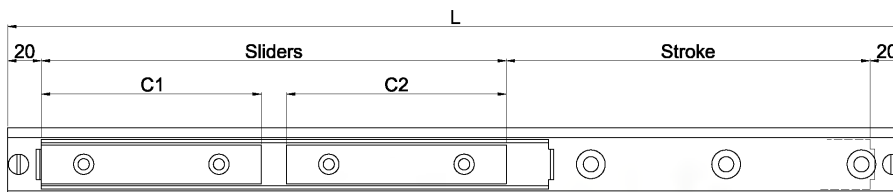

LSS43-total length L-stroke-2xlength of the slider

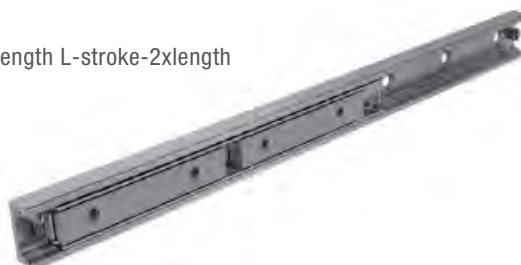

LINEAR GUIDES

LSS28

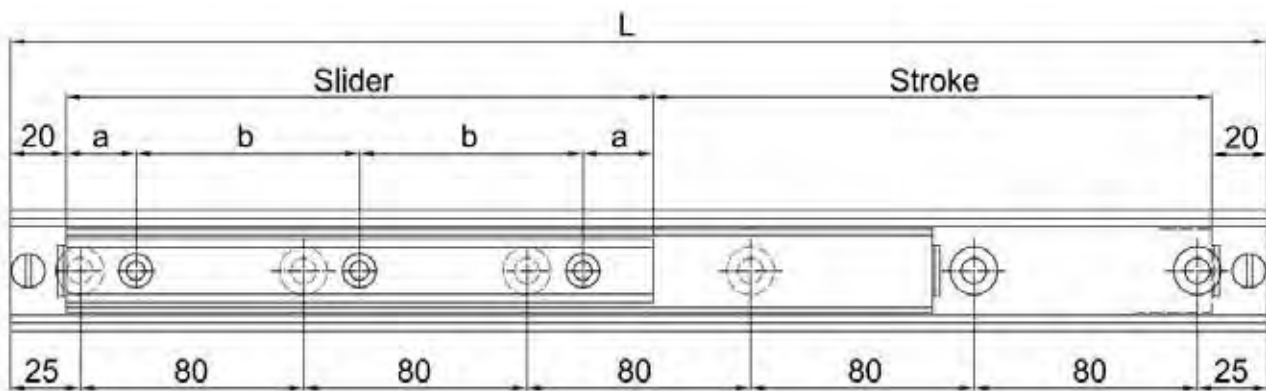
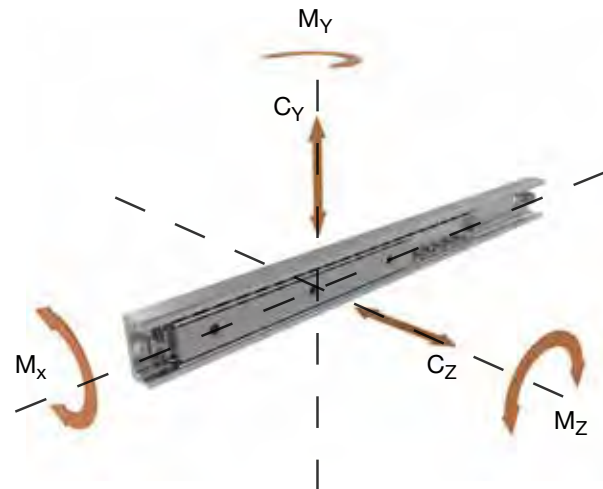
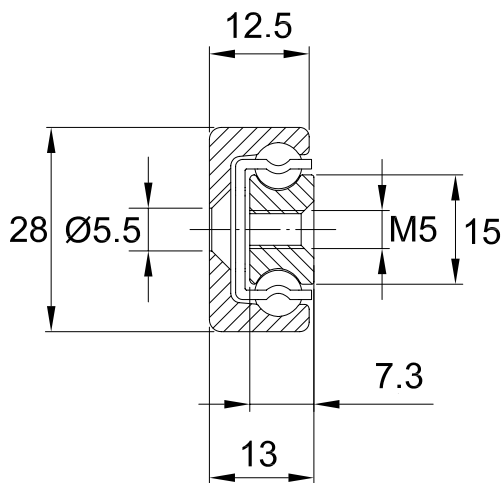

Slider	a	b	Cy	Cz	Mx	My	Mz	C ₁₀₀ ⁽¹⁾
	[mm]		[N]			[Nm]		[N]
60	10	20	4756	3330	30	30	43	9165
80	10	60	6659	4663	42	55	78	11626
130	25	80	11415	7993	72	145	207	16992
210	25	80	19025	13322	120	387	552	24326
290	25	80	26635	18650	168	730	1043	30801
370	25	80	34245	23979	216	1187	1695	36736
450	25	80	41856	29308	264	1763	2518	42283

⁽¹⁾ C₁₀₀ is used for lifetime calculation

L = AVAILABLE LENGTHS [MM]:

130, 210, 290, 370, 450, 530, 610, 690, 770, 850, 930, 1010, 1170, 1330, 1490, 1650

Other lengths are available on request up to a maximum length of 2000 mm

Code example: **LSS28 690 360**

Rail LSS28, length 690 mm, stroke 360 mm (slider length = 290 mm = 690 – 360 mm – stop length 2x20)

LINEAR GUIDES

LSS43

7.4

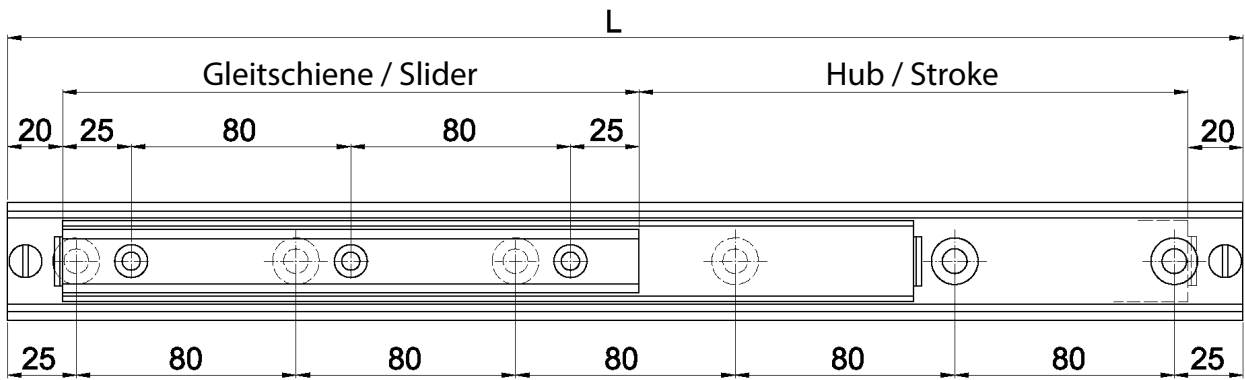
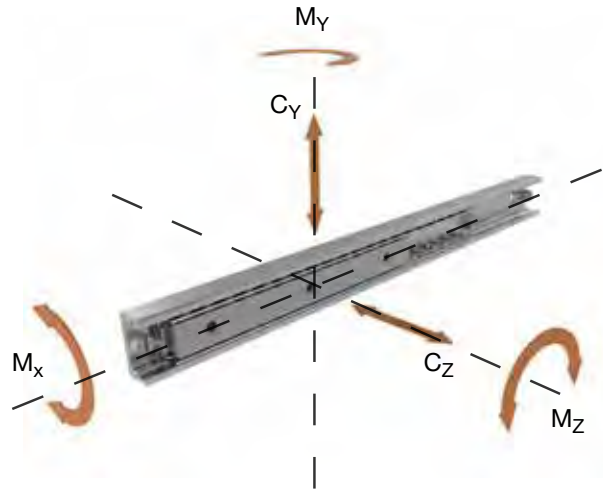
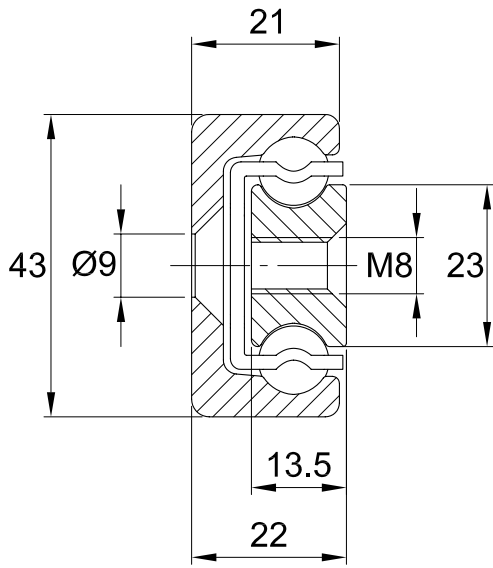

Slider [mm]	Cy [N]	Cz [N]	Mx [Nm]	My [Nm]	Mz [Nm]	C ₁₀₀ ⁽¹⁾ [N]
130	19909	13940	185	276	394	35532
210	32352	22653	300	682	974	50002
290	47283	33108	439	1394	1993	65273
370	59726	41821	554	2195	3135	76899
450	72169	50533	670	3155	4505	87813
530	87100	60988	808	4543	6489	100188
610	99543	69701	924	5909	8441	110018

⁽¹⁾ C₁₀₀ is used for lifetime calculation

L = AVAILABLE LENGTHS [MM]:

290, 370, 450, 530, 610, 690, 770, 850, 930, 1010, 1170, 1330, 1490, 1650, 1810, 1970

Other lengths are available on request up to a maximum length of 2000 mm

Code example: **LSS43 690 520**

Rail LSS43, length 690 mm, stroke 520 mm (slider length = 130 mm = 690 – 520 mm – stop length 2x20)

GUIDE RAILS LSS

STANDARD CONFIGURATIONS

Order Number	Guide length	Stroke	Slider length	Mass
	[mm]			[kg]
LSS28-130-30	130	30	60	0,23
LSS28-210-90	210	90	80	0,36
LSS28-210-110	210	110	60	0,34
LSS28-290-120	290	120	130	0,53
LSS28-290-170	290	170	80	0,48
LSS28-290-190	290	190	60	0,46
LSS28-370-200	370	200	130	0,64
LSS28-370-250	370	250	80	0,59
LSS28-370-270	370	270	60	0,57
LSS28-450-200	450	200	210	0,83
LSS28-450-280	450	280	130	0,75
LSS28-450-330	450	330	80	0,70
LSS28-450-350	450	350	60	0,68
LSS28-530-280	530	280	210	0,94
LSS28-530-360	530	360	130	0,86
LSS28-530-410	530	410	80	0,81
LSS28-610-280	610	280	290	1,13
LSS28-610-360	610	360	210	1,05
LSS28-610-440	610	440	130	0,98
LSS28-610-490	610	490	80	0,92
LSS28-690-360	690	360	290	1,25
LSS28-690-440	690	440	210	1,17
LSS28-690-520	690	520	130	1,09
LSS28-770-360	770	360	370	1,44
LSS28-770-440	770	440	290	1,36
LSS28-770-520	770	520	210	1,28
LSS28-770-600	770	600	130	1,19
LSS28-850-440	850	440	370	1,55
LSS28-850-520	850	520	290	1,47
LSS28-850-600	850	600	210	1,39
LSS28-850-680	850	680	130	1,31
LSS28-930-440	930	440	450	1,74
LSS28-930-520	930	520	370	1,66
LSS28-930-600	930	600	290	1,58
LSS28-930-680	930	680	210	1,50
LSS28-930-760	930	760	130	1,42
LSS28-1010-520	1010	520	450	1,85
LSS28-1010-600	1010	600	370	1,77
LSS28-1010-680	1010	680	290	1,69
LSS28-1010-760	1010	760	210	1,61
LSS28-1010-840	1010	840	130	1,54
LSS28-1170-680	1170	680	450	2,08
LSS28-1170-760	1170	760	370	1,99
LSS28-1170-840	1170	840	290	1,92
LSS28-1170-920	1170	920	210	1,83
LSS28-1330-840	1330	840	450	2,30
LSS28-1330-920	1330	920	370	2,22
LSS28-1330-1000	1330	1000	290	2,14
LSS28-1330-1080	1330	1080	210	2,06
LSS28-1490-1000	1490	1000	450	2,52
LSS28-1490-1080	1490	1080	370	2,44
LSS28-1490-1160	1490	1160	290	2,37
LSS28-1650-1160	1650	1160	450	2,75

Order Number	Guide length	Stroke	Slider length	Mass
	[mm]			[kg]
LSS43-290-120	290	120	130	1,27
LSS43-370-200	370	200	130	1,54
LSS43-450-200	450	200	210	2,00
LSS43-450-280	450	280	130	1,79
LSS43-530-280	530	280	130	2,27
LSS43-530-360	530	360	130	2,06
LSS43-610-280	610	280	290	2,74
LSS43-610-360	610	360	210	2,52
LSS43-610-440	610	440	130	2,33
LSS43-690-360	690	360	290	3,01
LSS43-690-440	690	440	210	2,79
LSS43-690-520	690	520	130	2,58
LSS43-770-360	770	360	370	3,47
LSS43-770-440	770	440	290	3,26
LSS43-770-520	770	520	210	3,06
LSS43-770-600	770	600	130	2,85
LSS43-850-440	850	440	370	3,74
LSS43-850-520	850	520	290	3,53
LSS43-850-600	850	600	210	3,31
LSS43-850-680	850	680	130	3,12
LSS43-930-440	930	440	450	4,21
LSS43-930-520	930	520	370	3,99
LSS43-930-600	930	600	290	3,80
LSS43-930-680	930	680	210	3,58
LSS43-930-760	930	760	130	3,37
LSS43-1010-520	1010	520	450	4,48
LSS43-1010-600	1010	600	370	4,27
LSS43-1010-680	1010	680	290	4,05
LSS43-1010-760	1010	760	210	3,85
LSS43-1010-840	1010	840	130	3,64
LSS43-1170-600	1170	600	530	5,21
LSS43-1170-680	1170	680	450	5,00
LSS43-1170-760	1170	760	370	4,79
LSS43-1170-840	1170	840	290	4,59
LSS43-1170-920	1170	920	210	4,38
LSS43-1330-680	1330	680	610	5,95
LSS43-1330-760	1330	760	530	5,74
LSS43-1330-840	1330	840	450	5,52
LSS43-1330-920	1330	920	370	5,32
LSS43-1330-1000	1330	1000	290	5,11
LSS43-1330-1080	1330	1080	210	4,90
LSS43-1490-840	1490	840	610	6,47
LSS43-1490-920	1490	920	530	6,26
LSS43-1490-1000	1490	1000	450	6,06
LSS43-1490-1080	1490	1080	370	5,85
LSS43-1490-1160	1490	1160	290	5,63
LSS43-1490-1240	1490	1240	210	5,43
LSS43-1650-1000	1650	1000	610	6,99
LSS43-1650-1080	1650	1080	530	6,80
LSS43-1650-1160	1650	1160	450	6,58
LSS43-1650-1240	1650	1240	370	6,37
LSS43-1650-1320	1650	1320	290	6,17
LSS43-1650-1400	1650	1400	210	5,96
LSS43-1810-1160	1810	1160	610	7,53
LSS43-1810-1240	1810	1240	530	7,32
LSS43-1810-1320	1810	1320	450	7,10
LSS43-1810-1400	1810	1400	370	6,91
LSS43-1810-1480	1810	1480	290	6,69
LSS43-1970-1320	1970	1320	610	8,05
LSS43-1970-1400	1970	1400	530	7,84

NOTES

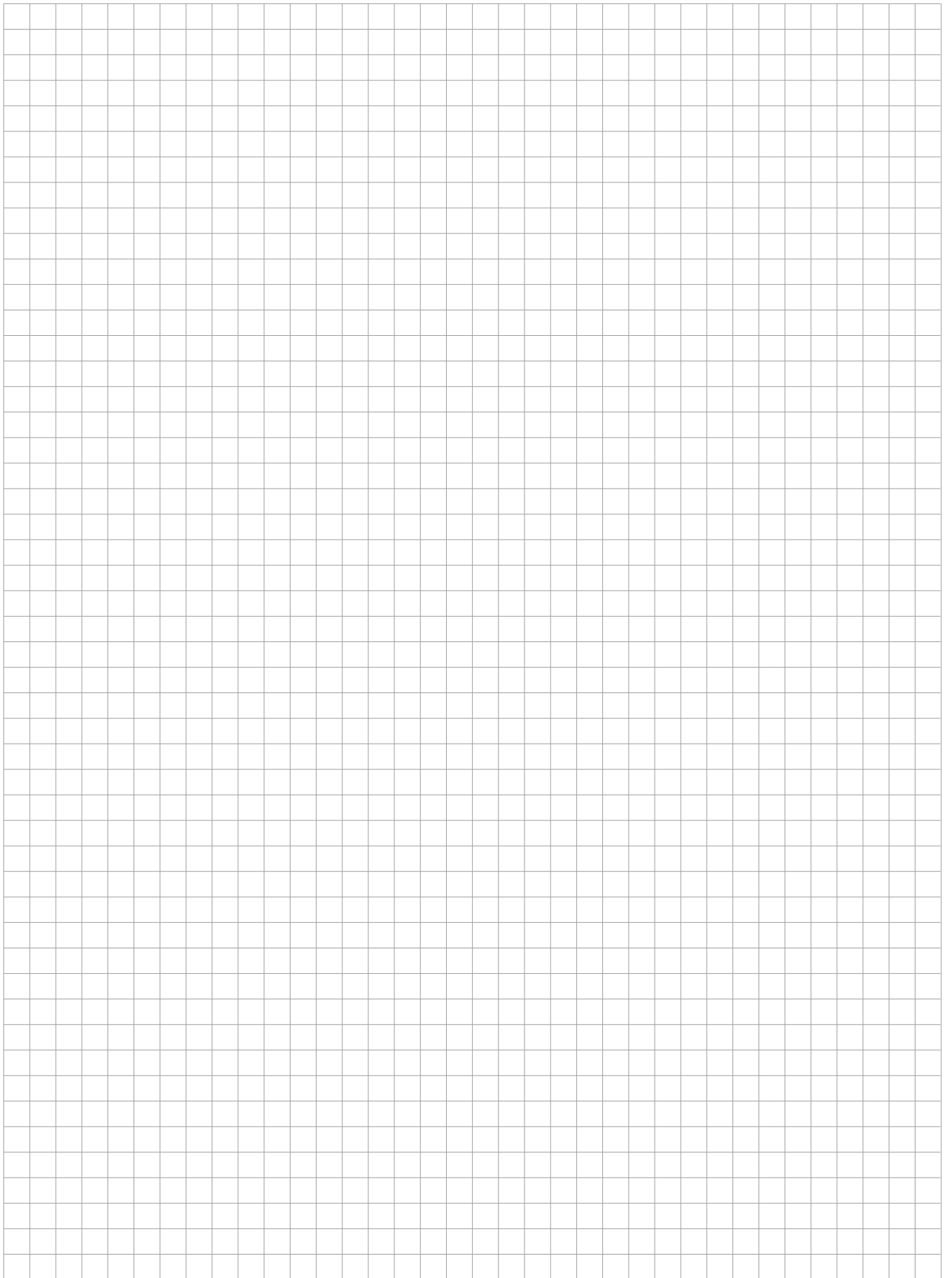



GENERAL INFORMATION



PAGE 134

8.1 TECHNICAL INFORMATION

8.2 APPLICATION EXAMPLES

PAGE 148

8.3 PRODUCT MATRIX

8.4 ORDER CODE

TECHNICAL INFORMATION

NADELLA TELESCOPIC SYSTEMS

Nadella telescopic slides are special ball bearing guides for high load rating. Two or more ball bearing mounted guide rails which can be drawn telescopic-wise guarantee a high reliability. According to the requirements a combination of different manufactured parts is used (rolled parts, cold-rolled steel and machined parts). Load and extension proportions are the basic characteristics of the telescopic slides. The model line is made up of five types and three extension proportions.

PART EXTENSIONS

extension length 50-70% of the assembly length

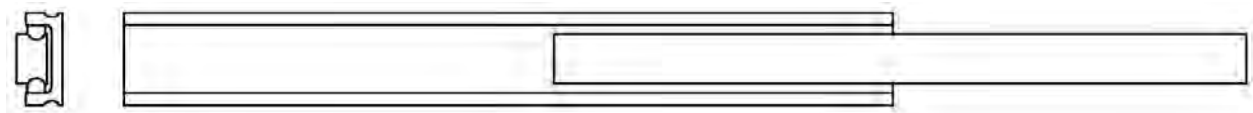

FULL EXTENSIONS

extension length 100% of the assembly length

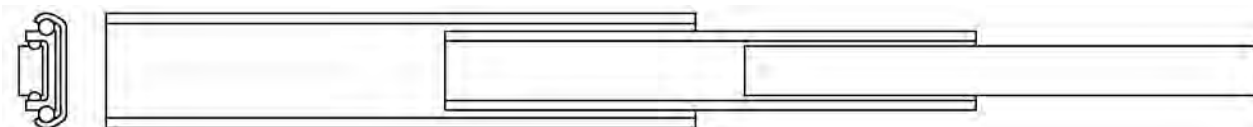

FULL EXTENSIONS IN Z DESIGN

extension length 100% of the assembly length

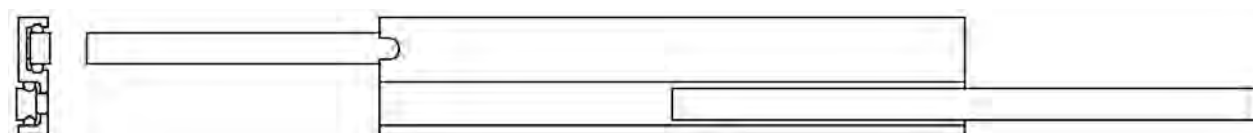

HEAVY DUTY EXTENSIONS

extension length 100% of the assembly length

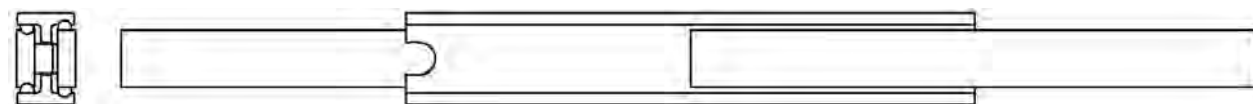

OVER EXTENSIONS

Extension length ca. 150 – 200% of the assembly length

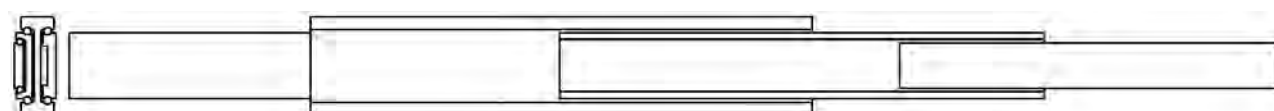

From these types numerous variations are derived in order to offer the ideal telescopic slide regards extension length, load magnitude and assembly. Further functions as forward / backward extension, special end stop dampers and lockings can supplementary be delivered.

Nadella aims to offer customized solutions with this product in a machine building quality. Telescopic slides are robust and need little maintenance for a long life. Economical solutions can be realized due to low supply costs and a simple assembly.

Nadella slides are linear guides with one or more carriages with re-circulation linear ball bearings running on a rail. Telescopic slides and guides are based on the same linear rails and can be combined with each other.

APPLICATIONS FOR NADELLA TELESCOPIC SLIDES

Nadella telescopic slides are used in many different areas, e.g. in the machine building, railcars, special vehicles for example in rescue vehicles, ship building or military vehicles, conveyor and storage techniques and many others. Telescopic slides are often used for battery boxes, handling and door systems, protection covers, switch cabinets, cashpoint (ATM) and other.

ASSEMBLY

An outer rail and one or more inner rails are the basic elements of the telescopic slides. As rolling element hardened balls are used which are kept in cages. With special chosen balls nearly zeroplay will be reached. A defined play for special enviromental conditions e.g. for high-temperature can be agreed. Standard end stops avoid an unintentional cutting of the different slide parts. All threads and fixing holes are easily accessible for assembly.

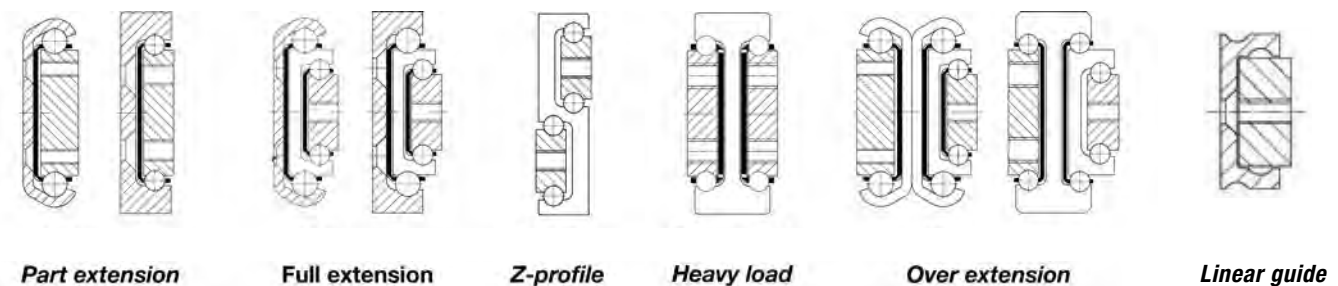

The standard mounting and extension lengths of each telescopic slide is shown in the dimension sheets. The standard lengths of many mounting sizes are divided into 50 and 100 mm steps. Special mounting lengths or special extensions can be provided upon customer's demand.

TECHNICAL INFORMATION

STANDARD LENGTHS' TOLERANCES

Installation length (mm)	≥ 150 < 420	≥ 420 < 1050	≥ 1050 < 2840
Tolerance (mm)	± 0,5	± 0,8	± 1,2

STEEL, STAINLESS STEEL (NX) AND ALUMINIUM (A)

Nadella telescopic rails are made of coil material or machined and drawn steel profiles. According to size and allowed load the most economic manufacturing process is used. All linear guides are surface coated and therefore effectively protected against corrosion. Alternatively, many telescopic slides can also be produced of stainless steel (NX variation) or aluminium (A).

STANDARD MATERIALS

The guides made of stainless steel (NX) have reduced basic load ratings (about 70%). The guides made of aluminium have a reduced weight and reach a basic load of about 30-40%.

	Guide rail	Cage	Ball
Standard	C45 (1.0503)	Steel coated	100Cr6 (1.3505)
Stainless steel (NX2/NX4)	NX2 load capacity -30% (1.4301) NX4 load capacity -40% (1.4571)	Stainless steel	X46Cr13 (1.4034)
Aluminium (A)	3.3206 EV1 -70%	Stainless steel	X46Cr13 (1.4034)

CORROSION PROTECTION THROUGH SURFACE TREATMENT

All Nadella telescopic slides are surface treated and are effectively protected against corrosion for many applications. Depending on demand, application case and surrounding condition different surface treatments are possible or stainless steel version (NX) is available. The resistance of the surface treatments varies from 240 up to more than 700 hrs.

As standard NC1 we offer the telescopic slides with free zinc coating (Fe/Zn8/Top-Coat) with thick-layer passivation acc. to RoHS. The surface is silver shining with a slight blue gleam.

Shortcut	Coating	RoHS	Salt bath spraytest
NC1	Zinc-thick layer passivation	yes	about 240 hrs.
NC4	Zinc nickel plated with passivation	yes	over 700 hrs.

ADDITIONAL FUNCTIONS AND SPECIAL EQUIPMENTS

FORWARD AND BACKWARD EXTENSION (VR, VRM)

Many systems of the part and full extensions can be delivered as forward and backward extension.

The inner rails of full extensions in 3 parts can be controllably shifted through carriers (VRM). The advantage is a higher security because the unintentional moving of the middle rail of the backward extension can be prevented. The loads at the end of a telescopic slide can be better adopted with an optimum distribution of the rails.

END STOPS AND DAMPERS (EDG, FDOG)

End stops are standardized equipment for all telescopic slides. Furthermore special dampers can be provided for numerous extensions. There is the possibility to choose between simple cheap plastic or elastomer dampers – fixed directly at the end – or special spring dampers.

CATCHES (EHG, EHO, EOG) OR LOCKINGS (VO, VG, VOG)

Lockings are strong fixings via spring pieces which guarantee that a self movement of the extensions can effectively be prevented.

Catches are form fit fixing devices which fix the extensions with bolts or spring locks in their end positions. Without opening the spring lock none of the slides can move. This application is chosen for person and material safety reasons.

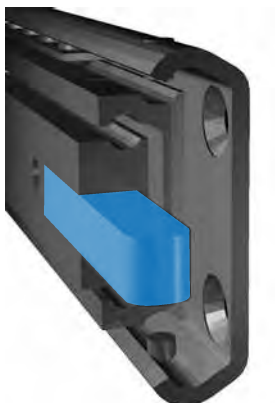
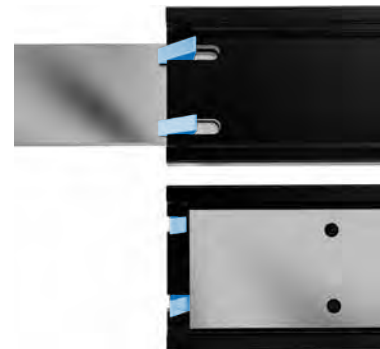

LOCKING



LOCKING PIN



VRM CARRIER

TECHNICAL INFORMATION

READY MADE COMPLETE SOLUTIONS

For special applications ready for installation complete solutions can be realized taking into account the economic lot size. These systems can be built out of telescopic rails with customized frame, end dampers, end stops or lockings and more.

CHOICE AND VARIATIONS OF TELESCOPIC SLIDES

Nadella telescopic slides are preferential made for static applications with lower dynamic. They are ideal because of their unhardened tracks and the robust and rigid body for high loads which must be moved from time to time, but they are also ideal for constant movements with lower dynamic.

GENERAL BASIC CONDITIONS:

- Pair wise operation
- Vertical installation position
- Center of gravity of load in the middle between telescopic slide pairs
- Center of gravity of load in the middle of the rail drawers
- Permissible loads can only be reached when using all standard fixing points

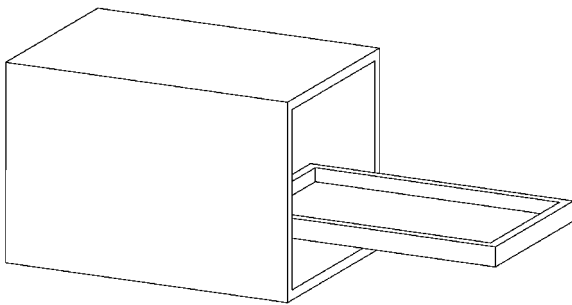

Standard application: Drawer extension telescopic rails vertical.

With horizontally installed telescopic rails up to 50 % of the allowed loads can be used depending on the type of rail. Besides the deflection will be significantly higher. Therefore a horizontally installation is recommended for a limited extend only when using small rails or extensions more than 600 mm.

If this is the case, please contact Nadella's technical service for additional information.



SPRING DEFLECTION

Spring deflection means the deflection of the full telescopic guide under maximum load. Telescopic rails which are correctly installed and with equally divided load between the extension pairs only have a very low deflection because of their rigid body. The standard telescopic rails have a spring deflection of approx. 1 % with the maximum use of the load, pair wise use and radial load (vertically mounted). For any application with tangential load or horizontal installations, please contact Nadella's technical service.

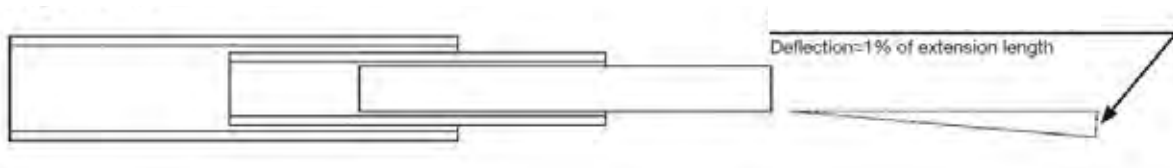

DYNAMIC AND LIFETIME

Telescopic rails are mainly aimed for static applications. The average speed with greased tracks are said to be up to 0,5 m/sec.

Higher speed or continuous operation or more than 10 strokes/min will negatively influence the lifetime. If higher dynamics are required you should use a bigger oversized guide rail and a reduced lubrication interval. You have also the possibility to use telescopic rails with nitrided surface. The standard operation temperature is between +10°C and +80°C, but depending on the application, the temperature range can be higher up to 300°C. In this case, adaptations must be made regards bearing air and eventually surface coating and special high temperature lubricants are necessary.

INSTALLATION OF TELESCOPIC RAILS

The telescopic rails with nearly zero play must be mounted parallel and angled for a perfect operation. All fixing holes and/or threads should be used for an optimum use of load.

Screws only with a strength grade of at least 8.8 should be used for assembly and to be fixed according to the screw producer's guidelines. Under certain circumstances the guide rails can be equipped with increased bearing air and can be mounted with a slight stroke.

TECHNICAL INFORMATION

MAINTENANCE AND LUBRICATION

All Nadella telescopic slides and guide rails are extremely maintenance free. Standard rails are delivered fully installed and greased. Rails made of stainless steel or aluminium will be delivered ungreased.

Depending on the surrounding conditions they should be checked from time to time, dirt should be removed and “dry” rails should be regreased. This prevents friction, protects the assembly parts and provides a long life. The regreasing term is variable and should be calculated regards use conditions such as load, travel conditions, temperature, dirt etc..

The ball cages of the telescopic slides are not restraint-guided, consequently the cage can move. In this case the end positions have to be reset.

NOTES

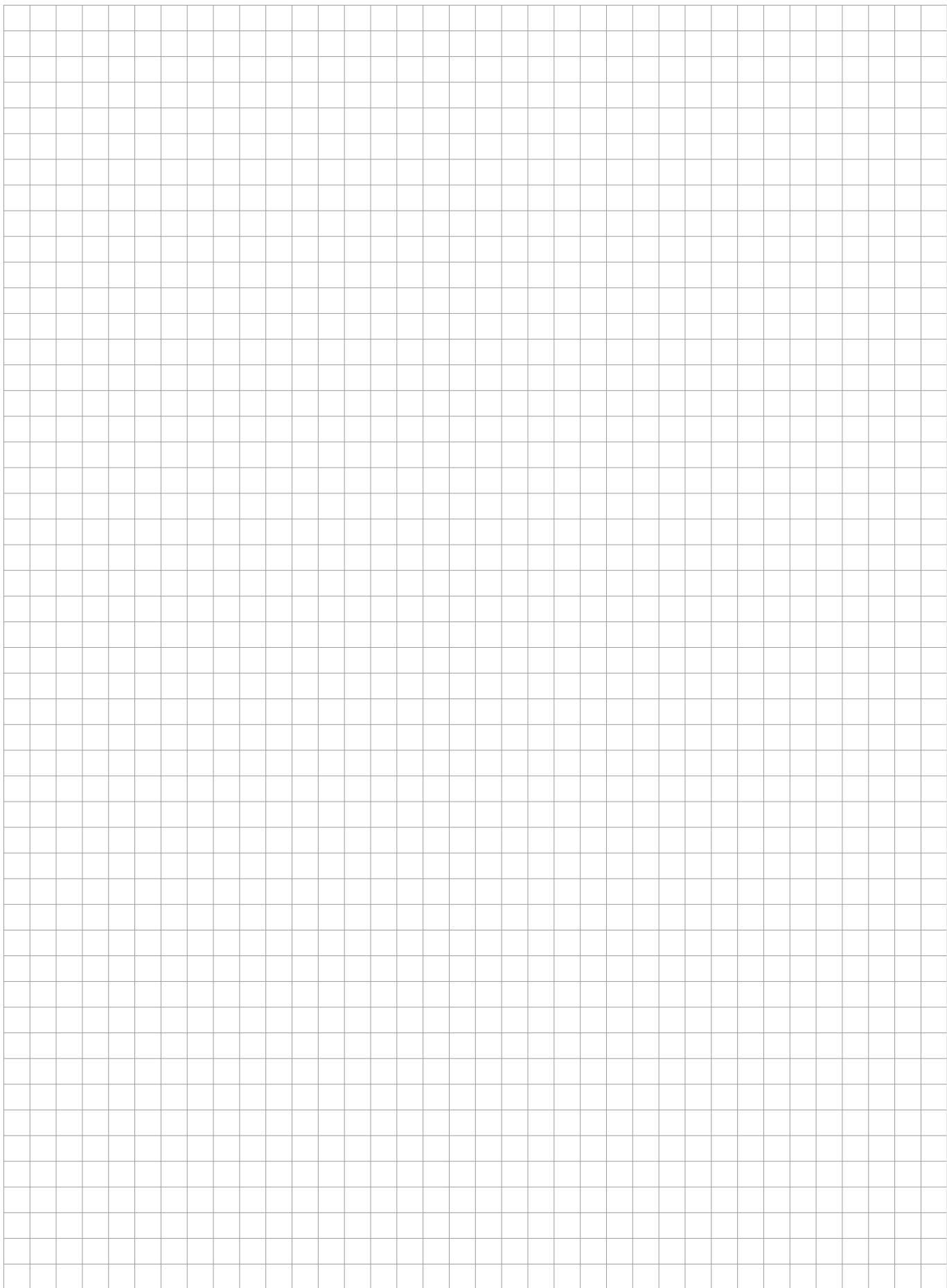

APPLICATION EXAMPLE

Application	Protective equipment
Industry	Rubber- and plastics machines Machinetools
Products	Full-extension (NTV)

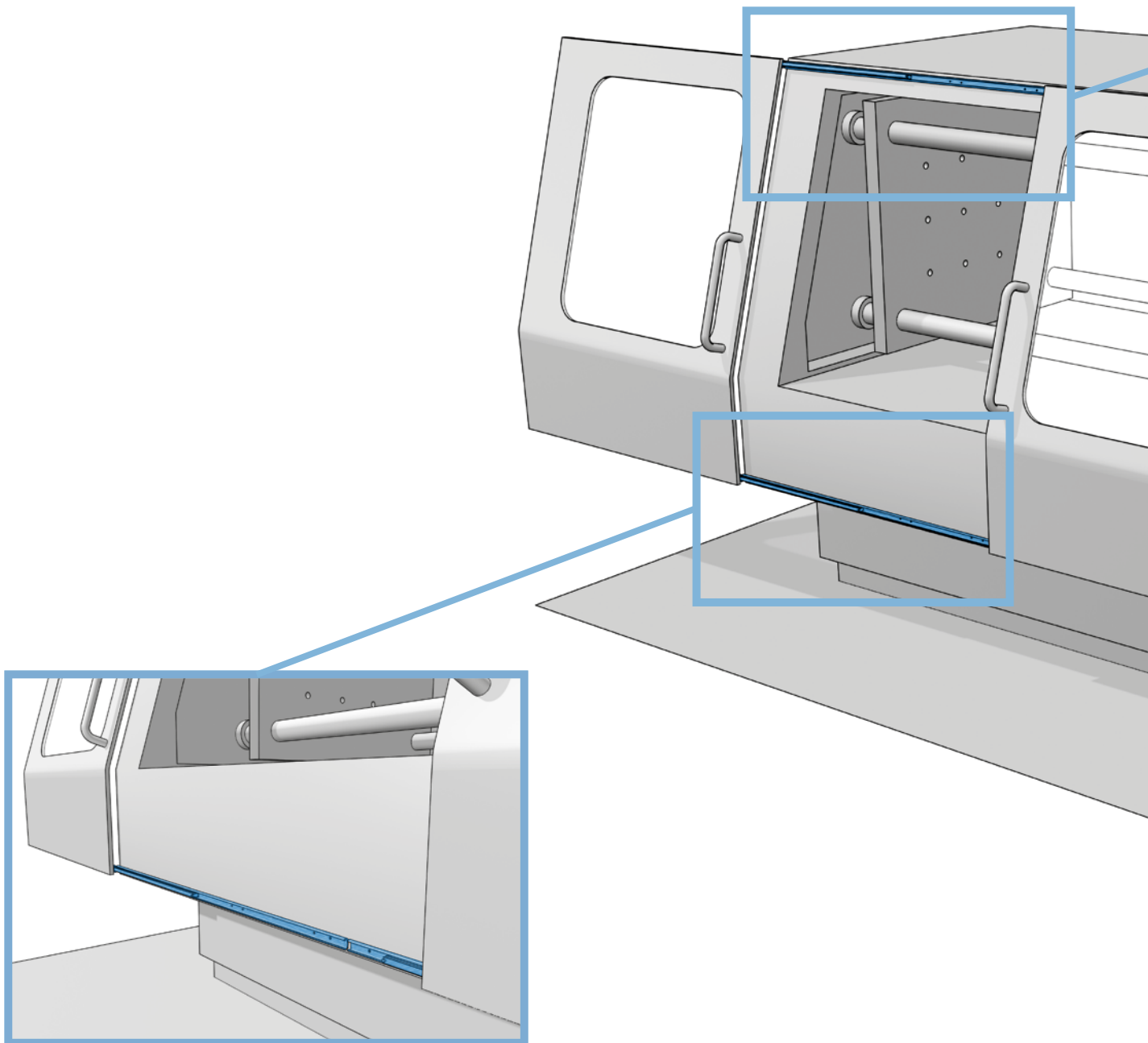

8.2

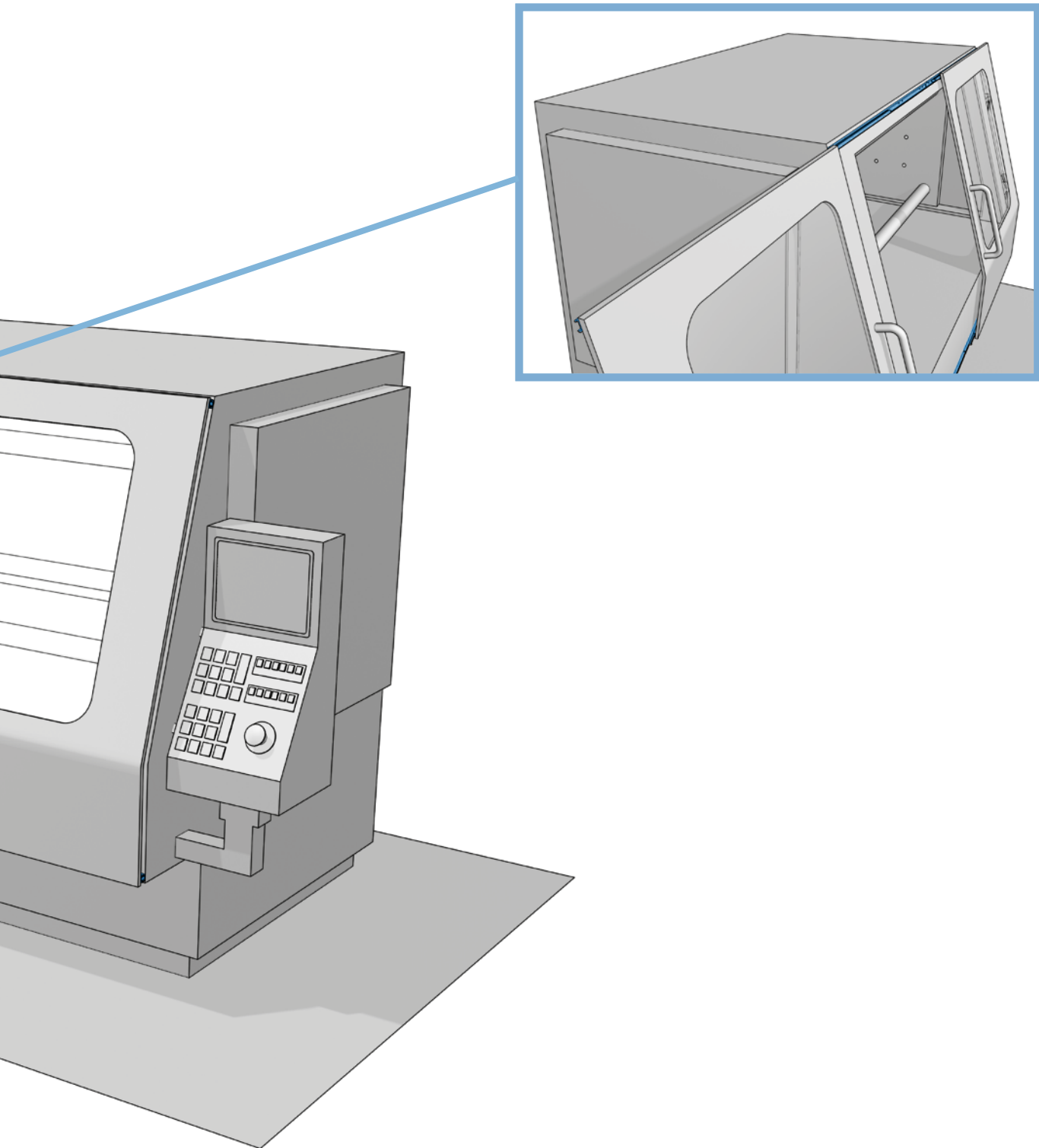

APPLICATION EXAMPLE

Application	Product supply
Industry	Medical technology, semi-conductor technology, etc.
Products	Full-extension (NTV)

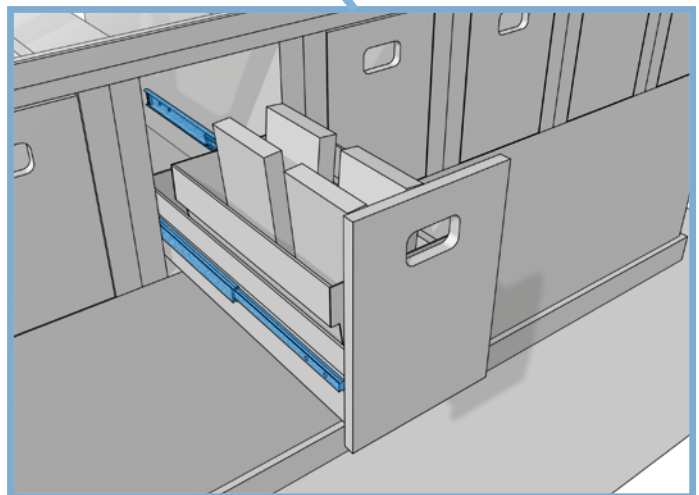
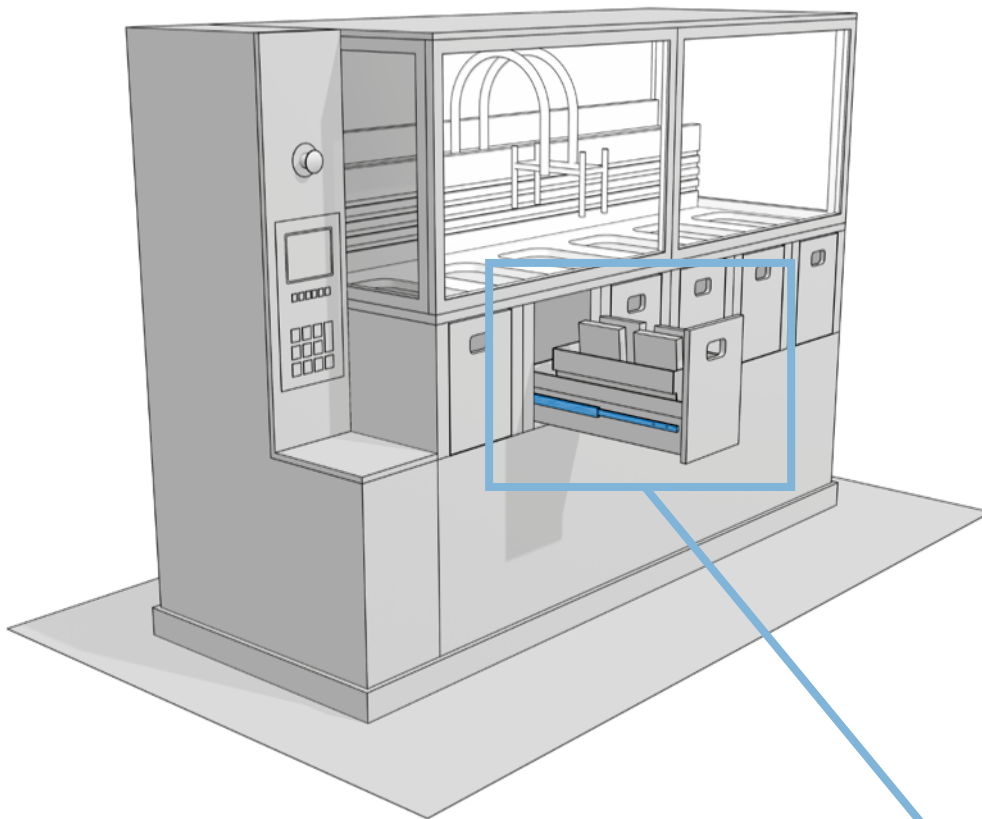

Application	Component magazine
Industry	Warehouse and logistics.
Products	Full-extension (NTV)

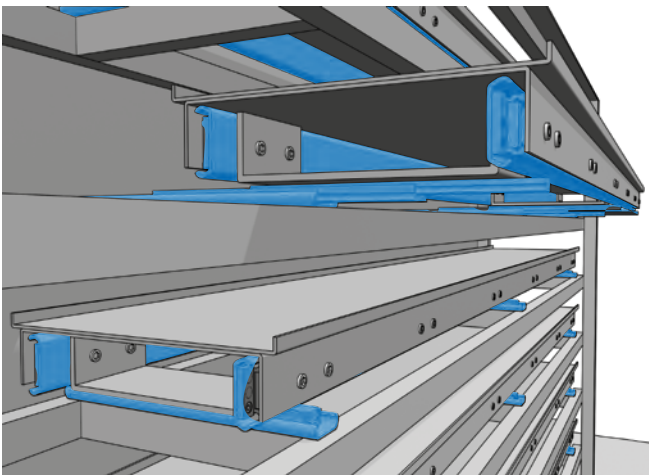
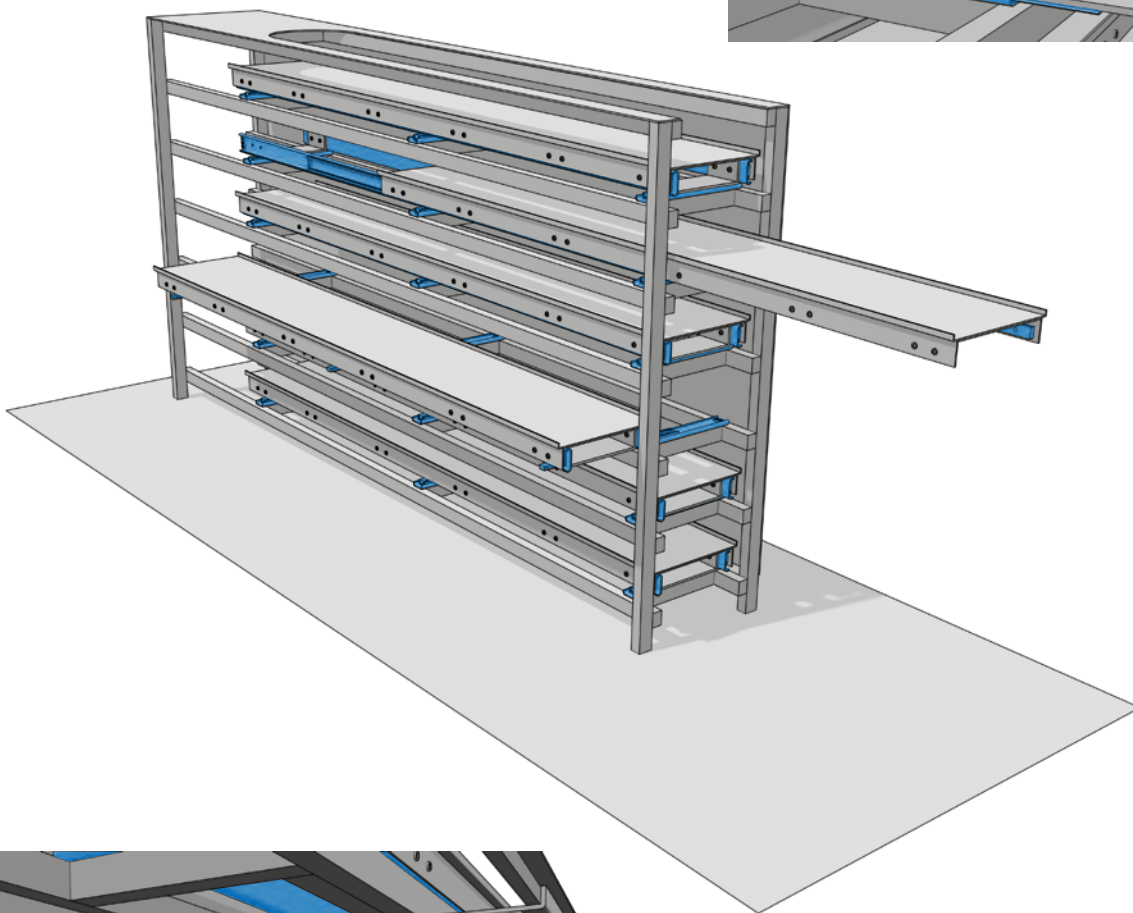
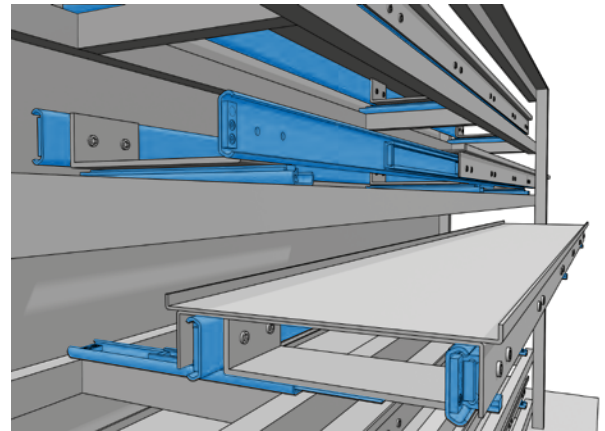

APPLICATION EXAMPLE

Application	Battery move-out / Door rail guide
Industry	Railway technology
Products	Full Extension Z-Steel Basic Profile (NTVZ)

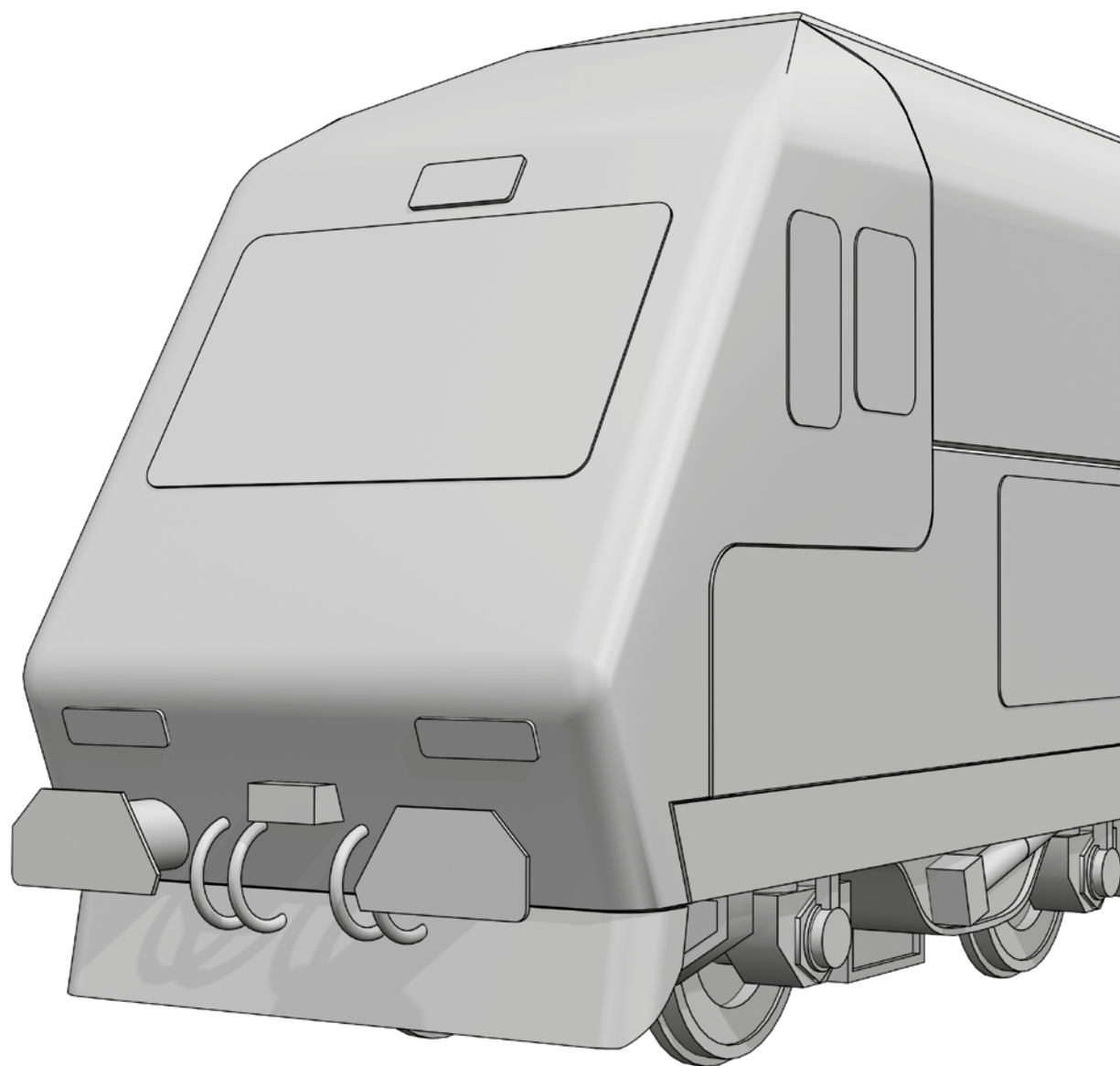

8.2

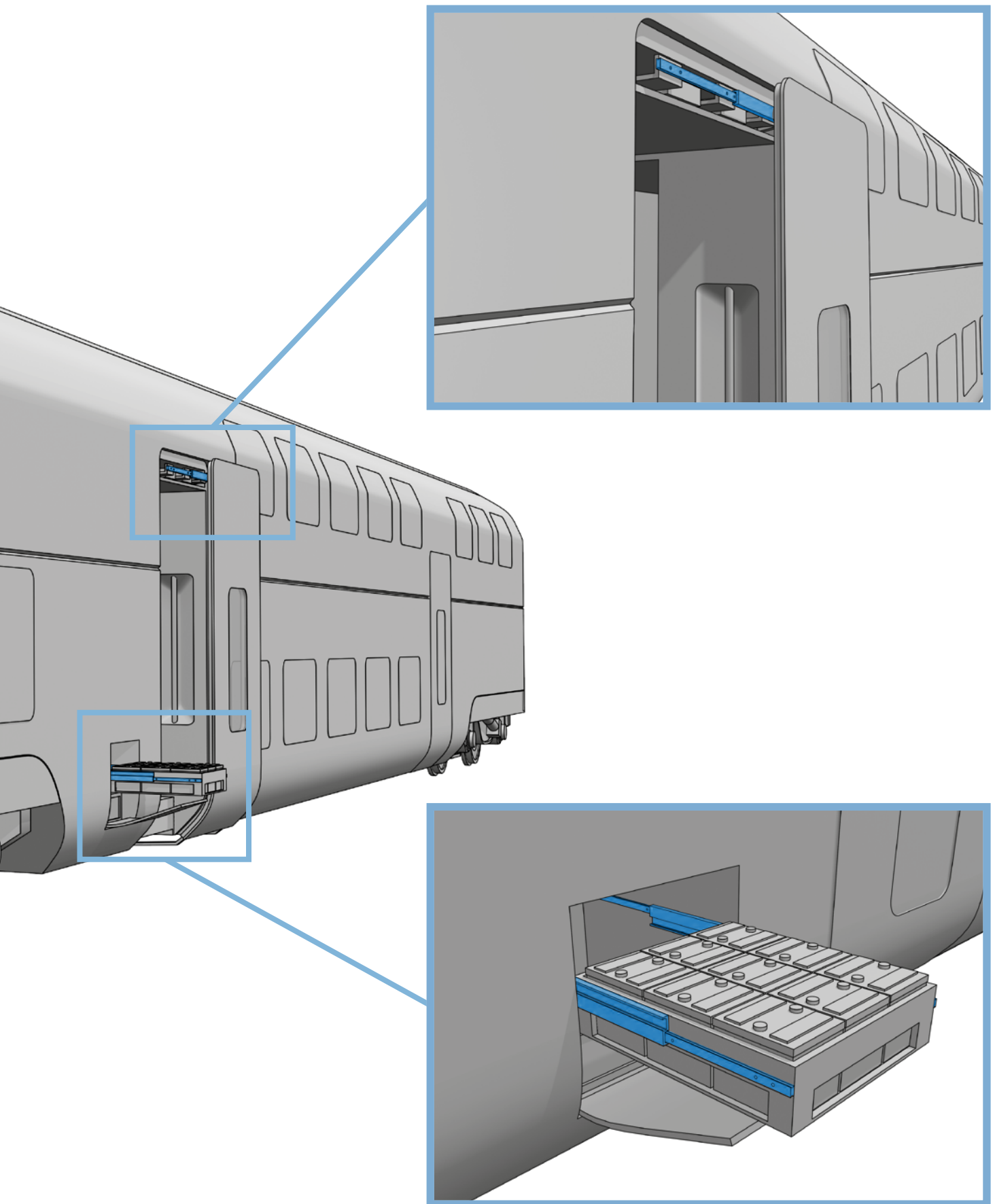

PRODUCT MATRIX

Product group	Designation	Technical Manual				Material				Options											
		E from	E to	Extension length	Load (N)	ST	NX2	NX4	A	VG	VO	VOG	EHG	EHO	EOG	EDG	KK	NC4	FDOG	VR	VRM
Part Extension	NTA27-14T	200	1500	~ 60%	190-710	x										x	x	x		x	
	NTA33-15	200	1500	~ 60%	190-1200	x							x	x	x	x	x	x		x	
	NTA40-18.5	200	1750	~ 60%	500-2550	x	x	x	x				x	x	x	x	x	x		x	
	NTA48-15T	250	1500	~ 60%	400-1800	x				x	x	x	x	x	x	x	x	x		x	
	NTA50-19.5	200	2000	~ 60%	500-2900	x	x	x	x	x	x	x	x	x	x	x	x	x		x	
	NTA59-17.5T	250	1750	~ 60%	500-2550	x				x	x	x	x	x	x	x	x	x		x	
	NTA60-20	250	2000	~ 60%	1000-3400	x	x	x	x	x	x	x	x	x	x	x	x	x		x	
	NTA70-21	300	2250	~ 60%	1000-4200	x	x	x	x	x	x	x	x	x	x	x	x	x		x	
	NTA72-21.5T	350	2000	~ 60%	500-3050	x				x	x	x	x	x	x	x	x	x		x	
	NTA80-22	350	2500	~ 60%	750-5000	x	x	x	x	x	x	x	x	x	x	x	x	x		x	
	NTA100-26	350	2750	~ 60%	1500-10000	x	x	x	x	x	x	x				x	x	x		x	
	NTA120-31	400	2750	~ 60%	1650-12000	x	x	x	x	x	x	x				x	x	x		x	
NTA150-35	500	3000	~ 60%	2000-15500	x	x	x	x	x	x	x				x	x	x		x		
Full Extension	NTV27-26T	200	1300	~100%	700-1200	x										x	x	x		x	
	NTV27-28DC	200	1000	~100%	300-800	x											x	x		x	
	NTV48-20T	200	1500	~100%	500-1300	x				x			x	x	x	x	x	x		x	
	NTV48-22T	200	1500	~100%	410-1510	x				x	x	x	x	x	x	x	x	x		x	
	NTV48-30DC	250	1600	~100%	710-1910	x							x	x	x	x	x	x		x	
	NTV59-24T	300	2000	~100%	750-2200	x				x	x	x	x	x	x	x	x	x		x	x
	NTV59-35DC	300	2000	~100%	750-2700	x							x	x	x	x	x	x		x	
	NTV60-26	300	2000	~100%	800-2900	x	x	x	x	x	x	x	x	x	x	x	x	x		x	x
	NTV72-26T	300	2000	~100%	1400-3400	x				x	x	x	x	x	x	x	x	x		x	x
	NTV72-43DC	300	2000	~100%	1600-3900	x				x	x	x	x	x	x	x	x	x		x	
	NTV80-27.5	500	2250	~100%	1250-4450	x	x	x	x	x	x	x	x	x	x	x	x	x		x	x
	NTV100-34	500	2500	~100%	1250-5750	x	x	x	x	x	x	x					x	x		x	x
	NTVZ45-14	250	800	~100%	250-450	x			x								x	x			
	NTVZ60-17	250	1000	~100%	650-1400	x			x								x	x			
	NTVZ80-22	250	1000	~100%	1500-2450	x			x								x	x			
	NTVZ100-24	350	1500	~100%	1600-3600	x			x								x	x			
	NTVZ120-28	400	1500	~100%	2100-5500	x			x								x	x			
NTVZ150-30	400	1500	~100%	3650-7400	x			x								x	x				
Heavy Duty Extension	NTS30-26	200	1500	~100%	300-1200		x	x	x							x	x	x		x	x
	NTS33-30	200	1750	~100%	300-1300	x							x	x	x	x	x	x		x	x
	NTS33-34	200	1750	~100%	350-1350	x							x	x	x	x	x	x		x	x
	NTS35-30	200	2000	~100%	200-1400		x	x	x				x	x	x	x	x	x		x	x
	NTS40-26	250	1500	~100%	400-1600	x	x	x	x							x	x	x		x	x
	NTS50-30	250	2000	~100%	400-2800	x	x	x	x				x	x	x		x	x	x	x	x
	NTS60-32	250	2250	~100%	500-5500	x	x	x	x	x	x	x	x	x	x		x	x	x	x	x
	NTS70-36	300	2500	~100%	650-7400	x	x	x	x	x	x	x	x	x	x		x	x	x	x	x
	NTS80-36	300	3000	~100%	1000-9350	x	x	x	x	x	x	x	x	x	x		x	x	x	x	x
	NTS100-44	500	3000	~100%	1300-11000	x	x	x	x	x	x	x					x	x	x	x	x
	NTS120-44	500	3000	~100%	1500-11800	x	x	x		x	x	x					x	x	x	x	x
	NTS150-56	500	3000	~100%	2000-13900	x	x	x		x	x	x					x	x	x	x	x
	NTS200-72	700	3000	~100%	2500-17500	x	x			x	x	x					x	x	x	x	x
	NTS250-74	700	3000	~100%	3000-20000	x				x	x	x					x	x	x	x	x
NTS250-104	750	3000	~100%	7000-30000	x				x	x	x					x	x	x	x	x	

8.3

Product group	Designation	Technical Manual				Material				Options											
		E from	E to	Extension length	Load (N)	ST	NX2	NX4	Al	VG	VO	VOG	EHG	EHO	EOG	EDG	KK	NC4	FDOG	VR	VRM
Over Extension	NTSU40-52DS	300	1200	~200%	400-800	x	x	x	x								x	x			
	NTU48-35DC	250	1200	~150%	300-750	x							x	x	x	x	x	x			
	NTSU50-60DS	300	1500	~200%	700-2100	x	x	x	x								x	x			
	NTU59-41.5DC	250	1500	~150%	700-2000	x				x			x	x	x	x	x	x			
	NTSU60-40	300	1500	~150%	1500-2700	x	x	x	x	x			x	x	x	x	x	x			x
	NTSU60-68DS	300	1500	~200%	2830-7250	x	x		x	x							x	x	x	x	
	NTU72-30T	300	1500	~150%	300-1550	x				x	x	x	x	x	x	x	x	x			x
	NTU72-47.5DC	300	1750	~150%	1000-2700	x				x			x	x	x		x	x			
	NTSU80-43	400	2000	~150%	1000-3300	x	x	x	x	x			x	x	x		x	x			x
	NTSU80-79DS	400	2000	~200%	3000-11320	x	x		x	x							x	x	x	x	
	NTSU100-51	500	2250	~150%	1000-5600	x	x	x	x	x							x	x			x
	NTSU100-98DS	500	2000	~200%	4000-14000	x	x		x	x							x	x	x	x	
NTSU150-64	500	2500	~150%	1500-7600	x	x	x	x								x	x			x	
Linear guides	NTSF33	150	∞*	x	800-2600	x										x	x	x			
	NTSF40	150	∞*	x	2300-3400	x			x							x	x	x			
	NTSF50	200	∞*	x	3000-4500	x			x							x	x	x			
	NTSF60	250	∞*	x	3500-5250	x			x							x	x	x			
	NTSF80	250	∞*	x	4000-6000	x			x							x	x	x			
	NTSF100	250	∞*	x	6500-10000	x			x							x	x	x			
	NTSF150	250	∞*	x	9000-14000	x			x								x	x			

Legend

E	Installation length
ST	Steel
NX2	1.4301
NX4	1.4571
Al	Aluminum
VG	Locking, closed rail
VO	Locking extended rail
VOG	Locking double-sided
EHG	Catch, closed rail
EHO	Catch extended rail
EOG	Damper, closed rail
EDG	Damper, closed rail
KK	Balls and cage stainless steel (standard for NX-rails)
NC4	NC4 = Zinc-nickel plated
FDOG	Spring damping, extended and closed rail
VR	Forward and backward extension
VRM	Forward and backward extension including carrier for inner rail
*	Infinite total length Single rails max. 2500 mm Dovetail connections

ORDER CODE / OPTIONS

For some types several options possible.
Available options depending on type or size.

NTV 48-22 T - 1000 - XX

RAIL TYPE

NTA
NTV
NTVZ
NTS
NTU
NTSU

INSTALLATION SIZE

ADDITION FOR SOME TYPES

T = Sheetrail
DC = Back-to-back assembly
DS = 2 x I-beam (200% extension)

INSTALLATION LENGTH

OPTIONS

AI = Aluminum
SB = Standard hole pattern (not required)
NZ = Design acc. drawing (e.g: customised hole pattern)
KK = Balls and cage stainless steel (standard for NX- and A-rails)
NC1 = Zinc-thick layer passivation (standard)
NC4 = Zinc-nickel plated
NC5 = Standard steel without coating
NX2 = Stainless Steel Rail A2 Mat. 1.4301 (Load - 30%)
NX4 = Stainless Steel Rail A4 Mat. 1.4571 (Load - 40%)
EHG = Catch retracted rail
EHO = Catch extended rail
EOG = Catch double sided
VG = Locking retracted rail
VO = Locking extended rail
VOG = Locking open and closed
EDG = Damper, closed
FDOG = Spring damper, open + closed
VR = Forward and backward extension
VRM = Forward and backward extension including carrier for inner rail
AZ = Special extension length (not necessary for standard version) Example: NTV48-22T-1000-AZ1080 = Extension length 1080 mm
LL = Smooth-running, for temperature up to 200°C or vertical installation
LS = Increasing clearance, for temperature > 200°C
G = Hardened

ORDER CODE LINEAR GUIDE SYSTEM

NTSF 50 - 2 - 120 - 2000

RAIL TYPE

INSTALLATION SIZE

NUMBER OF CARRIAGES

Standard = 1 carriage (not necessary for standard version)

CARRIAGE LENGTH

RAIL LENGTH



BIBUS SK, s.r.o
Trnavská 31, 94901 Nitra
Tel.: 037/ 7777 911
Fax.: 037/ 7777 999
sale@bibus.sk
www.bibus.sk

NADELLA S.r.l.
Italy
Via Melette, 16
20128 Milano

Tel.: +39 02 27 093 297
Fax: +39 02 25 51 768
customer.service@nadella.it

www.nadella.it

NADELLA GmbH
Germany
Rudolf-Diesel-Str. 28
71154 Nufringen

Tel.: +49 7032 9540-0
Fax: +49 7032 9540-25
info@nadella.de

www.nadella.de

NADELLA Linear Shanghai Co. Ltd.
China
No. 3456 South Pudong Road –
Shanghai 200125

Tel.: +86 21 5068 3835
Fax: +86 21 5038 7725
info@nadella.cn.com

www.nadella.cn.com

NADELLA Inc.
USA
14115 – 63 Way North
Clearwater – Florida 33760-3621

Toll free: +1 844-537-0330
Fax: +1 844-537-0331
info@nadella.com

www.nadella.com

NADELLA
France

service.client@nadella.fr

www.nadella.fr



Version 11/2017 - fmk. | fmk-web.de
Printed in Germany.
Errors and omissions excepted.

TL171EN