

moviroll

BATTERY ROLL PUSHERS



MORE PRODUCTIVITY, HIGHER SAFETY LEVEL

Moviroll roll pushers improve the productivity and increase the safety level as they allow the operator to effortlessly and safely maneuver both large and small cylindrical loads. Moviroll reduces risks for the operator according to the Technical Standards ISO 11228 "Ergonomics Manual handling".

They are ideal to move paper and cardboard rolls, but they are also used to move loads in several other industrial applications.

Battery roll pushers offer the advantage of free movement without the constraints of the pneumatic connections or electrical cables. They are powered by high performance and plug&play 24 V or 48 V lithium battery.

VARIABLE SPEED

to suit any operator needs

OVERSIZED WHEELS

to easily overcome any obstacles along the way

PLUG&PLAY BATTERY

the plug&play eco-friendly lithium battery allows one-handed changes in less than 10 seconds

STATUS DISPLAY

easily see power applied and battery charge percentage during usage

CUT FRAMES

for an easy removal of the roller and roller bearings

2 YEAR WARRANTY

the only product in its category with a 2-year warranty on both the motor and the battery

MRE XS

MRE XS is compact and handy but heavy duty at the same time. It's the best solution when the need of separating two rolls arises. The handle can be mounted at two heights from the ground, 850 or 920 mm.

BIBUS
SUPPORTING YOUR SUCCESS

BIBUS SK, s.r.o
Trnavská 31, SK-94 901 Nitra

Tel.: 037/ 7777 911 Email: sale@bibus.sk
Fax.: 037/ 7777 999 http://www.bibus.sk

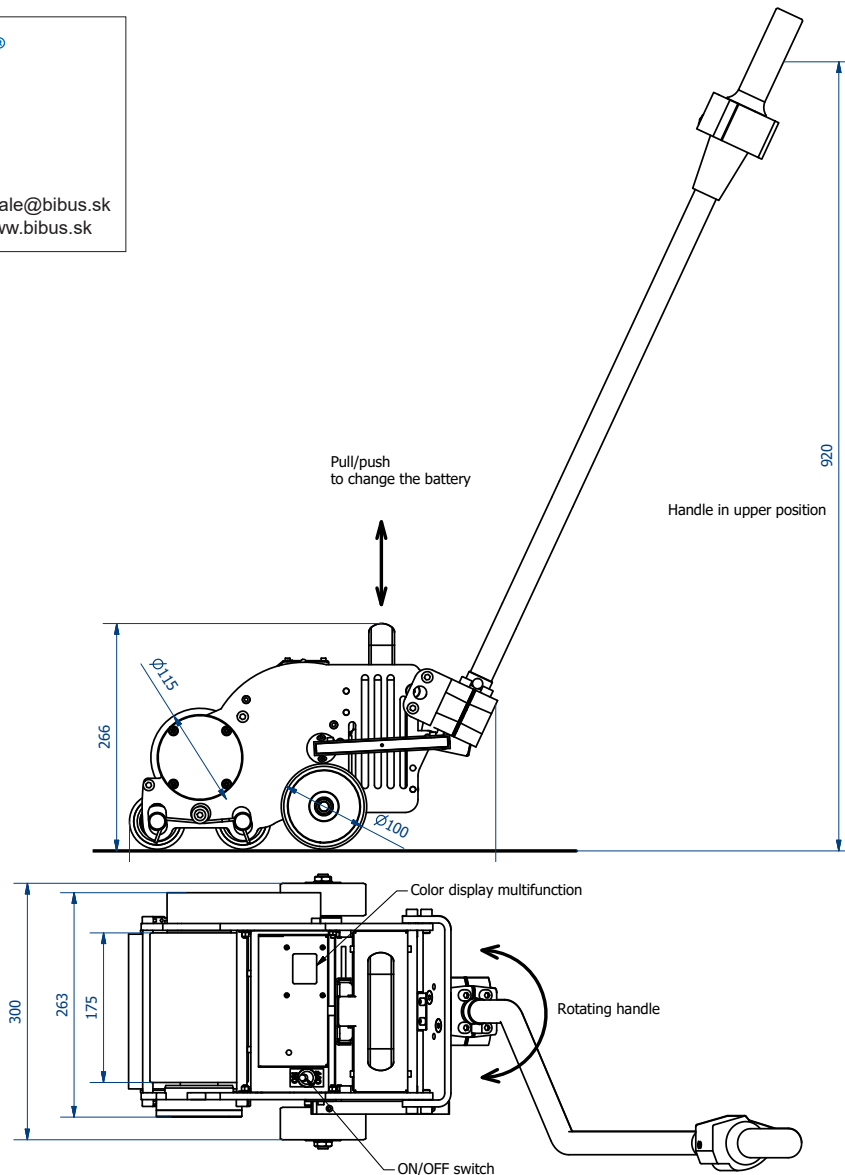

model	thrust force	lift force	max rolls diameter	motor	battery	max speed	unit weight
MRE 100 XS	12000 kg	3000 kg	2100 mm	48 V DC IP 44 brushless	lithium 48 V	13 m/min	30 kg
MRE 200 XS	16000 kg	4000 kg	2100 mm	48 V DC IP 44 brushless	lithium 48 V	9 m/min	30 kg
MRE 300 XS	20000 kg	5000 kg	2100 mm	48 V DC IP 44 brushless	lithium 48 V	7 m/min	30 kg