

HOSCH TRACKER ROLLER

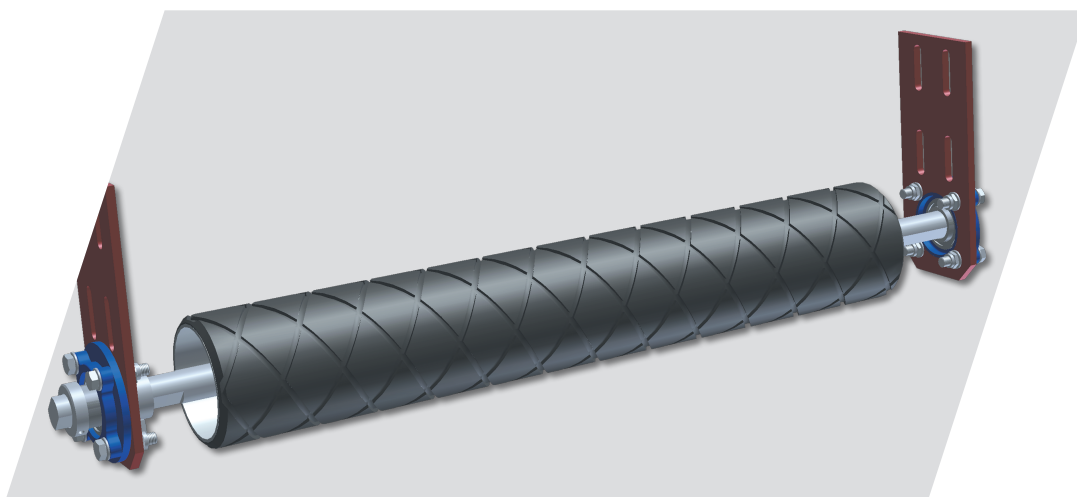

TYPE **R1/RG1**

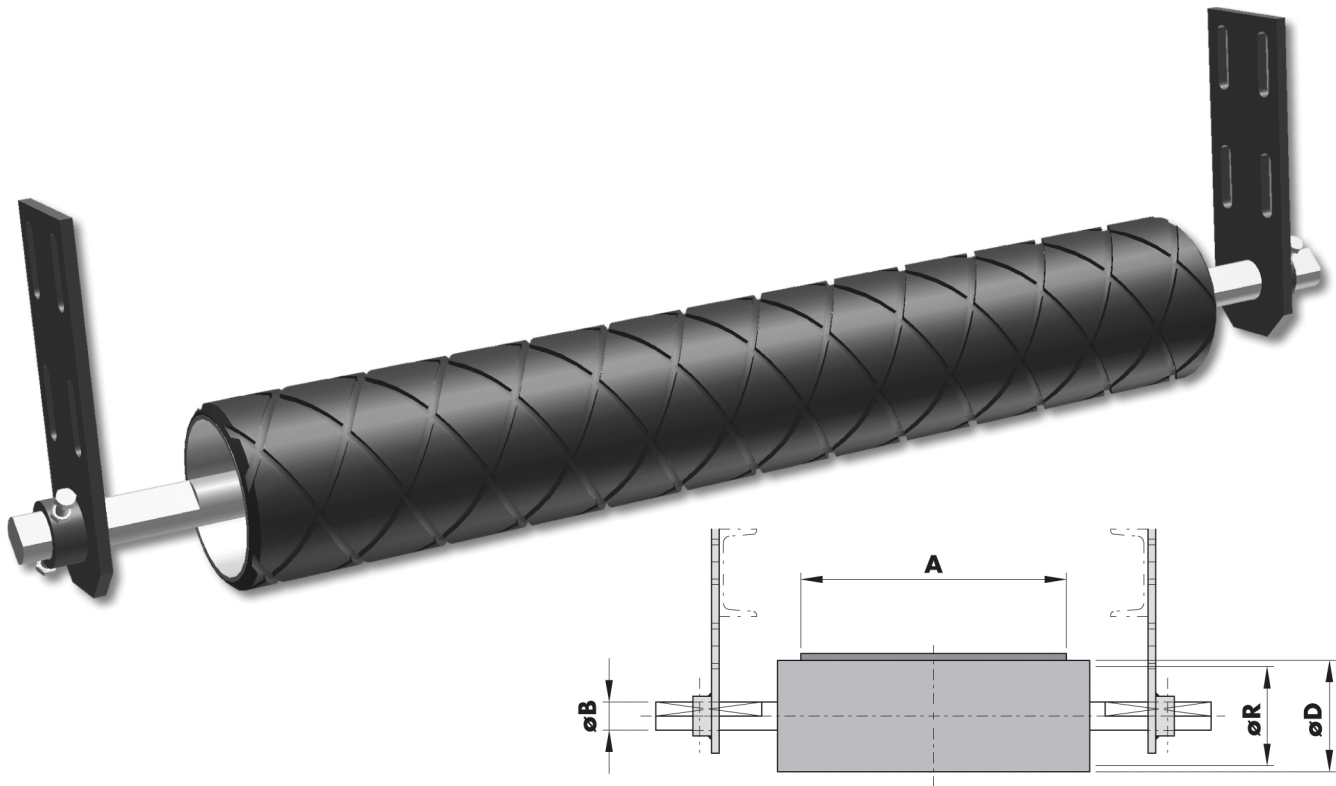

Advantages

- Maintenance free
- No wearing parts
- Durable rubber surface
- Suitable for all environmental conditions
- Minimum space required, compact dimensions
- Ease of installation
- Minimum of installation
- Also suitable for reversing operation, ideal for retrofitting

Belt width	Normal operation	Reversible operation	Dimensions [mm]		
A [mm]	Type	Type	øD	øR	øB
400	R1-40	RR1-40	175	159	45
500	R1-50	RR1-50			
650	R1-65	RR1-65			
800	R1-80	RR1-80			
1000	R1-100	RR1-100			
1200	R1-120	RR1-120	210	193,7	55
1200	RG1-120	RRG1-120			
1400	RG1-140	RRG1-140			
1600	RG1-160	RRG1-160			
1800	RG1-180	RRG1-180			
2000	RG1-200	RRG1-200			

Tracker Rollers from **HOSCH**
ensure conveyor belt alignment.

BIBUS[®]
SUPPORTING YOUR SUCCESS

BIBUS SK, s.r.o
Trnavská 31, SK-94 901 Nitra

Tel.: 037/ 7777 911 Email: sale@bibus.sk
Fax.: 037/ 7777 999 http://www.bibus.sk