

# **HOSCH HEAD- PULLEY SCRAPERS**

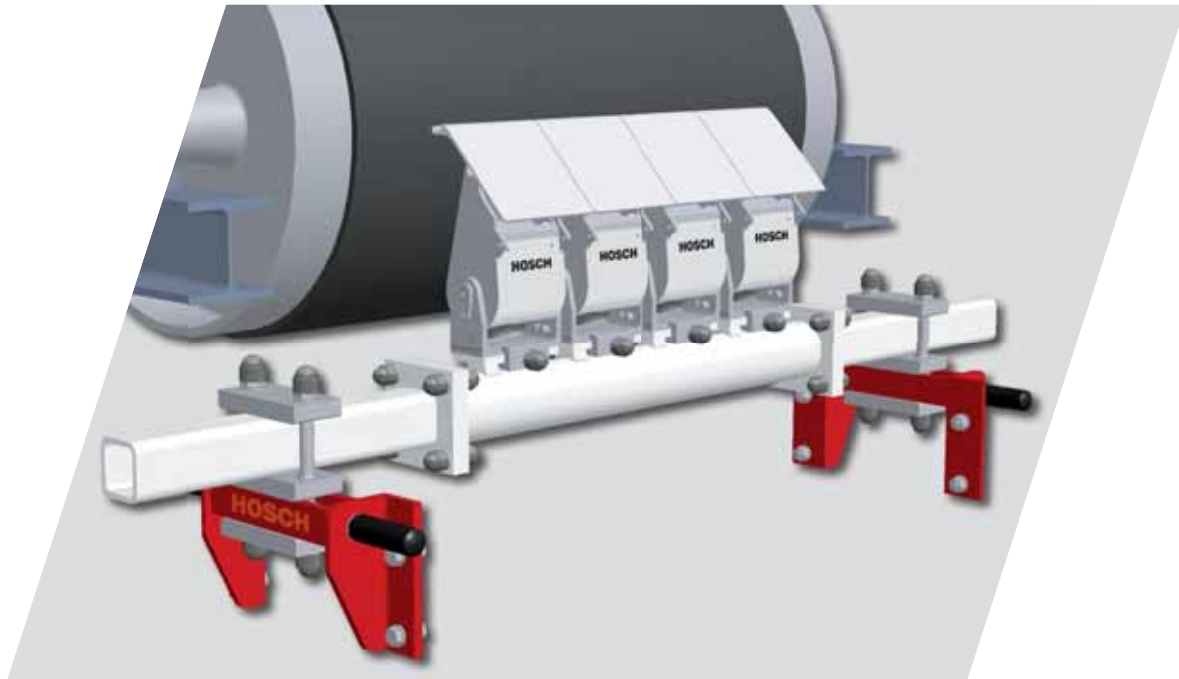

TYPE **HDO2**

# HOSCH Head-Pulley Scraper Type HD02

A great innovative advance in primary scraper technology to be used on discharge or head pulleys. Conveyor belt systems transporting extremely sticky, muddy or difficult material presents a big challenge to belt cleaning equipment.

For these special operating conditions **HOSCH** have developed the Head-Pulley Scraper **Type HD02**:

- Extremely robust scraper system that is installed at the 3 o'clock position on the pulley.
- Suitable even for the most difficult bulk material.
- Unique deflection function of cleaning modules in case of obstructions or damage to the belt surface. As a result the conveyor belt and scraper are protected against further damage.
- Tungsten carbide tipped cleaning blades provide efficient cleaning and very long life
- No further adjustment is required until the blades are worn. The system is almost maintenance free.
- Easy installation on any kind of discharge or head pulley.

## HOSCH Service

The **HOSCH Service** is available worldwide and provides the following technical support:

- Technical analysis of your conveyor belt systems
- Selection of suitable belt cleaning and belt tracking systems
- OEM support and CAD supported installation drawings
- Installation, maintenance and service of **HOSCH systems**
- Technical support by follow up belt plans and service statistics
- Spare parts management
- Calculations of economic efficiency and profitability

## Characteristics of the HOSCH Head-Pulley Scraper Type HD02

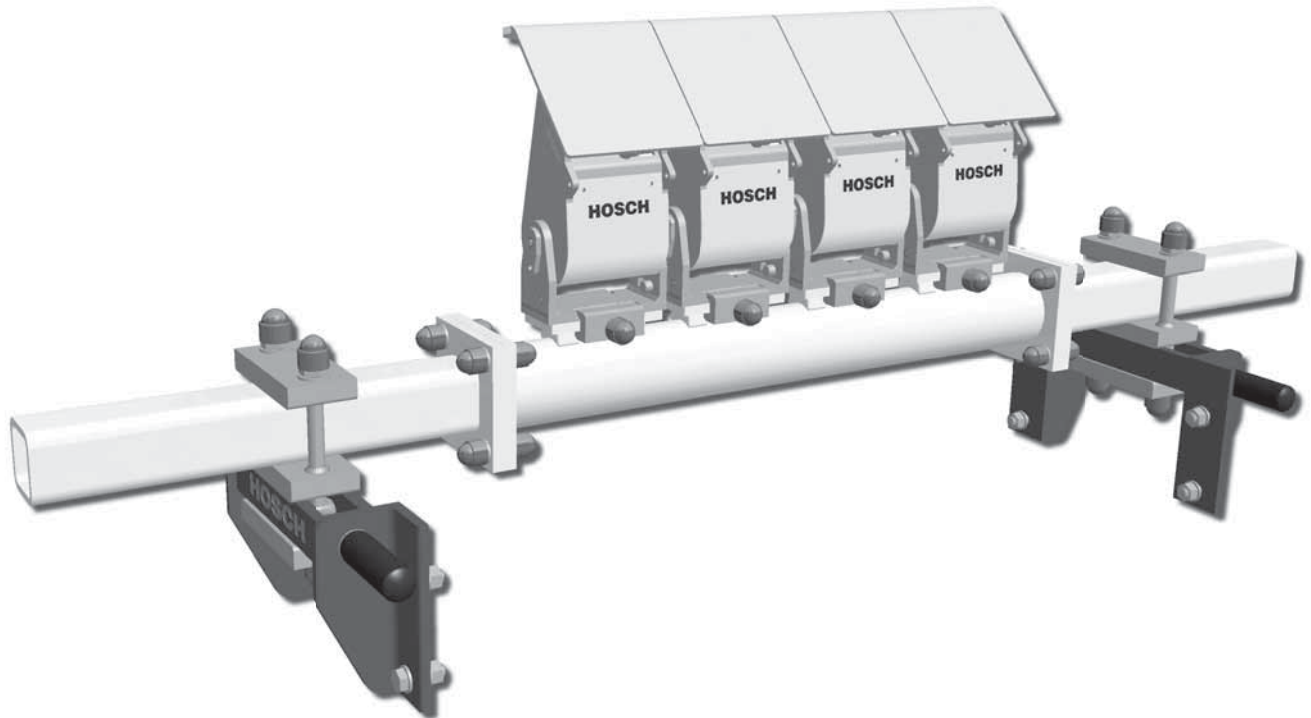

- Belt widths 1,000 up to 1,600 mm
- Belt speeds Up to 4.5 m/s
- Belt types Regular fabric or steel cord belts with a flat surface (not chevron) and with vulcanized splicing.
- Reverse operation Can operate on reversible belts
- Installation position On the front side of the head or discharge pulley at the 3 o'clock position
- Cleaning modules Sprung loaded multiple cleaning modules, with individual deflection and wear-tracking function. Only the tungsten carbide tipped cleaning elements need replacing once worn
- Design Modular scraper design, individual set-up possible to suit most applications.
- Directions for use For further technical information, please refer to additional documentation. Installation and operation manuals, dimension sheets, optional accessories and parts lists are available. Different applications must be approved by **HOSCH**.

## HOSCH Headquarters

### HOSCH-Fördertechnik GmbH

Am Stadion 36, 45659 Recklinghausen, Germany  
Tel: +49 2361 5898-0, Fax: +49 2361 589840  
e-mail: mail@hosch.de, web: www.hosch.de

## The HOSCH Group

### HOSCH International Pty Ltd.

Perth, Australia  
e-mail: mail@hosch.com.au

### HOSCH Austria GmbH

Techelsberg am Wörther See, Austria  
e-mail: office@hosch-austria.at

### HOSCH do Brasil Ltda.

Belo Horizonte, Brazil  
e-mail: hosch@hosch.com.br

### HOSCH France S.A.R.L.

Réau, France  
e-mail: info@hosch.fr

### HOSCH (G.B.) Ltd.

Thornaby, Great Britain  
e-mail: mail@hosch.co.uk

### HOSCH Hellas Monoprosopi E.P.E.

Thessaloniki, Greece  
e-mail: hosch@otenet.gr

### HOSCH Equipment (India) PVT Ltd.

Calcutta, India  
e-mail: hosch@cal.vsnl.net.in

### HOSCH Italia S.R.L.

Pontecagnano, Italy  
e-mail: mail@hosch.it

### HOSCH Techniki Transportowe Polska Sp. z o.o.

Wrocław, Poland  
e-mail: hosch@hosch.pl

### HOSCH Fördertechnik (SA) (Pty) Ltd.

Johannesburg, South Africa  
e-mail: sales@hoschsa.co.za

### HOSCH Iberia S.R.L.U.

Barcelona, Spain  
e-mail: hosch@hosch.es

### HOSCH Schweiz GmbH

Rotkreuz, Switzerland  
e-mail: mail@hosch.de

### HOSCH COMPANY

Pittsburgh, USA  
e-mail: hosch@hoschusa.com



©2010 HOSCH-Fördertechnik GmbH

No part of this publication may be reproduced, transmitted, transcribed, stored in any retrieval system or translated into any human or computer language by any means or in any form, without the prior written permission of HOSCH-Fördertechnik GmbH. Contravention of the owner's copyright may also reduce the ability of HOSCH-Fördertechnik GmbH to provide effective support for its equipment.

HOSCH-Fördertechnik GmbH reserves the right to make changes without notice to both this document and to its products described within this document. Nothing in this publication represents any contractual or other commitment on the part of HOSCH-Fördertechnik GmbH and should not be taken as such. All possible care has been taken in the preparation of this publication.

However, if you find any errors or would like to make suggestions for improvement then write to HOSCH-Fördertechnik GmbH.