

**HOSCH  
SPRUNG  
BLADE  
SCRAPERS**

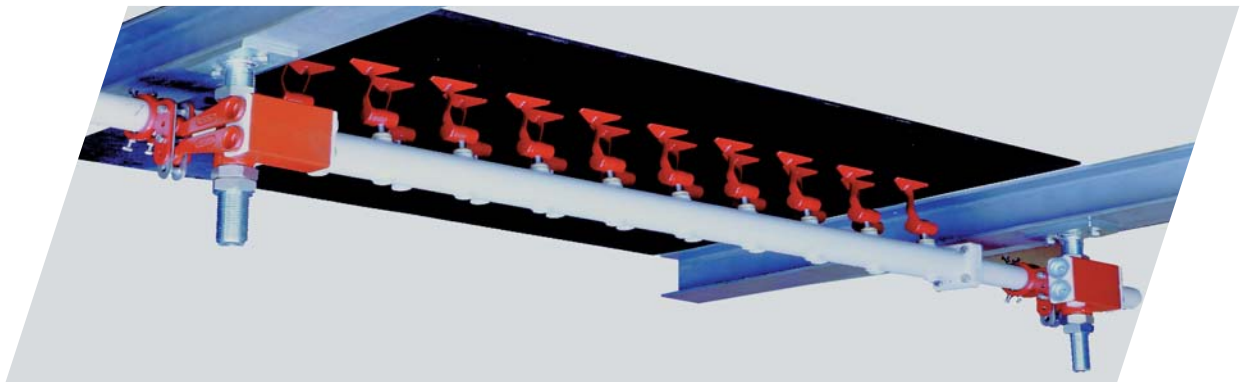

TYPE **C3**

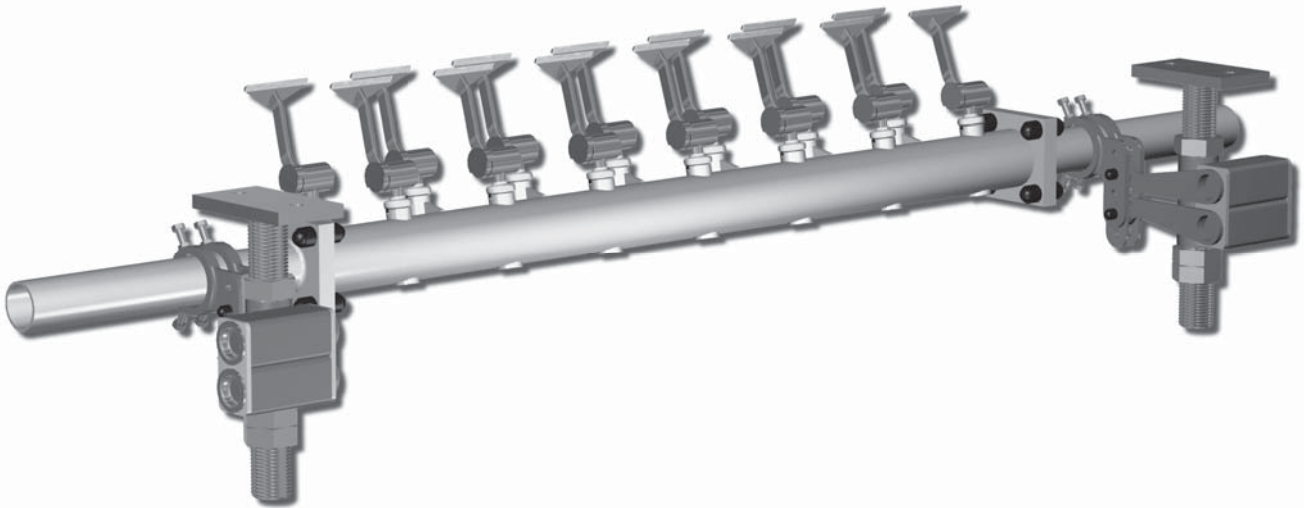

**Type C3**  
**The new dimension**  
**for larger conveyor belts -**  
**Extending the advanced**  
**technology**

Belt width	Cleaning width	Modules	Assembly carrier length	Assembly carrier midsection length	Parallel elasto-mount	Spindle
mm	mm	Qty.	mm	mm	Type	Type
1600	1485	14	3005	1575	E	M60
1800	1695	16	3215	1785		
2000	1905	18	3425	1995		
2200	2010	19	3530	2100		
2400	2220	21	3740	2310		
2600	2430	23	3950	2520	F	
2800	2640	25	4160	2730		
3000	2850	27	4370	2940		
3200	3060	29	4580	3150		

- The HOSCH Sprung Blade Scraper, Type C3, with self-adjustment aligns itself automatically according to the belt thickness / profile.
- The matching components of the construction kit can be assembled as required.
- The scraper system offers easy assembly on site and flexibility to suit any conveyor frame.
- The modules offer maintenance-free self-adjustment and push-in fastening.
- Type C3 means greatly improved HOSCH precision cleaning with a compact unit and more user-friendly.

**HOSCH Sprung Blade Scraper**  
**Reliable state of the art**

- Unsurpassed cleaning efficiency
- Installed in all industrial sectors
- Low operating costs

**HOSCH Fördertechnik GmbH**

Am Stadion 36  
 D-45659 Recklinghausen (Germany)  
 Tel. : +49 (0) 2361 / 58 98 - 0  
 Fax : +49 (0) 2361 / 58 98 40  
 eMail : mail@hosch.de

Sales Office