

**HOSCH  
SPRUNG  
BLADE  
SCRAPERS**

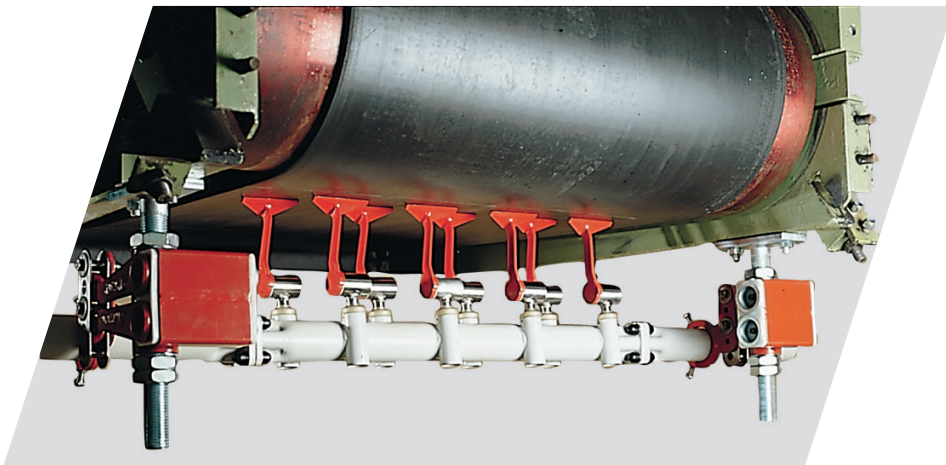

TYPE **C2**

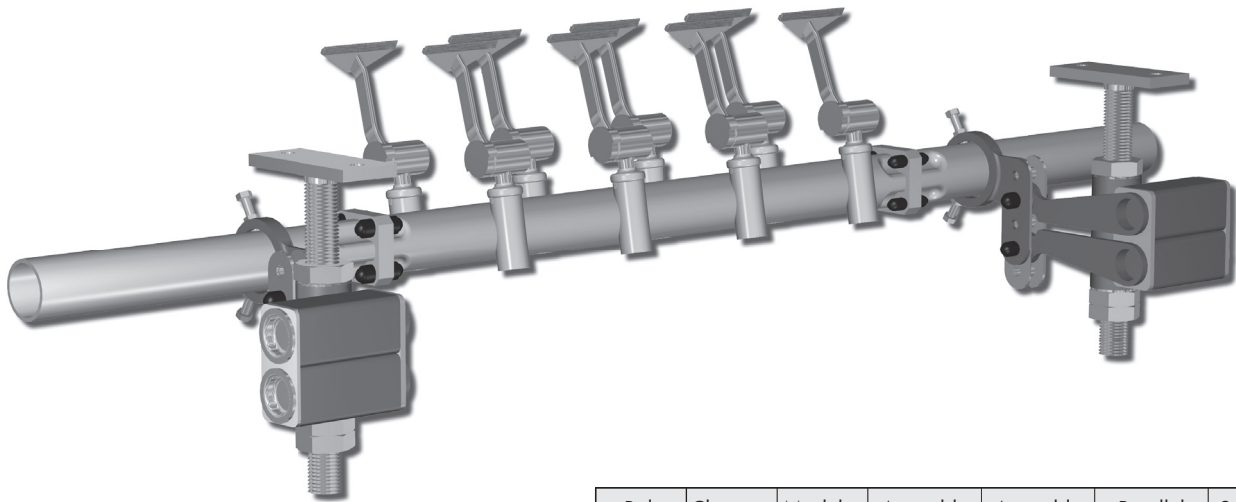

Belt width	Cleaning width	Modules	Assembly carrier length	Assembly carrier midsection length	Parallel elastomount	Spindle
mm	mm	Qty.	mm	mm	Type	Type
600	540	5	1640	620	B	M42
650	540	5				
700	645	6	1850	830		
750	645	6				
800	750	7				
900	750	7	1955	935		
1000	855	8				
1050	960	9				
1200	1065	10				
1300	1170	11	2375	1355	C	
1350	1275	12				
1400	1275	12				
1500	1380	13	2585	1565	D	M60
1600	1485	14	2985	1565		
1800	1695	16	3195	1775		
2000	1905	18	3405	1985		

## Type C2 THE NEW INNOVATION An Advanced Technology

- The **HOSCH Sprung Blade Scraper, Type C2**, with self-adjustment aligns itself automatically according to the belt thickness / profile.
- The matching components of the construction kit can be assembled as required.
- The scraper system offers easy assembly on site and flexibility to suit conveyor frame structures.
- The modules offer maintenance-free self-adjustment and push-in fastening to minimise maintenance.
- **Type C2** means greatly improved **HOSCH** precision cleaning with a compact unit and more user-friendly.

## HOSCH Sprung Blade Scraper Reliable state of the art

- Unsurpassed cleaning efficiency
- Installed in all industrial sectors
- Low operating costs

### HOSCH Fördertechnik GmbH

Am Stadion 36  
D-45659 Recklinghausen (Germany)  
Tel. : +49 (0) 2361 / 58 98 - 0  
Fax : +49 (0) 2361 / 58 98 40  
eMail : mail@hosch.de

Sales Office