

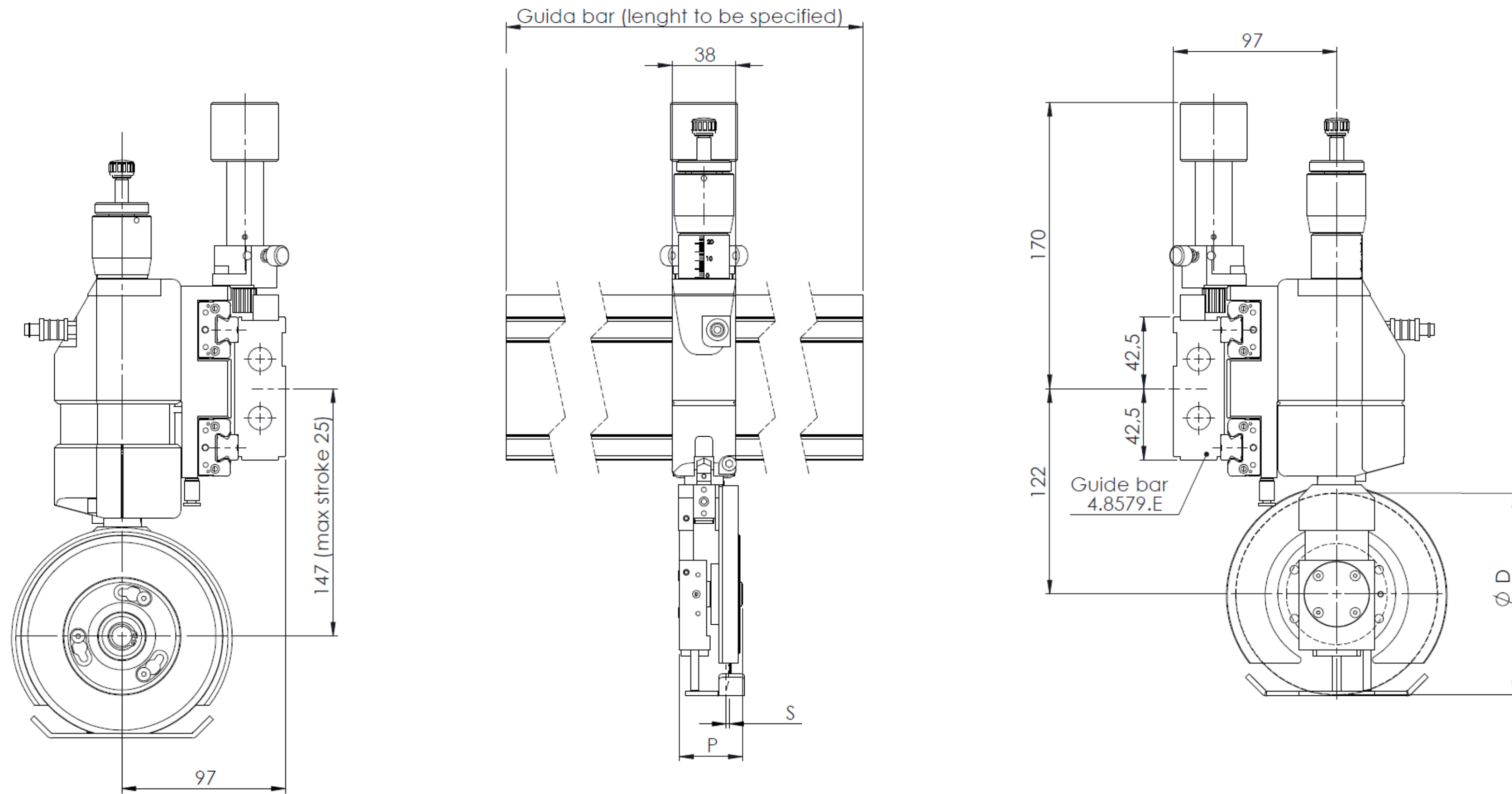

# J2-40C pneumatic knifeholders

For paper, film, plastic, textile, laminates, fibreglass, nonwoven, rubber, aluminum, etc....

Paper	Up to 400gr/m <sup>2</sup>
Plastic, Film	from 25μ to 500μ
Nonwoven	Up to 500gr/m <sup>2</sup>
Max speed	1000m/min
Min. slit	40mm
Blade stroke, max	25mm



**Indicative values, for alternative material  
s ask for our evaluation**

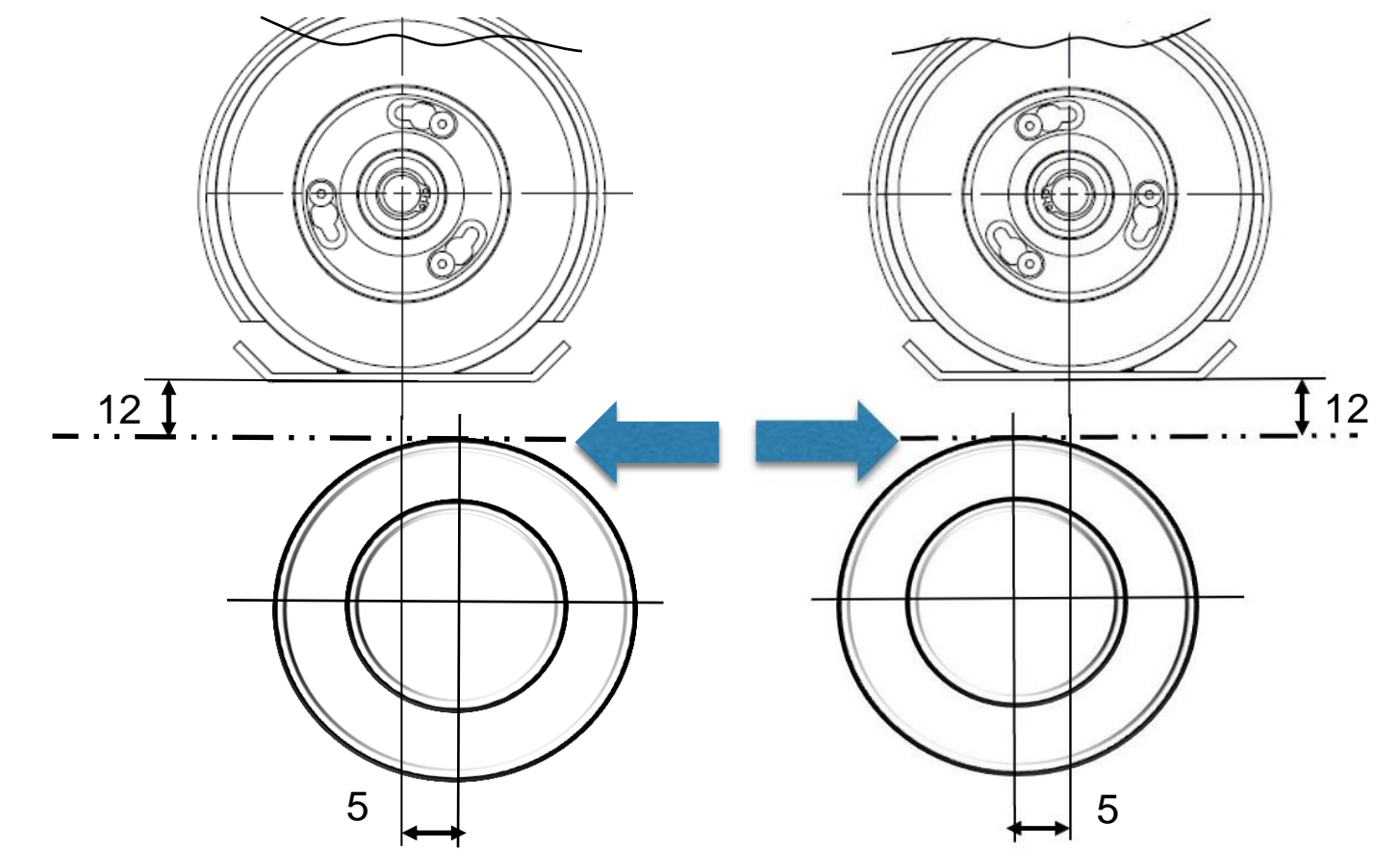

Knifeholder type	Ø D	P	S
J2 40C	90÷105÷120	40	2

*For any information specific to your application please contact us*



**J2-40C**  
**pneumatic knifeholders**

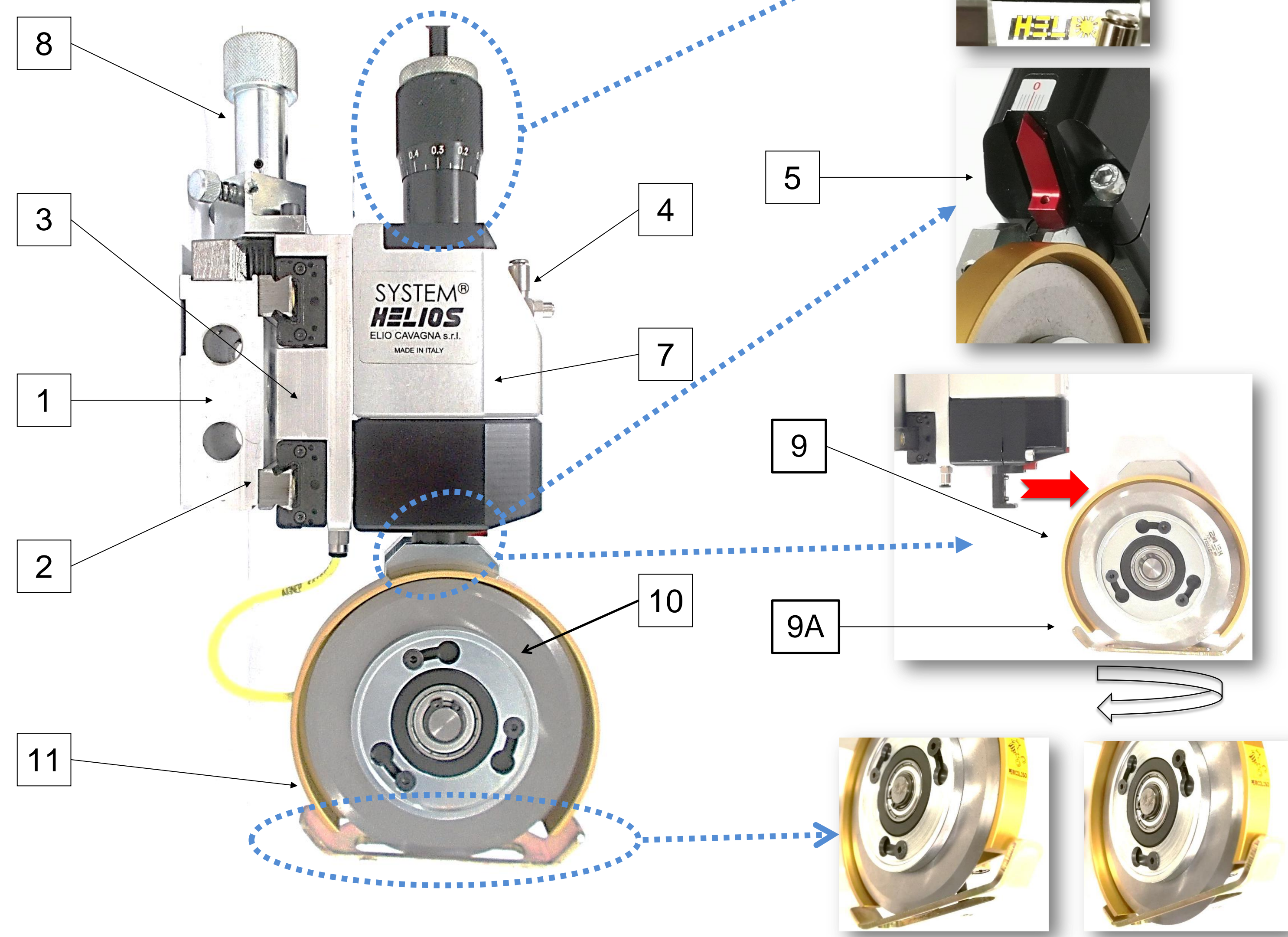

**MAIN FEATURES**

1. Double rail guide
2. Double linear bearing
3. Pneumatic brake
4. Blade descent and side stroke with single alimentation
5. Blade cutting angle adjusting from 0 to 2°
6. Blade depth regulation, with nonius
7. Body with double piston for blade descent
8. Knob with pinion for movement
9. Frontal head extraction
  - 9 A. 180° head rotation
10. Bayonet blade assembling
11. 360° automatic blade protection



## J2-40C pneumatic knifeholders

### OPTIONAL LIST

LASER TO CHECK BLADE POSITION

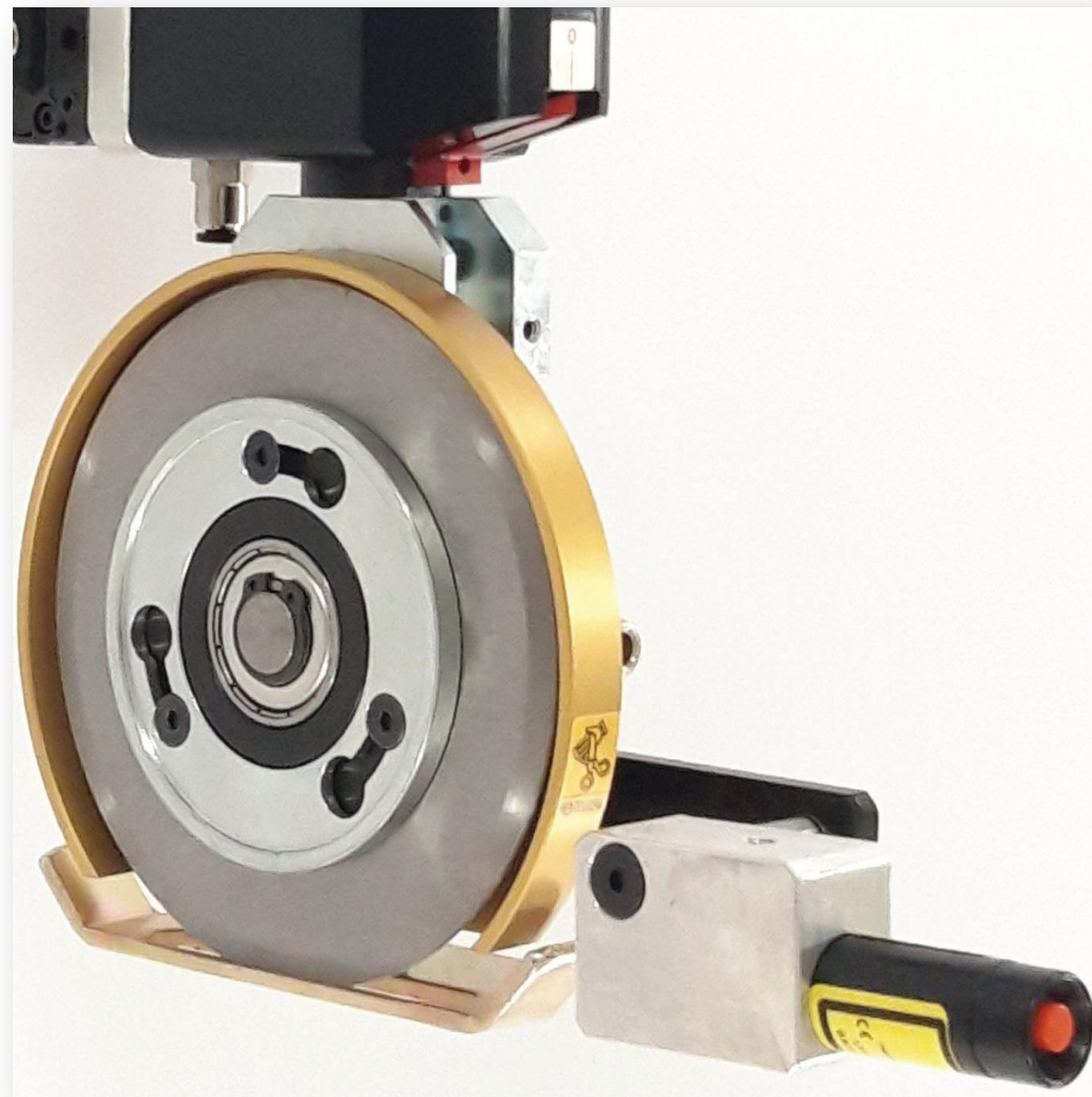

PLEXIGLASS SIDE COVER FOR BLADE

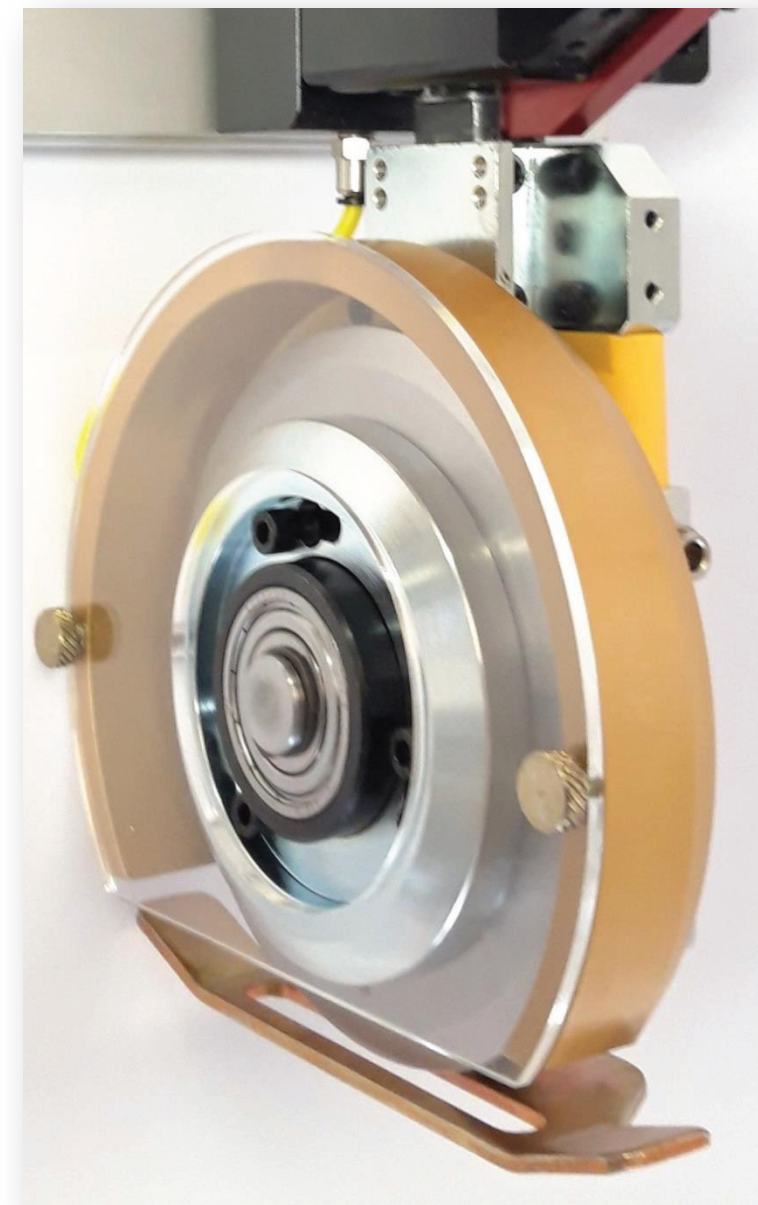

COVER FOR DUST EXTRACTION



FELT FOR BLADE LUBRICATION



INTERCHANGEABILITY WITH RAZOR BLADE

