



# RV1D

## VARIABLE DISPLACEMENT VANE PUMPS WITH DIRECT PRESSURE ADJUSTER

SERIES 10

### OPERATING PRINCIPLE

- The RV1D pumps are variable displacement vane pumps with mechanical pressure compensator.
- The pressure compensator keeps the cam ring of the pumping group in the eccentric position with use of an adjustable load spring. When the delivery pressure equals the pressure corresponding to the spring setting, the cam ring is moved toward the center instantaneously, adjusting the flow rate to the values required by the plant.
- Energy consumption is reduced and adequate in every phase of the cycle.
- The pump group has hydrostatic axial compensation distribution plates, that improve the volumetric efficiency and reduce wear of the components.
- In zero flow demand conditions, the pump delivers fluid only to compensate any possible leaks and pilot lines, keeping constant the circuit pressure .
- The compensator response times are very low such as to make unnecessary the pressure relief valve.

### PERFORMANCE RATINGS (measured with mineral oil with viscosity of 46 cSt at 40°C)

		016	020	025	032	040	050	063	080	100	120
Geometric displacement	cm <sup>3</sup> /rev	16	20	25	32	40	50	63	80	100	120
Actual displacement (±3%)	cm <sup>3</sup> /rev	17	21	26	33	42	51	63	80	100	123
Maximum flow at 1500 rpm	l/min	25,5	31,5	39	49,5	63	76,5	94,5	120	150	184,5
Max working pressure	bar	120	100		100			90			
Pressure adjustment range	bar	20 ÷ 120	30 ÷ 100		30 ÷ 100			50 ÷ 90			
Maximum drain port pressure allowed	bar	1									
Rotation speed range	rpm	800 ÷ 1800				800 ÷ 1500					
Rotation direction		clockwise (seen from the shaft side)									
Shaft loads		radial and axial loads are not allowed									
Max applicable torque on shaft: type R55 type R97	Nm	110 70	250 -		586 -			900 -			
Mass	kg	7,4	18,3		43,8			56			

Ambient temperature range	°C	-20 / +50
Fluid temperature range	°C	+15 / +60
Recommended viscosity	cSt	22 ÷ 68
Fluid viscosity range		see paragraph 2.2
Degree of fluid contamination		see paragraph 2.3

### HYDRAULIC SYMBOL

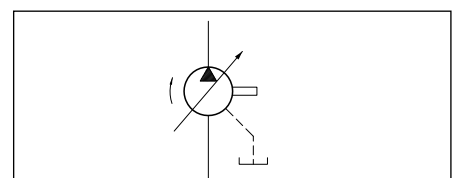



## 1 - IDENTIFICATION CODE

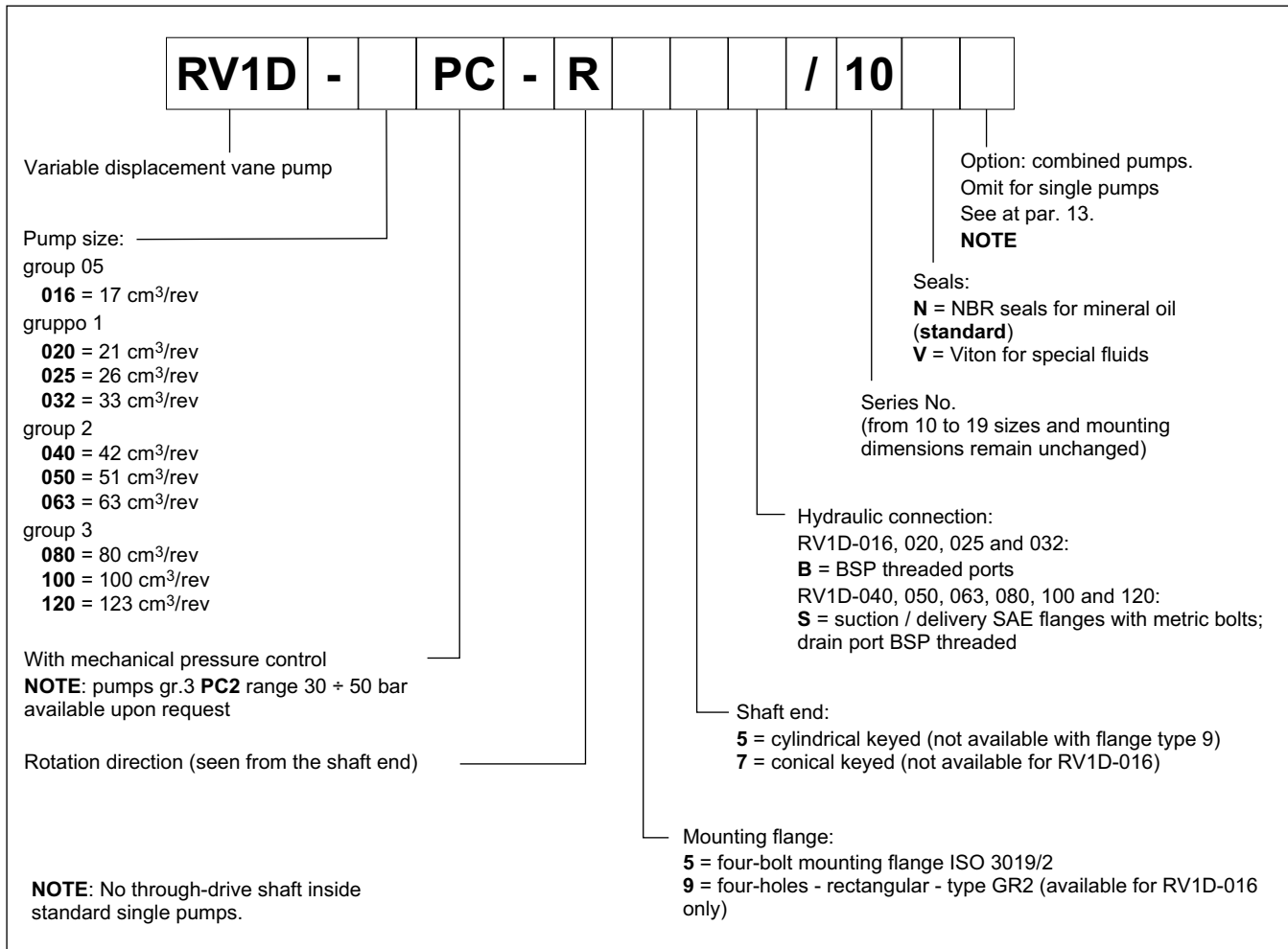

## 2 - HYDRAULIC FLUID

### 2.1 - Fluid type

Use mineral oil based hydraulic fluids with anti-foam and antioxidant additives. For use of other types of fluid, keep in mind the limitations shown in the following table or consult our technical department for approval.

FLUID TYPE	NOTES
HFC (water glycol solutions with proportion of water ≤ 40%)	-The values shown in the performance ratings table must be reduced by at least 50% - The pump rotation speed must be limited to 1000 rpm. - Use NBR seals only
HFD (phosphate esters)	There are no particular limitations with this kinds of fluids. Operation with a fluid viscosity as close as possible to the optimum viscosity range specified in par. 2.2 is recommended. - Use FPM (Viton) seals only

### 2.2 - Fluid viscosity

The operating fluid viscosity must be within the following range:

optimum viscosity	22 ÷ 68 cSt	referred to the fluid working temperature in the tank
maximum viscosity	400 cSt	limited to only the start-up phase of the pump

When selecting the fluid type, be sure that the true viscosity is within the range specified above at the operating temperature.

### 2.3 - Degree of fluid contamination

The maximum degree of fluid contamination must be according to ISO 4406:1999 class 20/18/15; therefore, use of a filter with  $\beta_{20} \geq 75$  is recommended. A degree of maximum fluid contamination according to ISO 4406:1999 class 18/16/13 is recommended for optimum endurance of the pump. Hence, use of a filter with  $\beta_{10} \geq 100$  is recommended.

The suction filter must be equipped with a by-pass valve and, if possible, with a clogging indicator. See installation section for details.

### 3 - CHARACTERISTIC CURVES RV1D-016 (GR. 05)

(obtained with viscosity of 46 cSt at 40°C)

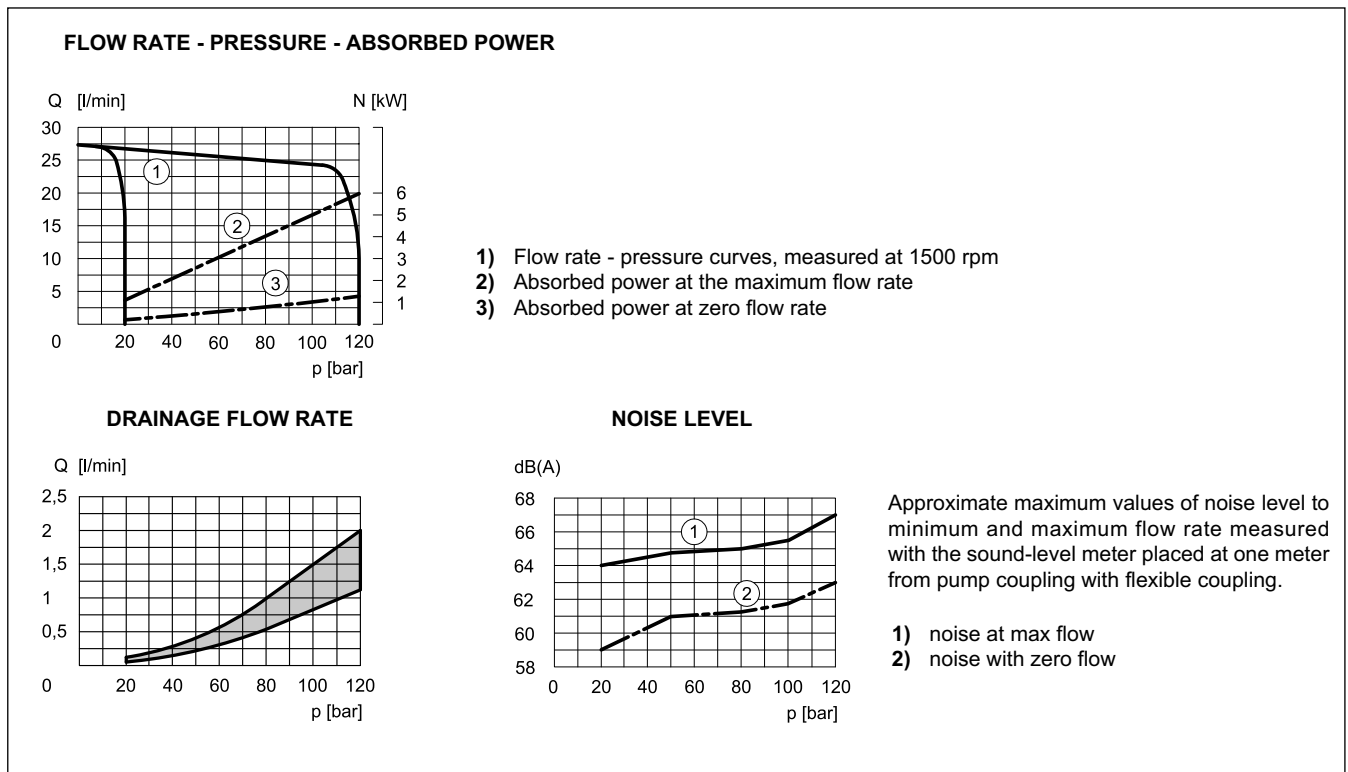

### 4 - CHARACTERISTIC CURVES OF RV1D-020, RV1D-025 AND RV1D-032 (GR. 1)

(obtained with viscosity of 46 cSt at 40°C)

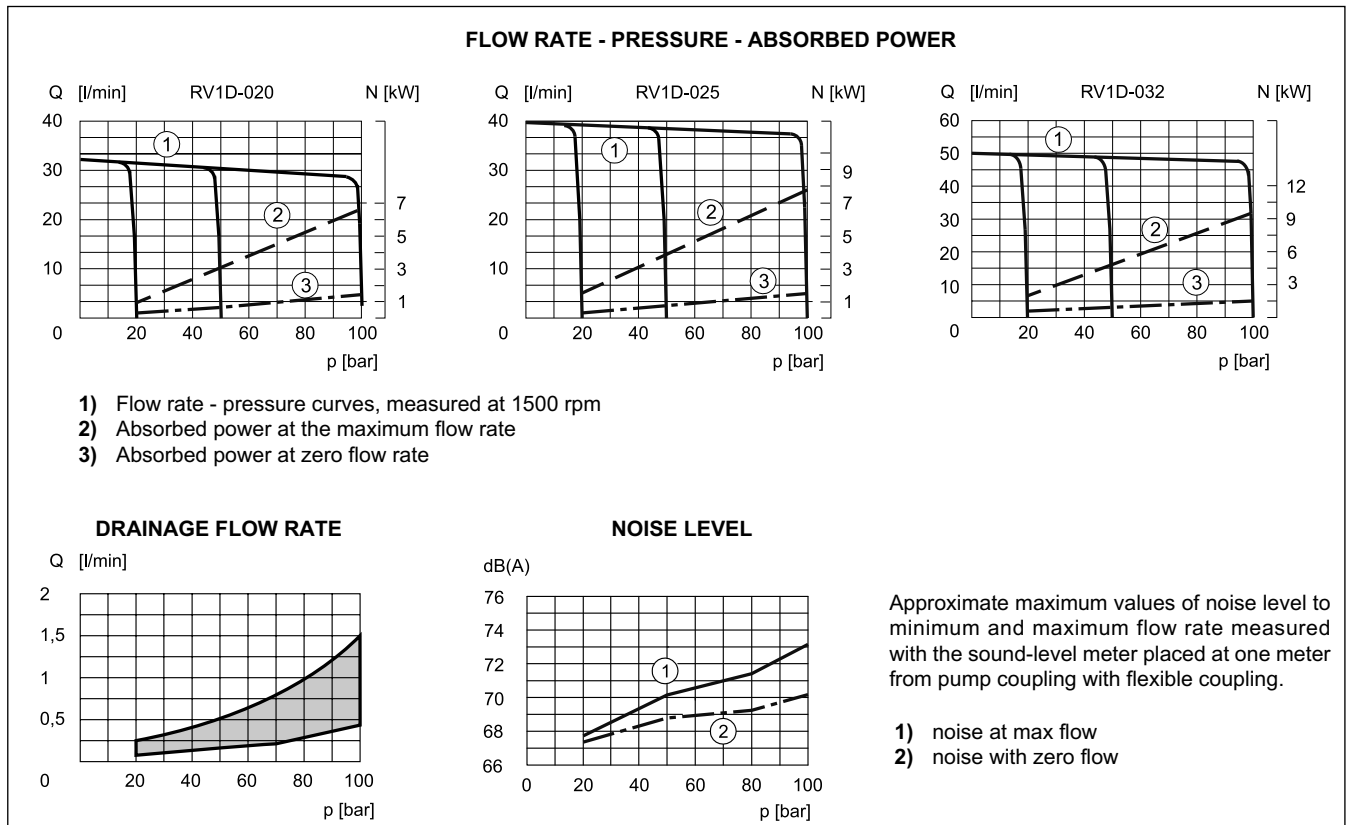

### 5 - CHARACTERISTIC CURVES FOR RV1D-040, RV1D-050 AND RV1D-063 (GR. 2)

(values obtained with mineral oil with viscosity of 46 cSt at 40°C)

#### FLOW RATE - PRESSURE - ABSORBED POWER

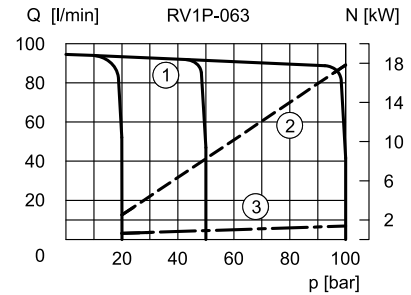
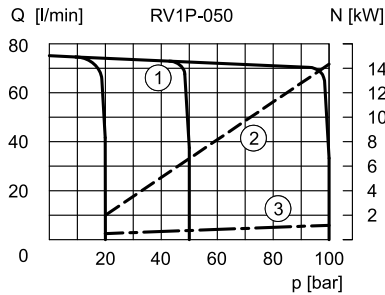
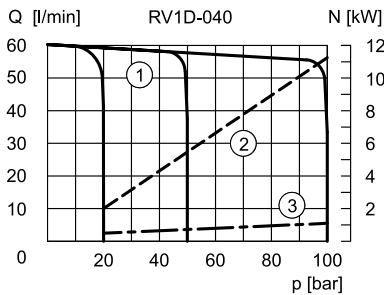

- 1) Flow rate - pressure curves, measured at 1500 rpm
- 2) Absorbed power at the maximum flow rate
- 3) Absorbed power at zero flow rate

#### DRAINAGE FLOW RATE

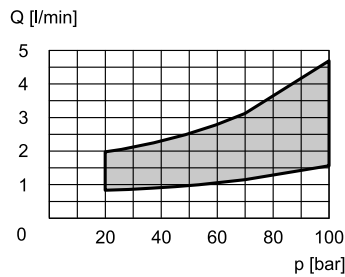

#### NOISE LEVEL

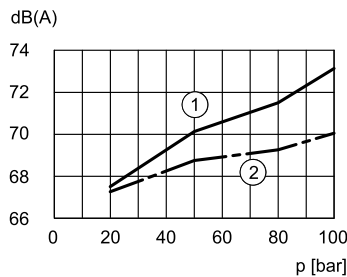

Approximate maximum values of noise level to minimum and maximum flow rate measured with the sound-level meter placed at one meter from pump coupling with flexible coupling.

- 1) noise at max flow
- 2) noise with zero flow

### 6 - CHARACTERISTIC CURVES FOR RV1D-080, RV1D-100 E RV1D-120 (GR. 3)

(values obtained with mineral oil viscosity of 46 cSt at 40°C)

#### FLOW RATE - PRESSURE - ABSORBED POWER

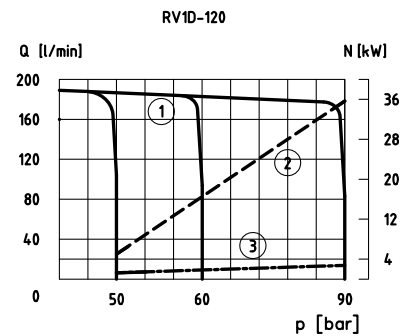
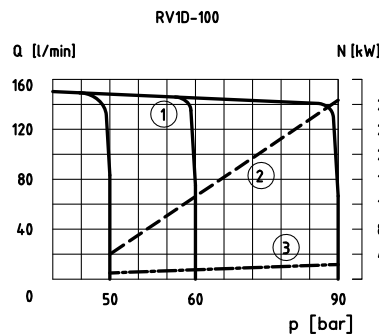
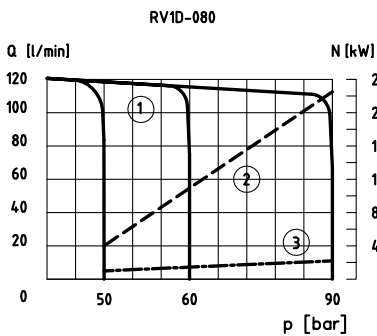

- 1) Flow rate - pressure curves, measured at 1500 rpm
- 2) Absorbed power at the maximum flow rate
- 3) Absorbed power at zero flow rate

#### DRAINAGE FLOW RATE

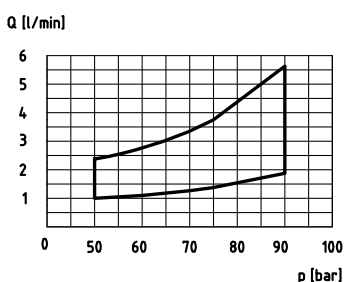

#### NOISE LEVEL

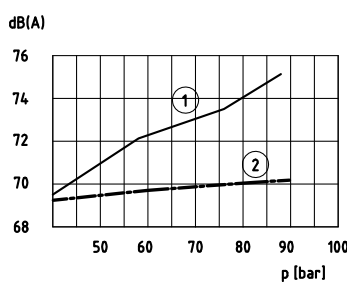

Approximate maximum values of noise level to minimum and maximum flow rate measured with the sound-level meter placed at one meter from pump coupling with flexible coupling.

- 1) noise at max flow
- 2) noise with zero flow

7 - OVERALL AND MOUNTING DIMENSIONS RV1D-016 (GR. 05)

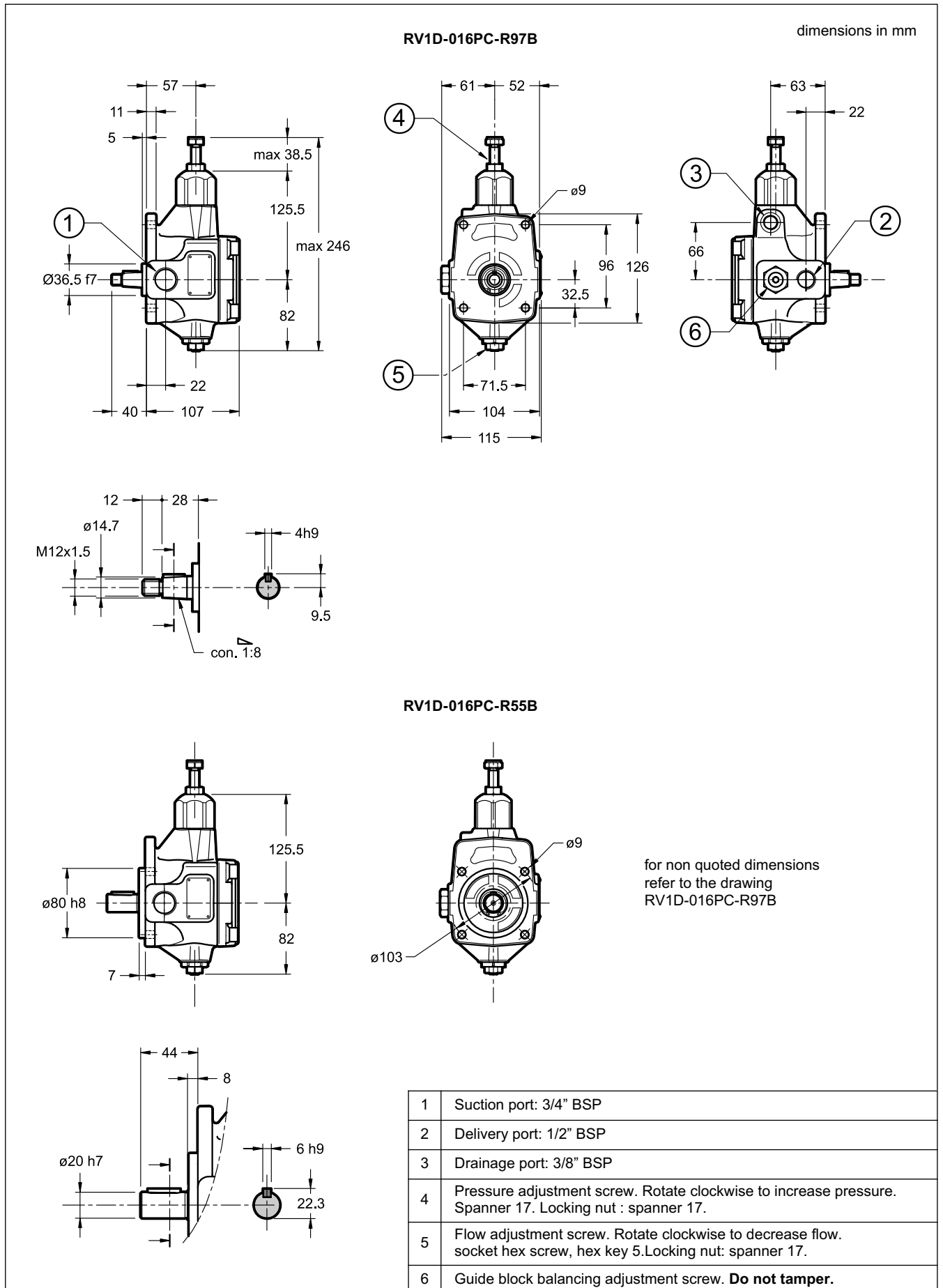

## 8 - OVERALL AND MOUNTING DIMENSIONS RV1D-020, RV1D-025 AND RV1D-032 (GR.1)

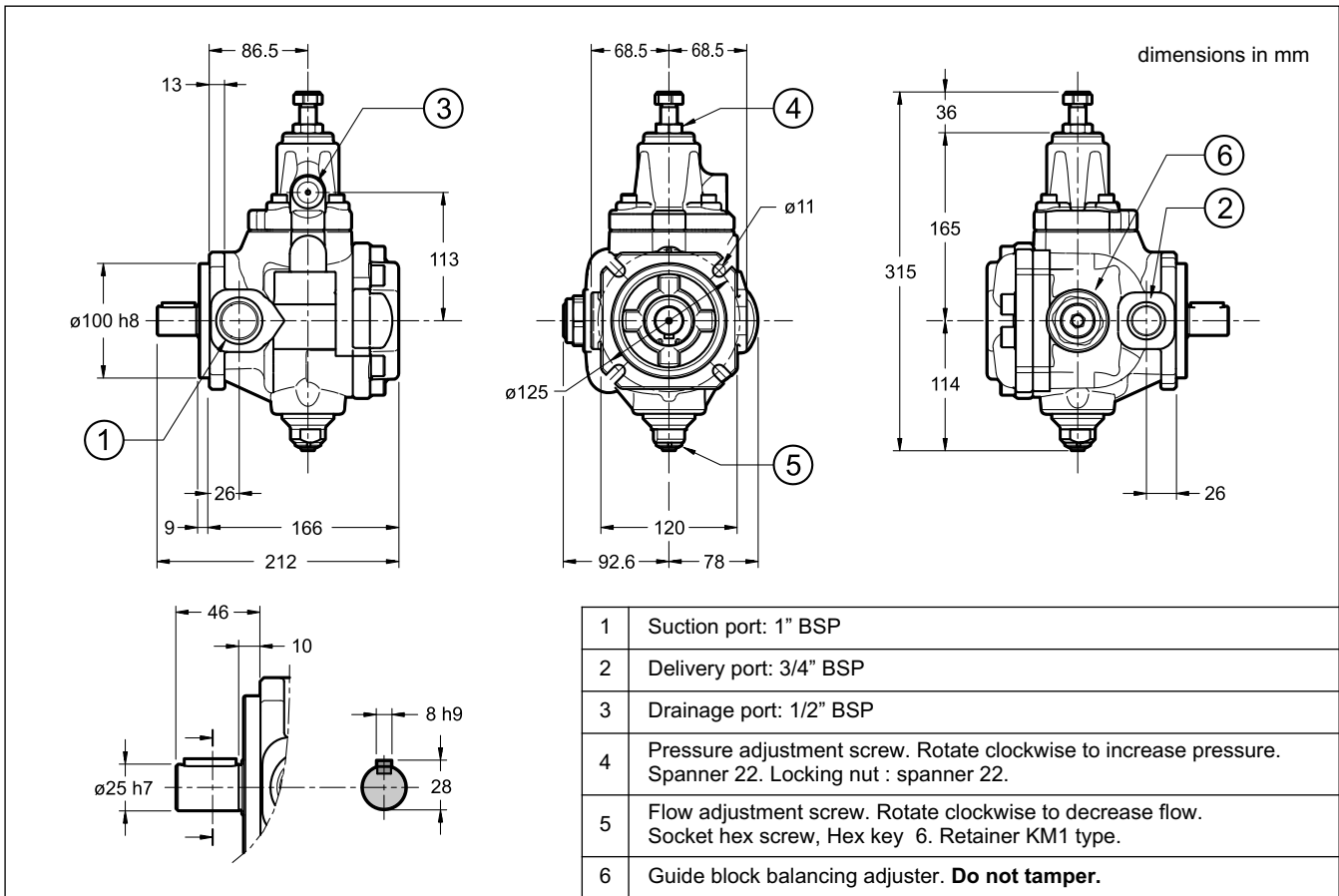

## 10 - OVERALL AND MOUNTING DIMENSIONS RV1D-040, RV1D-050 AND RV1D-063 (GR.2)

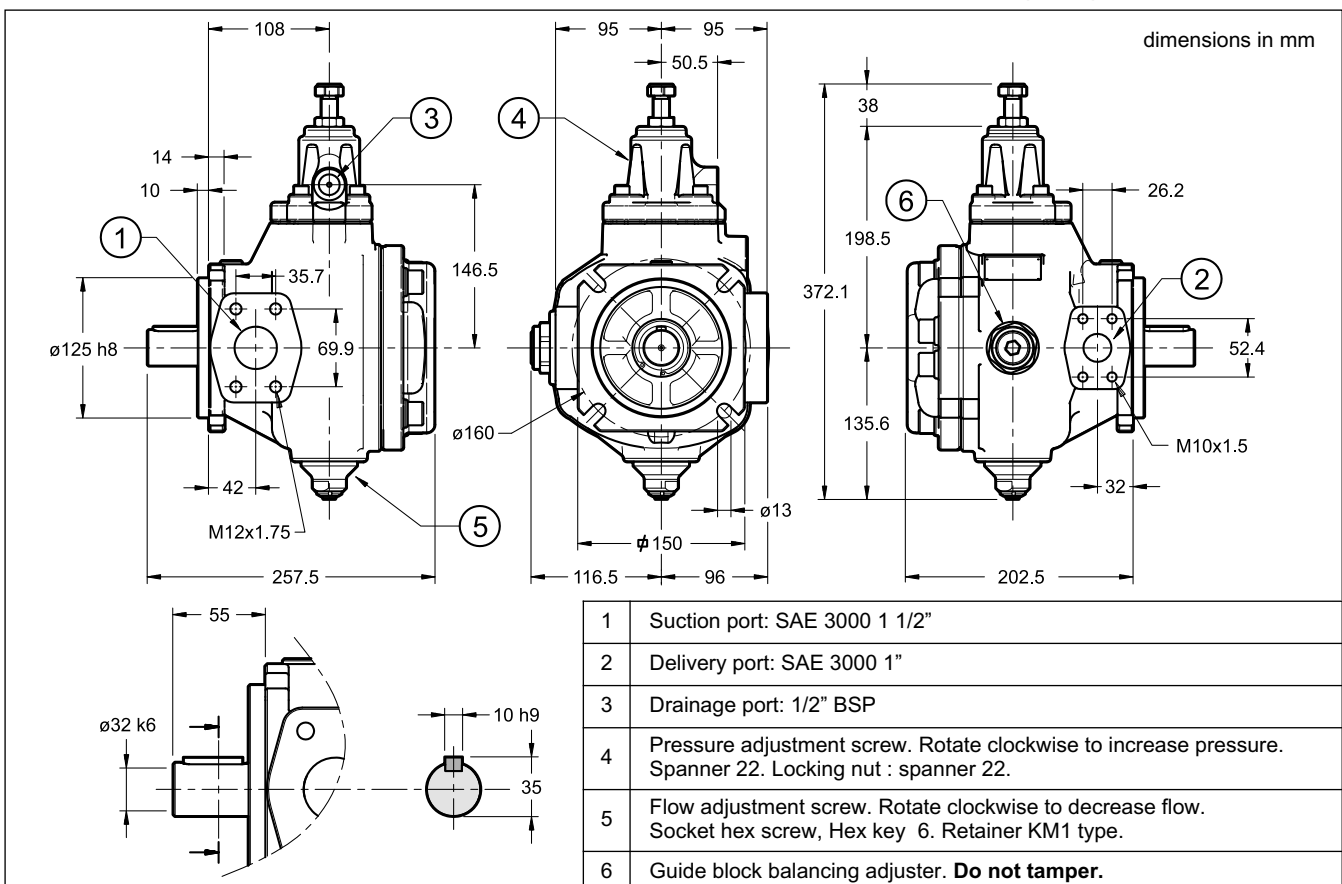

## 9 - OVERALL AND MOUNTING DIMENSIONS RV1D-080, RV1D-100, RV1D-120 (GR. 3)

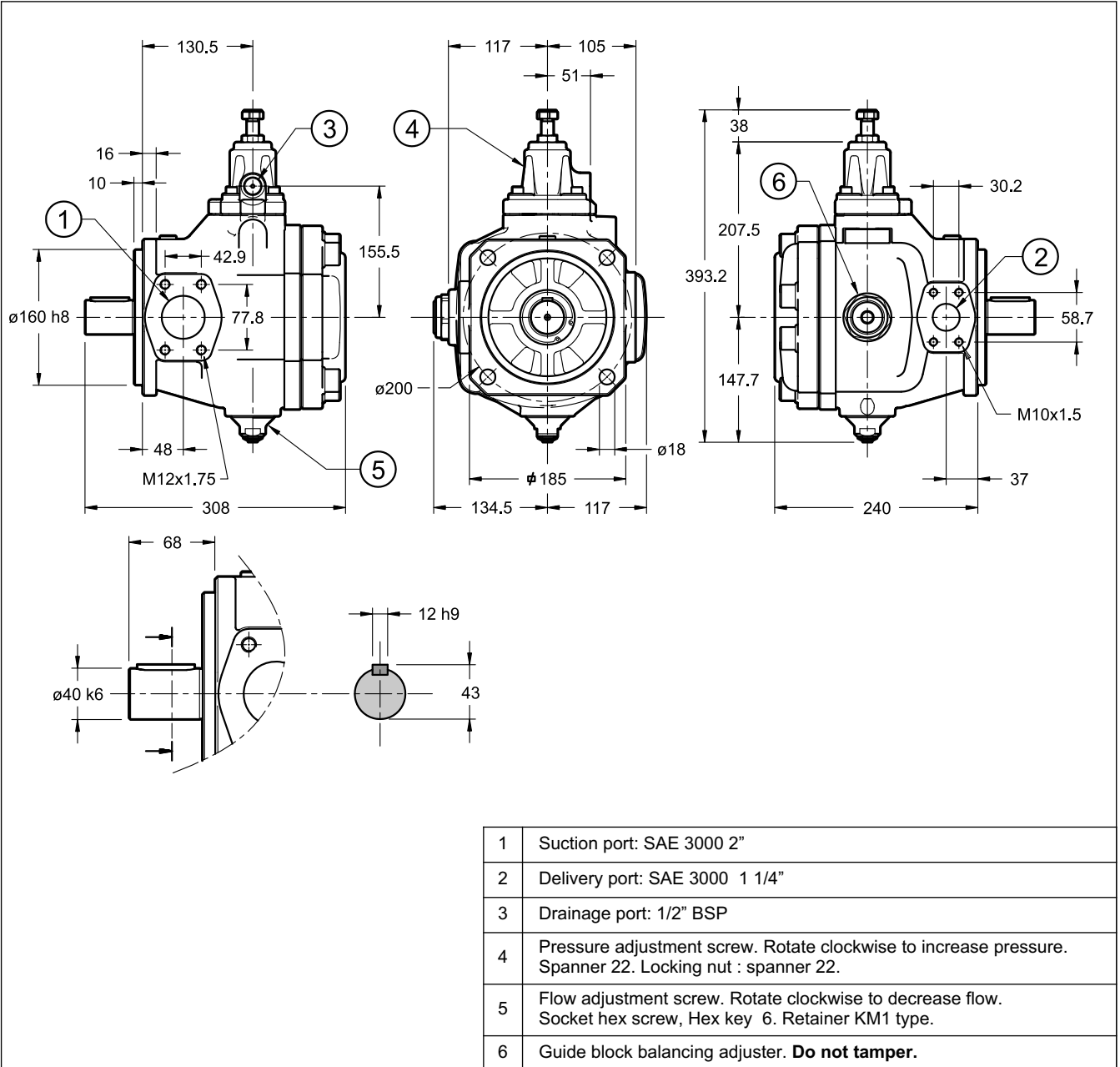



## 11 - INSTALLATION

The instruction manual for pumps installation and commissioning is always included in the packaging with the pump. Observe restrictions in this document and follow the instructions.

- RV1D-016, RV1D-020, RV1D-025 and RV1D-032 pumps can be installed in any position.

All the other pumps need to be installed with the axis in horizontal position and with pressure compensator upward.

- Motor-pump coupling must be made with a self-aligning flexible coupling with convex teeth and a polyamide cam. Couplings that generate axial or radial loads on the pump shaft are not allowed.
- The suction line must be short, with a small number of bends and without internal section changes. The minimum section of the inlet pipe must be equal to the section of the thread of the pump inlet port.

The pipe-end inside the tank should be cut at 45°, should have a minimum distance from the tank bottom of not less than 50 mm, and there should always be a minimum height of suction of 100 mm. **The suction pipe should be completely airtight in order to avoid air intake which could be extremely damaging to the pump.**

**Suction pressure should be between 0.8 and 1.5 bar absolute**

- The drainage pipe must be connected directly to the tank by a line separate from other discharges, located as far as possible from the suction line and lengthened to below the minimum oil level in order to avoid foaming.
- The fluid tank must be suitably sized in order to exchange the thermal power generated by the various system components and to provide a low recycle rate (approximately: tank capacity = 4 times the pump flow rate per minute).  
In systems where the pump runs for a long time under zero-flow

setting conditions, it is advisable to provide a fluid cooling system.

**The pressure in the drain line must not exceed 1 bar.**

To ensure the maximum pump working life, the inlet fluid temperature must never be above 50°C. **The fluid temperature must never exceed 60 °C**

- **Ensure the pump shaft can be rotated manually without any resistance.**
- The pump must be started-up in full displacement (P→T) with flow to the tank without pressure for several minutes, to purge the air.  
The pump should prime within 5 seconds. If it does not, switch it off and investigate the cause. The pump should not run empty.
- If the volume adjuster has been set for values less than 50% of the nominal flow-rate, start-up is allowed only if provided the system and the pump are completely filled with fluid.
- **It's essential that the difference between the fluid temperature and the ambient (pump body) temperature doesn't exceed 20 °C.**  
If this is the case, the pump should be switched-on only for intervals of about 1-2 seconds (start/stop mode) without pressure, until the temperatures came balanced.
- The pumps are usually placed directly upon the fluid tank. Flooded suction port installation of the pump is recommended in the event of circuits with high flow rates and pressures.

## 12 - VOLUME ADJUSTMENT SCREW

The volume adjuster is fitted as standard on all the pumps.

It consists of an adjustment screw and a small balanced piston that limit the maximum eccentricity of the pumping group cam ring, changing the displacement. The maximum flow is reduced by turning the adjustment screw clockwise. Indicative data, sensitive to performance tolerances.

Nominal size		016	020	025	032	040	050	063	080	100	120
Reduction of displacement per turn	cm <sup>3</sup>	9,7	10			16			16		
Minimum possible displacement	cm <sup>3</sup> /rev	3,1	9,5	15	19	27,5	35,5	43,5	63	80	100

Tools required for adjustment:

RV1D-016: adjustment screw hexagon socket key 5. Locking nut spanner 17.  
Other sizes: adjustment screw hexagon socket key 6. Tooth retainer KM1 type.



## 13 - MULTIPLE PUMPS

RV1D with through drive shaft are available. These pumps are designed to be connected one to the other in decreasing order of displacement. The RV1D-016 pump suitable for multiple pumps is the R55B version only (ISO 3019-2 four-bolt flange with cylindrical keyed shaft end)

RV1D pumps can be coupled also with RV1P type pumps (see catalogue 14 201) and with GP gear pumps (see catalogue 11 100). The torque on the shaft must be further reduced after the second pump.

Consult our Sales Support department for this kind of applications.

### IDENTIFICATION CODE FOR MULTIPLE PUMPS

Both single pumps with through drive shaft (without mating joint) and multiple groups are available.

Fill the ordering code, by following the coupling sequence of the pumps. Insert the /F suffix after each pump with through drive shaft:

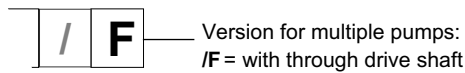

identification code + identification code + identification code  
 front pump + intermediate pump + rear pump  
 /F /F

Examples:

Single pump with through drive shaft: RV1D-016PC-R55B/10V/F

Double pump identification: RV1D-016PC-R55B/10V/F + RV1D-016PC-R55B/10V

Triple pump identification: RV1D-025PC-R55B/10N/F + RV1D-025PC-R55B/10N/F + RV1D-025PC-R55B/10N

RV1D pump + gear pump identification: RV1D-050PC-R55B/10N/F + GP2-00208R97F/20N

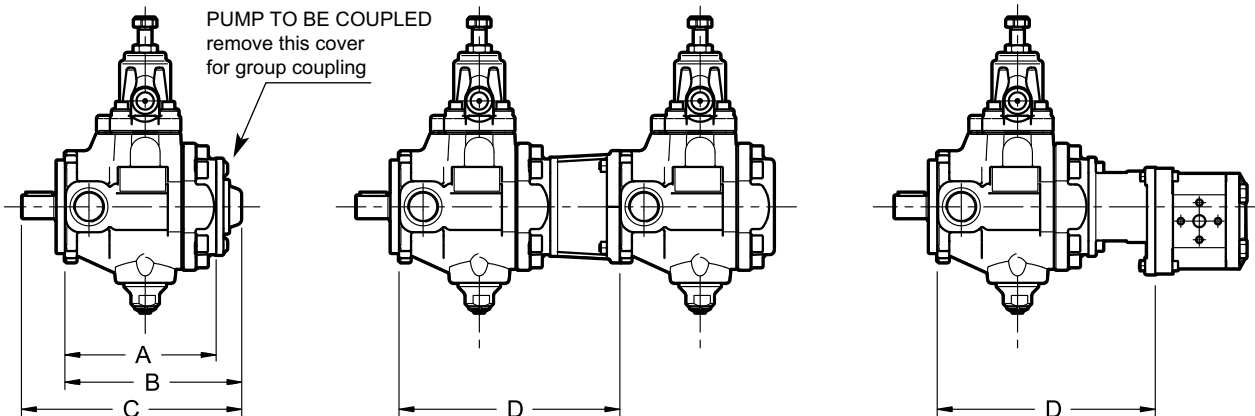

Dimensions (mm)

Group size	A	B	C	D with RV1D pump of same size group.	D with gear pump type GP1 / GP2 / GP3
05	104	131	175	177	168 / 176 / -
1	163	190	236	238	227 / 235 / -
2	199,5	246,5	301,5	301,5	289,5 / 289,5 / 290,5
3	237	284	352	354	327 / 327 / 328

Max torque applied to the shaft of the second pump (Nm)

Group size Front pump	Second pump (same size group)	Second pump (smaller size group)
05	55	-
1	55	55
2	110	110
3	180	110

14 - CONNECTION FLANGES

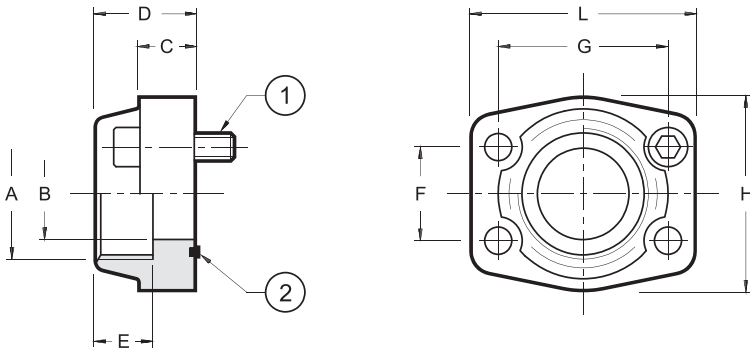

the fastening bolts and the O-Rings must be ordered separately

flange code	flange description	$P_{max}$ [bar]	$\varnothing A$	$\varnothing B$	C	D	E	F	G	H	L	(1) n° 4 bolts	(2)
0610713	SAE - 1"	345	1" BSP	25	18	38	22	26.2	52.4	22	70	SHC M10x35	OR 4131 (32.93x3.53)
0610720	SAE - 1 1/4"	276	1 1/4" BSP	32	21	41	22	30.2	58.7	68	79	SHC M10x35	OR 4150 (37.69x3.53)
0610714	SAE - 1 1/2"	207	1 1/2" BSP	38	25	44	24	35.7	70	78	93	SHC M12x45	OR 4187 (47.22x3.53)
0610721	SAE - 2"	207	2" BSP	51	25	45	30	43	77.8	90	102	SHC M12x40	OR 4225 (56.74x3.53)

**BIBUS**<sup>®</sup>  
SUPPORTING YOUR SUCCESS

BIBUS SK, s.r.o  
Trnavská 31, SK-94 901 Nitra

Tel.: 037/ 7777 911    Email: sale@bibus.sk  
Fax.: 037/ 7777 999    http://www.bibus.sk

**DIPLOMATIC**  
MOTION SOLUTIONS

**DIPLOMATIC MS S.p.A.**

via M. Re Depaolini 24 • 20015 PARABIAGO (MI) • ITALY  
tel. +39 0331.895.111 • www.diplomatic.com • e-mail: sales.exp@diplomatic.com