



PLK08

DIRECT OPERATED PRESSURE RELIEF VALVE SERIES 10

CARTRIDGE TYPE
seat 3/4-16 UNF-2B (SAE 08)

p max **400** bar
Q max **3** l/min

SEAT DIMENSIONS: 3/4 - 16 UNF-2B (SAE 08)

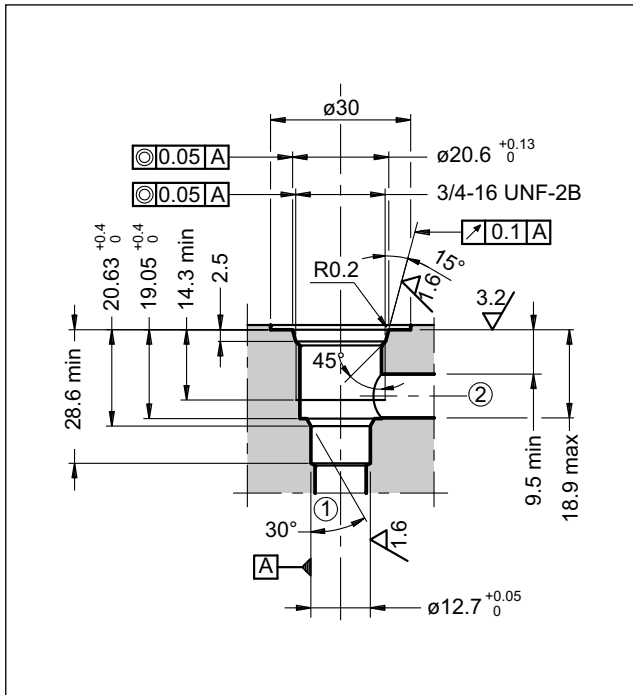

OPERATING PRINCIPLE

- The PLK08 valve is a directly controlled pressure-relief valve, cartridge type, that can be used in blocks or panels with 3/4-16 UNF-2B (SAE 08) type seat.
- It controls the maximum pressure in the hydraulic circuits or acts as a limiting device for pressure peaks generated during hydraulic actuator movement variation.
- The circuit pressure acts on the shutter which is directly loaded by a spring on the opposite side. Once the set pressure is reached, the shutter opens, and discharges the excess flow in port 2 connected directly to the reservoir.
- Six pressure control ranges are available, from 35 bar to 350 bar.
- The pressure is adjustable by a socket set screw with locking nut, or by knob.

PERFORMANCES

(measured with mineral oil of viscosity 36 cSt at 50 °C)

| | | |
|---|---|-----------|
| Max working pressure | bar | 400 |
| Minimum controlled pressure | see diagrams | |
| Maximum flow rate | l/min | 3 |
| Ambient temperature range | °C | -20 / +60 |
| Fluid temperature range | °C | -20 / +80 |
| Fluid viscosity range | cSt | 10 ÷ 400 |
| Fluid contamination degree | According to ISO 4406:1999 class 20/18/15 | |
| Recommended viscosity | cSt | 25 |
| Mass | kg | 0.15 |
| Surface treatment: electrolytic zinc covering | ISO 2081 - Fe/Zn12/A | |

HYDRAULIC SYMBOL

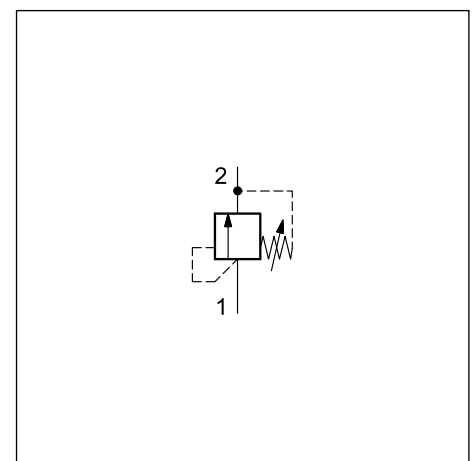



BIBUS SK, s.r.o
Trnavská 31, SK-94 901 Nitra

Tel.: 037/ 7777 911 Email: sale@bibus.sk
Fax.: 037/ 7777 999 http://www.bibus.sk

PLK08

SERIES 10

1 - IDENTIFICATION CODE

| | | | | | | | | | |
|---|---|---|----|---|---|----|---|--|--|
| P | L | K | 08 | . | / | 10 | / | | |
|---|---|---|----|---|---|----|---|--|--|

Pressure relief valve, direct operated

Cartridge type _____

Size _____

Pressure adjustment range: _____

035 = up to 35 bar (6 bar/turn)
070 = up to 70 bar (14 bar/turn)
140 = up to 140 bar (34 bar/turn)
210 = up to 210 bar (53 bar/turn)
280 = up to 280 bar (75 bar/turn)
350 = up to 350 bar (94 bar/turn)

Option:
K = Adjustment knob.
(omit for adjustment with hex socket screw)

Seals:
N = NBR seals for mineral oils (standard)
V = FPM seals for special fluids

Series No.
(the overall and mounting dimensions remain unchanged from 10 to 19)

2 - CHARACTERISTIC CURVES

(values obtained with viscosity of 36 cSt at 50 °C)

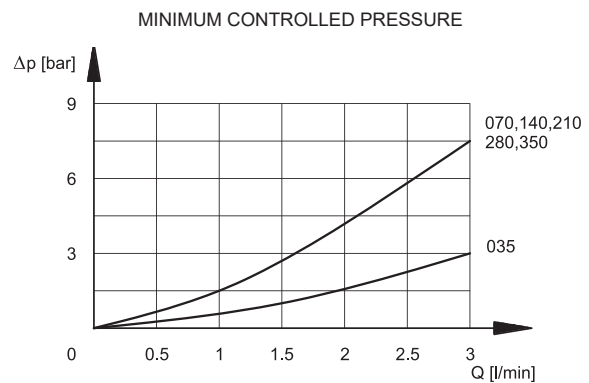
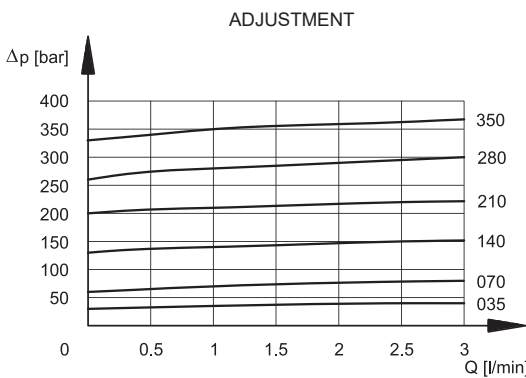

3 - HYDRAULIC FLUIDS

Use mineral oil-based hydraulic fluids HL or HM type, according to ISO 6743-4. For these fluids, use NBR seals (code N). For fluids HFDR type (phosphate esters) use FPM seals (code V). For the use of other kinds of fluid such as HFA, HFB, HFC, please consult our technical department. Using fluids at temperatures higher than 80 °C causes a faster degradation of the fluid and of the seals characteristics.

The fluid must be preserved in its physical and chemical characteristics.

4 - OVERALL AND MOUNTING DIMENSIONS

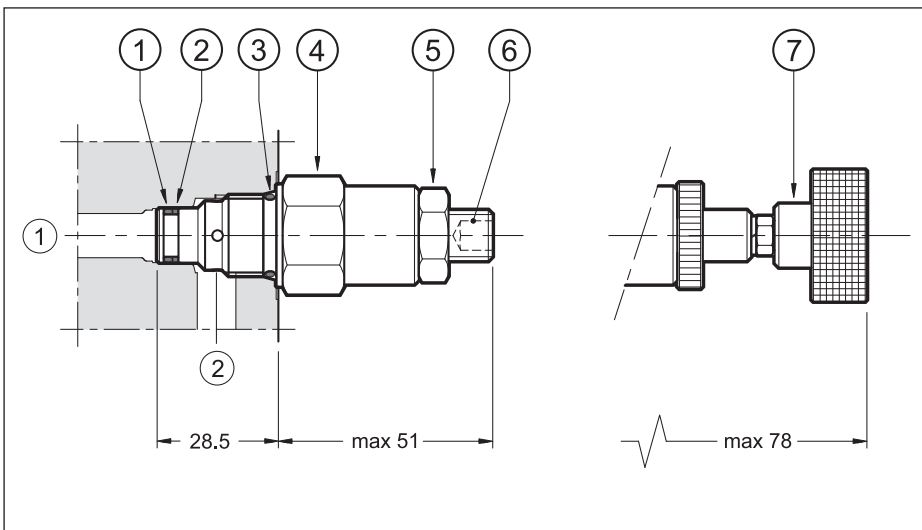

dimensions in mm

| | |
|---|---|
| 1 | OR type 2037 (9.25x1.78) 70 Shore |
| 2 | Parbak 8-012 (9.96x1.14x1.35) |
| 3 | OR type 3.908 (16.36x2.2) 70 Shore |
| 4 | Cartridge tightening: spanner 24 Tightening torque 50 Nm |
| 5 | Locking nut: spanner 19 |
| 6 | Socket hex adjustment screw: Hex key 6. Rotate clockwise to increase pressure |
| 7 | Adjustment knob: K |



DIPLOMATIC MS S.p.A.

via M. Re Depaolini 24 • 20015 PARABIAGO (MI) • ITALY

tel. +39 0331.895.111 • www.diplomatic.com • e-mail: sales.exp@diplomatic.com