

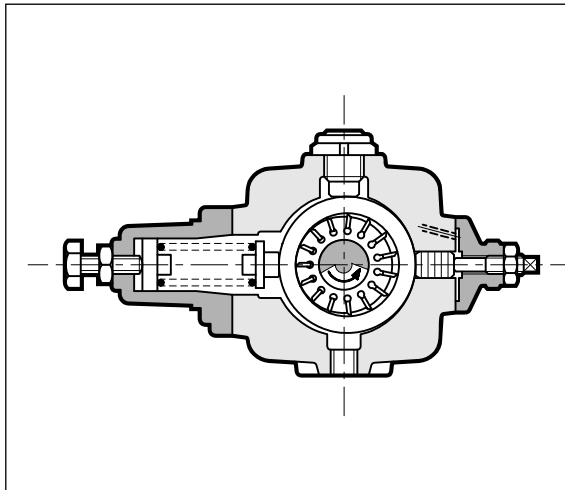

# PVD

## VARIABLE DISPLACEMENT VANE PUMPS WITH DIRECT PRESSURE ADJUSTER

### OPERATING PRINCIPLE



- The PVD pumps are variable displacement vane pumps with a mechanical type of pressure compensator.
- They allow instantaneous adjustment of the flow rate according to the circuit requirements. The consequence is that energy consumption is reduced and adequate in every phase of the cycle.
- The pump group is complete with hydrostatic axial compensation distribution plates that improve the volumetric efficiency and reduce wear of the components.
- The pressure compensator keeps the cam ring of the pumping group in the eccentric position with use of an adjustable load spring. When the delivery pressure equals the pressure corresponding to the spring setting, the cam ring is moved toward the center, adjusting the flow rate to the values required by the plant.
- In zero flow demand conditions, the pump delivers oil only to compensate any possible bleedings and pilotings, keeping the circuit pressure constant.
- The compensator response times are very low such as to allow elimination of the pressure relief valve.

### PERFORMANCE RATINGS (measured with mineral oil with viscosity of 36 cSt at 50°C)

PVD sizes		25	28	35	45	56	72	90	115	145
Geometric displacement (UNI ISO 3662)	cm <sup>3</sup> /rev	16	20	25	31,5	40	50	63	80	100
Actual displacement	cm <sup>3</sup> /rev	17,9	22,1	26,9	34,5	42,8	53,1	69	86,2	105,5
Maximum flow at 1450 rpm and p = 80 bar	l/min	25	29	36,2	45,6	58	72,5	91,3	116	145
Max working pressure	bar	120	100		100			80		
Pressure adjustment range	bar	20 ÷ 120	30 ÷ 100		30 ÷ 100			30 ÷ 80		
Maximum drain port pressure allowed	bar	1								
Rotation speed range	rpm	800 ÷ 1800								
Rotation direction		clockwise (seen from the outlet shaft side)								
Shaft loads		radial and axial loads are not allowed								
Max applicable torque on shaft:	version H	110	197		400			740		
	version K	70	-		-			-		
Mass	kg	7,3	12		32			44		

Ambient temperature range	°C	-20 / +50
Fluid temperature range	°C	-10 / +50
Fluid viscosity range		see paragraph 3.2
Recommended viscosity	cSt	22 ÷ 68
Degree of fluid contamination		see paragraph 3.3

### HYDRAULIC SYMBOL

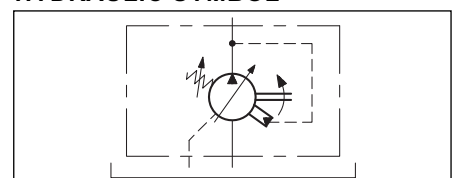



of the pump. Hence, use of a filter with  $\beta_{10} \geq 100$  is recommended.

If there is a filter installed on the suction line, be sure that the pressure at the pump inlet is not lower than the values specified in paragraph 12. The suction filter must be equipped with a by-pass valve and, if possible, with a clogging indicator.

#### 4 - PVD25 CHARACTERISTIC CURVES (obtained with viscosity of 36 cSt at 50°C)

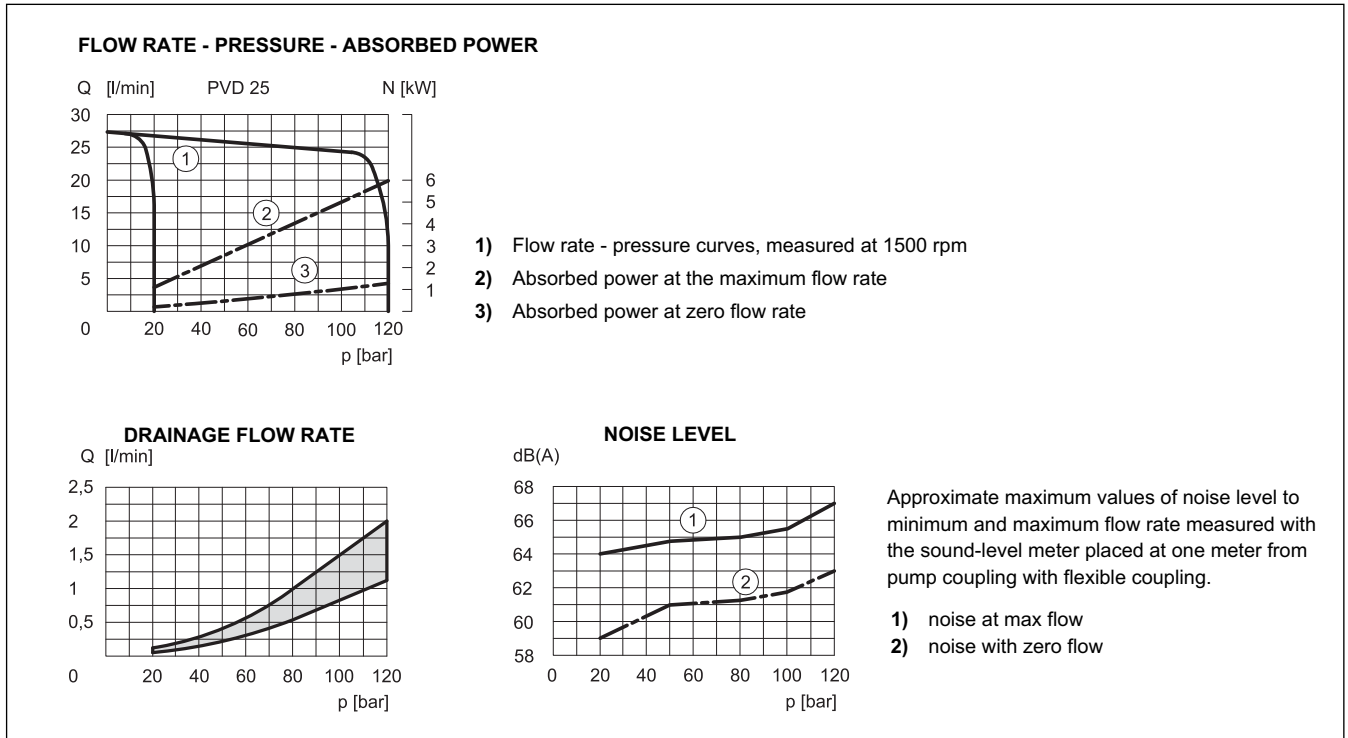

#### 5 - PVD28, PVD35 CHARACTERISTIC CURVES (obtained with viscosity of 36 cSt at 50°C)

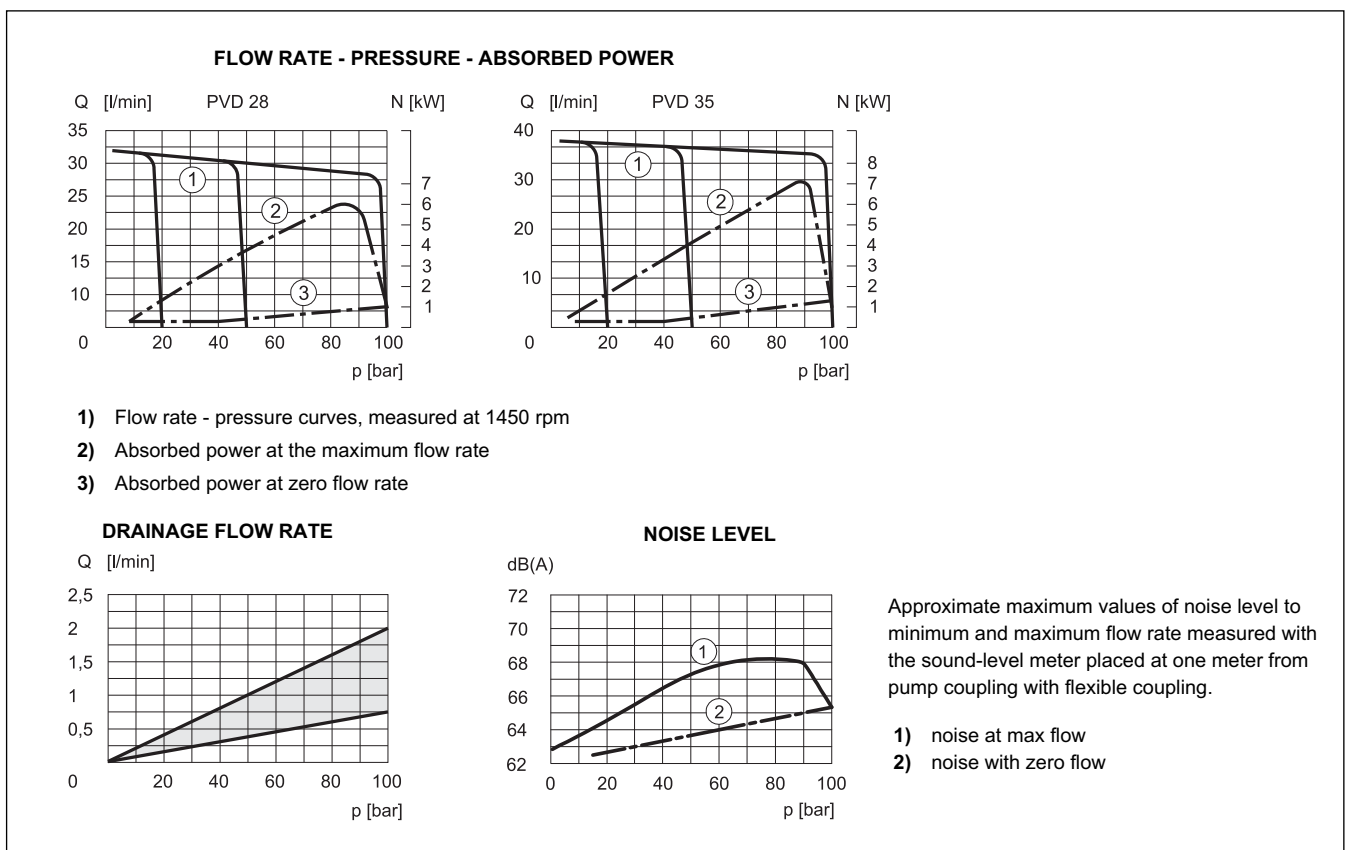

## 6 - PVD45, PVD56 and PVD72 CHARACTERISTIC CURVES (values obtained with mineral oil with viscosity of 36 cSt at 50°C)

### FLOW RATE - PRESSURE - ABSORBED POWER

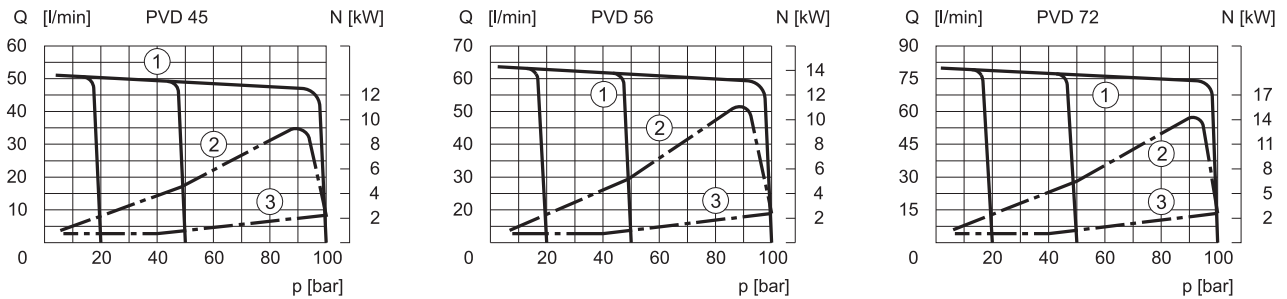

- 1) Flow rate - pressure curves, measured at 1450 rpm
- 2) Absorbed power at the maximum flow rate
- 3) Absorbed power at zero flow rate

### DRAINAGE FLOW RATE

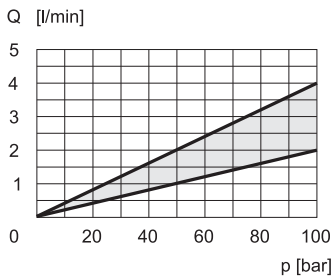

### NOISE LEVEL

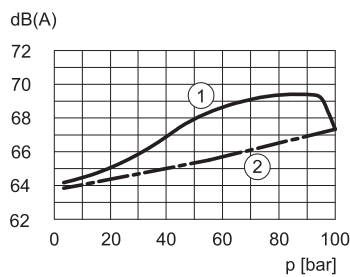

Approximate maximum values of noise level to minimum and maximum flow rate measured with the sound-level meter placed at one meter from pump coupling with flexible coupling.

- 1) noise at max flow
- 2) noise with zero flow

## 7 - PVD90, PVD115 and PVD145 CHARACTERISTIC CURVES (values obtained with viscosity of 36 cSt at 50°C)

### FLOW RATE - PRESSURE - ABSORBED POWER

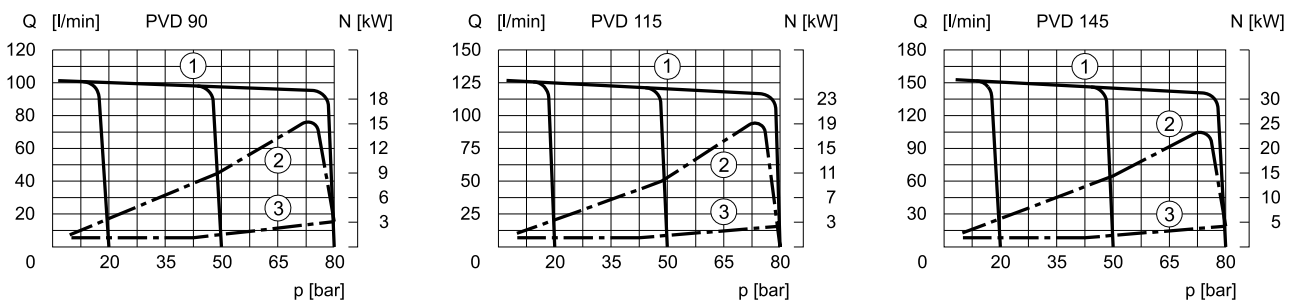

- 1) Flow rate - pressure curves, measured at 1450 rpm
- 2) Absorbed power at the maximum flow rate
- 3) Absorbed power at zero flow rate

### DRAINAGE FLOW RATE

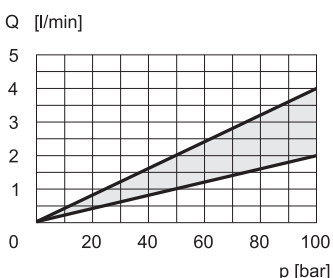

### NOISE LEVEL

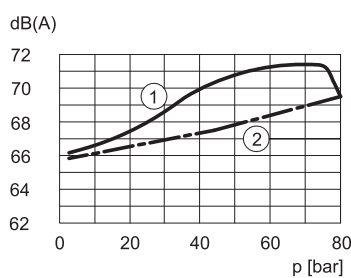

Approximate maximum values of noise level to minimum and maximum flow rate measured with the sound-level meter placed at one meter from pump coupling with flexible coupling.

- 1) noise at max flow
- 2) noise with zero flow

8 - PVD25 OVERALL AND MOUNTING DIMENSIONS

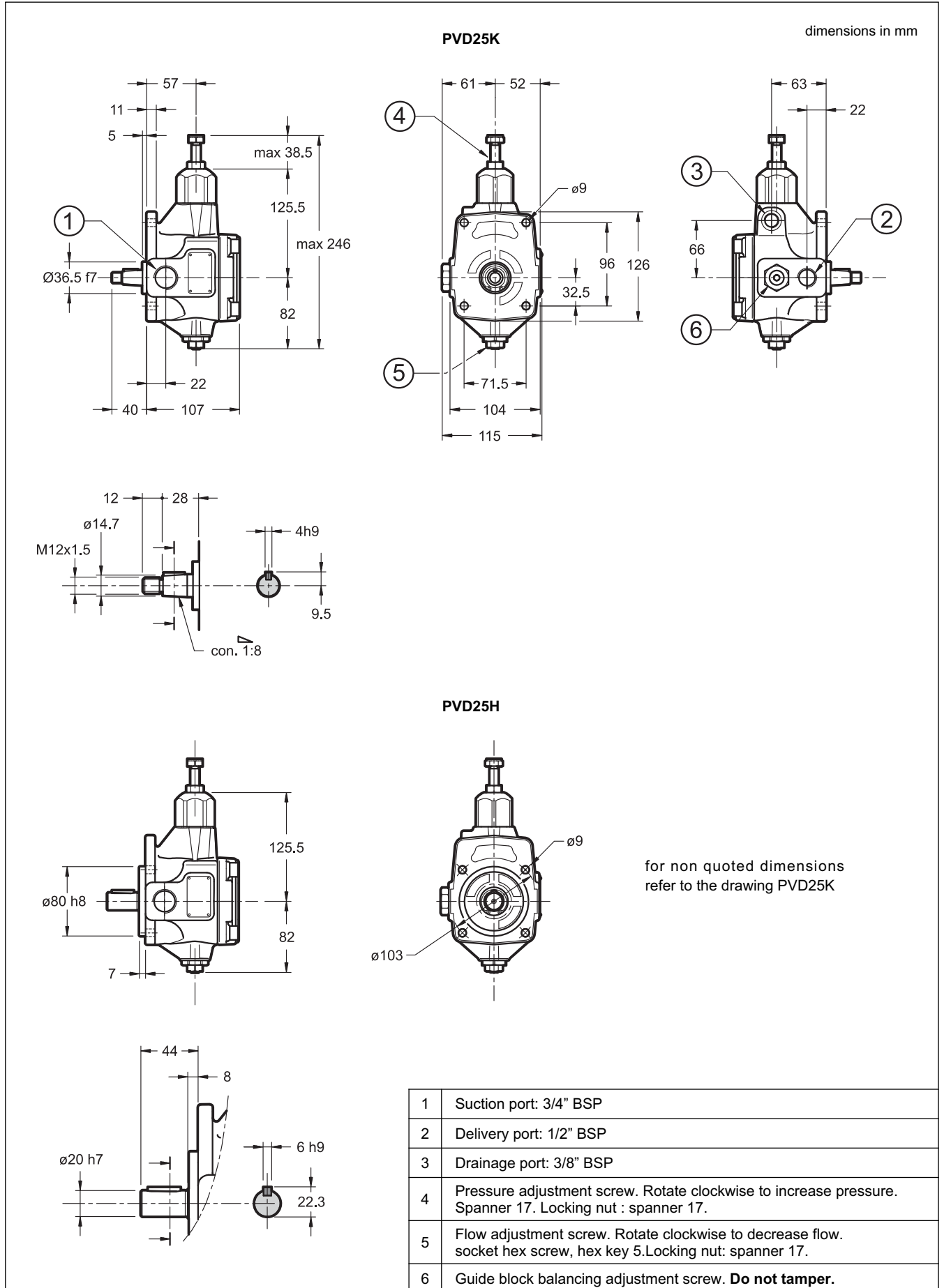

9 - PVD28, PVD35 OVERALL AND MOUNTING DIMENSIONS

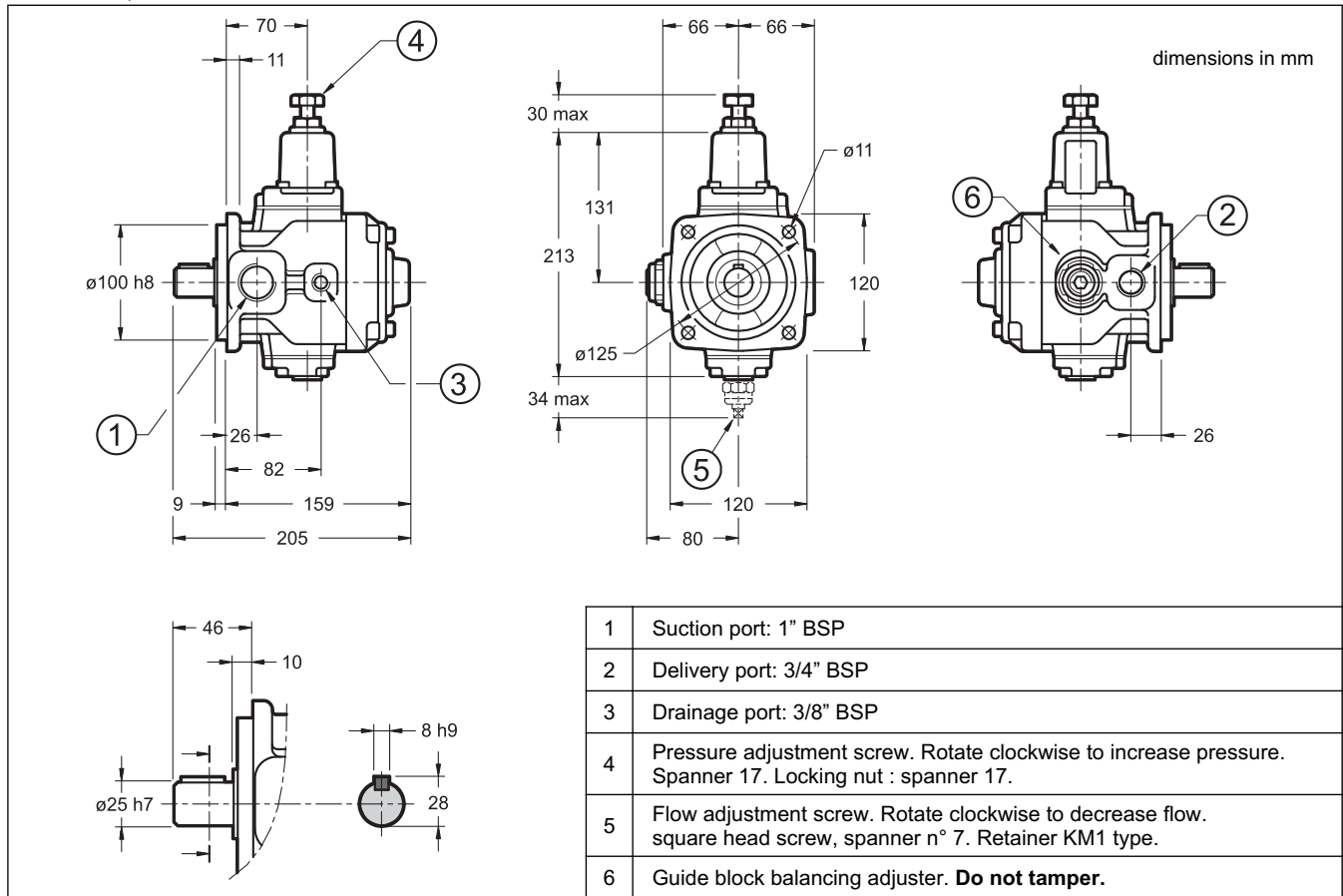

10 - PVD45, PVD56 AND PVD72 OVERALL AND MOUNTING DIMENSIONS

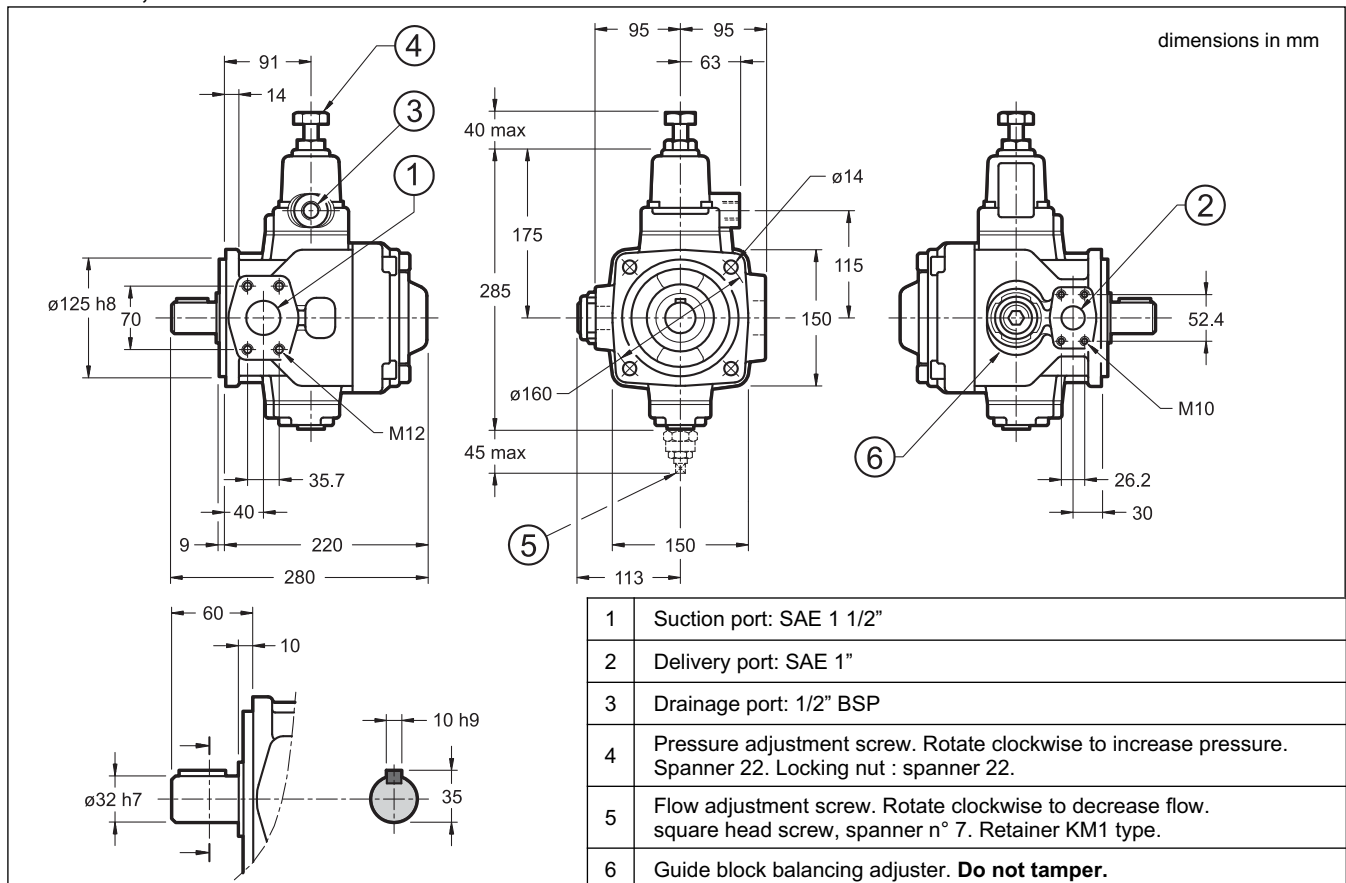

11 - PVD90, PVD115 AND PVD145 OVERALL AND MOUNTING DIMENSIONS

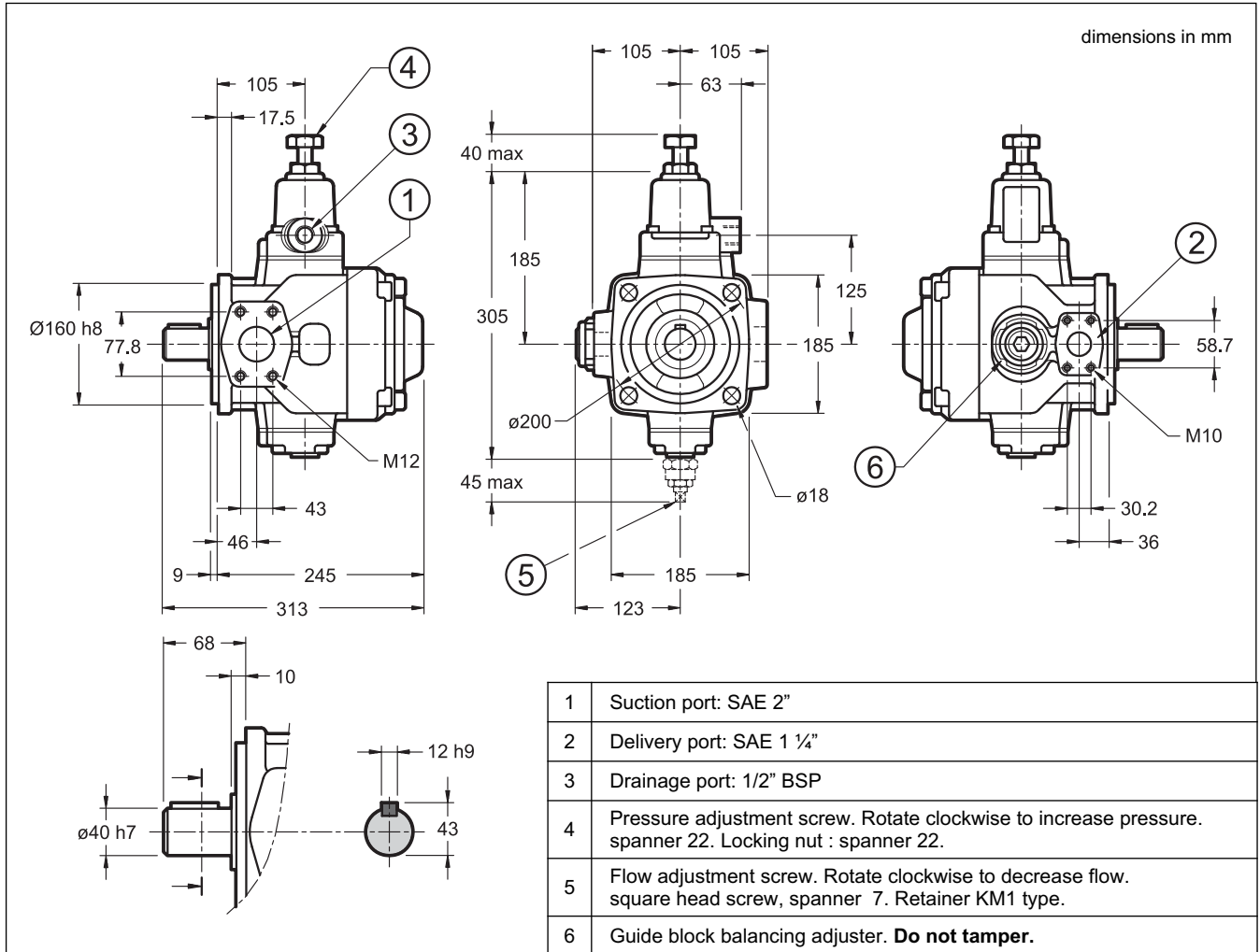

12 - INSTALLATION

- The instruction manual for the installation and commissioning of the pumps is always included in the packaging with the pump. Observe restrictions in this document and follow the instructions.
- The PVD pumps up to size 35 can be installed with the axis oriented in any position. For other sizes the pump must be installed with the axis in horizontal position and with the pressure compensator upward.
- The motor-pump connection must be carried out directly with a flexible coupling. Couplings that generate axial or radial loads on the pump shaft are not allowed.
- The suction line must be short, with end pipe cut at 45 ° and suitably sized: the minimum cross-section of the tube should reflect that of the thread on the inlet port of the pump to facilitate the oil flow. Bends and restrictions or an excessive line length can impair correct operation of the pump.  
Suction pressure should be between 0.8 and 1.5 bar absolute
- The drainage pipe must be connected directly to the tank by a line separate from other discharges, located as far as possible from the suction line and lengthened to below the minimum oil level in order to avoid foaming.
- The tank must be suitably sized in order to allow the cooling of the fluid. It should be good that the fluid in the tank do not exceed 50°C. If necessary, consider the installation of a heat exchanger on the drain line.
- The pump start up must be done in full displacement (P→T) with flow to the tank, to purge the air.
- It's essential that the difference between the fluid temperature and the ambient (pump body) temperature doesn't exceed 20°C
- The pumps are usually placed directly upon the oil tank. Flooded suction port installation of the pumps is recommended in the case of circuits with high flow rates and pressures.





14 - CONNECTION FLANGES

dimensions in mm

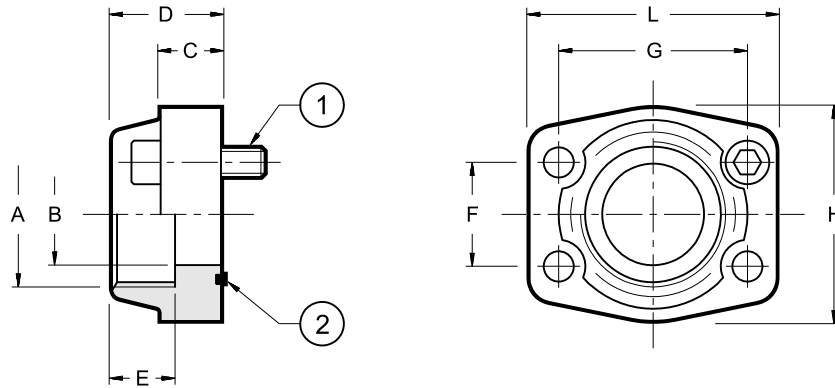

The fastening bolts and the O-Rings must be ordered separately.

flange code	flange description	P <sub>max</sub> [bar]	ØA	ØB	C	D	E	F	G	H	L	(1) bolts	(2)
0610713	SAE - 1"	345	1" BSP	25	18	38	22	26.2	52.4	22	70	N. 4	OR 4131 (32.93x3.53)
0610720	SAE - 1 1/4"	276	1 1/4" BSP	32	21	41	22	30.2	58.7	68	79	SHC M10x35	OR 4150 (37.69x3.53)
0610714	SAE - 1 1/2"	207	1 1/2" BSP	38	25	44	24	35.7	70	78	93	N. 4	OR 4187 (47.22x3.53)
0610721	SAE - 2"	207	2" BSP	51	25	45	30	43	77.8	90	102	SHC M12x45	OR 4225 (56.74x3.53)



**DIPLOMATIC OLEODINAMICA S.p.A.**  
20015 PARABIAGO (MI) • Via M. Re Depaolini 24  
Tel. +39 0331.895.111  
Fax +39 0331.895.339  
[www.diplomatic.com](http://www.diplomatic.com) • e-mail: [sales.exp@diplomatic.com](mailto:sales.exp@diplomatic.com)

