

ENGINEERING
TOMORROW

Danfoss

Technical Information

D-Series Cast Iron Gear Motors

Including Fan Drive

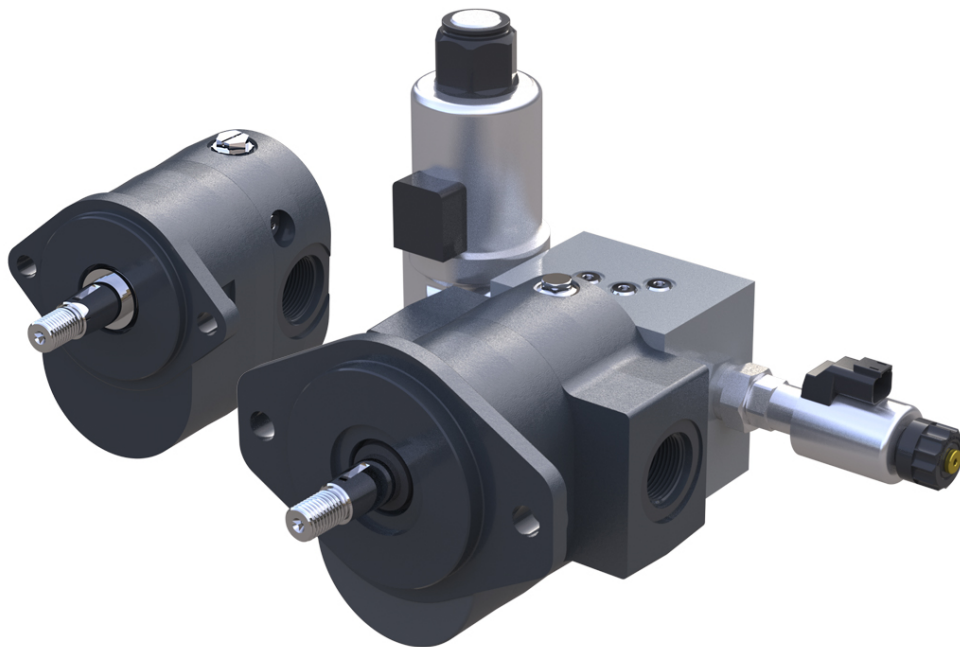

Revision history*Table of revisions*

Date	Changed	Rev
March 2021	Updated product code information for anti-cavitation / shock valve function	0104
May 2020	Updated table in Dimension drawings section: Standard motor	0103
December 2019	Dimensions for standard motor change.	0102
October 2019	First edition	0101

Contents

General information

Overview.....	5
Features and Benefits.....	5
Fan drive motors.....	5
Features.....	6
Benefits.....	6
System schematics.....	7
Product features.....	8
Technical specifications.....	9
Fluid specifications.....	9
Sizing equations.....	10

Operating Parameters

Overview.....	11
Pressure.....	11
Peak pressure.....	11
Rated pressure.....	11
System pressure.....	11
Back pressure.....	11
Case drain pressure.....	11
Temperature and viscosity.....	12
Temperature.....	12
Viscosity.....	12
Speed.....	12
Hydraulic fluid.....	12
Filtration.....	13
Filters.....	13
Selecting a filter.....	13
Reservoir.....	13
Line sizing.....	14
Motor life.....	14
Motor shaft connection.....	14
Radial and axial loading.....	15

Product code

Model code.....	16
Fan drive motor code example.....	16
A - Sense of rotation.....	16
B1 - Displacement.....	16
B2 - Input shaft.....	16
C - Mounting flange.....	17
D1 - Cover.....	17
D2 - Rear cover port option.....	18
D - Rear cover availability.....	18
E - Relief valve availability.....	19
F - Anti-cavitation/shock valve function.....	20
G - Integrated reversing modulating function.....	20
J - Name plate.....	21
K - Name plate.....	21

Dimension drawings

Mounting flanges.....	23
Shaft options.....	24
Port options.....	27
Selecting port options.....	28
Integrated reversing motor with proportional relief and shock/anti-cavitation valves.....	29
Features and benefits.....	29
Technical data.....	29
Integrated reversing function.....	30

Options

Contents

Standard relief valve.....	31
Anti-cavitation check valve.....	32
Proportional relief valve with anti-cavitation valve.....	33
Valve settings.....	34
Performance graphs.....	35
Valve settings.....	36
Performance graphs.....	36
Hall effect speed sensor.....	37

Dimension drawings

Fan drive motor.....	39
Standard motor.....	39
Standard motor with split flange ports.....	40
Integrated reversing motor with proportional relief and shock/anti-cavitation valves.....	42

Performance data

Motor performance graphs.....	44
-------------------------------	----

General information

Overview

The Danfoss D Series fixed displacement gear motor has been specifically designed for demanding mobile equipment applications where maximum performance is required at peak power levels and operating temperatures.

The D Series motor is available in displacements of 17.6cm³ to 48,3cm³ [1.08 in³ to 2.95 in³]. This motor delivers consistent efficiency across the entire operating range of pressure, speed, and temperature; all in an industry-leading package size that maximizes power density.

Features and Benefits

- High strength cast iron construction allows consistently efficient performance in continuous operation at 276 bar (4000 psi) and 110°C (230°F).
- Custom engineered shaft bearings and dual pressure-balanced thrust plates optimize internal bearing lubrication, allowing for high starting torque and long life with fluid viscosities as low as 8 mm²/sec (cSt) [52 SUS].
- Compact three-piece design with bearings located in the front flange and rear cover minimizes the overall package length and increases radial load carrying capability, eliminating the need for outrigger bearings on most applications.
- Variety of integrated valve options make the D Series motor ideally suited for high performance fan drive applications.

Fan drive motors

D Series cast iron motors complement the Danfoss portfolio of fan drive products. Including aluminum and cast iron pumps and motors, piston pumps and motors, valves and microcontrollers, you can apply the Danfoss range in various combinations to create high-performance fan drive systems. D series motors with integrated reversing and proportional relief valves are PLUS+1[®] Compliant for easy plug-and-perform™ installations and offer precise control of fan speed to optimize engine cooling performance.

Quick reference chart: Fan drive motors

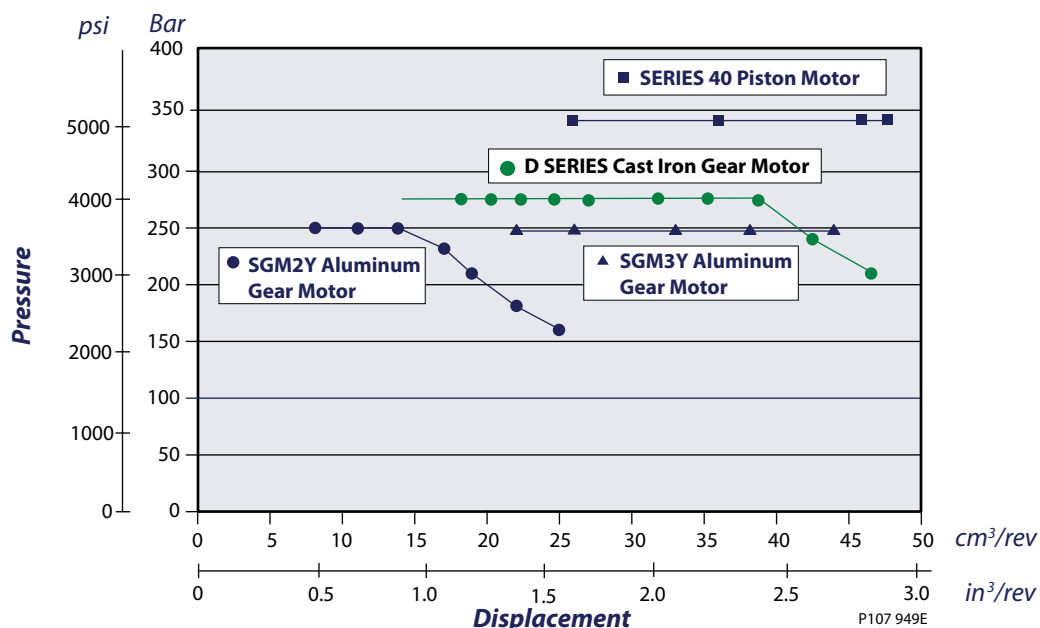

General information

Features

Quality components and construction

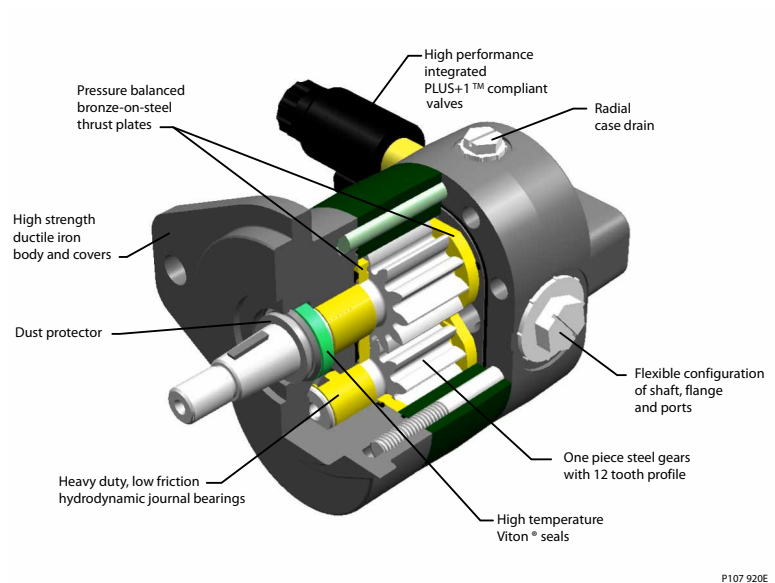

Benefits

- Pressure-balanced thrust plates for improved efficiency at extreme pressures and temperatures
- High-temperature Viton® seals for today's hotter running machines
- Three-piece ductile iron construction for increased durability, increased power density, with reduced adverse efficiency effects at high temperatures
- High quality steel backed bronze bearings for maximum pressure handling capacity, located in the front flange, allowing extended radial loading capacity without an external roller bearing
- Output shaft external dust protector to protect the oil seal from contamination damage
- Available side or rear ports, SAE A or B flange, with a variety of shafts for versatility
- Integrated, normally-closed electrohydraulic proportional relief valve option for today's high-performing fan systems

General information

System schematics

Gear pump/gear motor system with electronic control

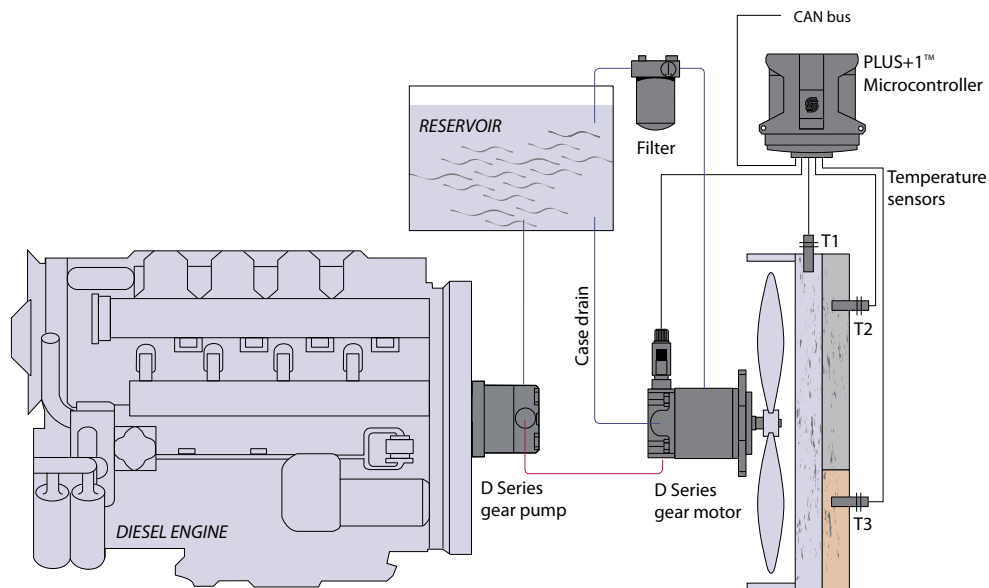

P107 929E

Piston pump/gear motor system with electronic control

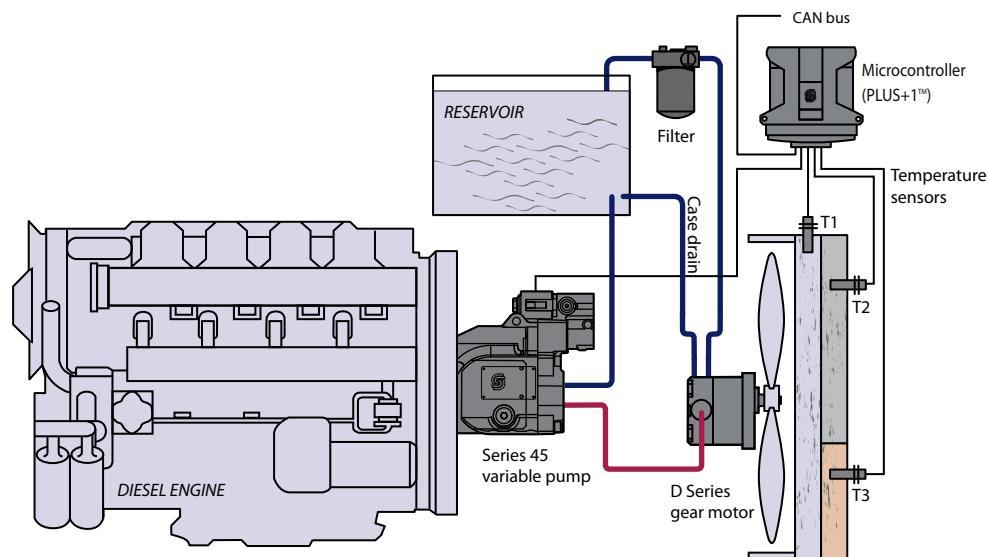

P107 931E

General information

Gear pump/gear motor system with integrated reversing valve

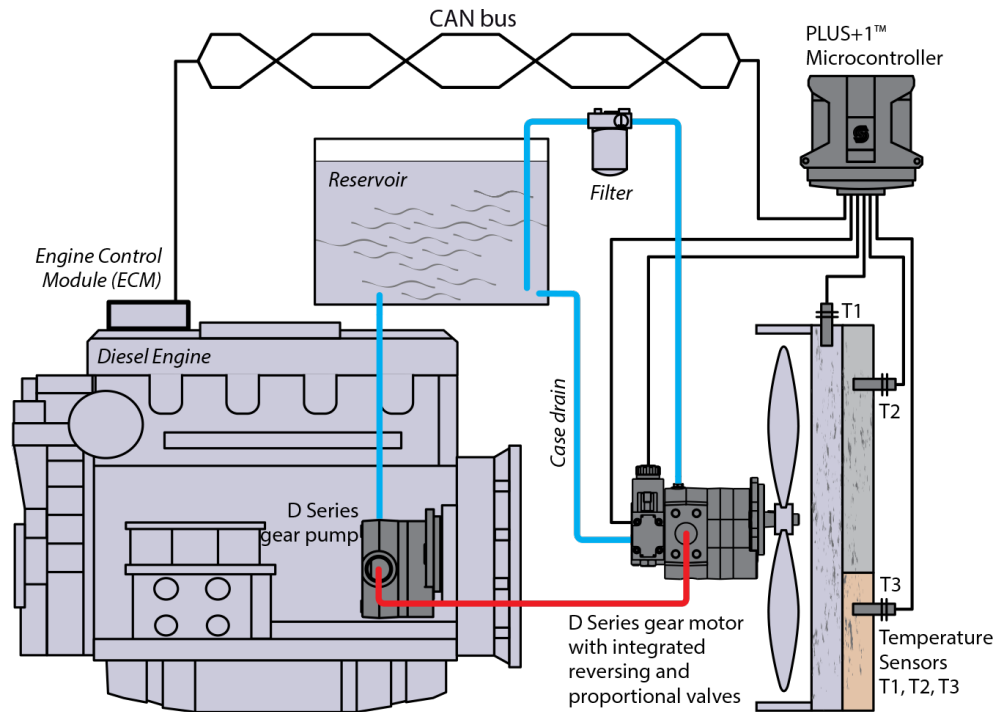

P108 248E

Product features

Features	Descriptions
Construction	Heavy duty ductile iron 3-piece construction
Displacements	17.6 to 48.3 cm ³ [1.08 to 2.95 in ³ /rev]
Continuous Pressure	276 bar [4000 psi] to 40.9 cm ³ [2.50 in ³]
Peak Pressure	303 bar [4400 psi] to 40.9 cm ³ [2.50 in ³]
Speed	600 to 3400 min ⁻¹ (rpm) - up to 40.9 cm ³ [2.50 in ³]
Mounting	SAE A two bolt, SAE B two bolt
Shaft (types)	SAE straight keyed, 1:8 tapered keyed, splined
Fluid viscosity	8 mm ² /sec (cSt) [52 SUS] minimum, 1600 mm ² /sec (cSt) [7500 SUS] maximum
Filtration requirement	22/18/13 ISO 4406 at motor inlet
Inlet options	SAE O-ring boss, SAE split flange
Fluids	Petroleum/mineral based
Operating temperature	-40°C [-40°F] minimum for cold start 110°C [230°F] normal operating conditions 115°C [239°F] peak intermittent
Integrated valve options	Proportional relief valve, normally closed, 12 Vdc and 24 Vdc Two position directional control valve, 12 Vdc and 24 Vdc Relief valve Anti-cavitation check valve

General information

Technical specifications

Technical data for D Motors

Ratings	Units	17	19	21	23	25	29	32	36	38	41	45
Displacement	cm ³ /rev	17.6	19.9	22.4	23.2	26.2	30.6	34.4	38.6	40.9	42.9	48.3
	in ³ /rev	1.08	1.22	1.37	1.42	1.6	1.87	2.1	2.36	2.5	2.62	2.95
Rated pressure	bar	276	276	276	276	276	276	276	276	276	241	210
	psi	4000	4000	4000	4000	4000	4000	4000	4000	4000	3495	3045
Peak pressure	bar	303	303	303	303	303	303	303	303	303	265	231
	psi	4400	4400	4400	4400	4400	4400	4400	4400	4400	3843	3350
Speed at rated pressure	maximum	3400	3400	3400	3400	3400	3400	3400	3400	3400	3000	3000
	minimum*	1000	600	600	600	600	600	600	600	600	600	600
Start speed at 1000 PSI	rpm	400	400	400	400	400	400	400	400	400	400	400
Standard Weight	kg	8.53	8.66	8.80	8.94	9.07	9.38	9.53	9.84	9.93	10.16	10.43
	lb	18.8	19.1	19.4	19.7	20.0	20.7	21.0	21.7	21.9	22.4	23.0
Mass moment of inertia of internal rotating components	x10 ⁻⁶ kg·m ²	127	138	146	156	172	191	206	228	239	255	276
	x10 ⁻⁶ slug·ft ²	94	102	107	115	127	141	152	168	176	188	204
Theoretical torque at rated pressure	N·m	65.7	73.4	79.2	87.0	98.2	112.1	122.9	139.6	146.9	138.4	132.4
	lbf·ft	48.5	54.2	58.4	64.2	72.4	82.7	90.7	102.9	108.3	102.1	97.6
Theoretical power at rated speed	kW	23.4	26.1	28.2	31.0	35.0	39.9	43.8	49.7	46.1	43.5	41.6
	hp	31.2	34.9	37.6	41.3	46.6	53.2	58.4	66.3	61.1	58.0	55.5
Case drain pressure	bar	5.0	5.0	5.0	5.0	5.0	5.0	5.0	5.0	5.0	5.0	5.0
	psi	72.5	72.5	72.5	72.5	72.5	72.5	72.5	72.5	72.5	72.5	72.5

* minimum speed at maximum pressure

Fluid specifications

Parameter	Unit	Minimum	Continuous	Maximum
Viscosity	mm ² /sec (cSt) [SUS]	8 [52]	10 - 100 [59 - 456]	1600 [7500]
Temperature	°C [°F]	-40 [-40]	110 [230]	115 [239]
Cleanliness	n/a	ISO 4406 Class 22/18/13 or better		
Filtration efficiency	charge filtration	$\beta_{15-20} = 75 (\beta_{10} \geq 10)$		

Ratings are based on operation with premium petroleum-based hydraulic fluids containing oxidation, rust, and foam inhibitors.

General information

Sizing equations

Use these formulas to determine the nominal motor size for a specific application.

Based on SI units

$$\text{Input flow } Q = \frac{V_g \cdot n}{1000 \cdot \eta_t} \quad (\text{l/min})$$

$$\text{Output torque } M = \frac{V_g \cdot \Delta p \cdot \eta_m}{20 \cdot \pi} \quad (\text{N}\cdot\text{m})$$

$$\text{Output power } P = \frac{Q \cdot \Delta p \cdot \eta_t}{600} \quad (\text{kW})$$

$$\text{Motor speed } n = \frac{Q \cdot 1000 \cdot \eta_v}{V_g} \quad (\text{min}^{-1}(\text{rpm}))$$

Based on US units

$$\text{Input flow } Q = \frac{V_g \cdot n}{231 \cdot \eta_t} \quad (\text{US gal/min})$$

$$\text{Output torque } M = \frac{V_g \cdot \Delta p \cdot \eta_m}{2 \cdot \pi} \quad (\text{lb}\cdot\text{ft})$$

$$\text{Output power } P = \frac{Q \cdot \Delta p \cdot \eta_t}{1714} \quad (\text{hp})$$

$$\text{Motor speed } n = \frac{Q \cdot 231 \cdot \eta_v}{V_g} \quad (\text{min}^{-1}(\text{rpm}))$$

Variables SI units [US units]

V_g	= Displacement per revolution	cm^3/rev [in^3/rev]
p_o	= Outlet pressure	bar [psi]
p_i	= Inlet pressure	bar [psi]
Δp	= $p_o - p_i$ (system pressure)	bar [psi]
n	= Speed	min^{-1} (rpm)
η_v	= Volumetric efficiency	
η_m	= Mechanical efficiency	
η_t	= Overall efficiency ($\eta_v \cdot \eta_m$)	

Operating Parameters

Overview

Definitions of the D Series operating parameters appear here. Consult your Danfoss representative for applications running outside of these parameters.

Pressure

Peak pressure

Peak pressure is the highest intermittent pressure allowed.

The relief valve overshoot (reaction time) determines peak pressure. It is assumed to occur for less than 100 ms. The accompanying illustration shows peak pressure in relation to rated pressure and reaction time (100 ms maximum).

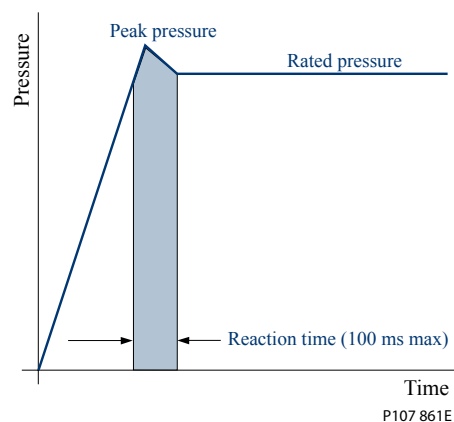

Rated pressure

Rated pressure is the average, regularly occurring operating inlet pressure that should yield satisfactory product life. The maximum machine load at the motor shaft determines rated pressure.

System pressure

System pressure is the differential between the inlet and outlet ports.

It is a dominant operating variable affecting hydraulic unit life. High system pressure, resulting from high load at the motor shaft, reduces expected life. System pressure must remain at, or below, rated pressure during normal operation to achieve expected life.

Back pressure

The hydraulic load downstream of the motor determines the back pressure. The D Series motor can work with back pressure up to 100% of the maximum rated inlet pressure.

Case drain pressure

Case drain pressure is the pressure in the case drain line. Route case drain plumbing directly to the reservoir to keep the case drain pressure as low as possible. Maximum continuous case drain pressure allowed is 5 bar [72.5 psi].

Operating Parameters

Temperature and viscosity

Temperature and viscosity requirements must be concurrently satisfied.

Temperature

High temperature limits apply at the inlet port of the motor. Ensure the motor runs at or below the maximum continuous temperature.

Cold oil, generally, does not affect the durability of motor components. It may affect the ability of oil to flow and transmit power. For this reason, keep the temperature at 16°C [61 °F] above the pour point of the hydraulic fluid.

Minimum (cold start) temperature relates to the physical properties of component materials.

Continuous temperature is the temperature at or below which you may expect normal motor life.

Maximum temperature is the highest temperature that is tolerable by the machine for a transient/limited time. (Duty cycle 1% or less)

Viscosity

Minimum viscosity occurs only during brief occasions of maximum fluid temperature and severe duty cycle operation. It's the minimum acceptable viscosity to guarantee the motor life. (Duty cycle 1% or less)

Maximum viscosity occurs only during cold start at very low temperatures. It is the upper limit of viscosity that allows the motor to start.

Continuous viscosity is the viscosity range at which you may expect normal motor.

Speed

Maximum speed is the limit for a particular gear motor when operating at rated pressure. It is the highest speed at which you may expect normal life.

The lower limit of operating speed is the **minimum speed**.

Minimum speed increases as operating system pressure increases. When operating under higher pressures, a higher minimum speed must be maintained, as shown.

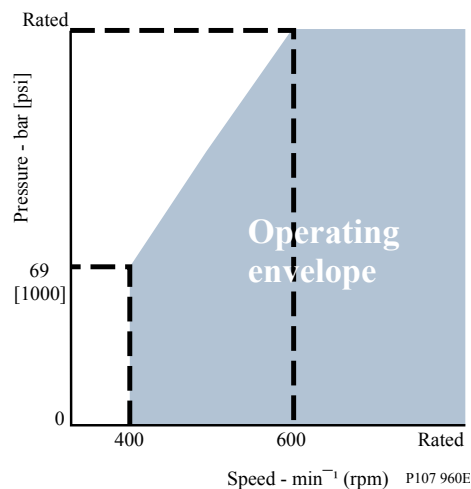

Hydraulic fluid

Ratings and data for gear motors are based on operation with premium hydraulic fluids containing oxidation, rust, and foam inhibitors. These fluids must possess good thermal and hydrolytic stability to prevent wear, and corrosion of internal components. Use petroleum/mineral-based fluids. Ensure only clean fluid enters the hydraulic system.

Operating Parameters

! Caution

Never mix hydraulic fluids.

Filtration

Filters

Use a filter that conforms to Class 22/18/13 of ISO 4406 (or better). It may be on the motor outlet (discharge filtration) or inlet (pressure filtration).

Selecting a filter

When selecting a filter, please consider:

- Contaminant ingress rate (determined by factors such as the number of actuators used in the system)
- Generation of contaminants in the system
- Required fluid cleanliness
- Desired maintenance interval
- Filtration requirements of other system components

Measure filter efficiency with a Beta ratio (β_x). β_x ratio is a measure of filter efficiency defined by ISO 4572. It is the ratio of the number of particles greater than a given diameter (in microns) upstream of the filter to the number of these particles downstream of the filter.

- For discharge filtration with controlled reservoir ingress, use a $\beta_{35-45} = 75$ filter
- For pressure filtration, use a filtration with an efficiency of $\beta_{10} = 75$

The filtration requirements for each system are unique. Evaluate filtration system capacity by monitoring and testing prototypes.

Fluid cleanliness level and β_x ratio

Fluid cleanliness level (per ISO 4406)	Class 22/18/13 or better
β_x ratio (discharge filtration)	$\beta_{35-45} = 75$ and $\beta_{10} = 2$
β_x ratio (pressure or return filtration)	$\beta_{10} = 75$
Recommended inlet screen size	100 – 125 μm [0.004 – 0.005 in]

Reservoir

The **reservoir** provides clean fluid, dissipates heat, removes entrained air, and allows fluid volume changes associated with fluid expansion and cylinder differential volumes. A correctly sized reservoir accommodates maximum volume changes during all system operating modes. It promotes de-aeration of the fluid as it passes through, and accommodates a fluid dwell-time between 60 and 180 seconds, allowing entrained air to escape.

Minimum reservoir capacity depends on the volume required to cool and hold the oil from all retracted cylinders, allowing for expansion due to temperature changes. A fluid volume of 1 to 3 times the pump output flow (per minute) is satisfactory. The minimum reservoir capacity is 125% of the fluid volume.

Install the suction line above the bottom of the reservoir to take advantage of gravity separation and prevent large foreign particles from entering the line. Cover the line with a 100-125 micron screen. The pump should be below the lowest expected fluid level.

Put the return-line below the lowest expected fluid level to allow discharge into the reservoir for maximum dwell and efficient deaeration. A baffle (or baffles) between the return and suction lines promotes deaeration and reduces fluid surges.

Operating Parameters

Line sizing

Choose pipe sizes that accommodate minimum fluid viscosity to reduce system noise, pressure drops and overheating in order to maximize system life and performance. Line velocity should not exceed 6.0 m/s [20.0 ft/s]. Route case drain line direct to tank.

Most systems use hydraulic oil containing 10% dissolved air by volume. Over-aeration, or entrained air is the result of flow line restrictions, where the dissolved air comes out of solution, or when air is allowed to leak into the hydraulic circuit. These include inadequate pipe sizes, sharp bends, or elbow fittings, causing reduction of flow-line cross-sectional area. This problem will not occur if these circuit recommendations are followed, rated speed requirements are maintained, and reservoir size and location are adequate.

Motor life

Motor life is a function of speed, system pressure, and other system parameters (such as fluid quality and cleanliness).

All Danfoss gear motors use hydrodynamic journal bearings that rely on an oil film between the gear shaft and bearing surfaces at all times. You can expect long life when this film is sustained through proper system maintenance and operating within recommended limits.

A B10 bearing life expectancy number is generally associated with rolling element bearings. It does not exist for hydrodynamic bearings.

High pressure impacts motor life. When submitting an application for review, provide machine duty cycle data that includes percentages of time at various loads and speeds. We strongly recommend a prototype testing program to verify operating parameters and their impact on life expectancy before finalizing any system design.

Motor shaft connection

Shaft options for gear motors include tapered, splined, and parallel shafts.

Plug-in drives, with a splined shaft, can impose severe radial loads when the mating spline is rigidly supported. Increasing spline clearance does not alleviate this condition.

Use plug-in drives only if the concentricity between the mating spline and pilot diameter is within 0.1 mm [0.004 in]. Lubricate the drive by flooding with oil. A three-piece coupling minimizes radial or thrust shaft loads.

Motor shaft connection

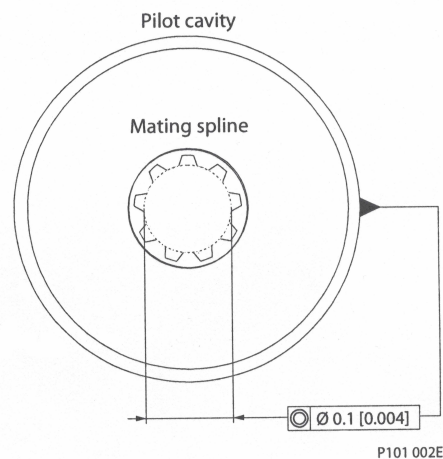

To avoid spline shaft damage, use carburized and hardened steel couplings with 80-82 HRA surface hardness.

Operating Parameters

Radial and axial loading

External shaft loads may have an effect on bearing life, and may affect motor performance depending on several factors such as load position and orientation, operating pressure, oil viscosity and motor speed.

D-motors are capable of carrying most plastic fans up to 11.75 kg (26 lbm) at rated pressure and speed. For any other application where radial and/or axial shaft loads are present, please fill in the Motor shaft load data form and contact your Danfoss representative for technical assistance.

Shaft loading

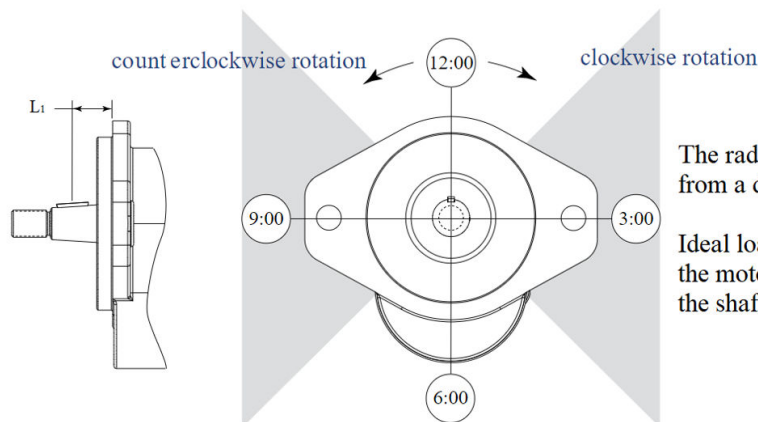

The radial loading angle α is acting from a direction towards the shaft.

Ideal loading is 12:00, or from above the motor and directed downward at the shaft.

P107 928F

Motor shaft load data form

Item	Value	Based on SI or US units	
Motor displacement		<input type="checkbox"/> cm ³ /rev	<input type="checkbox"/> in ³ /rev
Rated system pressure		<input type="checkbox"/> bar	<input type="checkbox"/> PSI
Peak pressure			
Motor shaft rotation		<input type="checkbox"/> left	<input type="checkbox"/> right
Motor minimum speed		min ⁻¹ (RPM)	
Motor maximum speed			
Radial load		<input type="checkbox"/> N	<input type="checkbox"/> lbf
Angular orientation from 12:00 (α)		12:00 - 11:59	
Axial load		<input type="checkbox"/> N	<input type="checkbox"/> lbf
Distance from flange (L_1)		<input type="checkbox"/> mm	<input type="checkbox"/> in

Product code
Model code
Fan drive motor code example
DEMR-17TY-AA-B107-P1AB-A000-N000-AN-NNN

A Right hand rotation, **B** 17 cm³, SAE 1:8 taper shaft, **C** SAE A two bolt mounting, **D** 7/8-14 ports, idler side drain, **E** 12 Vdc proportional relief valve, 25 US gal/min or less at 172 bar curve, **F** anti-cavitation valve.

A			B1	B2	C	D1	D2	E	F	G	J	K
D	E	M										

A - Sense of rotation

A			B1	B2	C	D1	D2	E	F	G	J	K
D	E	M	•									

Sense of rotation

Code	Description
B	Bidirectional rotation (reversing valve)
L	Left hand rotation (CCW)
R	Right hand rotation (CW)

B1 - Displacement

A			B1	B2	C	D1	D2	E	F	G	J	K
D	E	M	•	•								

Displacement

Code	Description
17	17.6 cm ³ /rev [1.07 in ³ /rev]
19	19.9 cm ³ /rev [1.21 in ³ /rev]
21	22.4 cm ³ /rev [1.37 in ³ /rev]
23	23.2 cm ³ /rev [1.42 in ³ /rev]
25	26.2 cm ³ /rev [1.60 in ³ /rev]
29	30.6 cm ³ /rev [1.87 in ³ /rev]
32	34.4 cm ³ /rev [2.10 in ³ /rev]
36	38.6 cm ³ /rev [2.36 in ³ /rev]
38	40.9 cm ³ /rev [2.50 in ³ /rev]
41	42.9 cm ³ /rev [2.62 in ³ /rev]
45	48.3 cm ³ /rev [2.95 in ³ /rev]

B2 - Input shaft

A			B1	B2	C	D1	D2	E	F	G	J	K
D	E	M		•	•							

Product code
Input shaft

Code	Description
PB	SAE 22mm [7/8in] dia. X 41mm [1.62in] Extension, 1/4in key , with key
PW	SAE 22mm [7/8in] dia. X 51mm [2in] Extension, 1/4in key , with key
TY	SAE 1:8 taper, 22mm [7/8in] dia. x 59mm [2.34in] Extension, 5/8-18x21mm [.81in] external thread with #8 Woodruff key
TK	SAE 1:8 taper , 22mm [7/8in] dia. x 35mm [1.38in] Extension, 3/8-24x19mm [.75in] internal thread
SM	11 tooth, 48mm [1.89in] extension, (modified length) 30mm [1.20in] effective spline
SH	13 tooth, 41mm [1.62in] length
HB	SAE 22mm [7/8in] dia. X 41mm [1.62in] Extension, 1/4in keyway and key, with speed sensor
HW	SAE 22mm [7/8in] dia. X 51mm [2.00in] Extension, 1/4in keyway and key, with speed sensor
HM	SAE 11 tooth spline, 48mm [1.89in] extension (modified length), with speed sensor
HH	SAE 13 tooth spline, 41mm [1.62in] length, with speed sensor
HK	SAE1:8 taper , 22mm [7/8in] dia. x 35mm [1.38in] extension and internal thread, with speed sensor
HY	SAE1:8 taper, 22mm [7/8in] dia. x 59mm [2.34in] extension and external thread and/key, with speed sensor

C - Mounting flange

A			B1	B2	C		D1	D2	E			F			G			J			K		
D	E	M				•	•																

Mounting flange

Code	Description
AA	SAE A, 2 bolt
BB	SAE B, 2 Bolt
AZ	SAE A, 2 bolt with speed sensor
BZ	SAE B, 2 bolt with speed sensor

D1 - Cover

A			B1	B2	C	D1	D2	E			F			G			J			K		
D	E	M				•																

Cover

Code	Description
N	No valves, standard cover
A	Cover with anti-cavitation check valve
B	Cover for use with low flow relief valve (P1, P3 or F) and anti-cavitation check valve
C	Cover for use with high flow relief valve (P2, P4 or G) and anti-cavitation check valve
P	Cover with empty SAE 12-2 cavity and anti-cavity (customer supplied) relief valve
S	Cover with empty SAE 10-2 cavity and anti-cavity (customer supplied) relief valve
R	Cover for reversing function with proportional relief, primary CW rotation
L	Cover for reversing function with proportional relief, primary CCW rotation

Product code
D2 - Rear cover port option

A			B1	B2	C	D1	D2			E			F			G			J	K			
D	E	M					•	•	•														

Rear cover port option

Code		Description	
Radial	Axial	Inlet/Outlet	Drain port
105*	505*	3/4-16 SAE O-ring boss	Radial 9/16-18 SAE (idler side**)
106*	506*	3/4-16 SAE O-ring boss	Radial 9/16-18 SAE (drive side**)
107	507	7/8-14 SAE O-ring boss	Radial 9/16-18 SAE (idler side**)
108	508	7/8-14 SAE O-ring boss	Radial 9/16-18 SAE (drive side**)
109	509	1 1/16-12 SAE O-ring boss	Radial 9/16-18 SAE (idler side**)
110	510	1 1/16-12 SAE O-ring boss	Radial 9/16-18 SAE (drive side**)
111	N/A	1 5/16-12 SAE O-ring boss	Radial 9/16-18 SAE (idler side**)
112	N/A	1 5/16-12 SAE O-ring boss	Radial 9/16-18 SAE (drive side**)
330	N/A	1 inch SAE Split flange	Radial 9/16-18 SAE (idler side**)
331	N/A	1 inch SAE Split flange	Radial 9/16-18 SAE (drive side**)
332	N/A	1-1/4 SAE Split flange	Radial 9/16-18 SAE (idler side**)
333	N/A	1-1/4 SAE Split flange	Radial 9/16-18 SAE (drive side**)

* Port Sizes available for 17cc displacement motors only

** See dimension drawings for explanation of drive and idler side.

D - Rear cover availability

A			B1	B2	C	D1	D2			E			F			G			J	K		
D	E	M				•	•	•	•													

Rear cover availability matrix

Code	D1 Rear cover/valve option ^{#5}							
D2 Port options	N	B	C	A	P	S	R	L
105	•	-	-	•	-	-	-	-
106	•	-	-	•	-	-	-	-
107	•	•	•	•	•	•	•	•
108	•	•	•	•	•	•	•	•
109	•	•	•	•	•	•	•	•
110	•	•	•	•	•	•	•	•
111	•	•	•	•	•	•	•	•
112	•	•	•	•	•	•	•	•
330/331	•	-	-	•	-	-	•	•
332/333	•	-	-	•	-	-	•	•
505	•	-	-	•	-	-	-	-
506	•	-	-	•	-	-	-	-

Product code

G Integrated reversing modulating function

Code	Description	Pressure bar [psi]	A [‡]	B [‡]	C [‡]	N [‡]	P [‡]	S [‡]	R [‡]	L [‡]
N000	No integrated reversing valve	N/A	•	•	•	•	•	•	-	-
A1AA	D03 Directional Valve P1 Style - Proportional relief valve 12 VDC	138 [2000]	-	-	-	-	-	-	•	•
A1AB		172 [2500]	-	-	-	-	-	-	•	•
A1AC		207 [3000]	-	-	-	-	-	-	•	•
A1AD		241 [3500]	-	-	-	-	-	-	•	•
A1AF		276 [4000]	-	-	-	-	-	-	•	•
A2AA	D03 Directional Valve P3 Style - Proportional relief valve 24 VDC	138 [2000]	-	-	-	-	-	-	•	•
A2AB		172 [2500]	-	-	-	-	-	-	•	•
A2AC		207 [3000]	-	-	-	-	-	-	•	•
A2AD		241 [3500]	-	-	-	-	-	-	•	•
A2AF		276 [4000]	-	-	-	-	-	-	•	•
B1AA	D05 Directional Valve P2 Style - Proportional relief valve 12 VDC	138 [2000]	-	-	-	-	-	-	•	•
B1AB		172 [2500]	-	-	-	-	-	-	•	•
B1AC		207 [3000]	-	-	-	-	-	-	•	•
B1AD		241 [3500]	-	-	-	-	-	-	•	•
B1AF		276 [4000]	-	-	-	-	-	-	•	•
B2AA	D05 Directional Valve P4 Style - Proportional relief valve 24 VDC	138 [2000]	-	-	-	-	-	-	•	•
B2AB		172 [2500]	-	-	-	-	-	-	•	•
B2AC		207 [3000]	-	-	-	-	-	-	•	•
B2AD		241 [3500]	-	-	-	-	-	-	•	•
B2AF		276 [4000]	-	-	-	-	-	-	•	•

‡ • Standard

§ - Not available

J - Name plate

A			B1	B2	C	D1	D2	E	F	G	J	K
D	E	M									•	•

Name plate

Code	Description
AN	Standard name plate

K - Name plate

A			B1	B2	C	D1	D2	E	F	G	J	K		
D	E	M										•	•	•

Product code

Name plate

Code	Description
NNN	No special features, standard black paint

Dimension drawings

Mounting flanges

SAE-A 2-bolt flange (AA)

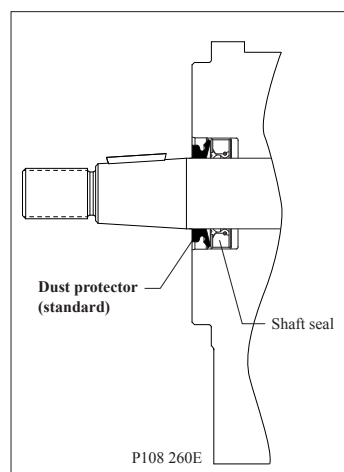
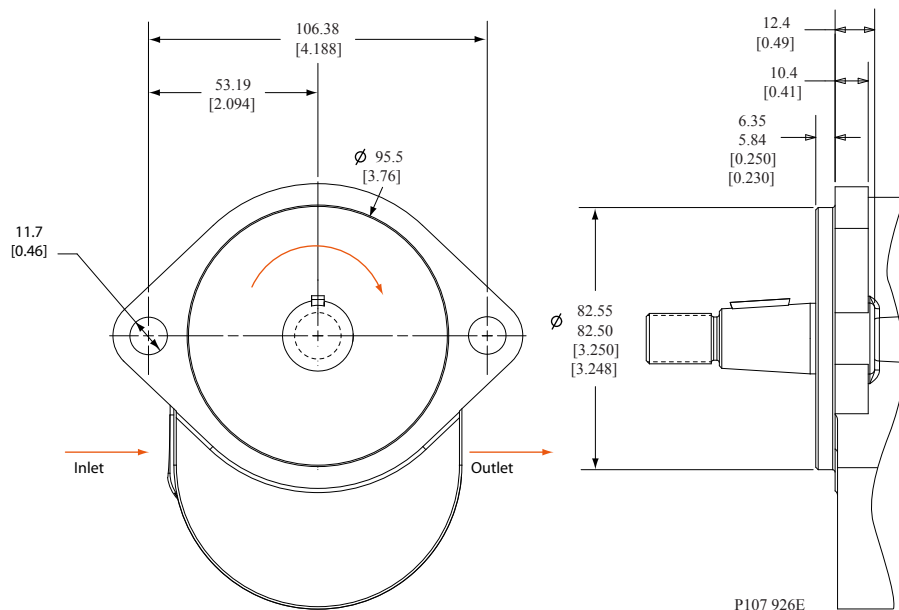

Dimension drawings

SAE-B 2-bolt flange (BB)

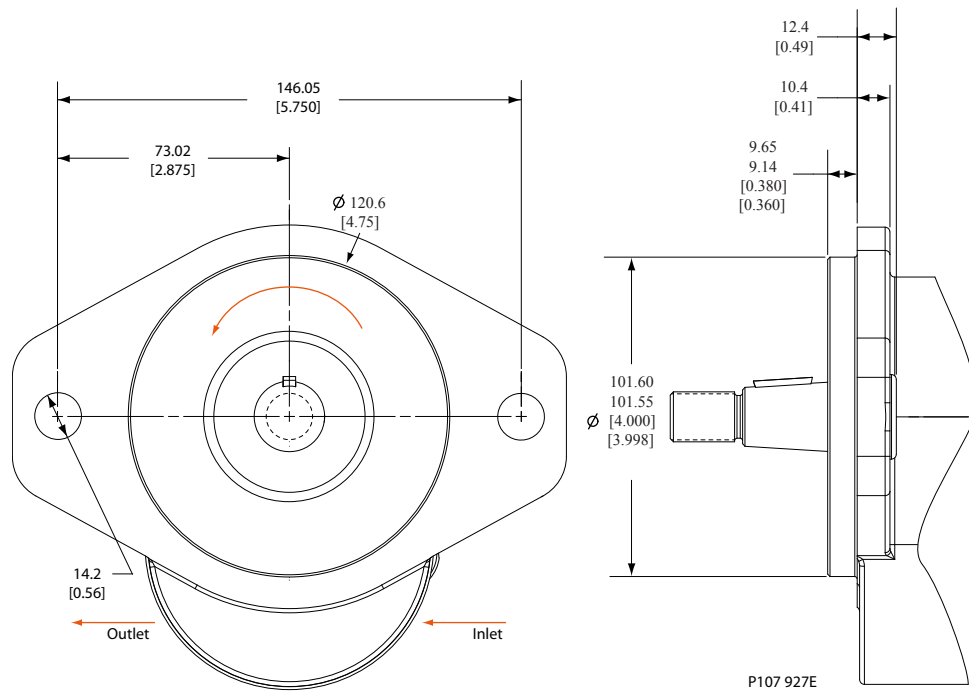

Shaft options

SM shaft option

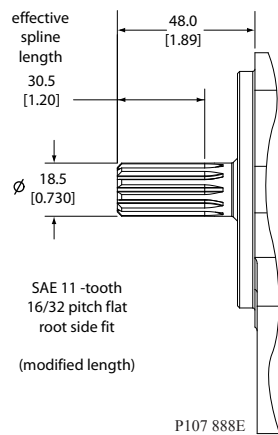

Dimension drawings

PB shaft option

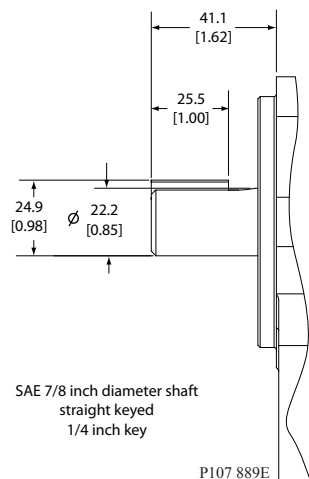

TY shaft option

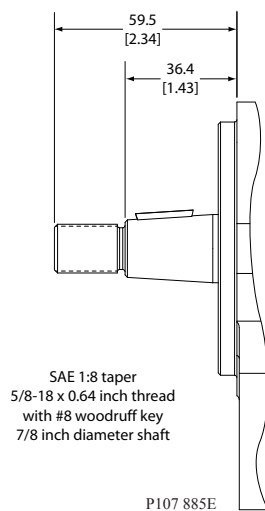

TK shaft option

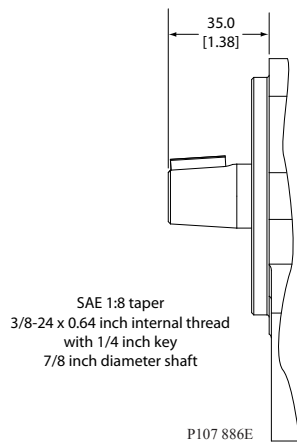

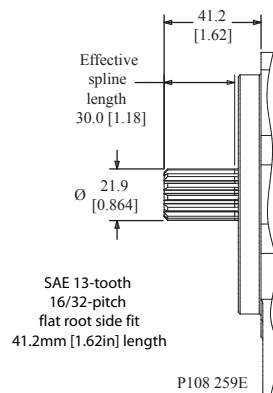
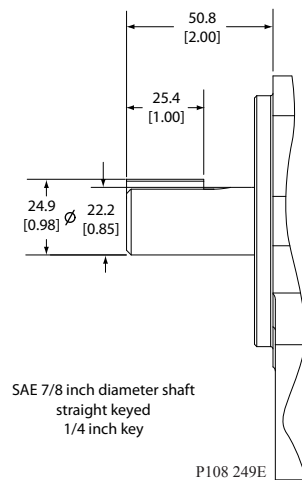
Dimension drawings
SH shaft option

PW shaft option

Shaft torque limits

Code	Type	Diameter mm [in]	Length mm [in]	Description	Allowable shaft torque N·m [lbf·in]
SM	Spline	19.1 [0.75]	38.1 [1.50]	SAE 11 tooth, 48mm [1.89in] extension, (modified length) 30mm [1.20in] effective spline	176.3 [1560]
PB	Straight key	22.2 [0.875]	41.2 [1.62]	SAE 2mm [7/8in] Ø x 41mm [1.62in] Extension, 1/4in key, with key	248.6 [2200]
TY	Tapered	22.2 [0.875]	49.6 [1.95]	SAE 1:8 taper, 22mm [7/8in] Ø x 59mm [2.34in] Extension, 5/8-18 x 21mm [.81in] external thread with #8 Woodruff key	225.9 [2000]
TK	Tapered	22.2 [0.875]	49.3 [1.94]	SAE 1:8 taper, 22mm [7/8in] Ø x 35mm [1.38in] Extension, 3/8-24 x 19mm [.75in] Internal thread	225.9 [2000]
SH	Spline	21.9 [0.864]	41.2 [1.62]	SAE 13 tooth, 41mm [1.62in] length	248.6 [2200]
PW	Straight key	22.2 [0.875]	50.8 [2.00]	SAE 22mm [7/8in] Ø x 51mm [2in] Extension, 1/4in key, with key	248.6 [2200]

Dimension drawings

Port options

SAE O-ring boss

Code		SAE O-ring boss ports - No valves		
Radial	Axial	Inlet	Outlet	Drain port
N105	N505	3/4-16 SAE	3/4-16 SAE	Radial 9/16-18 SAE (on idler side)
N106	N506	3/4-16 SAE	3/4-16 SAE	Radial 9/16-18 SAE (on drive side)
N107	N507	7/8-14 SAE	7/8-14 SAE	Radial 9/16-18 SAE (on idler side)
N108	N508	7/8-14 SAE	7/8-14 SAE	Radial 9/16-18 SAE (on drive side)
N109	N509	1 1/16-12 SAE	1 1/16-12 SAE	Radial 9/16-18 SAE (on idler side)
N110	N510	1 1/16-12 SAE	1 1/16-12 SAE	Radial 9/16-18 SAE (on drive side)
N111	N/A	1 5/16-12 SAE	1 5/16-12 SAE	Radial 9/16-18 SAE (on idler side)
N112	N/A	1 5/16-12 SAE	1 5/16-12 SAE	Radial 9/16-18 SAE (on drive side)

Port locations (SAE O-ring port shown)

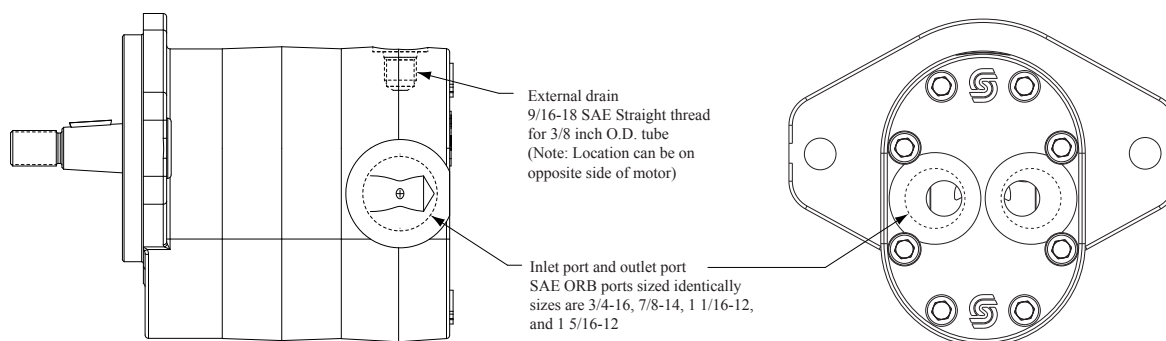

P107 904E

SAE Split flange ports

Code		SAE Split flange ports - No valves		
Radial		Inlet	Outlet	Drain port
N330		1 inch Split flange	1 inch Split flange	Radial 9/16-18 SAE (on idler side)
N331		1 inch Split flange	1 inch Split flange	Radial 9/16-18 SAE (on drive side)
N332		1-1/4 inch Split flange	1-1/4 inch Split flange	Radial 9/16-18 SAE (on idler side)
N333		1-1/4 inch Split flange	1-1/4 inch Split flange	Radial 9/16-18 SAE (on drive side)

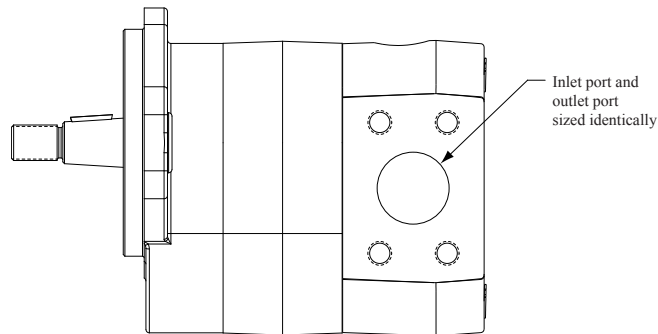
Dimension drawings
Split flange ports

P107 942E

Selecting port options

Use the following tables for selecting port options. Recommendations assume maximum rated speed. Applications running at lower speeds may use smaller port sizes. Contact your Danfoss representative.

Recommended port size by displacement

Displacement code	Recommended port size
17	1-1/16 inch
19	1-1/16 inch
21	1 - 5/16 inch
23	1 - 5/16 inch
25	1 - 5/16 inch
29	1 - 5/16 inch
32	1 - 5/16 inch
36	1 - 5/16 inch
38	1 - 5/16 inch
41	1 - 5/16 inch
45	1 inch split flange

Maximum flow by port size

Port size	Maximum flow l/min [US gal/min]
3/4 -16 SAE ORB	26 [7]
7/8-14 SAE ORB	41 [11]
1 1/16-12 SAE ORB	68 [18]
1 5/16-12 SAE ORB	132 [35]
1 inch Split flange	216 [57]
1 1/4 inch Split flange	288 [76]

Dimension drawings
Integrated reversing motor with proportional relief and shock/anti-cavitation valves

The D Series Motor can be configured to include an integrated reversing option for high performance fan drive systems requiring variable speed and reversal of fan direction to purge coolers and radiators.

Features and benefits

- Solenoid reversing valve directs flow to either side of the motor to reverse fan rotation. The valve uses an open transition spool to reduce the likelihood of pressure spikes during sudden reversals and is available in two flow ranges to minimize losses.
- Integrated proportional pressure control to modulate fan speed by modulating pressure across the fan motor. The valve is available in two flow ranges and is normally closed to ensure full fan speed in case of loss of electrical signal.
- Dual shock valves limit pressure spikes in both forward and reverse rotation and eliminates damage to the system during sudden fan reversals.
- Dual anti-cavitation check valves bypass motor flow during fan deceleration.
- The motor is PLUS+1™ compliant allowing the user to take advantage of automatic cleaning sequences available on Danfoss microcontrollers.
- Valves are qualified to 276 bar (4000 psi) and are contained in a steel body to ensure maximum performance and long life at elevated temperatures and pressures.
- Deutsch connectors, Viton® seals and shaft dust protector are standard for operation in severe environments.
- Integrated valve design provides short length and high power density in a compact package while minimizing installation costs.

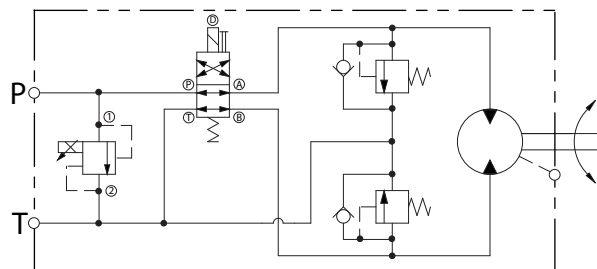

P108 250E

Technical data

The directional control valve uses an internal spring to bias spool position and direct flow to the motor. As a result, the preferred motor rotation must be specified in the model code. A right hand motor would be biased for clockwise rotation with counter-clockwise reversing, while a left hand motor would be biased for counter-clockwise rotation with clockwise reversing.

Dimension drawings

The reversing valve function is available in two flow ratings. The D05 directional valve is standard with the high flow proportional valve, while the D03 directional valve is standard with the low flow proportional valve. Use the P-T pressure drop curves to minimize pressure drop at maximum flow conditions.

Integrated reversing function

Select the size and voltage of the reversing valve option using the codes and P-T pressure drop curves below. The pressure settings and performance curves for the proportional relief valve can be found on the following pages.

Code	Description
A1	D03 Directional valve with P1 (low flow) style proportional relief valve, 12VDC
A2	D03 Directional valve with P3 (low flow) style proportional relief valve, 24VDC
B1	D05 Directional valve with P2 (high flow) style proportional relief valve, 12VDC
B2	D05 Directional valve with P4 (high flow) style proportional relief valve, 24VDC

Pressure loss measured with Mobile DTE 24 at 105°F [41°C]

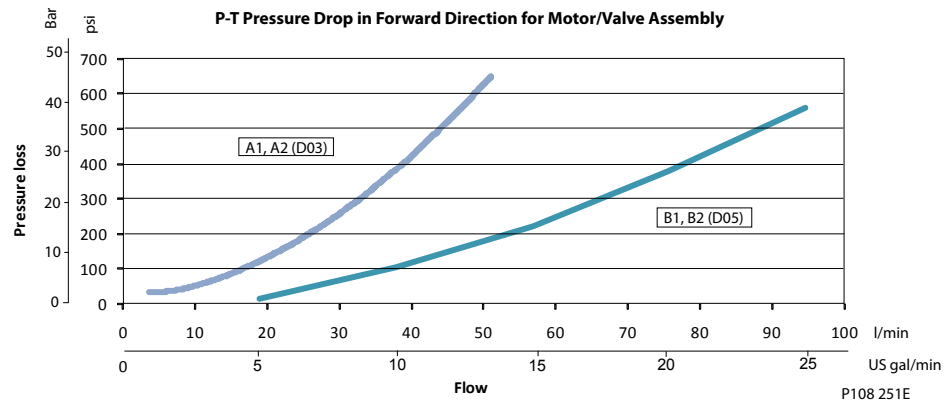

Includes pressure drop across D03/D05 in default position as well as losses across unloaded gear motor

Options

Standard relief valve

The fixed-setting pressure relief valve limits maximum fan speed and protects the motor from over-pressurization.

Mount the motor so the relief valve is below the reservoir oil level. Keep the relief valve in a horizontal position. Be sure to bleed the system to remove entrained air.

Code	Description
F	Relief valve internally drained - applications with 95 l/min [26 US gal/min] or less flow
G	Relief valve internally drained - applications with 96-190 l/min [26-50 US gal/min] flow

Any modification to the valve to change the factory setting will void product warranty.

The fixed-setting relief valve can only be used to limit fan speed in one rotational direction. As a result, the preferred motor rotation must be specified in the model code - DEML or DEMR.

Schematic: Motor with standard relief valve with optional anti-cavitation valve

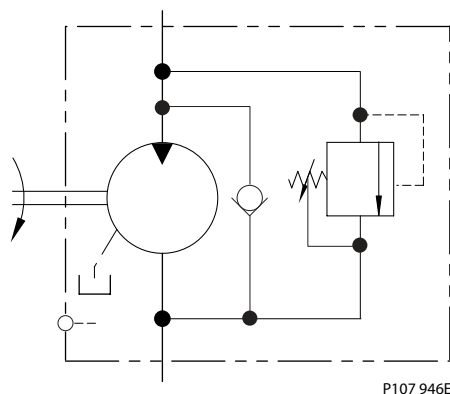

Standard relief valve

Anti-cavitation check valve

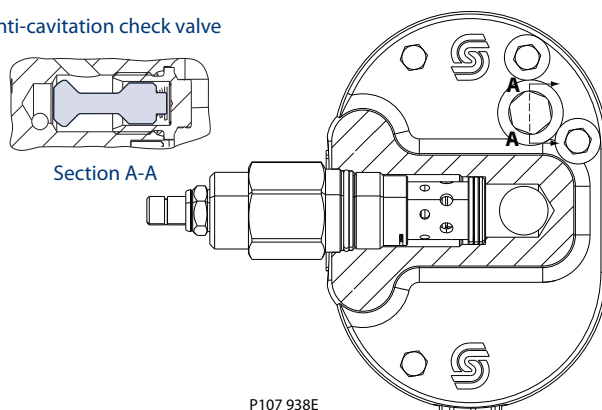

Relief pressure vs flow at $T_{oil}=51.7^{\circ}\text{C}$ [125°F], viscosity = 30 mm²/sec (cSt) [141 SUS] set at 19 l/min [5 US gal/min]

F Valve settings

Valve option	Pressure setting bar [psi]
276	276 [4000]
241	241 [3500]
207	207 [3000]

Options

F Valve settings (continued)

Valve option	Pressure setting bar [psi]
172	172 [2500]
138	138 [2000]

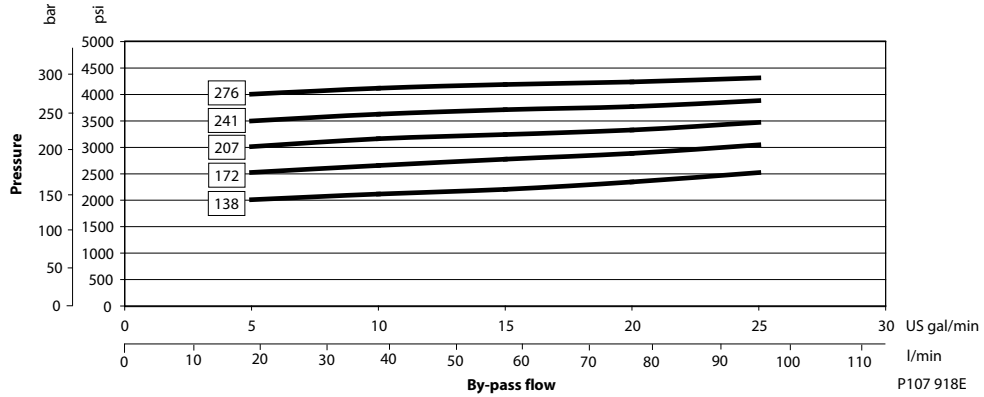

G valve settings

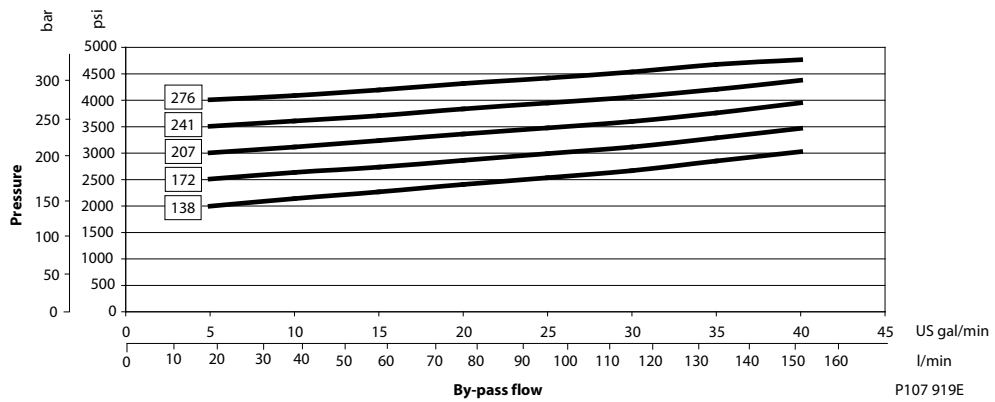

Anti-cavitation check valve

D motors are available with an optional anti-cavitation check valve. The valve is integrated into the rear cover. The anti-cavitation check valve protects the motor from cavitation in overrunning conditions.

Standard rear cover with anti-cavitation valve

Anti-cavitation check valve

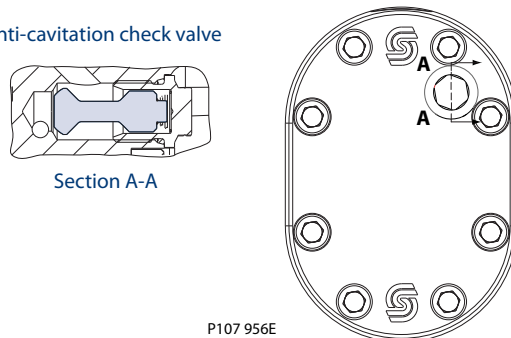

P107 956E

Options

Schematic: Motor with anti-cavitation check valve

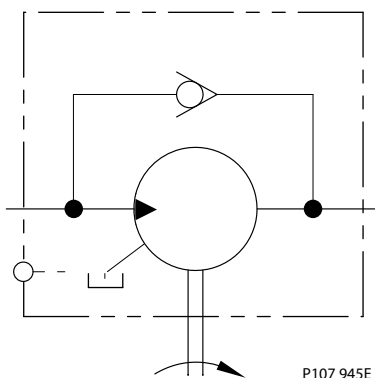

Proportional relief valve with anti-cavitation valve

The D Series motor may be equipped with a normally closed proportional relief valve, which modulates the fan speed for on demand cooling in fan drive applications. This valve can also trim maximum fan speed at a pre-set pressure. Mount the motor so the relief valve is below the reservoir oil level. Keep the relief valve in a horizontal position. Be sure to bleed the system to remove entrained air.

Relief valve cutaway

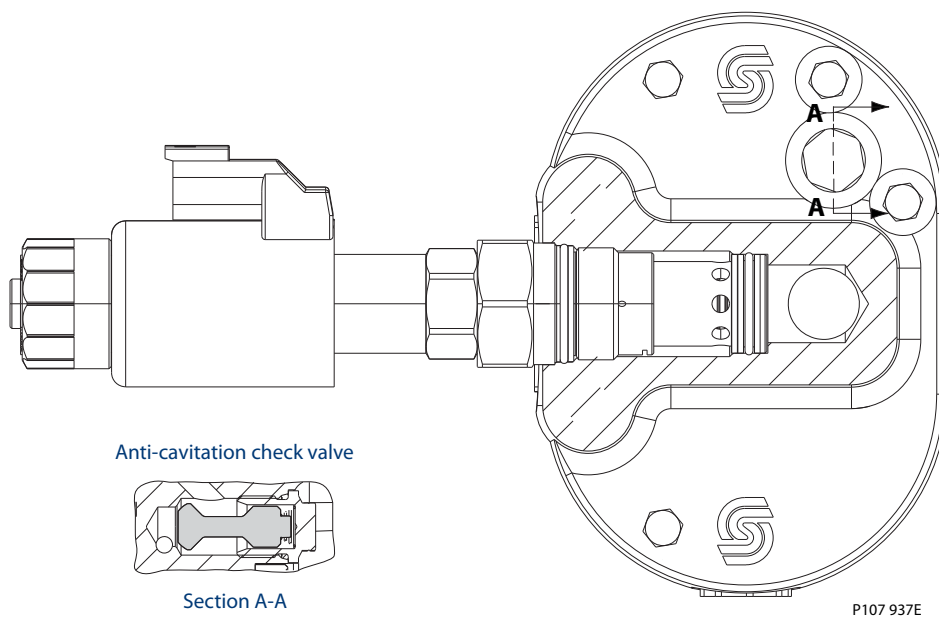

Technical data

Capacity	95 l/min [25 US gal/min] or 96-190 l/min [25-50 US gal/min]
Electrical connector	DEUTSCH® DT-04-2P (protection rate IP 69K DIN 40050)

Options

Technical data (continued)

Electrical supply	0 -1.1 A at 12 Vdc with	Coil resistance of 6.4 Ohms at 20° C [68° F]
		Minimum voltage 10.8 Vdc
	0 -0.55 A at 24 Vdc with	Coil resistance of 26.2 Ohms at 20° C [68° F]
		Minimum voltage 21.6 Vdc
PWM frequency	100 - 250 Hz	

The proportional relief valve can only be used to modulate fan speed in one rotational direction. As a result, the preferred motor rotation must be specified in the model code - DEML or DEMR.

Schematic: Motor with proportional relief valve and anti-cavitation check valve

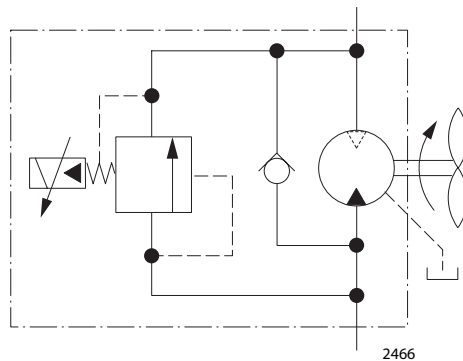

Valve settings

Code	Description
P1	12 Vdc Proportional relief valve internally drained, low flow
P2	12 Vdc Proportional relief valve internally drained, high flow
P3	24 Vdc Proportional relief valve internally drained, low flow
P4	24 Vdc Proportional relief valve internally drained, high flow

Select proportional relief valve setting using the pressure vs. bypass flow graphs. Any modification to the valve to change the factory setting will void product warranty.

P1 and P3 valve settings (low flow)

Valve option	Pressure setting bar [psi]
AF	276 [4000]
AD	241 [3500]
AC	207 [3000]
AB	172 [2500]
AA	138 [2000]

Options

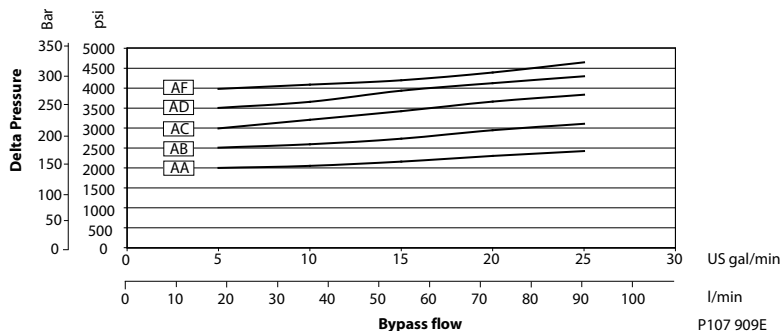

P2 and P4 valve settings (high flow)

Valve option	Pressure setting bar [psi]
BF	276 [4000]
BD	241 [3500]
BC	207 [3000]
BB	172 [2500]
BA	138 [2000]

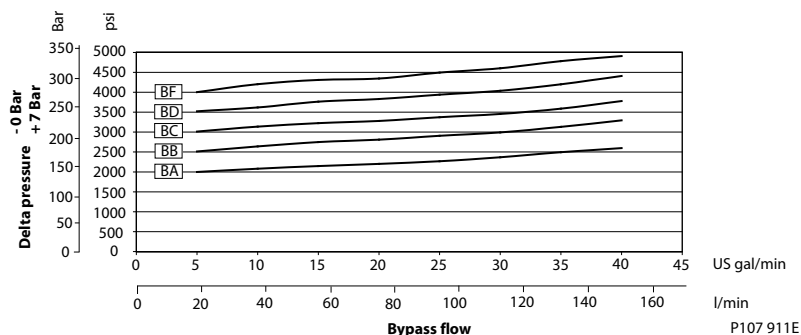

Performance graphs

Relief pressure vs flow at Toil=51.7°C [125°F], viscosity = 30 mm²/sec (cSt) [141 SUS] set at 19 l/min [5 US gal/min] and zero current

Pressure drop with coil energized, valve only

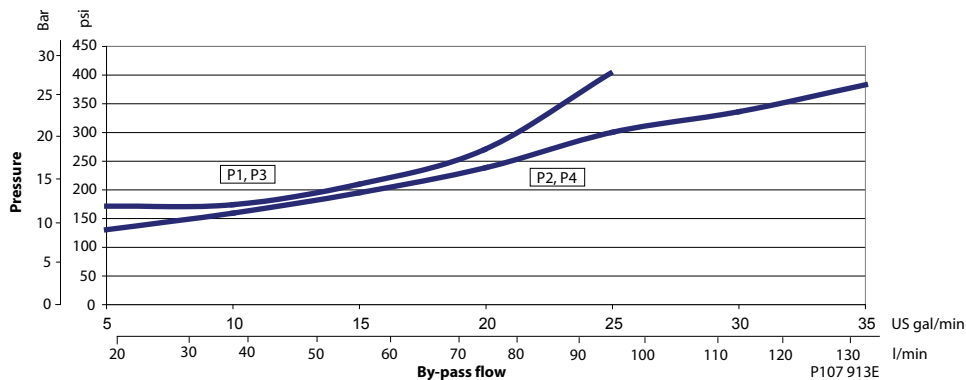

Options

Valve settings

Code	Description
P1	12 Vdc Proportional relief valve internally drained - with 95 l/min [25 US gal/min] or less flow
P2	12 Vdc Proportional relief valve internally drained - with 96-190 l/min[26-50 US gal/min] flow
P3	24 Vdc Proportional relief valve internally drained - with 95 l/min [25 US gal/min] or less flow
P4	24 Vdc Proportional relief valve internally drained - with 96-190 l/min[26-50 US gal/min] flow

Any modification to the valve to change the factory setting will void product warranty.

Performance graphs

Relief pressure vs flow at Toil=51.7°C [125°F], viscosity = 30 mm²/sec (cSt) [141 SUS] set at 19 l/min [5 US gal/min] and zero current

P1, Relief pressure vs. current

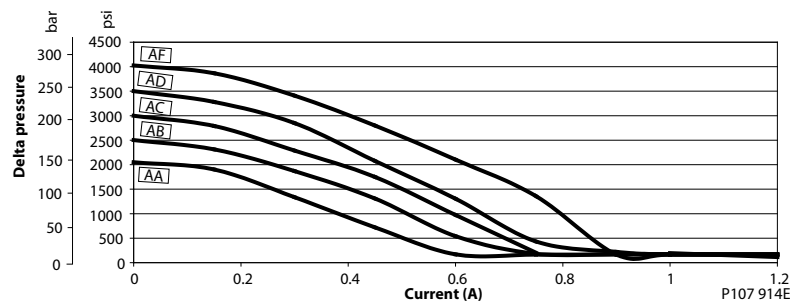

P2, Relief pressure vs. current

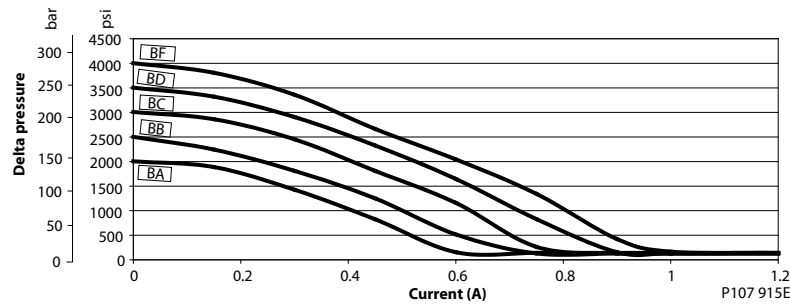

P3, Relief pressure vs. current

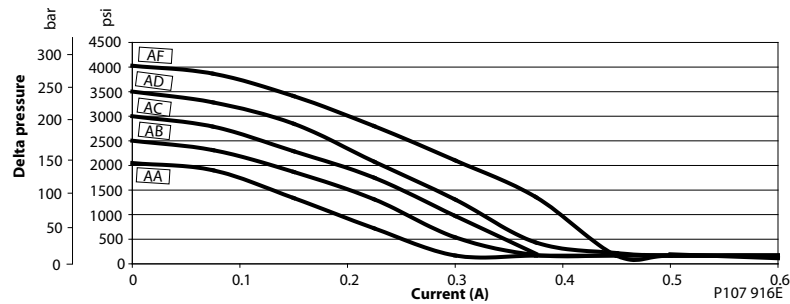

Options

P4, Relief pressure vs. current

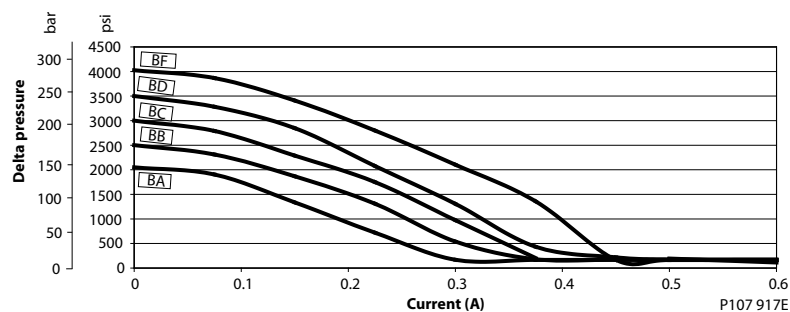

Hall effect speed sensor

Dimensions mm [in]

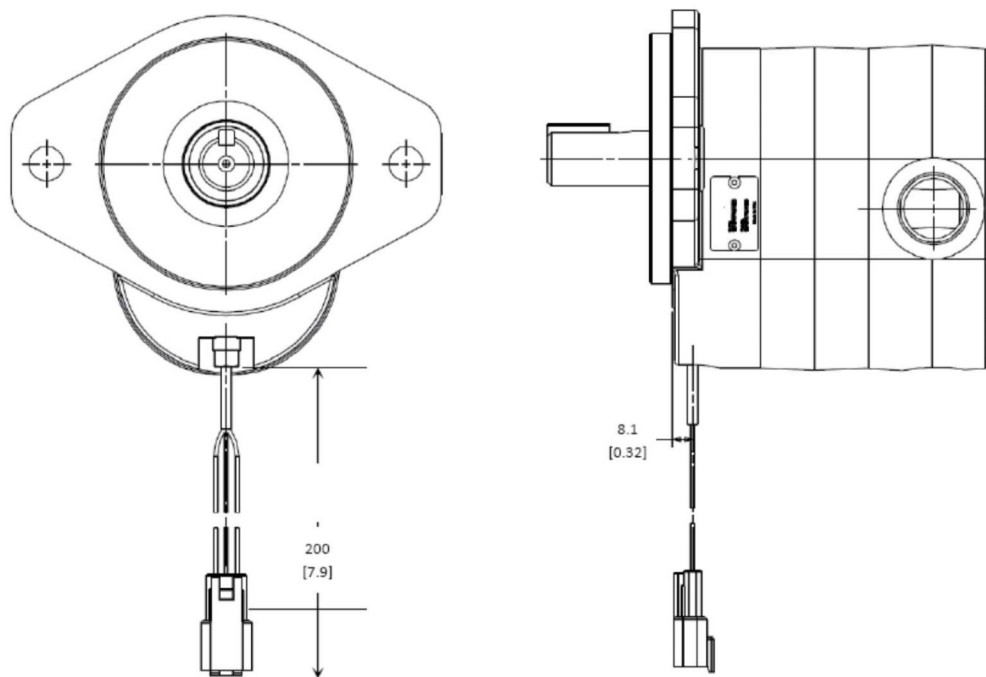

Connector	DEUTSCH® DTM04-3P 3-Pin, Female
Output signal	0 - 5 V, NPN @ ≤ 25mA Sink
Supply voltage	5 - 30 VDC @ ≤ 18mA
Frequency range	8 pulses per revolution 425 Hz at maximum motor speed (3400 rpm)
Protection level	IP67

Options

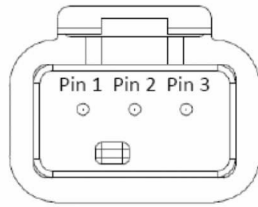

As viewed looking into the connector

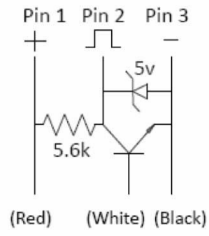

Dimension drawings

Fan drive motor

Fan drive motor example

Fan drive motor:

Right hand rotation, 17 cm³, 1:8 taper shaft, SAE A two bolt mounting, 7/8-14 ports, idler side drain, P1 style proportional relief valve at 172 bar, anti-cavitation valve.

D motor dimensions; SAE-B two bolt fan drive motor shown

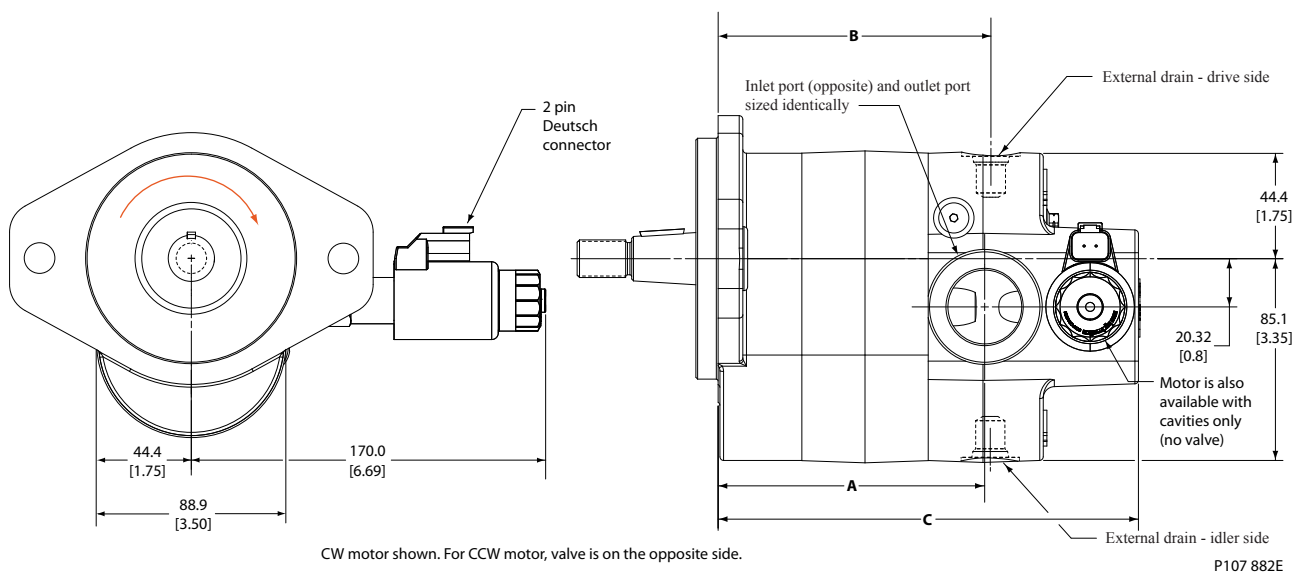

Dimensions (maximum)

Dimension	Units	17	19	21	23	25	29	32	36	38	41	45
A	mm	88.9	90.9	92.5	94.2	97.3	100.8	103.6	107.7	109.7	112.8	117.1
	in	3.50	3.58	3.64	3.71	3.83	3.97	4.08	4.24	4.32	4.44	4.61
B	mm	91.7	93.8	95.3	97.0	100.1	103.6	106.4	110.7	112.5	115.6	119.9
	in	3.61	3.69	3.75	3.82	3.94	4.08	4.19	4.36	4.43	4.55	4.72
C	mm	154.4	156.5	158.0	160.0	162.8	166.4	169.2	173.5	175.5	178.6	182.6
	in	6.08	6.18	6.22	6.30	6.41	6.55	6.66	6.83	6.91	7.03	7.19

Standard motor

Standard motor example

Bi-rotational, 17 cm³, 1:8 taper shaft, SAE B two bolt mounting, 7/8-14 ports, idler side drain, no relief valve.

Dimension drawings

Standard D Series motor dimensions, SAE-B two bolt motor shown

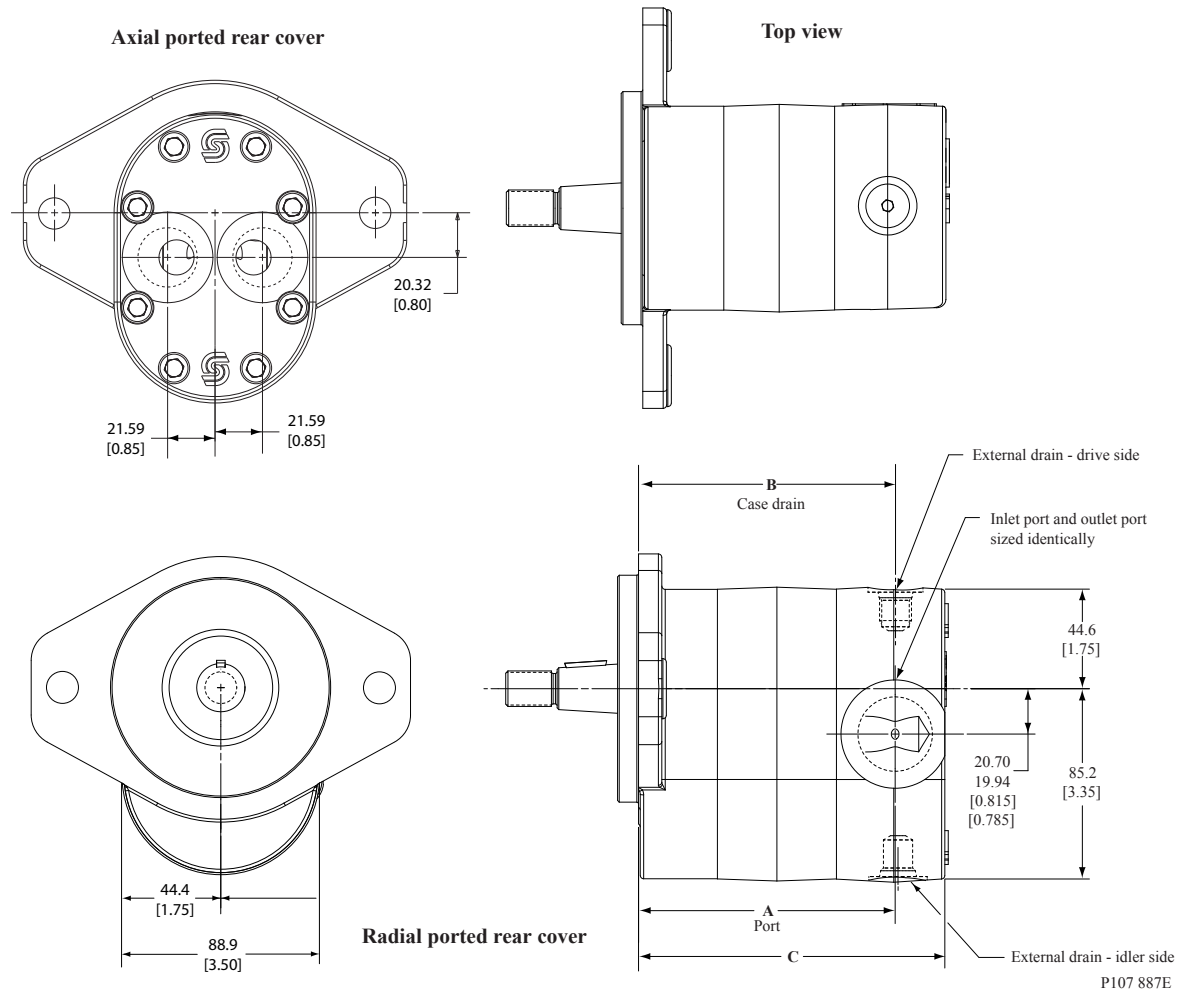

Dimensions (maximum)

Dimension	Units	17	19	21	23	25	29	32	36	38	41	45
A	mm	90.7	92.7	94.3	96.1	99.1	102.7	105.4	109.7	111.7	114.7	118.9
	in	3.57	3.65	3.71	3.78	3.9	4.04	4.15	4.32	4.4	4.51	4.68
B	mm	90.9	92.9	94.4	96.3	99.3	102.8	105.6	109.9	111.8	114.8	119.1
	in	3.58	3.66	3.72	3.79	3.91	4.05	4.16	4.33	4.4	4.52	4.69
C	mm	112.9	115.0	116.5	118.3	121.3	124.9	127.7	131.9	133.9	136.9	141.1
	in	4.45	4.53	4.59	4.66	4.78	4.92	5.03	5.19	5.27	5.39	5.56

Standard motor with split flange ports

Standard motor with split flange ports example

Bi-rotational, 17 cm³, SAE 1:8 taper shaft, SAE B two bolt mounting, Split flange ports, drive side drain, No valve.

Dimension drawings

Standard D Series motor dimensions, SAE-B two bolt motor shown with split flange ports

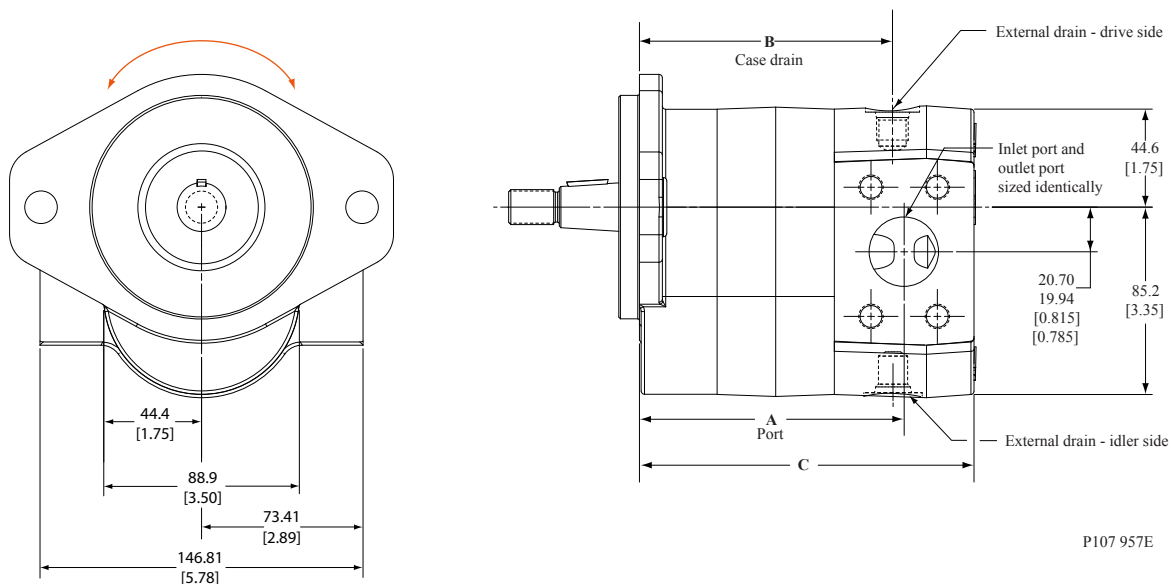

P107 957E

Dimensions (maximum)

Dimension	Units	17	19	21	23	25	29	32	36	38	41	45
A	mm	96.8	98.8	100.3	102.1	105.2	108.7	111.5	115.8	117.6	120.6	125.0
	in	3.81	3.89	3.95	4.02	4.14	4.28	4.39	4.56	4.63	4.75	4.92
B	mm	91.7	93.8	95.3	97.0	100.1	103.6	106.4	110.7	112.5	115.6	119.9
	in	3.61	3.69	3.75	3.82	3.94	4.08	4.19	4.36	4.43	4.55	4.72
C	mm	128.8	130.8	132.3	134.4	137.2	140.7	143.5	147.8	149.9	152.9	157.0
	in	5.07	5.15	5.21	5.29	5.40	5.54	5.65	5.82	5.90	6.02	6.18

Dimension drawings

Integrated reversing motor with proportional relief and shock/anti-cavitation valves

Reversing fan drive motor with D03 directions valve, clockwise rotation

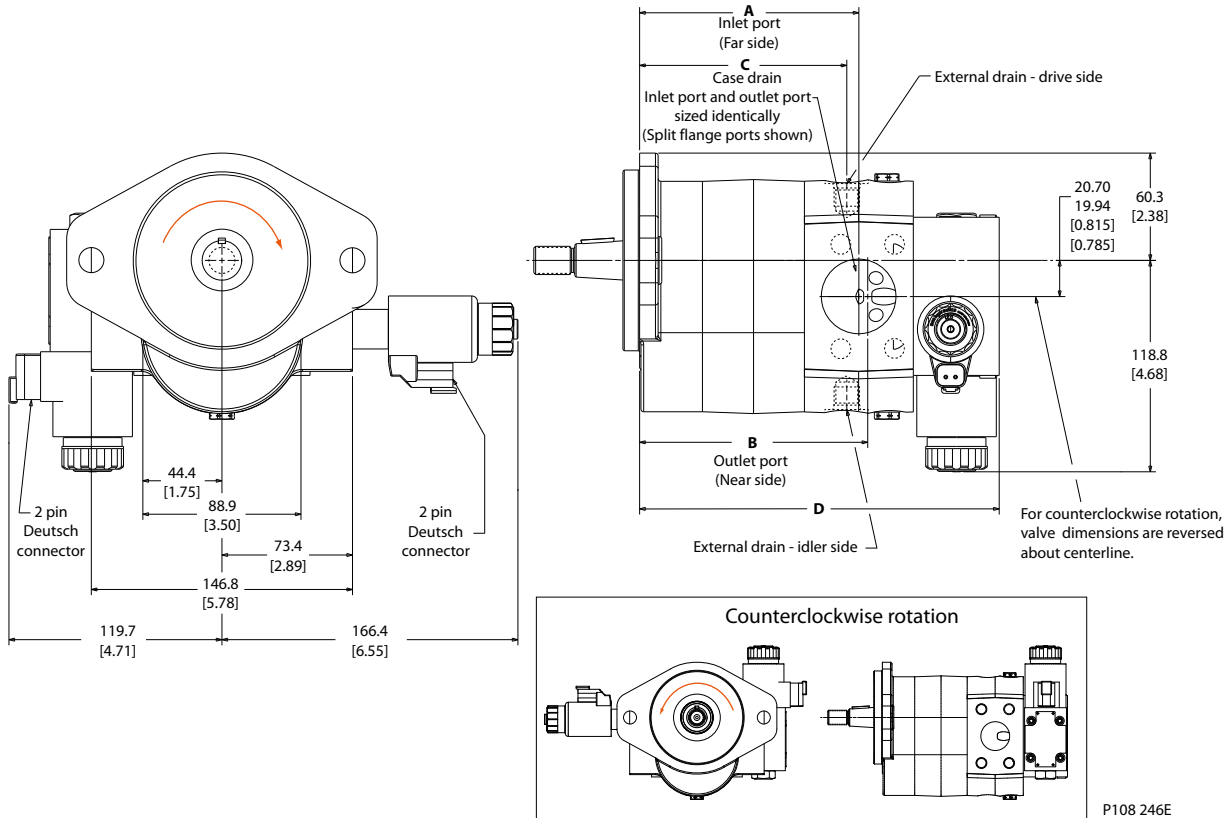

P108 246E

Dimensions (maximum)

Dimensions	Port	Units	17	19	21	23	25	29	32	36	38	41	45
A	All	mm	95.0	97.1	98.6	100.4	103.4	107.0	109.8	114.0	116.0	119.0	123.2
		in	3.74	3.82	3.88	3.95	4.07	4.21	4.32	4.49	4.57	4.69	4.85
B	107-108	mm	103.3	105.3	106.9	108.7	111.7	115.3	118.0	122.3	124.3	127.3	131.5
		in	4.07	4.15	4.21	4.28	4.40	4.54	4.65	4.82	4.89	5.01	5.18
	109-110	mm	101.1	103.1	104.7	106.5	109.5	113.1	115.8	120.1	122.1	125.1	129.3
		in	3.98	4.06	4.12	4.19	4.31	4.45	4.56	4.73	4.81	4.93	5.09
	111-112	mm	97.7	99.8	101.3	103.1	106.1	109.7	112.5	116.8	118.7	121.7	125.9
		in	3.85	3.93	3.99	4.06	4.18	4.32	4.43	4.60	4.67	4.79	4.96
	330-331	mm	100.6	102.7	104.2	106.0	109.0	112.6	115.4	119.6	121.6	124.6	128.8
		in	3.96	4.04	4.10	4.18	4.29	4.43	4.54	4.71	4.79	4.91	5.07
332-333	mm	100.0	102.1	103.6	105.4	108.4	112.0	114.8	119.0	121.0	124.0	128.2	
	in	3.94	4.02	4.08	4.15	4.27	4.41	4.52	4.69	4.76	4.88	5.05	
C	All	mm	88.2	90.3	91.8	93.6	96.6	100.2	103.0	107.3	109.2	112.2	116.4
		in	3.47	3.55	3.61	3.69	3.80	3.95	4.05	4.22	4.30	4.42	4.58
D	All	mm	174.4	176.5	178.0	179.8	182.8	186.4	189.2	193.4	195.4	198.4	202.6
		in	6.87	6.95	7.01	7.08	7.20	7.34	7.45	7.62	7.69	7.81	7.98

Dimension drawings

Reversing fan drive motor with D05 directional valve, clockwise rotation

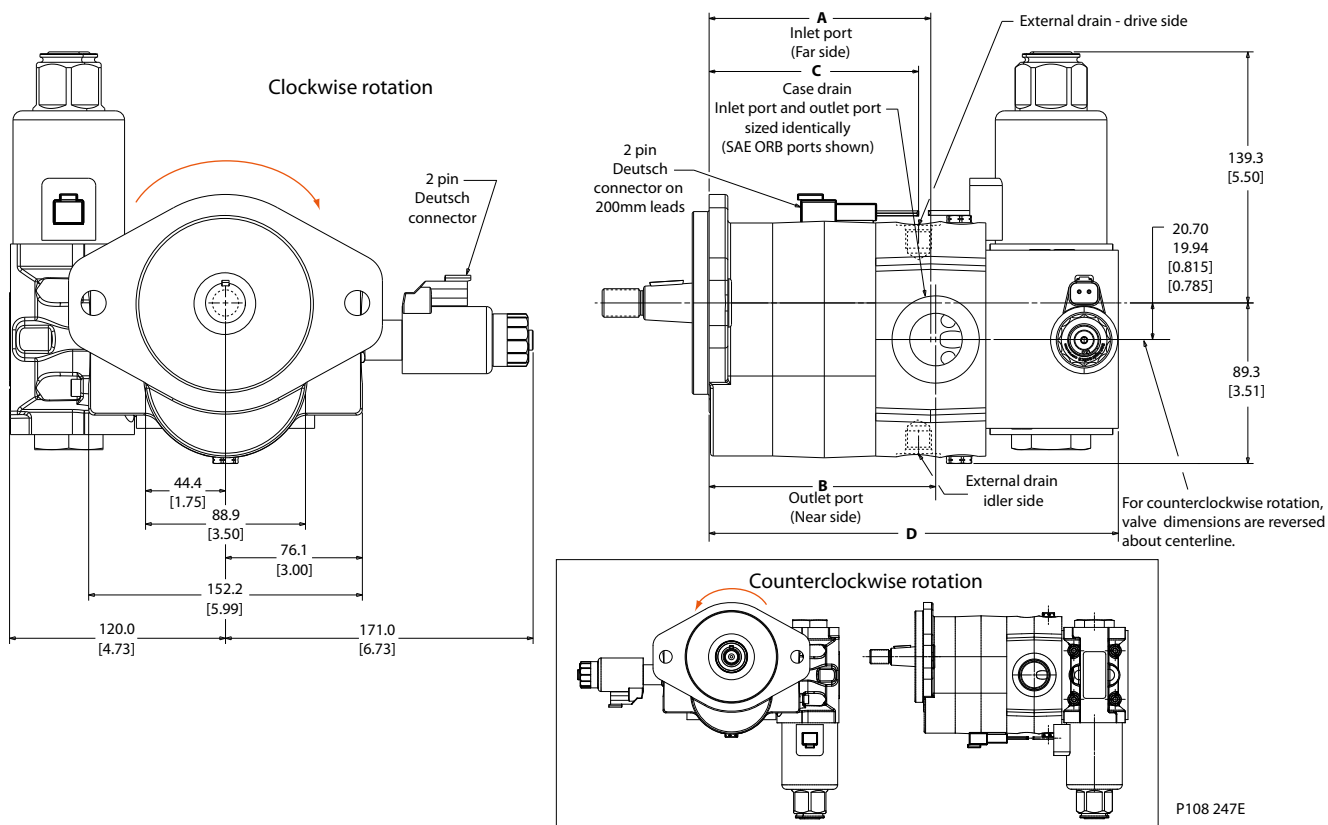

Dimensions (maximum)

Dimensions	Port	Units	17	19	21	23	25	29	32	36	38	41	45	
A	All	mm	95.0	97.1	98.6	100.4	103.4	107.0	109.8	114.0	116.0	119.0	123.2	
		in	3.74	3.82	3.88	3.95	4.07	4.21	4.32	4.49	4.57	4.69	4.85	
B	107-108	mm	103.3	105.3	106.9	108.7	111.7	115.3	118.0	122.3	124.3	127.3	131.5	
		in	4.07	4.15	4.21	4.28	4.40	4.54	4.65	4.82	4.89	5.01	5.18	
	109-110	mm	101.1	103.1	104.7	106.5	109.5	113.1	115.8	120.1	122.1	125.1	129.3	
		in	3.98	4.06	4.12	4.19	4.31	4.45	4.56	4.73	4.81	4.93	5.09	
	111-112	mm	97.7	99.8	101.3	103.1	106.1	109.7	112.5	116.8	118.7	121.7	125.9	
		in	3.85	3.93	3.99	4.06	4.18	4.32	4.43	4.60	4.67	4.79	4.96	
	330-331	mm	100.6	102.7	104.2	106.0	109.0	112.6	115.4	119.6	121.6	124.6	128.8	
		in	3.96	4.04	4.10	4.18	4.29	4.43	4.54	4.71	4.79	4.91	5.07	
	332-333	mm	100.0	102.1	103.6	105.4	108.4	112.0	114.8	119.0	121.0	124.0	128.2	
		in	3.94	4.02	4.08	4.15	4.27	4.41	4.52	4.69	4.76	4.88	5.05	
	C	All	mm	88.2	90.3	91.8	93.6	96.6	100.2	103.0	107.3	109.2	112.2	116.4
			in	3.47	3.55	3.61	3.69	3.80	3.95	4.05	4.22	4.30	4.42	4.58
D	All	mm	199.8	201.9	203.4	205.2	208.2	211.8	214.6	218.8	220.8	223.8	228.0	
		in	7.87	7.95	8.01	8.08	8.20	8.34	8.45	8.62	8.69	8.81	8.98	

Performance data

Motor performance graphs

The graphs show typical inlet flow and output power for the D series motors at various working pressures as a function of speed. Data were taken using hydraulic fluid conforming to ISO VG46 at 50°C [120° F] with viscosity at 28 mm²/sec (cSt) [132 SUS].

17.6 cm³ [1.07 in³]

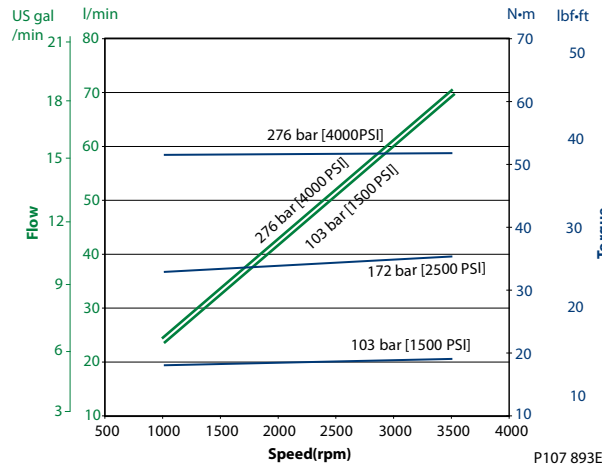

19.9 cm³ [1.21 in³]

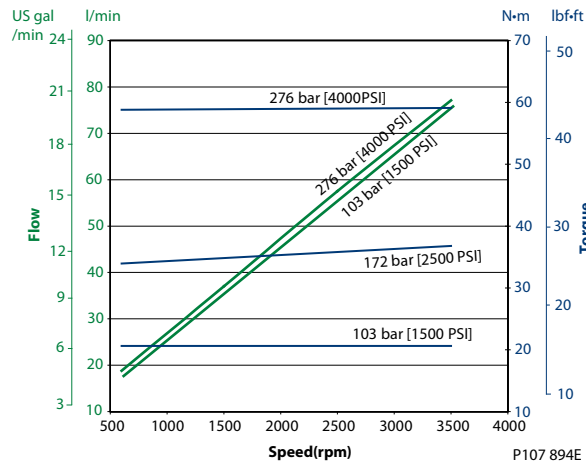

Performance data

$22.4 \text{ cm}^3 [1.37 \text{ in}^3]$

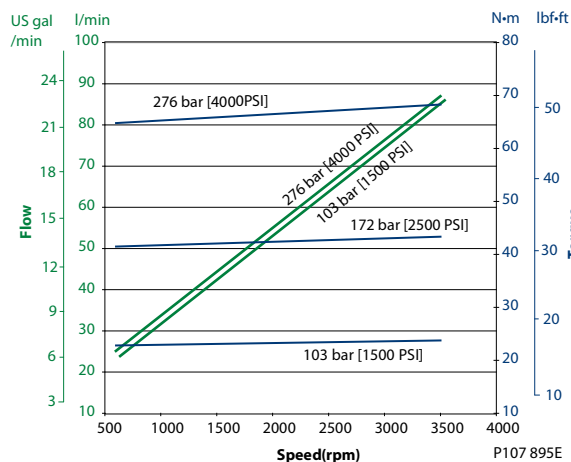

$23.2 \text{ cm}^3 [1.42 \text{ in}^3]$

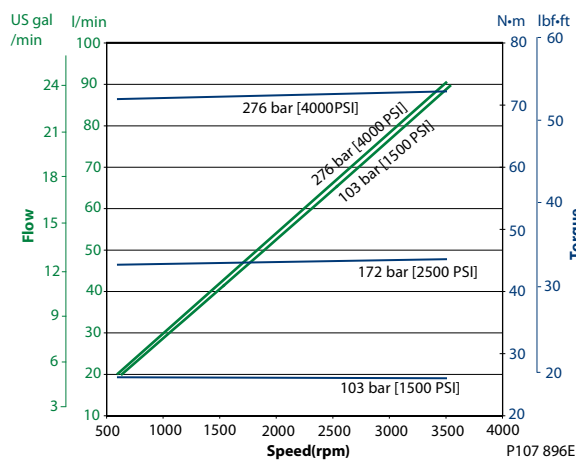

$26.2 \text{ cm}^3 [1.60 \text{ in}^3]$

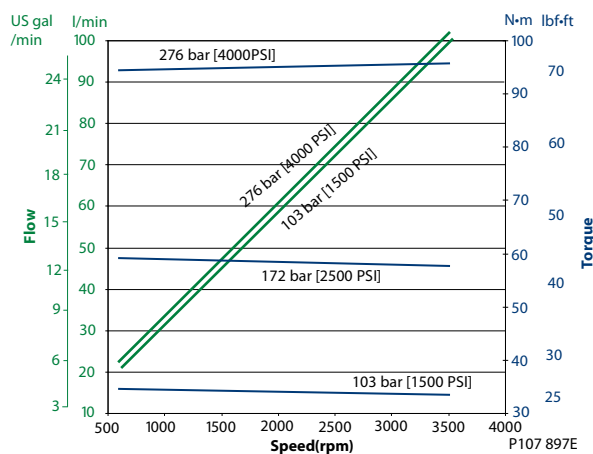

Performance data

$30.6 \text{ cm}^3 [1.87 \text{ in}^3]$

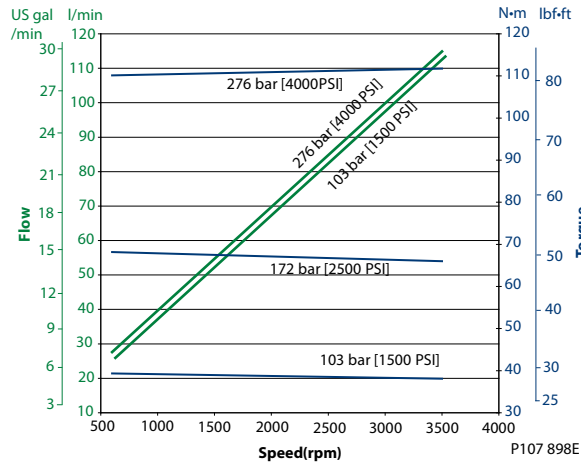

$34.4 \text{ cm}^3 [2.10 \text{ in}^3]$

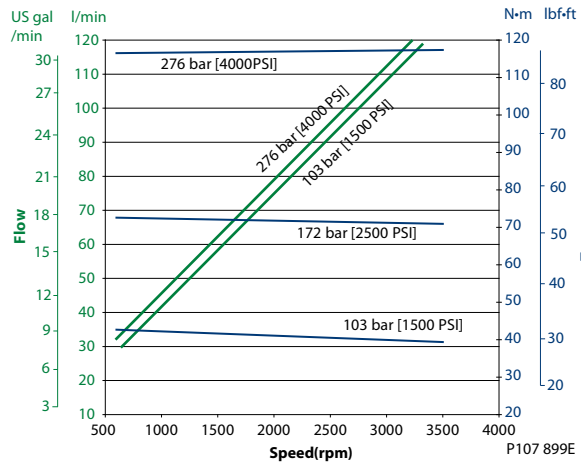

$38.6 \text{ cm}^3 [2.36 \text{ in}^3]$

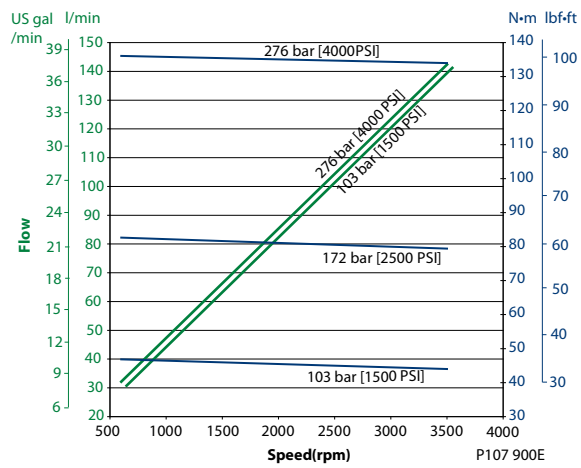

Performance data

40.9 cm³ [2.50 in³]

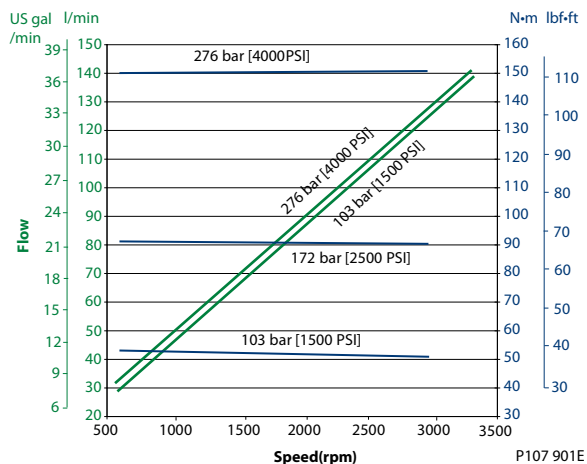

42.9 cm³ [2.62 in³]

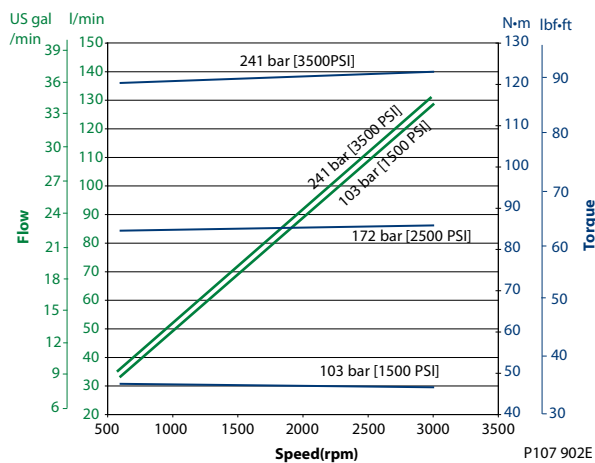

48.3 cm³ [2.95 in³]

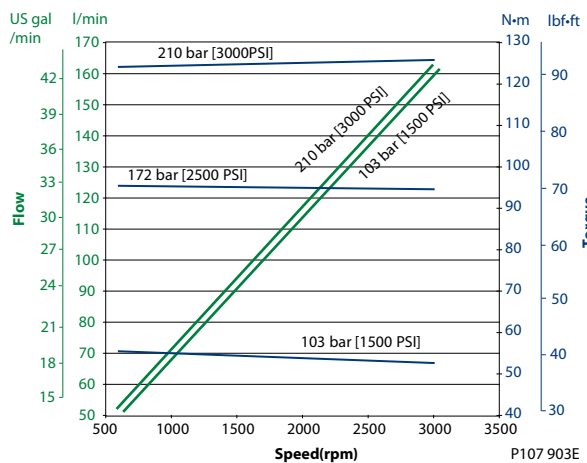



Products we offer:

- Cartridge valves
- DCV directional control valves
- Electric converters
- Electric machines
- Electric motors
- Gear motors
- Gear pumps
- Hydraulic integrated circuits (HICs)
- Hydrostatic motors
- Hydrostatic pumps
- Orbital motors
- PLUS+1® controllers
- PLUS+1® displays
- PLUS+1® joysticks and pedals
- PLUS+1® operator interfaces
- PLUS+1® sensors
- PLUS+1® software
- PLUS+1® software services, support and training
- Position controls and sensors
- PVG proportional valves
- Steering components and systems
- Telematics

Danfoss Power Solutions is a global manufacturer and supplier of high-quality hydraulic and electric components. We specialize in providing state-of-the-art technology and solutions that excel in the harsh operating conditions of the mobile off-highway market as well as the marine sector. Building on our extensive applications expertise, we work closely with you to ensure exceptional performance for a broad range of applications. We help you and other customers around the world speed up system development, reduce costs and bring vehicles and vessels to market faster.

Danfoss Power Solutions – your strongest partner in mobile hydraulics and mobile electrification.

Go to www.danfoss.com for further product information.

We offer you expert worldwide support for ensuring the best possible solutions for outstanding performance. And with an extensive network of Global Service Partners, we also provide you with comprehensive global service for all of our components.

Hydro-Gear

www.hydro-gear.com

Daikin-Sauer-Danfoss

www.daikin-sauer-danfoss.com

Local address:



BIBUS SK, s.r.o
Trnavská 31, SK-94 901 Nitra

Tel.: 037/ 7777 911 Email: sale@bibus.sk
Fax.: 037/ 7777 999 <http://www.bibus.sk>

Danfoss Power Solutions (US) Company
2800 East 13th Street
Ames, IA 50010, USA
Phone: +1 515 239 6000

Danfoss Power Solutions GmbH & Co. OHG
Krokamp 35
D-24539 Neumünster, Germany
Phone: +49 4321 871 0

Danfoss Power Solutions ApS
Nordborgvej 81
DK-6430 Nordborg, Denmark
Phone: +45 7488 2222

Danfoss Power Solutions Trading (Shanghai) Co., Ltd.
Building #22, No. 1000 Jin Hai Rd
Jin Qiao, Pudong New District
Shanghai, China 201206
Phone: +86 21 2080 6201

Danfoss can accept no responsibility for possible errors in catalogues, brochures and other printed material. Danfoss reserves the right to alter its products without notice. This also applies to products already on order provided that such alterations can be made without subsequent changes being necessary in specifications already agreed. All trademarks in this material are property of the respective companies. Danfoss and the Danfoss logotype are trademarks of Danfoss A/S. All rights reserved.